

THIS DRAWING IS UNPUBLISHED. RELEASED FOR PUBLICATION 20
 © COPYRIGHT 20 BY TYCO ELECTRONICS CORPORATION. ALL RIGHTS RESERVED.

LOC	DIST	REVISIONS					
GP	00	P	LTR	DESCRIPTION	DATE	DWN	APVD
		A		RELEASED	24JUL2006	RG	SF

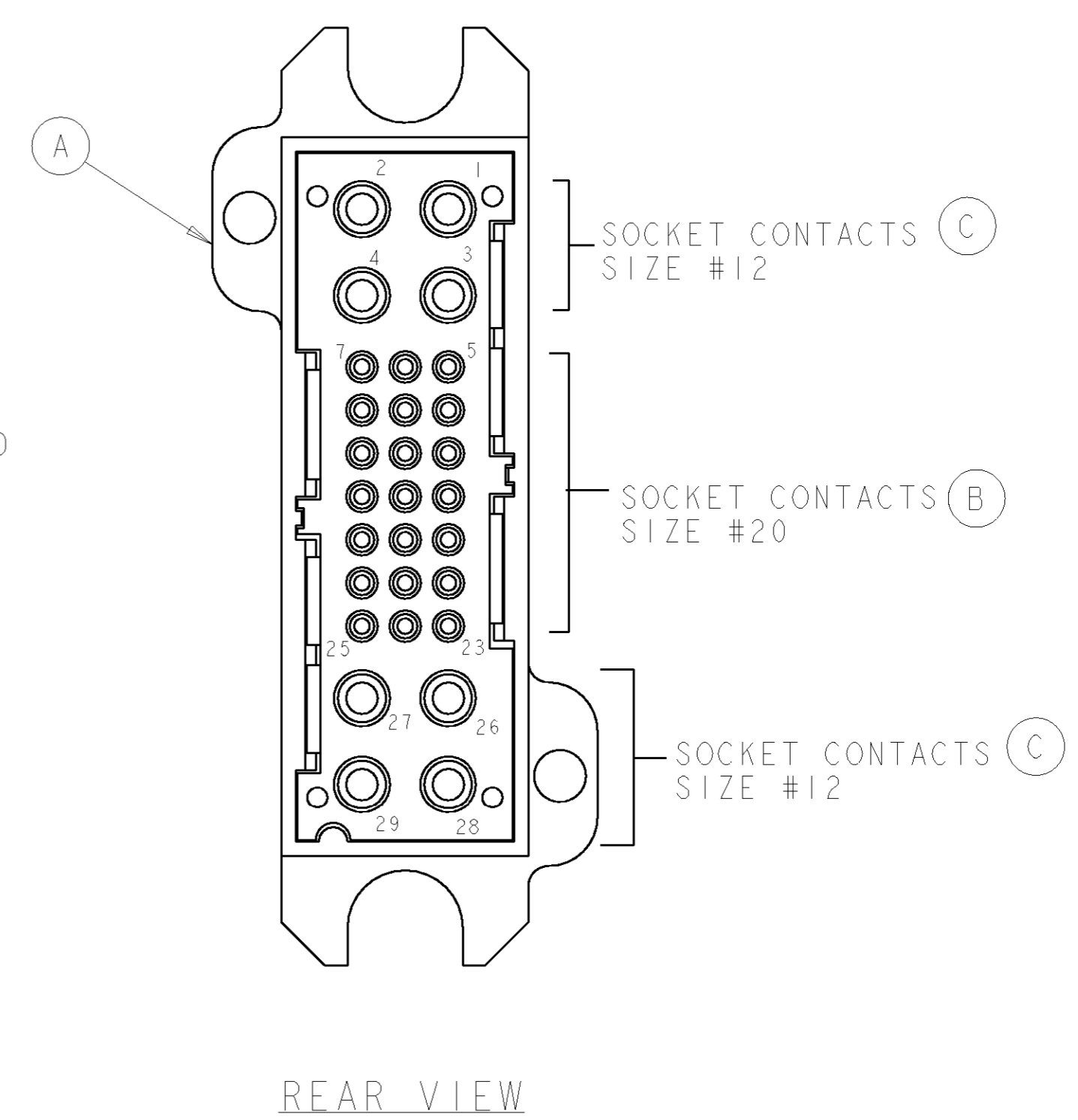
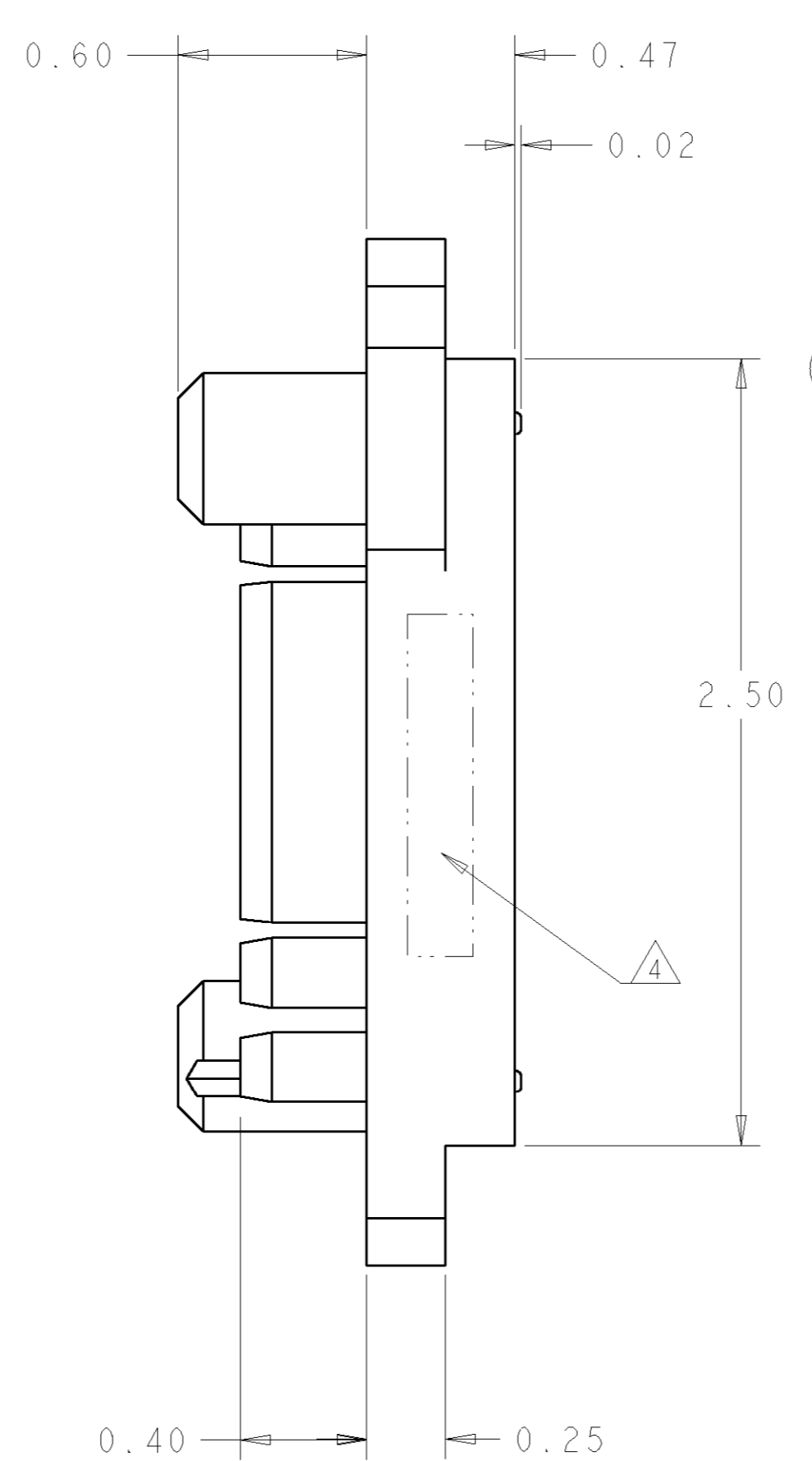
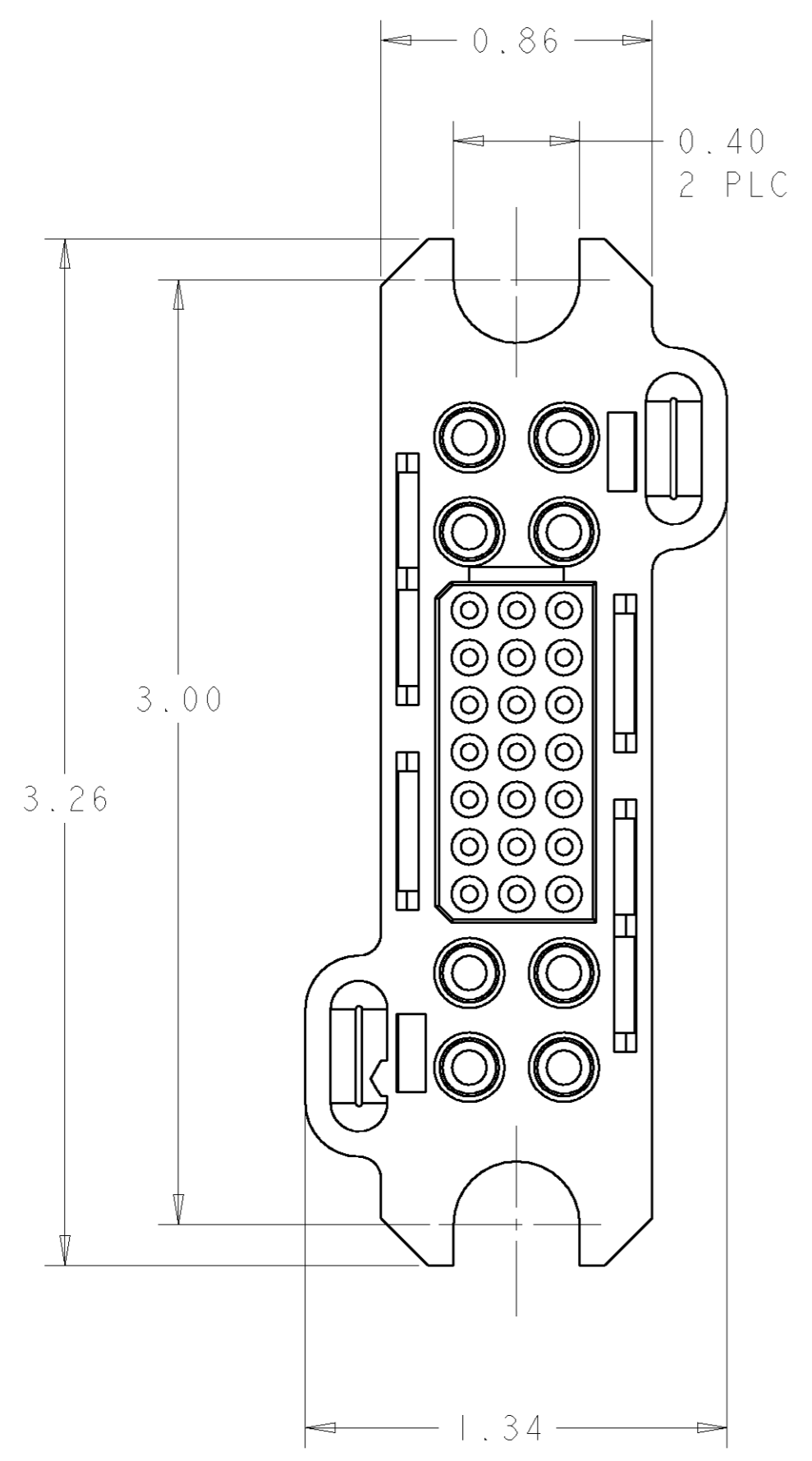

AS SHOWN	1926160-1
DESCRIPTION	PART NUMBER

THIS DRAWING IS A CONTROLLED DOCUMENT FOR TYCO ELECTRONICS CORPORATION IT IS SUBJECT TO CHANGE AND THE CONTROLLING ENGINEERING ORGANIZATION SHOULD BE CONTACTED FOR THE LATEST REVISION.		DWN R. GRZYBOWSKI 15 JUN 06 CHK S. FLICKINGER 15 JUN 06 APVD S. FLICKINGER 15 JUN 06	tyco Electronics Tyco Electronics Harrisburg, PA 17105-3608
DIMENSIONS: INCHES 	TOLERANCES UNLESS OTHERWISE SPECIFIED: 0 PLC ± 1 PLC ± 2 PLC ±.02 3 PLC ±.010 4 PLC ± ANGLES ±.5 FINISH	PRODUCT SPEC APPLICATION SPEC WEIGHT CUSTOMER DRAWING	NAME CONNECTOR ASSEMBLY SOCKET 75 AMP, LOWER DRAWER SIZE CAGE CODE DRAWING NO RESTRICTED TO A200779 C-1926160 - SCALE 3:1 SHEET 1 OF 2 REV A

ELCON LOWER DRAWER

