

## General Description

The AH9279 is a most advanced fan control and drive Hall IC manufactured by special CMOS process. This IC consists of voltage reference, Hall sensor, signal amplifier, wave shaping circuit, locked rotor detector, locked rotor protection and restart circuit, output drive circuit, etc.. To allow survival in a harsh environment and in consideration of low cost, the AH9279 has been designed with many functions internally, and requires less external components.

When there is no motion for one second, the IC will detect locked rotor conditions, enter protection mode automatically and disable two outputs for five seconds. Then, it will turn on drive current from one channel for one second. If it still fails to detect fan rotation, the AH9279 will shut off the outputs for five seconds again. This sequence will be repeated until rotation condition is detected and the IC enters normal operation mode. This function prevents the chip from overheating and damage due to long time locked rotor.

The power dissipation decides allowable maximum ambient temperature. Low power dissipation of AH9279 and the output MOSFET power transistor enable it to be used at ambient temperature up to 125°C on condition that the drive power is lower than 100mW or drive current is less than 200mA.

The AH9279 is available in TO-94 package.

## Features

- On Chip Hall Sensor
- Built-in Zener Diodes Protection for Output Driver
- Power Efficient CMOS and Power MOSFET Drivers Allow 400mA Without Overheating
- 5V and 12V Operation
- High Sensitivity for Switching Symmetry
- Locked Rotor Shutdown and Auto Restart
- ESD Rating: 4000V(Human Body Model)  
400V(Machine Model)

## Applications

- Dual-coil Brushless DC Fan



Figure 1. Package Type of AH9279

## Pin Configuration

Z4 Package  
(TO-94)

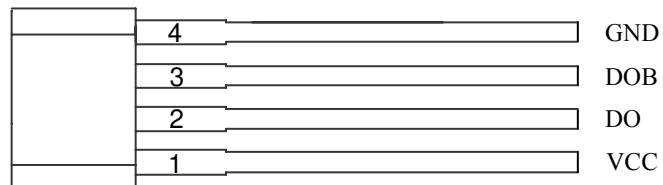

Figure 2. Pin Configuration of AH9279 (Front View)

## Pin Description

Pin Number	Pin Name	Function
1	VCC	Power supply pin
2	DO	Output pin 1
3	DOB	Output pin 2
4	GND	Ground pin

### Functional Block Diagram

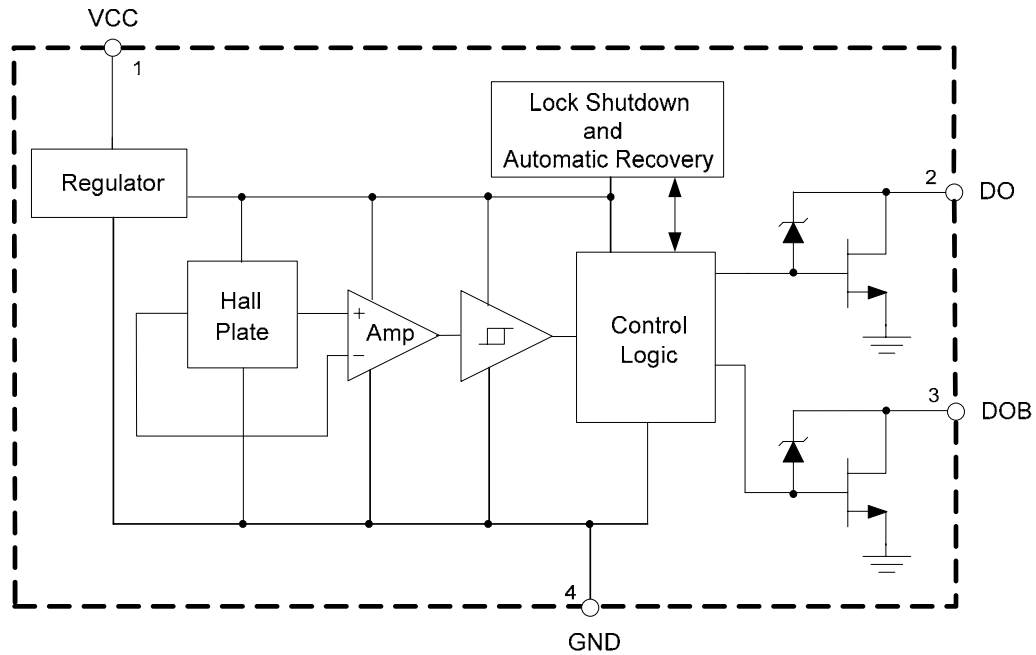
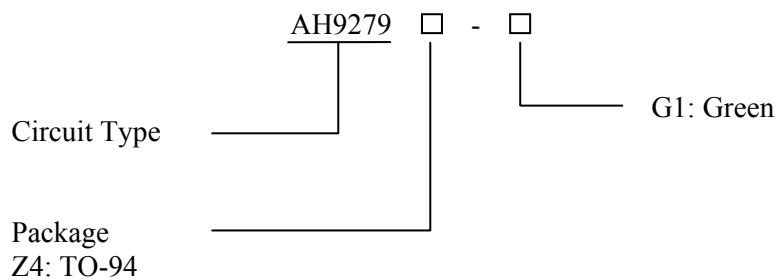

Figure 3. Functional Block Diagram of AH9279

### Ordering Information



Package	Temperature Range	Part Number	Marking ID	Packing Type
TO-94	-20 to 125°C	AH9279Z4-G1	9279Z4-G1	Bulk

BCD Semiconductor's Pb-free products, as designated with "G1" suffix in the part number, are RoHS compliant and green.

**TWO PHASE DUAL-COIL CMOS SMART FAN MOTOR DRIVER****AH9279****Absolute Maximum Ratings (T<sub>A</sub>=25°C, Note 1)**

Parameter	Symbol	Value	Unit
Supply Voltage	V <sub>CC</sub>	18	V
Supply current (Fault)	I <sub>CC</sub>	5	mA
Output current	I <sub>OUT</sub>	500	mA
Power dissipation	P <sub>D</sub>	550	mW
Thermal Resistance (Junction to Ambient)	θ <sub>JA</sub>	227	°C/W
Storage Temperature	T <sub>STG</sub>	-55 to 150	°C
ESD (Human Body Model)	ESD	4000	V
ESD (Machine Model)	ESD	400	V

Note 1: Stresses greater than those listed under “Absolute Maximum Ratings” may cause permanent damage to the device. These are stress ratings only, and functional operation of the device at these or any other conditions beyond those indicated under “Recommended Operating Conditions” is not implied. Exposure to “Absolute Maximum Ratings” for extended periods may affect device reliability.

**Recommended Operating Conditions**

Parameter	Symbol	Min	Max	Unit
Supply Voltage	V <sub>CC</sub>	3.5	16	V
Ambient Temperature	T <sub>A</sub>	-20	125	°C

**TWO PHASE DUAL-COIL CMOS SMART FAN MOTOR DRIVER**
**AH9279**

## Electrical Characteristics

 $V_{CC}=12V$ ,  $T_A=25^{\circ}C$ , unless otherwise specified.

Parameter	Symbol	Conditions	Min	Typ	Max	Unit
Supply Voltage	$V_{CC}$	Operating	3.5		16	V
Supply Current	$I_{CC}$	Average		3.5	5	mA
Output Current	$I_{OUT}$				500	mA
Output Leakage Current	$I_{LEAKAGE}$	$V_{OUT}=24V$		0.1	10	$\mu A$
Saturation Voltage	$V_{SAT}$	$I_{OUT}=350mA$		600	1000	mV
Output ON Time	$t_{ON}$			0.8		S
Output OFF Time	$t_{OFF}$			5		S
Output Zener Break-down Voltage	$V_Z$			35		V
Thermal Resistance (Junction to Case)	$\theta_{JC}$			49		$^{\circ}C/W$

## Magnetic Characteristics

 $V_{CC}=12V$ ,  $T_A=25^{\circ}C$ , unless otherwise specified.

Parameter	Symbol	Min	Typ	Max	Unit
Operating Point	$B_{OP}$		25	50	Gauss
Releasing Point	$B_{RP}$	-50	-25		Gauss
Hysteresis	$B_{HYS}$		50		Gauss

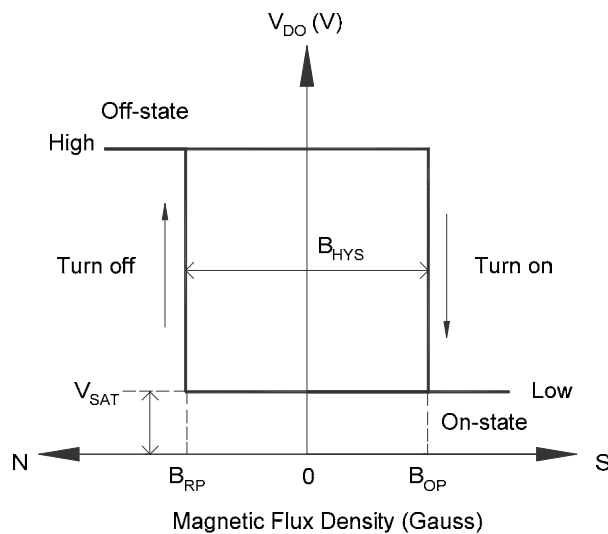

**Test Circuit**

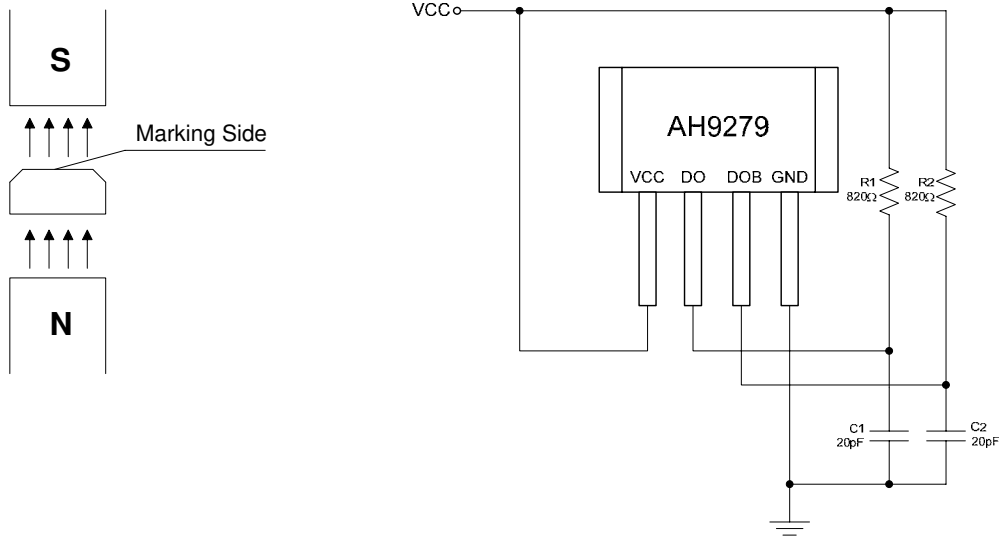

Figure 4. Basic Test Circuit of AH9279

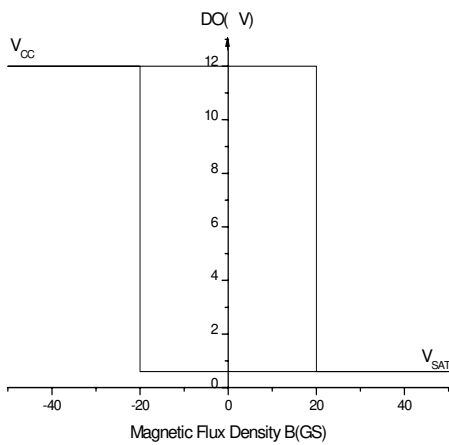

Figure 5.  $V_{DO}$  vs. Magnetic Flux Density

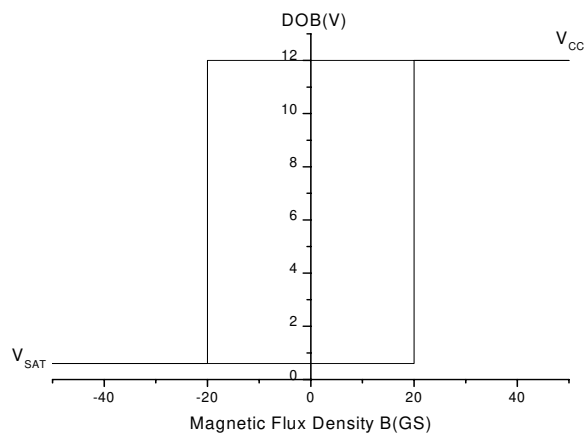

Figure 6.  $V_{DOB}$  vs. Magnetic Flux Density

**Typical Performance Characteristics**

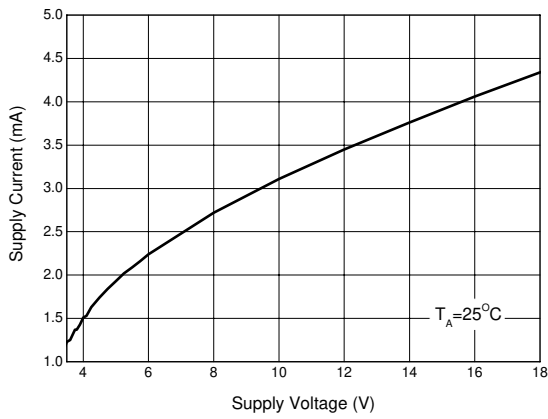

Figure 7. Supply Current vs. Supply Voltage

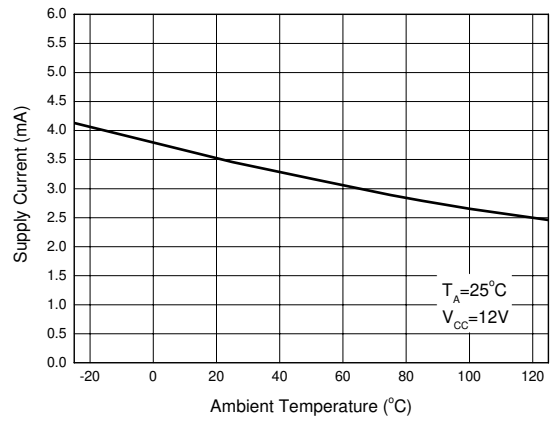

Figure 8. Supply Current vs. Ambient Temperature

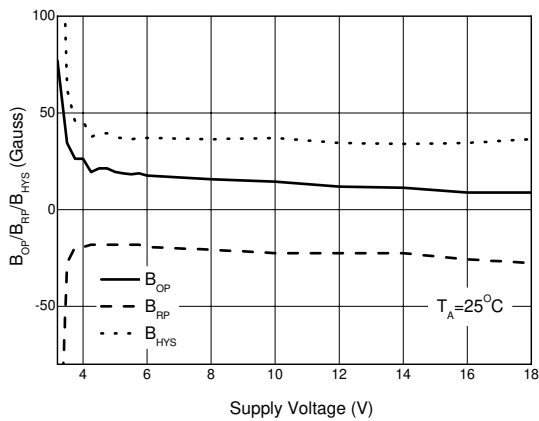

Figure 9. B<sub>OP</sub>/B<sub>RP</sub>/B<sub>HYS</sub> vs. Supply Voltage

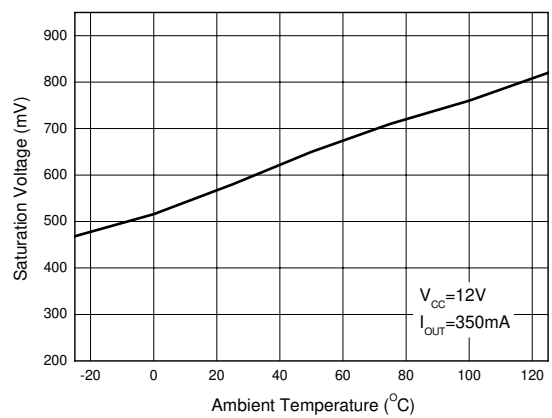

Figure 10. Saturation Voltage vs. Ambient Temperature

**Typical Performance Characteristics (Continued)**

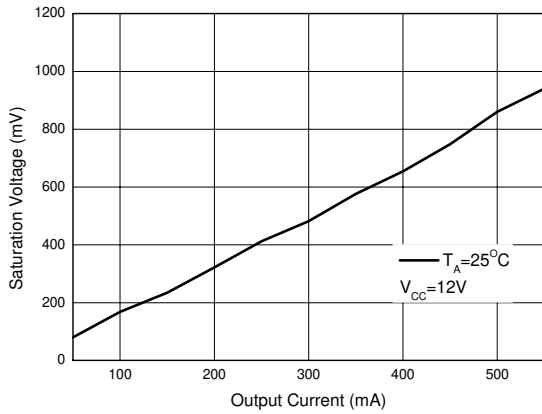

Figure 11. Saturation Voltage vs. Output Current

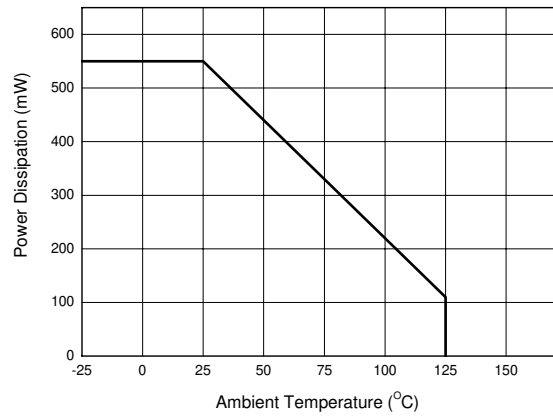

Figure 12. Power Dissipation vs. Ambient Temperature

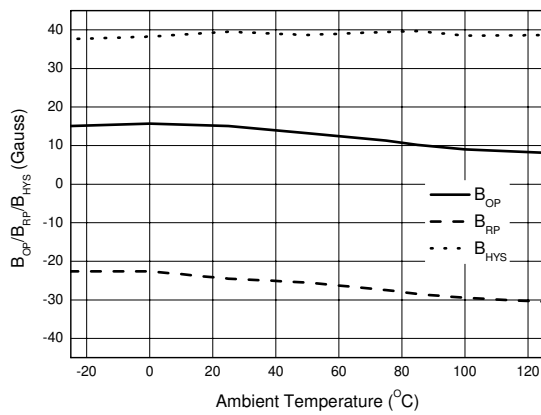

Figure 13. B<sub>OP</sub>/B<sub>RP</sub>/B<sub>HYS</sub> vs Ambient Temperature



## Typical Application

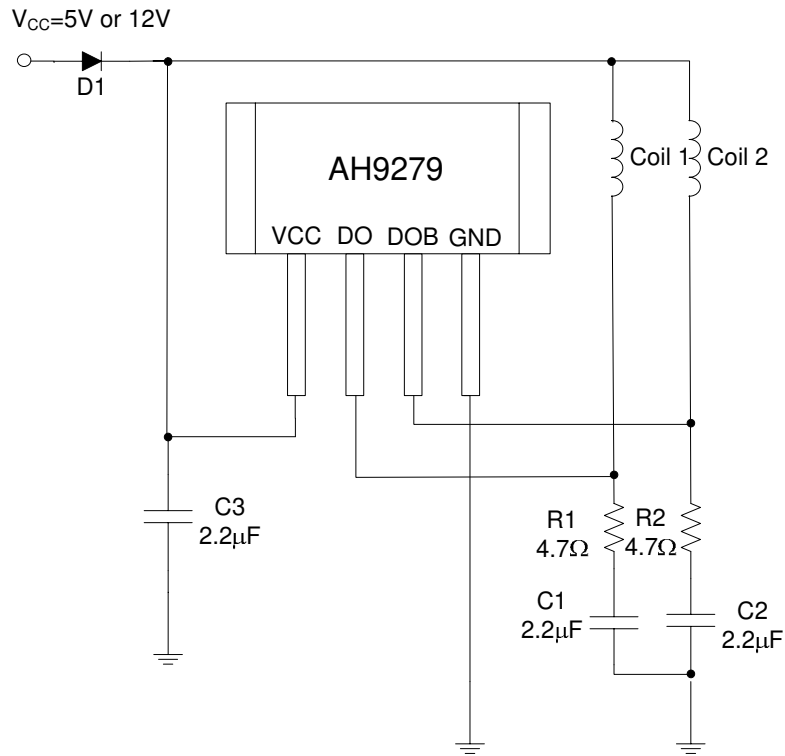

Figure 14. Typical Application 1 of AH9279 (Note 2)

### Note 2:

1. D1 is an ordinary diode used to filter the noise from VCC and protect IC if VCC and GND are plugged reversed.
2. C1=C2=C3=2.2µF typical, electrolytic capacitors are better. They should be fine tuned based on system design.
3. R1=R2=4.7Ω typical. They can be cancelled according to system requirement.

**Typical Application (Continued)**

Figure 15. Typical Application 2 of AH9279 (Note 3)

## Note 3:

1. D1 is an ordinary diode used to filter the noise from VCC and protect IC if VCC and GND are plugged reversed.
2. C1=2.2µF typical, electrolytic capacitors are better. They should be fine tuned based on system design.
3. ZD1 and ZD2 breakdown voltage are 35V.

**Mechanical Dimensions**

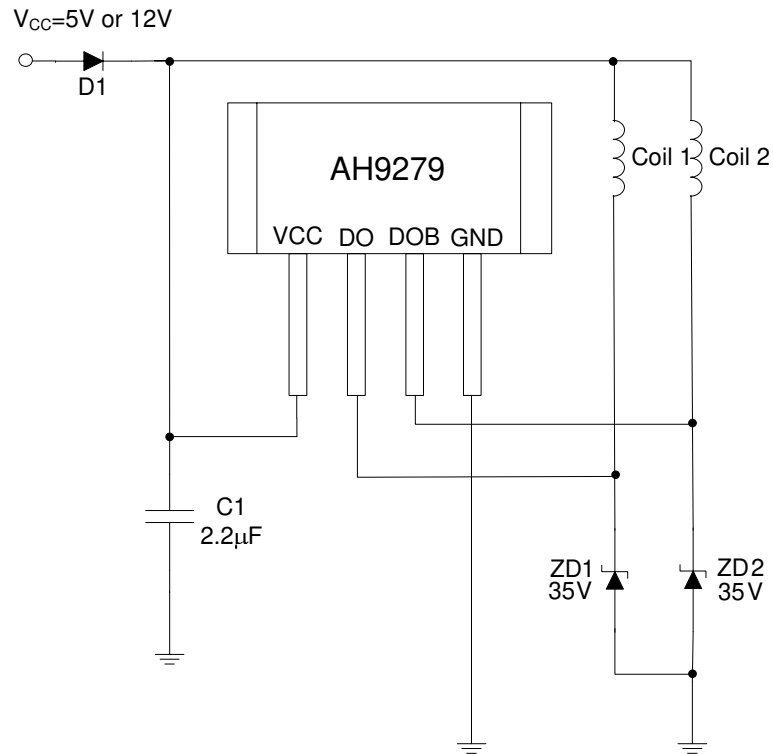
**TO-94**

**Unit: mm(inch)**

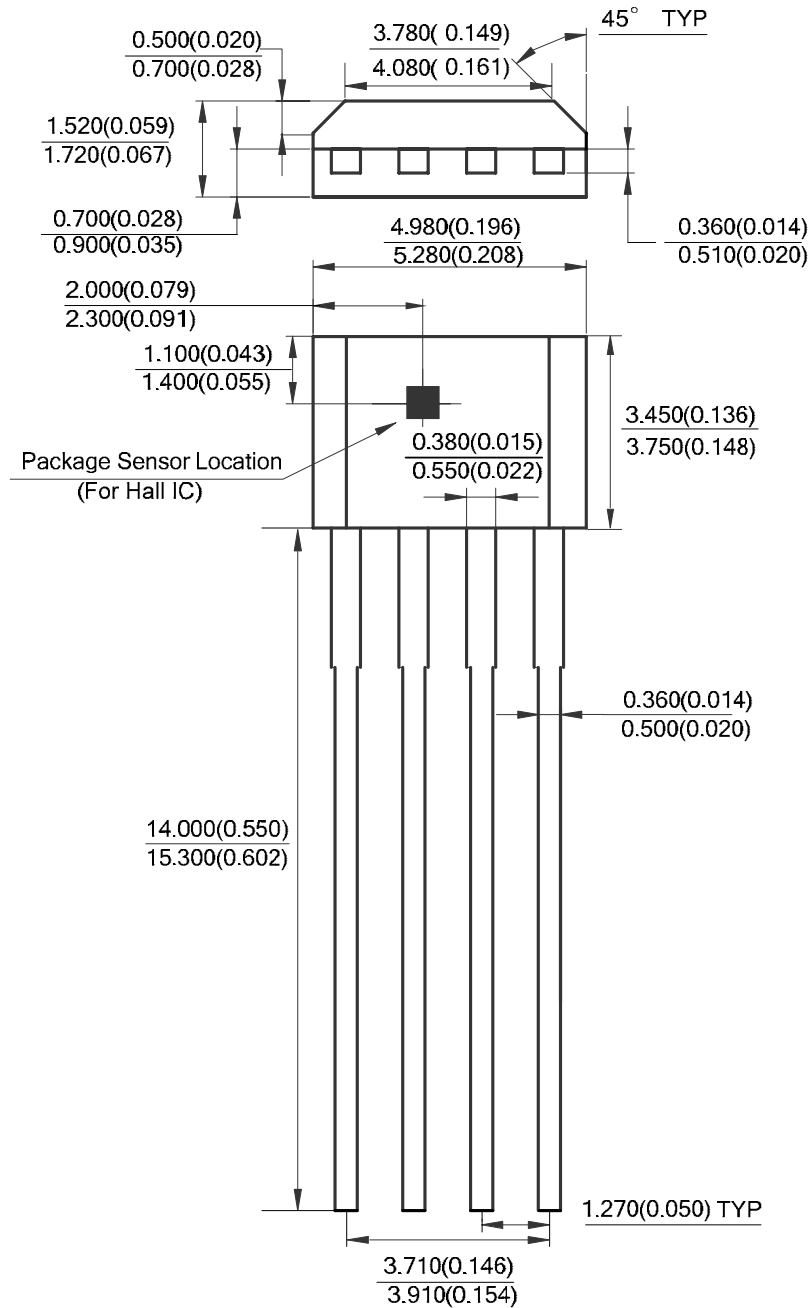



## BCD Semiconductor Manufacturing Limited

<http://www.bcdsemi.com>

### IMPORTANT NOTICE

BCD Semiconductor Manufacturing Limited reserves the right to make changes without further notice to any products or specifications herein. BCD Semiconductor Manufacturing Limited does not assume any responsibility for use of any its products for any particular purpose, nor does BCD Semiconductor Manufacturing Limited assume any liability arising out of the application or use of any its products or circuits. BCD Semiconductor Manufacturing Limited does not convey any license under its patent rights or other rights nor the rights of others.

---

#### MAIN SITE

##### - Headquarters

##### BCD Semiconductor Manufacturing Limited

No. 1600, Zi Xing Road, Shanghai Zizhu Science-based Industrial Park, 200241, China  
Tel: +86-21-24162266, Fax: +86-21-24162277

##### - Wafer Fab

##### Shanghai SIM-BCD Semiconductor Manufacturing Co., Ltd.

800 Yi Shan Road, Shanghai 200233, China  
Tel: +86-21-6485 1491, Fax: +86-21-5450 0008

#### REGIONAL SALES OFFICE

##### Shenzhen Office

##### Shanghai SIM-BCD Semiconductor Manufacturing Co., Ltd., Shenzhen Office

Unit A Room 1203, Skyworth Bldg., Gaoxin Ave. 1.S., Nanshan District, Shenzhen, China  
Tel: +86-755-8826 7951  
Fax: +86-755-8826 7865

##### Taiwan Office

##### BCD Semiconductor (Taiwan) Company Limited

4F, 298-1, Rui Guang Road, Nei-Hu District, Taipei, Taiwan  
Tel: +886-2-2656 2808  
Fax: +886-2-2656 2806

##### USA Office

##### BCD Semiconductor Corp.

30920 Huntwood Ave. Hayward, CA 94544, USA  
Tel : +1-510-324-2988  
Fax: +1-510-324-2788