

P	LTR	DESCRIPTION	DATE	DWN	APVD
	A	INITIAL RELEASE	20APR2021	SR	CB

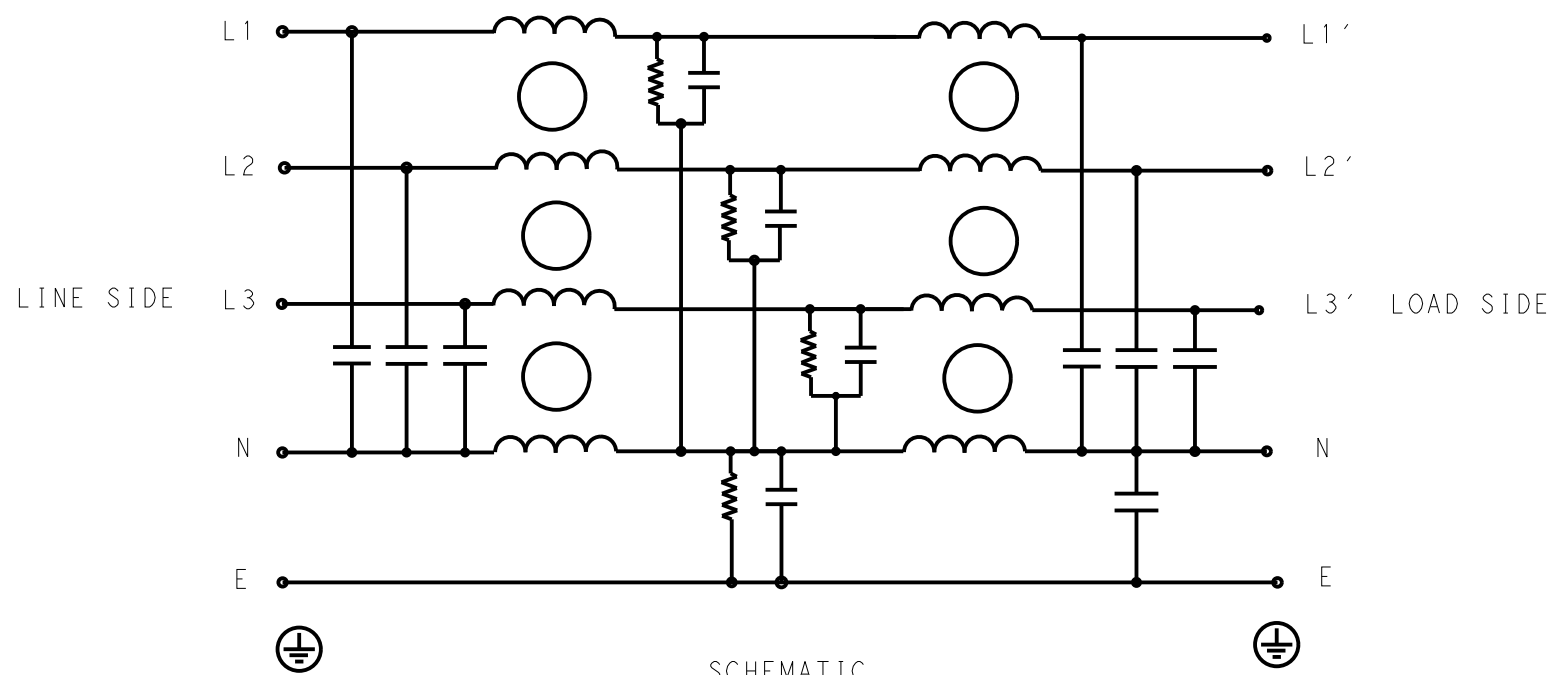

SCHEMATIC

TYPICAL INSERTION LOSS
COMMON MODE 50/50Ω; DIFFERENTIAL MODE 50/50Ω

MHz	0.01	0.05	0.15	0.5	1	3	5	10	30
CM	70	70	72	78	72	62	54	45	25
DM	50	52	36	50	50	46	40	26	30

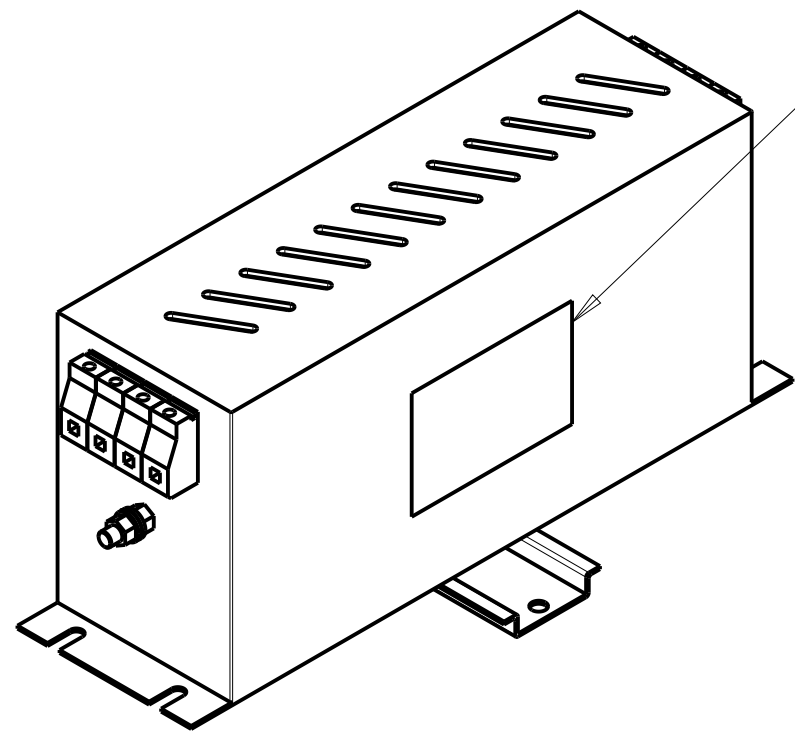

LABEL TO TE MARKING SPECIFICATION

SAFETY ORGANIZATIONS

THIS FILTER WILL BE FORMALLY RECOGNIZED, CERTIFIED OR APPROVED BY THE LISTED AGENCY. THEREFORE, ALL TEST/REQUIREMENTS SPECIFIED IN THE LATEST REVISION OF THE FOLLOWING AGENCY STANDARDS WILL BE MET:

UL APPROVED 7A 520V 50Hz/60Hz 50°C
CSA APPROVED 7A 520V 50Hz/60Hz 50°C

OPERATING SPECIFICATION

LINE CURRENT/VOLTAGE: 7A, 520VAC
LINE FREQUENCY: 50/60Hz

MAXIMUM LEAKAGE CURRENT: 5mA @ 230VAC, 50Hz

OPERATING AMBIENT TEMPERATURE RANGE @ RATED CURRENT: -10°C TO +50°C

IN AN AMBIENT, T_a, HIGHER THAN 50°C, THE MAXIMUM OPERATING CURRENT, I_o, IS AS FOLLOWS:

$$I_o = I_r \sqrt{\frac{105 - T_a}{55}}$$

RELIABILITY SPECIFICATIONS

STORAGE TEMPERATURE: -40°C TO +85°C
HUMIDITY: 21 DAYS @ 40°C AND 95% RH

TEST SPECIFICATIONS

INDUCTANCE, NOMINAL: 10mH

CAPACITANCE @ 1kHz

NEUTRAL TO GROUND, NOMINAL: 1μF
LINE TO NEUTRAL, NOMINAL: 3μF

DISCHARGE RESISTOR

L/L I.R. 2MΩ 1W
L/N I.R. 1.5MΩ 1W
L/G I.R. 2MΩ 1W
N/G I.R. 680KΩ 1W
IR (NO DISCHARGE RESISTOR) 20°C, 50% RH AND 100VDC, MIN: 6MΩ

RECOMMENDED RECEIVING INSPECITON HIPOT

LINE TO GROUND FOR 1 MINUTE: 2856VDC
LINE TO LINE FOR 1 MINUTE: 2236VDC
LINE TO NEUTRAL FOR 1 MINUTE: 1290VDC

FILTER APPROVAL

THE BEST WAY TO SELECT AND QUALIFY A FILTER IS FOR YOUR ENGINEERING TO TEST THE UNIT IN YOUR EQUIPMENT.

THIS DRAWING IS A CONTROLLED DOCUMENT.		DWN SUPREETH R 20APR2021		
		CHK CHRIS BOLLE 20APR2021		
DIMENSIONS: mm		APVD CHRIS BOLLE 20APR2021	NAME POWER LINE FILTER FOR DIN 35 RAIL INSTALLATION 7KEVD10BBSWHM	
TOLERANCES UNLESS OTHERWISE SPECIFIED:		PRODUCT SPEC -	SIZE A300779 CAGE CODE G-6-1609998-0	
0 PLC ±.5		APPLICATION SPEC -	RESTRICTED TO -	
1 PLC ±0.5		WEIGHT -	SCALE 1:2 SHEET 1 OF 2 REV A	
2 PLC ±0.40		CUSTOMER DRAWING		
3 PLC ±0.130				
4 PLC ±0.0500				
ANGLES ±.				
MATERIAL -				
FINISH -				

© 2021 TE Connectivity. All Rights Reserved.

NOTE 1 GROUND CONNECTION:
 FOR ELECTRICAL SAFETY AND FILTER PERFORMANCE
 UNIT MUST HAVE A GOOD GROUND CONNECTION.
 TORQUE OUTER TERMINAL SCREWS: 0.5Nm / 4.5 in.lbs
 TORQUE GROUND NUTS: 2Nm

NOTE 2 INPUT OUTPUT CONNECTION TERMINAL
 AWG SIZE: 26-12 AWG
 WIRE SECTION: 4 mm²
 THREADED BOLT SIZE FOR GROUND: M5

NOTE 3 SUPPLIED WITH DIN RAIL BRACKET.

NOTE 4 DRAWING SHOWS DIN RAIL FOR REFERENCE ONLY.

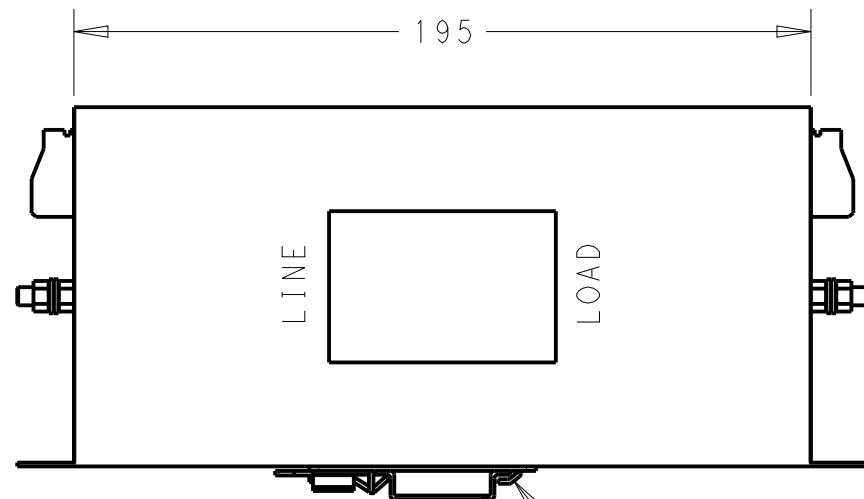
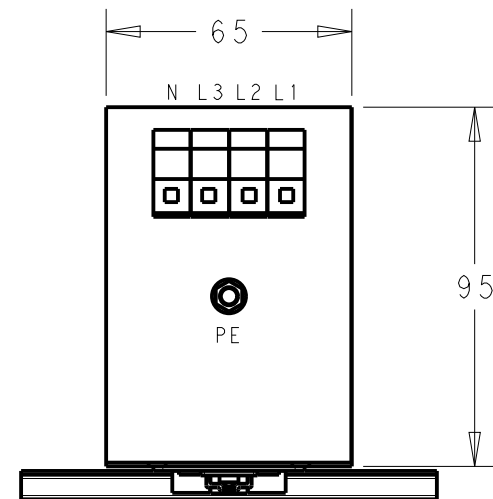

DIN RAIL CHANNEL — DIN 35 BRACKET

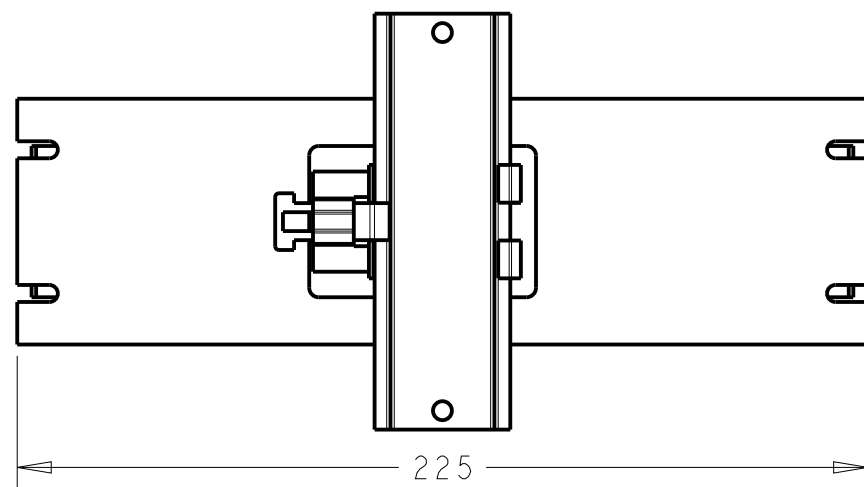

REVISIONS					
P	LTR	DESCRIPTION	DATE	DWN	APVD
		SEE SHEET 1			

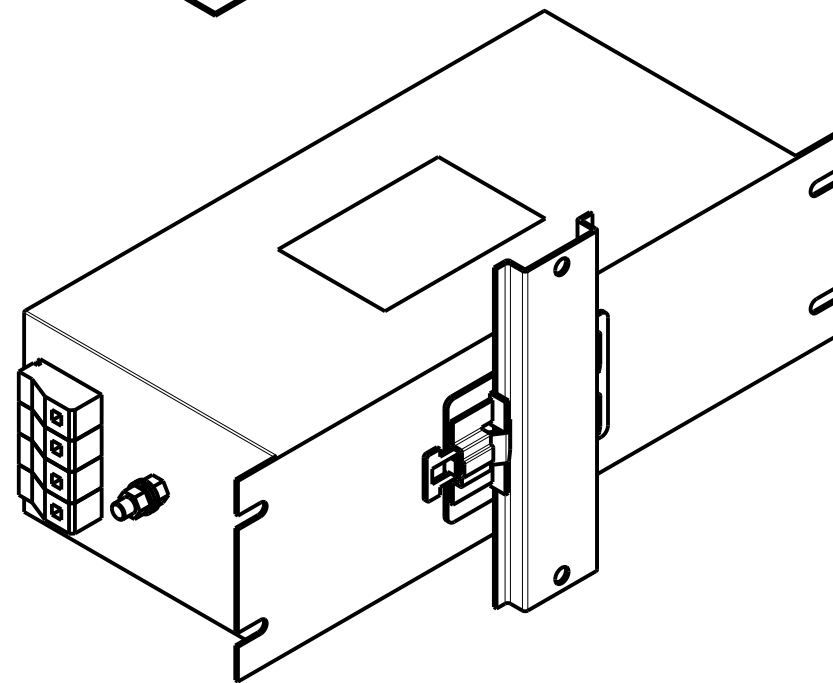
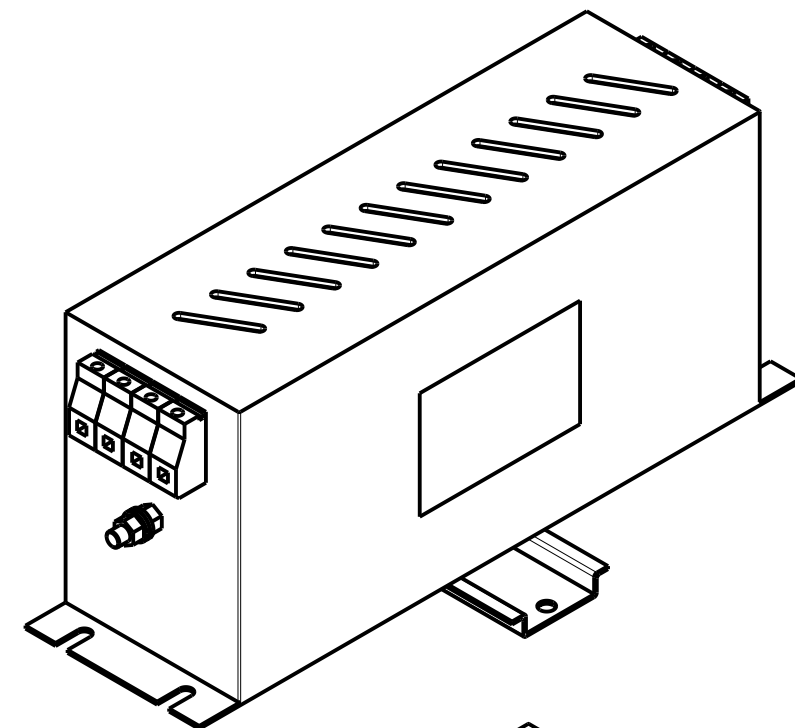

THIS DRAWING IS A CONTROLLED DOCUMENT.		DWN SUPREETH R 20APR2021		
		CHK CHRIS BOLLE 20APR2021		
		APVD CHRIS BOLLE 20APR2021	NAME POWER LINE FILTER FOR DIN 35 RAIL INSTALLATION 7KEVD10BBSWHM	
DIMENSIONS: mm		PRODUCT SPEC -	SIZE A300779	
TOLERANCES UNLESS OTHERWISE SPECIFIED:		APPLICATION SPEC -	CAGE CODE C-6-1609998-0	
MATERIAL -		WEIGHT -	DRAWING NO -	
FINISH -		RESTRICTED TO -		SCALE 1:2
		CUSTOMER DRAWING		SHEET 2 OF 2
				REV A