

REVISIONS																	
LTR	DESCRIPTION	DATE (YR-MO-DA)	APPROVED														
A	The 01FX and 02FX devices are inactive for new designs. Editorial changes throughout.	91-04-19	<i>M.L. Goral</i>														
REV																	
SHEET																	
REV																	
SHEET																	
REV STATUS OF SHEETS	REV	A	A	A			A	A			A		A				
	SHEET	1	2	3	4	5	6	7	8	9	10	11	12	13	14		
PMIC N/A	STANDARDIZED MILITARY DRAWING <small>THIS DRAWING IS AVAILABLE FOR USE BY ALL DEPARTMENTS AND AGENCIES OF THE DEPARTMENT OF DEFENSE</small>	PREPARED BY <i>Monica L. Goral</i>					DEFENSE ELECTRONICS SUPPLY CENTER DAYTON, OHIO 45444										
AMSC N/A		CHECKED BY <i>Ray Monnin</i>															
		APPROVED BY <i>M.L. Goral</i>					DRAWING APPROVAL DATE 14 MARCH 1988		SIZE A	CAGE CODE 67268	5962-8854						
REVISION LEVEL A							SHEET	1	OF	14							

1. SCOPE

1.1 Scope. This drawing describes device requirements for class B microcircuits in accordance with 1.2.1 of MIL-STD-883, "Provisions for the use of MIL-STD-883 in conjunction with compliant non-JAN devices".

1.2 Part or Identifying Number (PIN). The complete PIN shall be as shown in the following example:

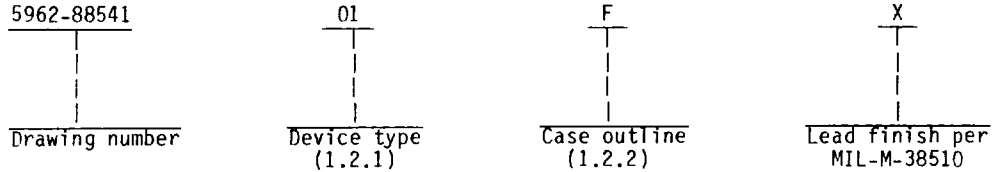

1.2.1 Device type(s). The device type(s) shall identify the circuit function as follows:

Device type	Generic number	Circuit function	Access time
01	27S13A	512 x 4-bit bipolar PROM (three-state)	40 ns
02	27S13	512 x 4-bit bipolar PROM (three-state)	60 ns

1.2.2 Case outline(s). The case outline(s) shall be as designated in appendix C of MIL-M-38510, and as follows:

Outline letter	Case outline
F	F-5 (16-lead, .440" x .285" x .085"), flat package
2	C-2 (20-terminal, .358" x .358" x .100"), square chip carrier package

1.3 Absolute maximum ratings.

Supply voltage range	-0.5 V dc to +7.0 V dc
Input voltage range	-0.5 V dc to +5.5 V dc
Storage temperature range	-65°C to +150°C
Maximum power dissipation (P_D) per device ^{1/}	715 mW
Lead temperature (soldering, 10 seconds)	+300°C
Thermal resistance, junction-to-case (θ_{JC}) ^{2/}	See MIL-M-38510, appendix C
Junction temperature (T_J)	175°C
DC voltage applied to outputs (except during programming)	-0.5 V dc to +5.5 V dc maximum
DC voltage applied to outputs during programming	21 V dc
Output current into outputs during programming (maximum duration of 1 s)	250 mA
DC input current	-30 mA to +5.0 mA

1.4 Recommended operating conditions.

Supply voltage range (V_{CC})	+4.5 V dc minimum to +5.5 V dc maximum
Minimum high-level input voltage (V_{IH})	2.0 V dc
Maximum low-level input voltage (V_{IL})	0.8 V dc
Case operating temperature range (T_C)	-55°C to +125°C

^{1/} Must withstand the added P_D due to short circuit test; e.g., I_{OS} .

^{2/} Heat sinking is recommended to reduce the junction temperature.

STANDARDIZED MILITARY DRAWING DEFENSE ELECTRONICS SUPPLY CENTER DAYTON, OHIO 45444	SIZE A	5962-88541
	REVISION LEVEL A	SHEET 2

2. APPLICABLE DOCUMENTS

2.1 Government specification, standard, and bulletin. Unless otherwise specified, the following specification, standard, and bulletin of the issue listed in that issue of the Department of Defense Index of Specifications and Standards specified in the solicitation, form a part of this drawing to the extent specified herein.

SPECIFICATION

MILITARY

MIL-M-38510 - Microcircuits, General Specification for.

STANDARD

MILITARY

MIL-STD-883 - Test Methods and Procedures for Microelectronics.

BULLETIN

MILITARY

MIL-BUL-103 - List of Standardized Military Drawings (SMD's).

(Copies of the specification, standard, and bulletin required by manufacturers in connection with specific acquisition functions should be obtained from the contracting activity or as directed by the contracting activity.)

2.2 Order of precedence. In the event of a conflict between the text of this drawing and the references cited herein, the text of this drawing shall take precedence.

3. REQUIREMENTS

3.1 Item requirements. The individual item requirements shall be in accordance with 1.2.1 of MIL-STD-883, "Provisions for the use of MIL-STD-883 in conjunction with compliant non-JAN devices" and as specified herein.

3.2 Design, construction, and physical dimensions. The design, construction, and physical dimensions shall be as specified in MIL-M-38510 and herein.

3.2.1 Terminal connections. The terminal connections shall be as specified on figure 1.

3.2.2 Truth table. The truth table shall be as specified on figure 2.

3.2.2.1 Unprogrammed devices. The truth table for unprogrammed devices shall be as specified on figure 2.

3.2.2.2 Programmed devices. The requirements for supplying programmed devices are not part of this drawing.

3.2.3 Logic diagram. The logic diagram shall be as specified on figure 3.

3.2.4 Switching test circuit. The switching test circuit shall be as specified on figure 4.

3.2.5 Switching waveforms. The switching waveforms shall be as specified on figure 5.

3.2.6 Case outline(s). The case outline(s) shall be in accordance with 1.2.2 herein.

STANDARDIZED MILITARY DRAWING DEFENSE ELECTRONICS SUPPLY CENTER DAYTON, OHIO 45444	SIZE A		5962-88541
		REVISION LEVEL A	SHEET 3

TABLE I. Electrical performance characteristics.

Test	Symbol	Conditions -55°C < T _C < +125°C 4.5 V < V _{CC} < 5.5 V unless otherwise specified	Group A subgroups	Device types	Limits		Unit	
					Min	Max		
Output high voltage	V _{OH}	V _{CC} = 4.5 V, I _{OH} = -2.0 mA V _{IH} = 2.0 V, V _{IL} = 0.8 V	1,2,3	All	2.4		V	
Output low voltage	V _{OL}	V _{CC} = 4.5 V, I _{OL} = 16 mA V _{IH} = 2.0 V, V _{IL} = 0.8 V	1,2,3			0.45	V	
Input high level current	I _{IH}	V _{CC} = 5.5 V, V _{IN} = 2.7 V	1,2,3			25	μA	
Input low level current	I _{IL}	V _{CC} = 5.5 V, V _{IN} = 0.45 V	1,2,3			-250	μA	
Power supply current	I _{CC}	V _{CC} = 5.5 V, V _{IN} = 0.0 V	1,2,3			130	mA	
Input clamp voltage	V _I	V _{CC} = 4.5 V, I _{IN} = -18 mA	1,2,3			-1.2	V	
High output leakage current	I _{OZH}	V _{CC} = 5.5 V V _{CS} = 2.4 V V _{IH} = 2.0 V	1,2,3			40	μA	
	I _{OZL}	V _{IL} = 0.8 V V _O = 0.4 V						
Output short circuit current	I _{OS}	V _{CC} = 5.5 V V _{OUT} = 0.0 V <u>1/</u>	1,2,3			-20	-90	mA
Functional tests		See 4.3.1d		7,8				
Address access time	t _{AVQV}	C _L = 50 pF S1 is closed (See figures 4 and 5)	9,10,11	01		40	ns	
				02		60		
Enable access time	t _{GVQV}	(See figures 4 and 5) <u>2/</u>	9,10,11	01		25	ns	
				02		30		
Enable recovery time	t _{GVQZ}	(See figures 4 and 5) <u>2/</u>	9,10,11	01		25	ns	
				02		30		

1/ Not more than one output should be shorted at a time and the duration of the short circuit condition should not exceed one second.

2/ t_{GVQV} is tested with C_L = 50 pF to the 1.5 V level; S1 is open for high impedance to high tests and closed for high impedance to low tests. t_{GVQZ} is tested with C_L = 5 pF. High to high impedance tests are made with S1 open to an output voltage of V_{OH} -0.5 V. Low to high impedance tests are made with S1 closed to the V_{OL} +0.5 V level.

STANDARDIZED MILITARY DRAWING	SIZE A	5962-88541
DEFENSE ELECTRONICS SUPPLY CENTER DAYTON, OHIO 45444	REVISION LEVEL	SHEET 4

3.3 Electrical performance characteristics. Unless otherwise specified herein, the electrical performance characteristics are as specified in table I and apply over the full case operating temperature range.

3.4 Electrical test requirements. The electrical test requirements shall be the subgroups specified in table II. The electrical tests for each subgroup are described in table I.

3.5 Marking. Marking shall be in accordance with MIL-STD-883 (see 3.1 herein). The part shall be marked with the PIN listed in 1.2 herein. In addition, the manufacturer's PIN may also be marked as listed in MIL-BUL-103 (see 6.6 herein).

3.6 Processing options. Since the PROM is an unprogrammed memory capable of being programmed by either the manufacturer or the user to result in a wide variety of PROM configurations, two processing options are provided for selection in the contract, using an altered item drawing.

3.6.1 Unprogrammed PROM delivered to the user. All testing shall be verified through group A testing as defined in 4.3.1. It is recommended that users perform subgroups 7 and 9 after programming to verify the specific program configuration.

3.6.2 Manufacturer-programmed PROM delivered to the user. All testing requirements and quality assurance provisions herein, including the requirements of the altered item drawing shall be satisfied by the manufacturer prior to delivery.

3.7 Certificate of compliance. A certificate of compliance shall be required from a manufacturer in order to be listed as an approved source of supply in MIL-BUL-103 (see 6.6 herein). The certificate of compliance submitted to DESC-ECS prior to listing as an approved source of supply shall affirm that the manufacturer's product meets the requirements of MIL-STD-883 (see 3.1 herein) and the requirements herein.

3.8 Certificate of conformance. A certificate of conformance as required in MIL-STD-883 (see 3.1 herein) shall be provided with each lot of microcircuits delivered to this drawing.

3.9 Notification of change. Notification of change to DESC-ECS shall be required in accordance with MIL-STD-883 (see 3.1 herein).

3.10 Verification and review. DESC, DESC's agent, and the acquiring activity retain the option to review the manufacturer's facility and applicable required documentation. Offshore documentation shall be made available onshore at the option of the reviewer.

4. QUALITY ASSURANCE PROVISIONS

4.1 Sampling and inspection. Sampling and inspection procedures shall be in accordance with section 4 of MIL-M-38510 to the extent specified in MIL-STD-883 (see 3.1 herein).

4.2 Screening. Screening shall be in accordance with method 5004 of MIL-STD-883, and shall be conducted on all devices prior to quality conformance inspection. The following additional criteria shall apply:

- a. Burn-in test, method 1015 of MIL-STD-883.
 - (1) Test condition C or D using the circuit submitted with the certificate of compliance (see 3.7 herein).
 - (2) $T_A = +125^{\circ}\text{C}$, minimum.
- b. Interim and final electrical test parameters shall be as specified in table II herein, except interim electrical parameter tests prior to burn-in are optional at the discretion of the manufacturer.

STANDARDIZED MILITARY DRAWING DEFENSE ELECTRONICS SUPPLY CENTER DAYTON, OHIO 45444	SIZE A		5962-88541
		REVISION LEVEL A	SHEET 5

4.3 Quality conformance inspection. Quality conformance inspection shall be in accordance with method 5005 of MIL-STD-883 including groups A, B, C, and D inspections. The following additional criteria shall apply.

4.3.1 Group A inspection.

- a. Tests shall be as specified in table II herein.
- b. Subgroups 4, 5, and 6 in table I, method 5005 of MIL-STD-883 shall be omitted.
- c. Unprogrammed devices shall be tested for programmability and ac performance compliance to the requirements of group A, subgroups 9, 10, and 11. Either of two techniques is acceptable.
 - (1) Testing the entire lot using additional built-in test circuitry which allows the manufacturer to verify programmability and ac performance without programming the user array. If this is done, the resulting test pattern shall be verified on all devices during subgroups 9, 10, and 11, group A testing in accordance with the sampling plan specified in MIL-STD-883, method 5005.
 - (2) If such compliance cannot be tested on an unprogrammed device, a sample shall be selected to satisfy programmability requirements prior to performing subgroups 9, 10, and 11. Twelve devices shall be submitted to programming (see 3.2.2.2). If more than two devices fail to program, the lot shall be rejected. At the manufacturer's option, the sample may be increased to 24 total devices with no more than four total device failures allowed. Ten devices from the programmability sample shall be submitted to the requirements of group A, subgroups 9, 10, and 11. If more than two total devices fail, the lot shall be rejected. At the manufacturer's option, the sample may be increased to 20 total devices with no more than four total device failures allowable.
- d. Subgroups 7 and 8 shall include verification of the truth table.

4.3.2 Groups C and D inspections.

- a. End-point electrical parameters shall be as specified in table II herein.
- b. Steady-state life test conditions, method 1005 of MIL-STD-883.
 - (1) Test condition C or D using the circuit submitted with the certificate of compliance (see 3.7 herein).
 - (2) $T_A = +125^{\circ}\text{C}$, minimum.
 - (3) Test duration: 1,000 hours, except as permitted by method 1005 of MIL-STD-883.
- c. The group C, subgroup 1 sample shall include devices tested in accordance with 4.3.1.c.

STANDARDIZED MILITARY DRAWING DEFENSE ELECTRONICS SUPPLY CENTER DAYTON, OHIO 45444	SIZE A	5962-88541
		REVISION LEVEL A

Case F

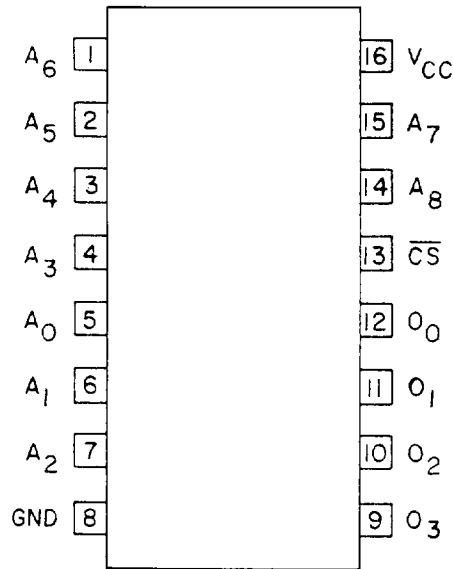

Case 2

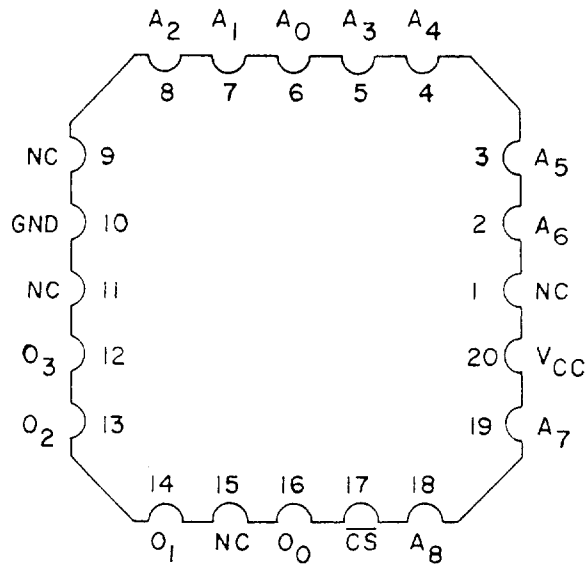

FIGURE 1. Terminal connections.

STANDARDIZED MILITARY DRAWING DEFENSE ELECTRONICS SUPPLY CENTER DAYTON, OHIO 45444	SIZE A	5962-88541
	REVISION LEVEL	SHEET 7

Word number	Enable \overline{CS}	Address									Output			
		A ₈	A ₇	A ₆	A ₅	A ₄	A ₃	A ₂	A ₁	A ₀	O ₃	O ₂	O ₁	O ₀
NA	L	X	X	X	X	X	X	X	X	X	L	L	L	L
	H	X	X	X	X	X	X	X	X	X	OC	OC	OC	OC

NOTES:

NA = Not applicable

X = Input may be high level, low level, or open circuit.

OC = Open circuit (high resistance output).

FIGURE 2. Truth table (unprogrammed).

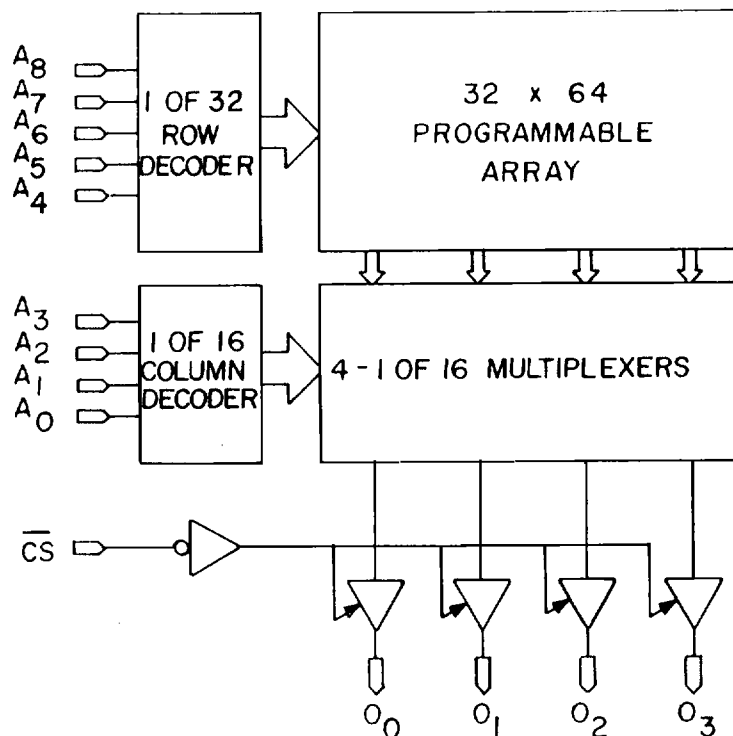
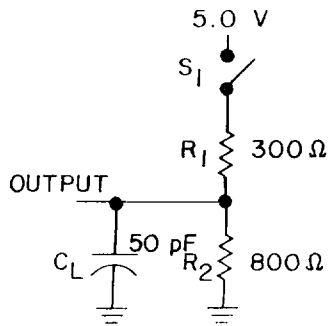

FIGURE 3. Logic diagram.

STANDARDIZED MILITARY DRAWING DEFENSE ELECTRONICS SUPPLY CENTER DAYTON, OHIO 45444	SIZE A	5962-88541
	REVISION LEVEL	SHEET 8



Output load for all tests except t_{GVQZ}

Test circuit A

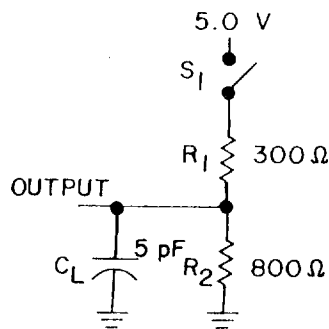

Output load for t_{GVQZ}

Test circuit B

FIGURE 4. Switching test circuit or equivalent.

NOTES:

1. All device test loads should be located within 2" of device output pin.
2. S_1 is open for output data high to Hi-Z and Hi-Z to output data high tests. S_1 is closed for all other AC tests.
3. Load capacitance includes all stray and fixture capacitance.

STANDARDIZED MILITARY DRAWING DEFENSE ELECTRONICS SUPPLY CENTER DAYTON, OHIO 45444	SIZE A	5962-88541
		REVISION LEVEL

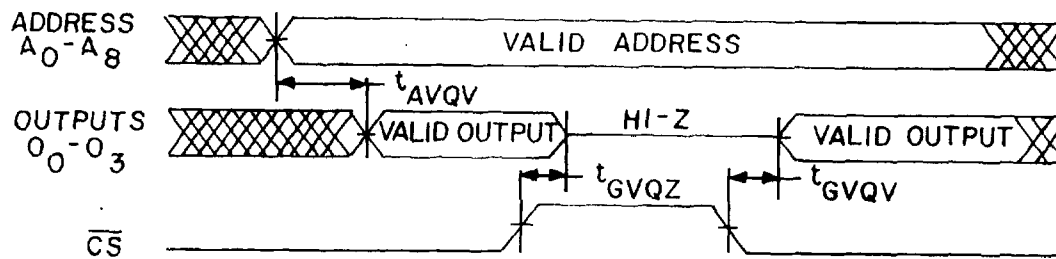

FIGURE 5. Switching waveforms.

STANDARDIZED MILITARY DRAWING DEFENSE ELECTRONICS SUPPLY CENTER DAYTON, OHIO 45444	SIZE A		5962-88541
		REVISION LEVEL	SHEET 10

TABLE II. Electrical test requirements.

MIL-STD-883 test requirements	Subgroups (per method 5005, table I)
Interim electrical parameters (method 5004)	---
Final electrical test parameters (method 5004)	1*, 2, 3, 7*, 8, 9, 10**, 11**
Group A test requirements (method 5005)	1, 2, 3, 7, 8, 9, 10**, 11**
Groups C and D end-point electrical parameters (method 5005)	1, 2, 3

* PDA applies to subgroups 1 and 7.

** Subgroups 10 and 11, if not tested, shall be guaranteed to the limits specified in table I.

4.4 Programming procedures for method A.

- a. Connect the device in the electrical configuration for programming. The waveforms on figure 6 and the programming characteristics of table III shall apply to these procedures.
- b. Terminate all outputs to V_{ONP} through a pull-up resistor R.
- c. Apply V_{CCP} to V_{CC} .
- d. Connect \overline{CS} to V_{ILP} .
- e. Address the PROM with the binary address of the selected word to be programmed.
- f. After a delay of t_1 , apply V_{OP} for a duration of t_p + rise time of \overline{CS} input + t_2 to the output selected for programming. After a delay of t_2 + rise time of programmed output, apply V_{CSP} for a duration of t_p + rise time of programmed output + t_3 to the \overline{CS} input; \overline{CS} is then reduced to V_{ILP} .
- g. After a delay of t_4 , opening of the fuse is verified. During verification, V_{CC} remains unchanged at V_{CCP} .
- h. The outputs should be programmed one at a time, since the internal decoding circuitry is capable of sinking only one unit of programming current at a time. Note that the PROM is supplied with fuses generating a low level logic output. Programming a fuse will cause the output to go to a high level logic in the verify mode.
- i. Repeat steps 4.4a through 4.4g for all bits to be programmed.
- j. If any unit does not verify as programmed, it shall be considered a programming reject.

STANDARDIZED MILITARY DRAWING DEFENSE ELECTRONICS SUPPLY CENTER DAYTON, OHIO 45444	SIZE A	5962-88541
	REVISION LEVEL A	SHEET 11

TABLE III. Programming characteristics for method A.

Test	Symbol	Conditions $T_C = +25^\circ\text{C}$ $4.5\text{ V} \leq V_{CC} \leq 5.5\text{ V}$	Limits		Unit
			Min	Max	
V _{CC} during programming	V _{CCP}		5.0	5.5	V
High level input voltage during programming	V _{IHP}		2.4	5.5	V
Low level input voltage during programming	V _{ILP}		0.0	0.45	V
Chip select voltage during programming	V _{CSP}		14.5	15.5	V
Output voltage during programming	V _{OP}		19.5	20.5	V
Voltage on outputs not to be programmed	V _{ONP}		0	V _{CCP} +0.3	V
Current into outputs not to be programmed	I _{ONP}			20	mA
Rate of output voltage change	$\frac{d(V_{OP})}{dt}$		20	250	V/ μs
Rate of chip select voltage change	$\frac{d(V_{CS})}{dt}$		100	1000	V/ μs
Programming period	t _p		50	100	μs

5. PACKAGING

5.1 Packaging requirements. The requirements for packaging shall be in accordance with MIL-M-38510.

6. NOTES

6.1 Intended use. Microcircuits conforming to this drawing are intended for use when military specifications do not exist and qualified military devices that will perform the required function are not available for OEM application. When a military specification exists and the product covered by this drawing has been qualified for listing on QPL-38510, the device specified herein will be inactivated and will not be used for new design. The QPL-38510 product shall be the preferred item for all applications.

STANDARDIZED MILITARY DRAWING DEFENSE ELECTRONICS SUPPLY CENTER DAYTON, OHIO 45444	SIZE A		5962-88541
		REVISION LEVEL	SHEET 12

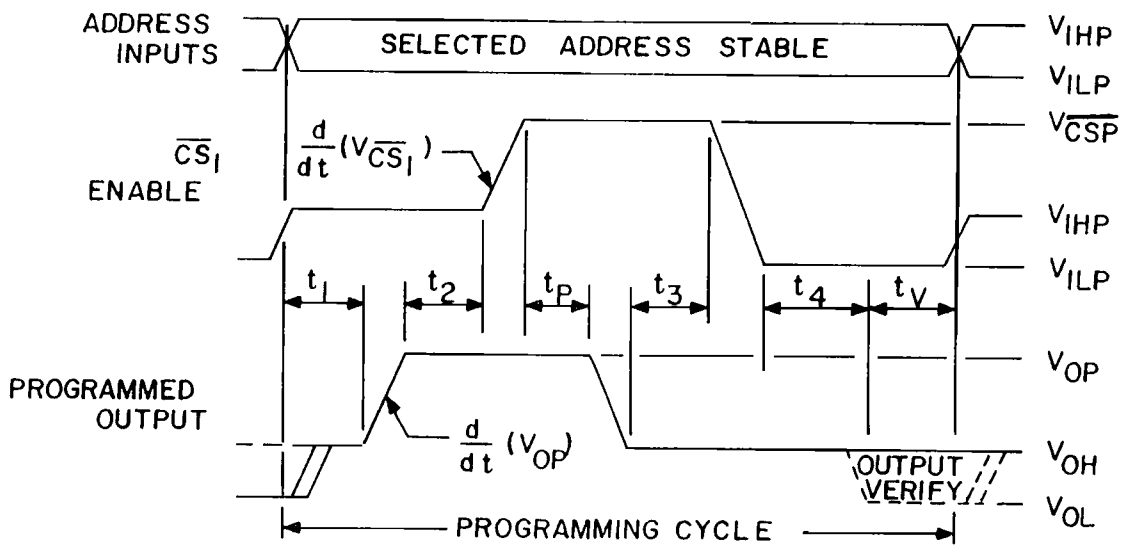

FIGURE 6. Programming waveform.

STANDARDIZED MILITARY DRAWING DEFENSE ELECTRONICS SUPPLY CENTER DAYTON, OHIO 45444	SIZE A	5962-88541
	REVISION LEVEL	SHEET 13

6.2 Replaceability. Replaceability is determined as follows:

- a. Microcircuits covered by this drawing will replace the same generic device covered by a contractor-prepared specification or drawing.
- b. When a QPL source is established, the device specified in this drawing will be replaced by the microcircuit identified as PIN M38510/204B--.

6.3 Configuration control of SMD's. All proposed changes to existing SMD's will be coordinated with the users of record for the individual documents. This coordination will be accomplished in accordance with MIL-STD-481 using DD Form 1693, Engineering Change Proposal (Short Form).

6.4 Record of users. Military and industrial users shall inform Defense Electronics Supply Center when a system application requires configuration control and the applicable SMD. DESC will maintain a record of users and this list will be used for coordination and distribution of changes to the drawings. Users of drawings covering microelectronics devices (FSC 5962) should contact DESC-ECS, telephone (513) 296-6022.

6.5 Comments. Comments on this drawing should be directed to DESC-ECS, Dayton, Ohio 45444, or telephone (513) 296-5375.

6.6 Approved sources of supply. Approved sources of supply are listed in MIL-BUL-103. The vendors listed in MIL-BUL-103 have agreed to this drawing and a certificate of compliance (see 3.6 herein) has been submitted to and accepted by DESC-ECS.

STANDARDIZED MILITARY DRAWING DEFENSE ELECTRONICS SUPPLY CENTER DAYTON, OHIO 45444	SIZE A		5962-88541
		REVISION LEVEL A	SHEET 14

STANDARDIZED MILITARY DRAWING SOURCE APPROVAL BULLETIN

DATE: 91-04-19

Approved sources of supply for SMD 5962-88541 are listed below for immediate acquisition only and shall be added to MIL-BUL-103 during the next revision. MIL-BUL-103 will be revised to include the addition or deletion of sources. The vendors listed below have agreed to this drawing and a certificate of compliance has been submitted to and accepted by DESC-ECS. This bulletin is superseded by the next dated revision of MIL-BUL-103.

Standardized Military drawing PIN	Vendor CAGE number	Vendor similar PIN	Replacement military specification PIN
5962-8854101FX	<u>2/</u>	AM27S13A/BFA	M38510/20404BFX
5962-88541012X	34335	AM27S13A/B2A	
5962-8854102FX	<u>2/</u>	AM27S13/BFA	M38510/20404BFX
5962-88541022X	34335	AM27S13/B2A	

1/ Caution. Do not use this number for item acquisition. Items acquired to this number may not satisfy the performance requirements of this drawing.

2/ Inactive for new design, use M38510/20404BFX

<u>Vendor CAGE number</u>	<u>Vendor name and address</u>	<u>Programming procedure</u>	<u>Fusible link</u>
34335	Advanced Micro Devices, Incorporated 901 Thompson Place P.O. Box 3453 Sunnyvale, CA 94088	A	Platinum silicide fuse

The information contained herein is disseminated for convenience only and the Government assumes no liability whatsoever for any inaccuracies in this information bulletin.