

DRAWING NUMBER	ISSUE
516-254-091-109	5
PART NUMBER	
516-254-091-109	

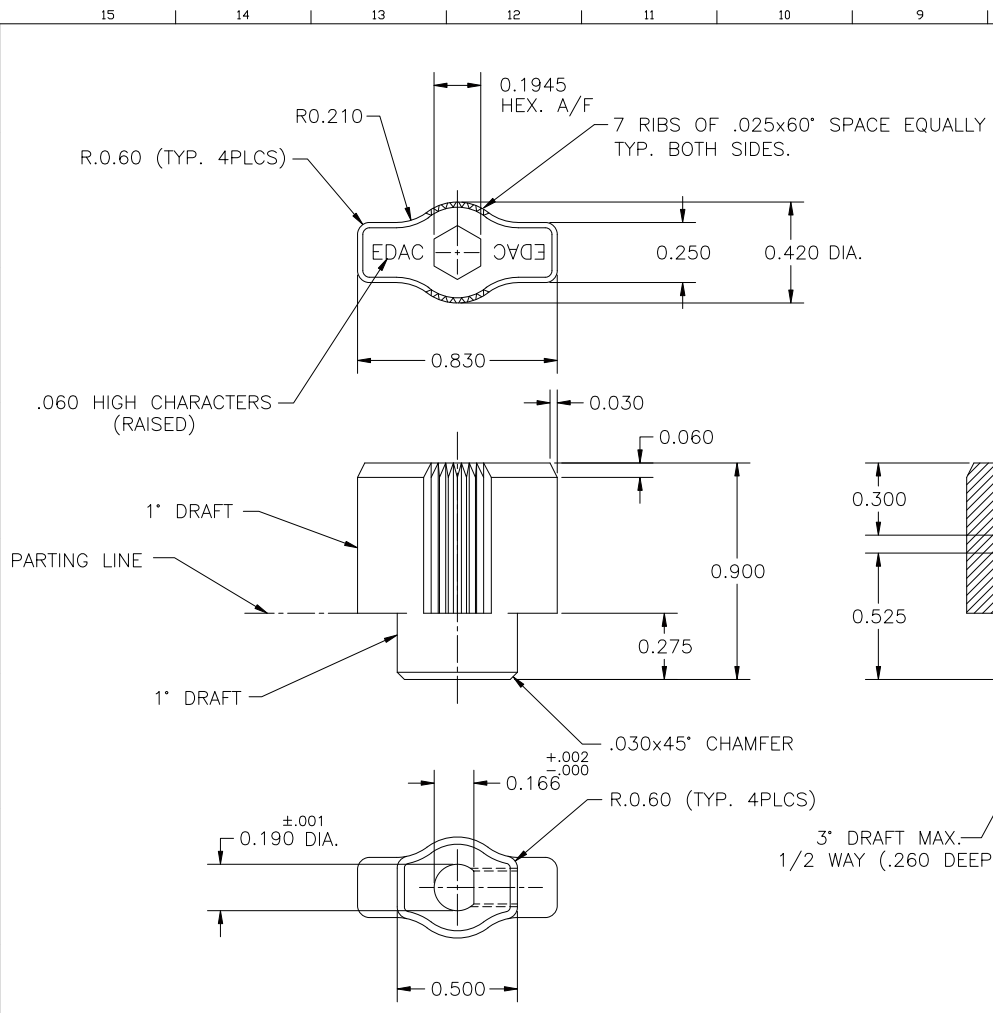

NOTES:

- 1- MATERIAL: ZINC DIECAST ZAMAK 5.
- 2- STD. PLATING (EDAC SPEC. 81/10, CODE 109) ZINC PLATING (ELECTRODEPOSITED) .0002" TO .0004" THICK WITH BLACK DYED CHROMATE FINISH.
- 3- THE GAUGE SHOWN IN FIGURE "A" SHALL SLIDE FREELY INTO THE SHAFT OPENING OF THE KNOB AFTER ALL PLATING AND TAPPING OPERATIONS ARE COMPLETED.
- 4- 8-32 SOCKET SET SCREW FLAT POINT 3/16 LONG MUST BE INSTALL AFTER PLATED.

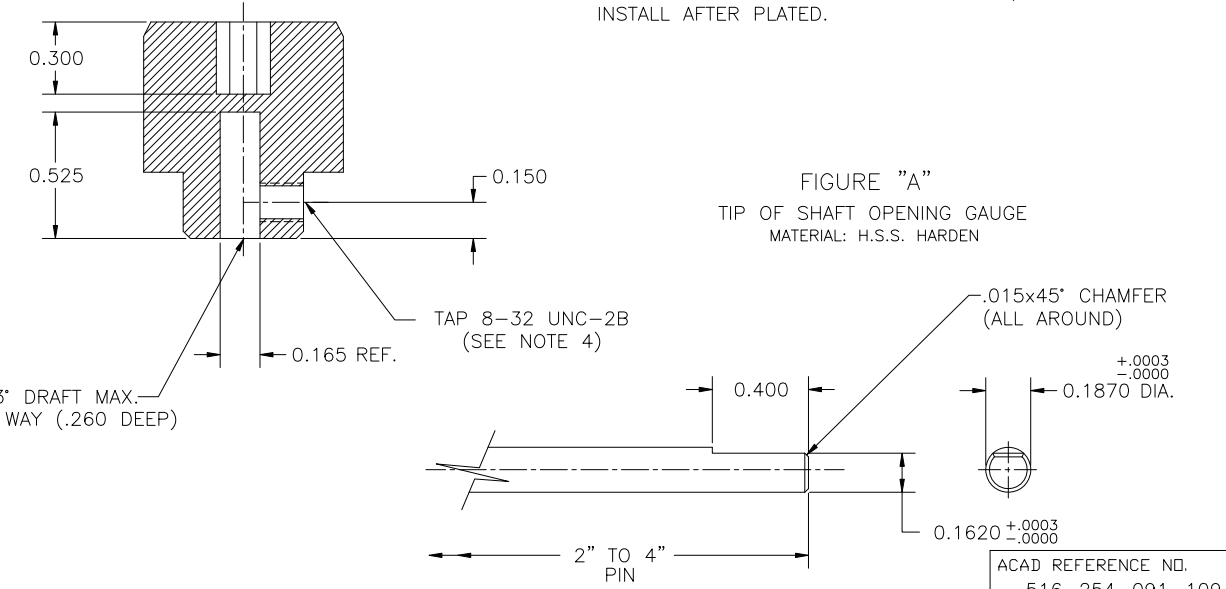

ACAD REFERENCE NO.
516-254-091-109

RECOMMENDED: DISPOSITION OF STOCK (PRIOR ISSUE PARTS)	ISSUE NUMBER	① ORIGINAL	② PARTING LINE AND DRAFT ADDED. AND DWG. N° WAS SK-970505 F.BRIONES FEB.12/96	③ NOTE 4 ADDED F.BRIONES OCT. 9/97	④ DWG.NO. CHANGE TO P/T NO. F.BRIONES JAN.17/00	⑤ ROTATED HEX J.LEE JULY 23/09
<input type="checkbox"/> SCRAP	<input type="checkbox"/> INSPECT	<input type="checkbox"/> USE AS IS	<input type="checkbox"/> REWORK	<input type="checkbox"/> SEE ENGINEERING MEMO		

TOLERANCE UNLESS NOTED		KNOB	
DIMENSION	TOLERANCE		
.00	± .		
.000	± .005		
.0000	± .		
ANGULAR	± .		
DRAWING NOTES: 1) DO NOT SCALE DRAWING. 2) DIMENSIONS ARE IN INCHES AND INCLUDE THICKNESS OF PLATING. 3) ALL SCREW THREADS TO BE CLASS 2 FIT (AMSTD.) UNLESS OTHERWISE SPECIFIED.		THIRD ANGLE PROJECTION	DRAWN: F.BRIONES DATE: FEB.5/97 CHECKED: DATE: ENG.APPR: DATE: SCALE: SHEET 1 OF 1
EDAC EDAC INC TORONTO, ONTARIO CANADA YOUR CONNECTION TO QUALITY & SERVICE		THESE DRAWINGS AND SPECIFICATIONS ARE THE PROPERTY OF EDAC INC. AND SHALL NOT BE REPRODUCED, OR COPIED OR USED AS THE BASIS FOR THE MANUFACTURE OR SALE OF APPARATUS WITHOUT WRITTEN PERMISSION.	
DRAWING NUMBER		ISSUE	
516-254-091-109		5	