

CUSTOMER DRAWING

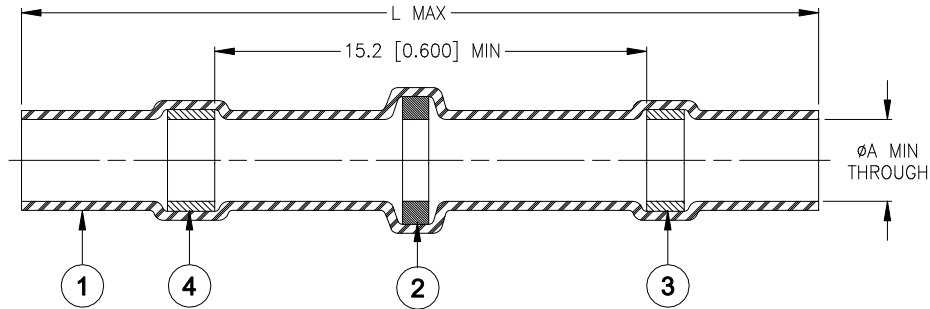

Product Name	Product Dimensions		Cable Dimensions			Qty: Item 2
	L max	ØA min	B max	ØC min	ØD min	
B-155-3801	26.0 [1.025]	1.7 [0.065]	1.7 [[0.065]	0.9 [0.035]	0.4 [0.015]	1
B-155-3802		1.95 [0.075]	1.95 [0.075]	1.1 [0.045]	0.6 [0.025]	1
B-155-3803	42.0 [1.655]	2.7 [0.105]	2.7 [0.105]	1.8 [0.070]	1.3 [0.050]	1
B-155-3805		4.5 [0.180]	4.5 [0.180]	2.3 [0.090]	1.8 [0.070]	1
B-155-3806		6.0 [0.235]	6.0 [0.235]	3.3 [0.130]	2.8 [0.110]	1
B-155-3807		7.0 [0.275]	7.0 [0.275]	3.7 [0.145]	3.2 [0.125]	1
B-155-3809		8.7 [0.340]	8.7 [0.340]	4.2 [0.165]	3.7 [0.145]	2
B-155-3810		9.7 [0.382]	9.7 [0.382]	6.8 [0.268]	6.0 [0.236]	2
B-155-3811		10.7 [0.420]	10.7 [0.420]	7.1 [0.280]	6.6 [0.260]	2
B-155-3813		13.0 [0.510]	13.0 [0.510]	8.9 [0.350]	8.4 [0.330]	1

MATERIAL

- INSULATION SLEEVE: Heat-shrinkable, transparent clear, radiation cross-linked modified polyolefin.
- SOLDER PREFORM WITH FLUX: Qty: see table (one solder washer shown).
 SOLDER: TYPE Sn42Bi58 per ANSI / J-STD-006.
 FLUX: TYPE ROM1 per ANSI / J-STD-004.
- MELTABLE RING: Thermally stabilized thermoplastic. Color: clear.
- MELTABLE RING: Thermally stabilized thermoplastic. Color: blue.

APPLICATION

- These controlled soldering devices are designed for termination of a bare or tin-plated copper shield on a cable, having an Insulation rated for at least +85°C minimum.
- Temperature range: -55°C to +125°C.
- When installed properly, it will meet the performance requirements of TE Connectivity / Raychem Specification RT-1404.
- For installation procedure and application equipment consult RPIP-824-00 or H54286.

For best results, prepare the cable as shown:

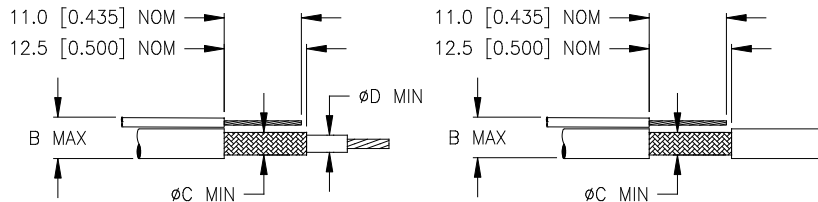

		Raychem DEVICES		TITLE: SOLDERSLEEVE ONE STEP SHIELD TERMINATOR, LEAD-FREE*									
Unless otherwise specified dimensions are in millimeters. [Inches dimensions are shown in brackets]				DOCUMENT NO.: B-155-38XX									
TOLERANCES: 0.00 N/A 0.0 N/A 0 N/A		ANGLES: N/A ROUGHNESS IN MICRON		TE Connectivity reserves the right to amend this drawing at any time. Users should evaluate the suitability of the product for their application.		Rev: C		DATE: 21-Apr-2020					
PREPARED BY: L RODRIGUEZ		ECO NUMBER: ECO-20-005249		REPLACES: D050171		CAGE CODE : 06090		SCALE: NTS		SIZE: A		SHEET: 1 of 1	

© 2020 TE Connectivity Ltd. Family of Companies. All Rights Reserved.

If this document is printed it becomes uncontrolled. Check for the latest revision.

*TE Connectivity, TE connectivity (logo), Raychem, SolderSleeve are trademarks