

# CERAMIC SURFACE MOUNT LOW PROFILE MICROPROCESSOR CRYSTAL



7.2 x 5.2 x 1.1 mm

ABMM1



## FEATURES:

- Suitable for RoHS reflow profile
- Low height 1.1mm
- Ideal for thin equipment
- AT cut offers a tight tolerance and stability  $\pm 50$ ppm

## APPLICATIONS:

- Computers, Modems, Microprocessors
- Communication, Test equipment
- PCMCIA

## STANDARD SPECIFICATIONS:

PARAMETERS	
ABRACON P/N	ABMM1 Series
Frequency Range	6.0 MHz to 125 MHz
Operation Mode	AT-cut 6.0 MHz ~ 33.0 MHz (Fundamental: Standard) 33.01 MHz ~ 125 MHz (Third-Overtone: Standard) 33.01 MHz ~ 50.0 MHz (Fundamental: See options)
Operating Temperature	-10°C to +60°C (see options)
Storage Temperature	-40°C to +85°C
Frequency Tolerance at +25°C	$\pm 50$ ppm max. (see options)
Frequency Stability over the Operating Temp. (Ref to +25°C)	$\pm 50$ ppm max. (see options)
Equivalent Series Resistance	See Table 1
Shunt Capacitance $C_0$	7pF max.
Load Capacitance $C_L$	18pF (see options)
Drive Level	500 $\mu$ W max., 100 $\mu$ W typical
Aging at 25°C First Year	$\pm 5$ ppm max.
Insulation Resistance	500Mohms min at 100Vdc $\pm 15$ V

TABLE 1

Frequency (MHz)	ESR ( $\Omega$ ) max.	Frequency (MHz)	ESR ( $\Omega$ ) max.
6.000 - 11.999(Fund)	70	20.000 - 50.000(Fund)	40
12.000 - 20.000(Fund)	50	33.000 - 125.00(3rd O/T)	80

## OPTIONS & PART IDENTIFICATION:

(Left blank if standard)

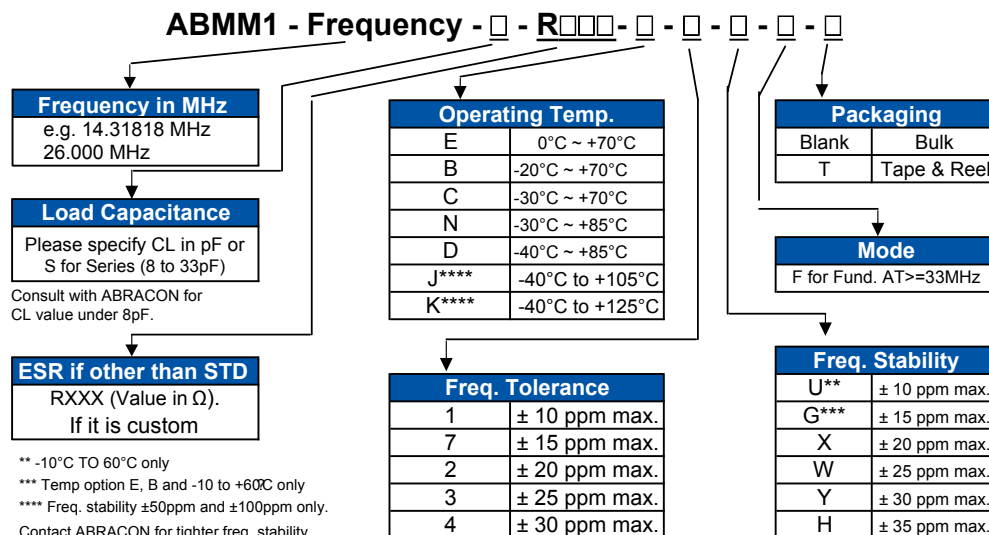

# CERAMIC SURFACE MOUNT LOW PROFILE MICROPROCESSOR CRYSTAL



7.2 x 5.2 x 1.1 mm

ABMM1



RoHS  
Compliant

## OUTLINE DRAWING:

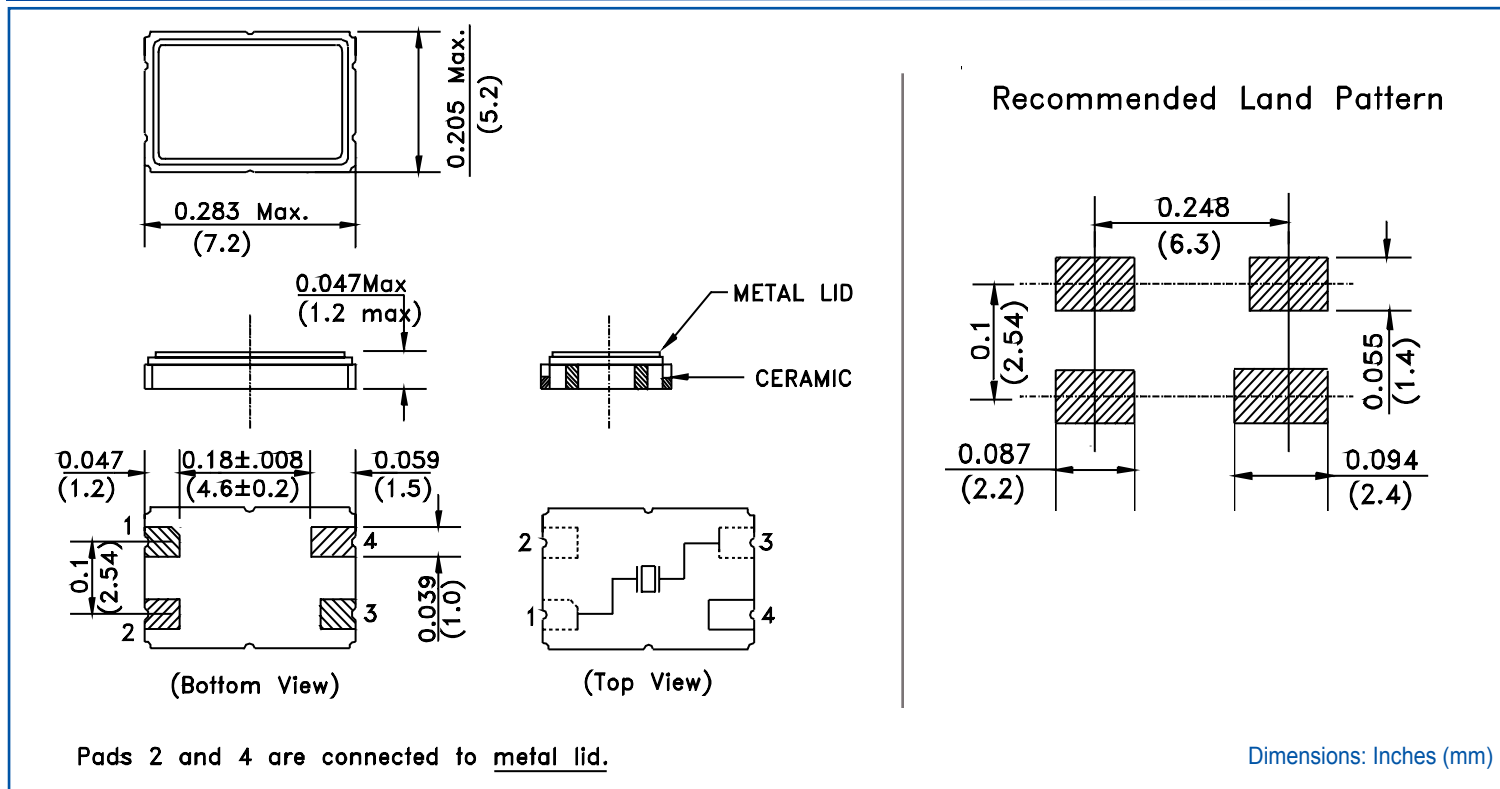

## TAPE & REEL: Tape and reel (1,000pcs/reel)

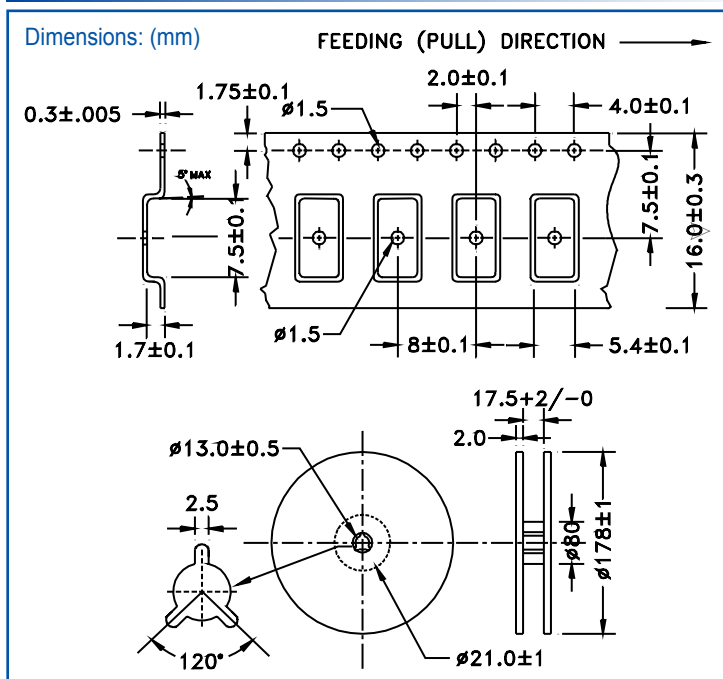

## REFLOW PROFILE

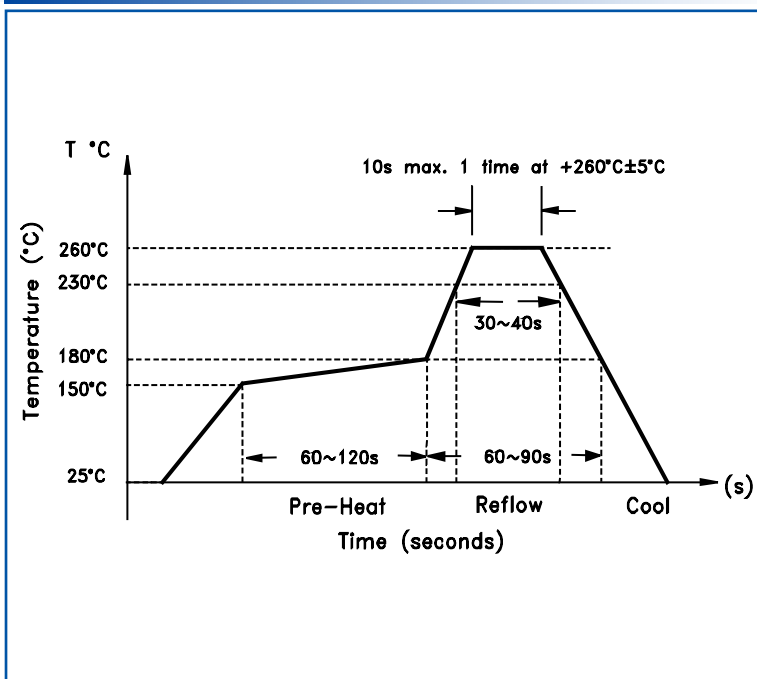

**ATTENTION:** Abracon Corporation's products are COTS – Commercial-Off-The-Shelf products; suitable for Commercial, Industrial and, where designated, Automotive Applications. Abracon's products are not specifically designed for Military, Aviation, Aerospace, Life-dependant Medical applications or any application requiring high reliability where component failure could result in loss of life and/or property. For applications requiring high reliability and/or presenting an extreme operating environment, written consent and authorization from Abracon Corporation is required. Please contact Abracon Corporation for more information.

ABRACON IS  
ISO9001:2008  
CERTIFIED



Visit [www.abracon.com](http://www.abracon.com) for Terms & Conditions of Sale **Revised: 07.08.10**

30332 Esperanza, Rancho Santa Margarita, California 92688

tel 949-546-8000 | fax 949-546-8001 | [www.abracon.com](http://www.abracon.com)