

## MAX16132–MAX16135

## Low-Voltage, Precision, Single/Dual/Triple/ Quad-Voltage $\mu$ P Supervisors

### General Description

The MAX16132–MAX16135 are low-voltage,  $\pm 1\%$  accurate, single, dual, triple, and quad-voltage  $\mu$ P supervisors that monitor up to 4 system-supply voltages for undervoltage and overvoltage faults. The MAX16132–MAX16134 feature independent reset outputs, while the MAX16135 features dual reset outputs. For the MAX16132–MAX16134, a reset output asserts when the voltage at its corresponding input falls outside a factory-trimmed undervoltage and overvoltage window threshold. The reset is maintained for a minimum timeout period after voltage at the input falls within the factory-set window threshold. For the MAX16135, a reset output asserts when either, or both, of the corresponding inputs fall outside the factory-trimmed undervoltage and overvoltage window thresholds. See the [Selector Guide](#) for available options. These integrated supervisory circuits significantly improve system reliability and reduce size compared to separate ICs or discrete components.

The MAX16132–MAX16135 are fixed-threshold devices. The nominal input voltage for any input is factory-programmable from 1.0V to 5.0V, providing a wide range of threshold selections. The window threshold levels are factory-programmable from  $\pm 4\%$  to  $\pm 11\%$ , with  $\pm 1\%$  resolution and 0.25% or 0.50% hysteresis. The  $\pm 1\%$  threshold accuracy over temperature and window threshold monitoring make these devices ideal for automotive ADAS applications.

The reset outputs are active-low, open-drain, and are guaranteed to be in the correct reset output logic state when  $V_{DD}$  remains greater than 1.07V. All devices are offered with 23 reset timeout periods ranging from 20 $\mu$ s (min) to 1200ms (min). All reset outputs share the same factory-set reset timeout period.

The MAX16132–MAX16135 are available in a small 8-pin SOT23 package and specified over the automotive temperature range of  $-40^{\circ}\text{C}$  to  $+125^{\circ}\text{C}$ .

### Applications

- ADAS
- Multivoltage ASICs
- Storage Equipment
- Servers

### Benefits and Features

- High Precision
  - $\pm 1\%$  Threshold Accuracy over Temperature
- Programmable OV Threshold: 104% to 111%
- Programmable UV Threshold: 89% to 96%
- Programmable Input Voltage from 1.0V to 5.0V
- Low 15 $\mu$ A Supply Current
- Quad-Input Monitor
- 23 Programmable Reset Timeout Periods
- Immune to Short Monitored Supply Transients
- Guaranteed Correct Logic State Down to  $V_{DD} = 1.07\text{V}$
- Open-Drain Outputs
- Small SOT23 Package
- $-40^{\circ}\text{C}$  to  $+125^{\circ}\text{C}$  Automotive Operating Temperature Range
- AEC-Q100 Qualified (V Part Numbers, See [Ordering Information](#))

Simplified Block Diagram

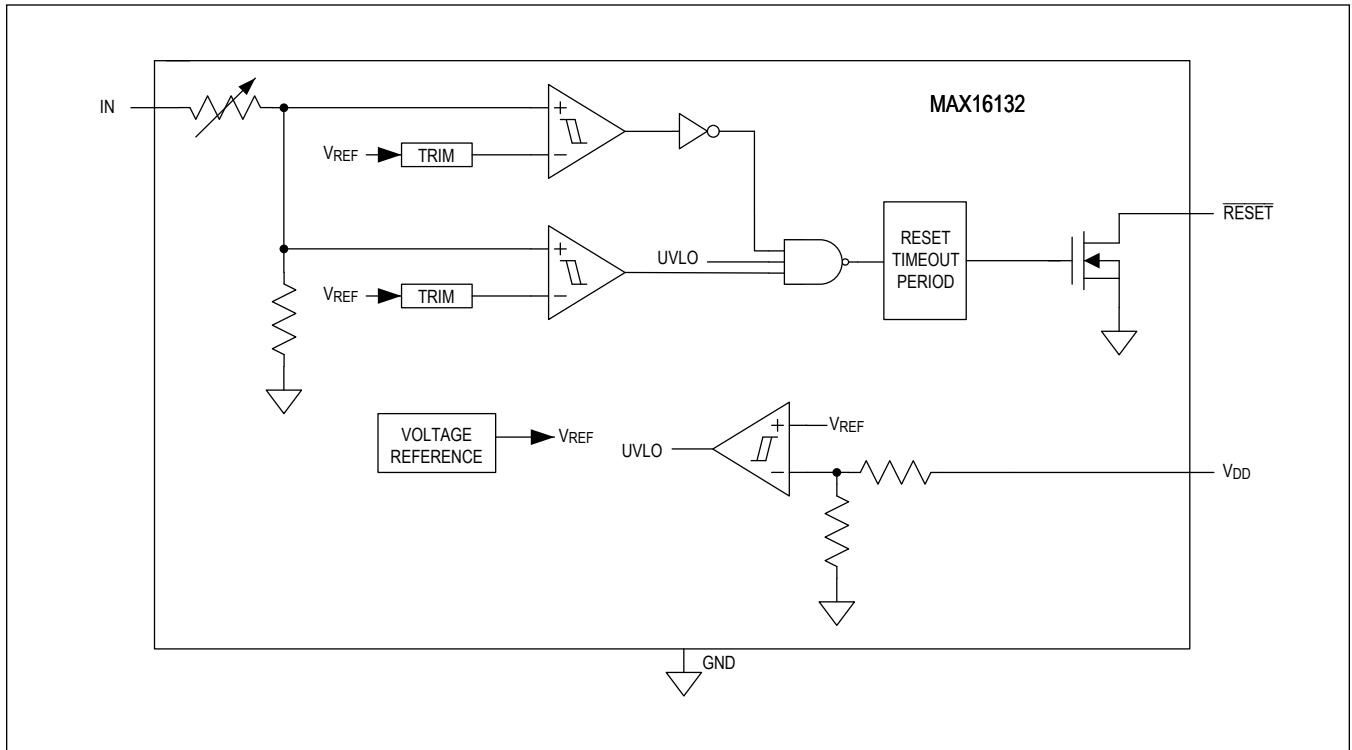

## Absolute Maximum Ratings

$V_{DD}$ to GND.....	-0.3V to +6V	Operating Temperature Range .....	-40°C to +125°C
$V_{IN1}$ , $V_{IN2}$ , $V_{IN3}$ , $V_{IN4}$ to GND .....	-0.3V to +6V	Junction Temperature .....	+150°C
$V_{RESET1}$ , $V_{RESET2}$ , $V_{RESET3}$ to GND .....	-0.3V to +6V	Soldering Temperature (Reflow).....	+260°C
Maximum Input/Output Current (all pins) .....	$\pm 20$ mA	Storage Temperature Range .....	-65°C to +150°C
Continuous Power Dissipation ( $T_A = +70^\circ\text{C}$ ).....	408mW	Lead Temperature .....	+300°C

Stresses beyond those listed under "Absolute Maximum Ratings" may cause permanent damage to the device. These are stress ratings only, and functional operation of the device at these or any other conditions beyond those indicated in the operational sections of the specifications is not implied. Exposure to absolute maximum rating conditions for extended periods may affect device reliability.

## Package Information

### 8 SOT23

[8 SOT23 Package Drawing Link](#)

Package Code	K8+5/K8+5A
Outline Number	<a href="#">21-0078</a>
Land Pattern Number	<a href="#">90-0176</a>
<b>THERMAL RESISTANCE, FOUR-LAYER BOARD</b>	
Junction to Ambient ( $\theta_{JA}$ )	196
Junction to Case ( $\theta_{JC}$ )	70

For the latest package outline information and land patterns (footprints), go to [www.maximintegrated.com/packages](http://www.maximintegrated.com/packages). Note that a "+", "#", or "-" in the package code indicates RoHS status only. Package drawings may show a different suffix character, but the drawing pertains to the package regardless of RoHS status.

Package thermal resistances were obtained using the method described in JEDEC specification JESD51-7, using a four-layer board. For detailed information on package thermal considerations, refer to [www.maximintegrated.com/thermal-tutorial](http://www.maximintegrated.com/thermal-tutorial).

## Electrical Characteristics

( $V_{DD} = 1.71\text{V}$  to  $5.5\text{V}$ ,  $T_A = T_J = -40^\circ\text{C}$  to  $+125^\circ\text{C}$ . Typical values are at  $T_A = +25^\circ\text{C}$ , unless otherwise noted. ([Note 1](#)))

PARAMETER	SYMBOL	CONDITIONS	MIN	TYP	MAX	UNITS
<b>SUPPLY VOLTAGE</b>						
Operating Voltage Range	$V_{DD}$		1.71		5.5	V
Undervoltage-Lockout Threshold	$V_{UVLO}$	$V_{DD}$ rising	1.35	1.50	1.65	V
Undervoltage-Lockout Threshold Hysteresis	$V_{UVLO\_HYS}$	$V_{DD}$ falling		47		mV
<b>SUPPLY CURRENT</b>						
Supply Current	$I_{DD}$	$\overline{\text{RESET}}$ not asserted	5	12.5	30	$\mu\text{A}$
<b>INPUT VOLTAGE</b>						
Nominal Input Voltage Programming Range	$V_{IN\_NOM}$	( <a href="#">Note 2</a> )	1		5.0	V
Tolerance Programming Range	TOL	Reset occurs when $V_{IN\_NOM}$ falls outside of $V_{IN\_NOM} \times (1 \pm \text{TOL}\%)$	4		11	%
Tolerance Programming Resolution	TOL-RES			1		% $V_{IN\_NOM}$

**Electrical Characteristics (continued)**

( $V_{DD} = 1.71V$  to  $5.5V$ ,  $T_A = T_J = -40^\circ C$  to  $+125^\circ C$ . Typical values are at  $T_A = +25^\circ C$ , unless otherwise noted. ([Note 1](#)))

PARAMETER	SYMBOL	CONDITIONS	MIN	TYP	MAX	UNITS
Undervoltage/ Overvoltage Threshold Hysteresis		( <a href="#">Note 3</a> ) ( <a href="#">Note 4</a> )	0.04	0.25	0.47	%
		( <a href="#">Note 3</a> )	0.20	0.50	0.80	
Undervoltage Threshold Accuracy	$V_{UV\_TH\_AC}$	$V_{IN\_NOM}$ falling, $V_{UV\_TH} = V_{IN\_NOM} \times (1 - TOL\%)$	-1	$V_{UV\_TH}$	+1	%
Overvoltage Threshold Accuracy	$OV_{TH\_AC}$	$V_{IN\_NOM}$ rising, $V_{OV\_TH} = V_{IN\_NOM} \times (1 + TOL\%)$	-1	$V_{OV\_TH}$	+1	%
IN_ Input Current	$I_{IN\_}$	$V_{IN\_} = V_{IN\_NOM}$		1.30	2	$\mu A$
<b>RESET OUTPUTS (<a href="#">Note 3</a>)</b>						
Reset Output Voltage Low	$V_{OL}$	$V_{DD} = 5V$ , $I_{SINK} = 3mA$ , $\overline{RESET\_}$ asserted		0.1	0.3	V
		$V_{DD} = 1V$ , $I_{SINK} = 8\mu A$ , $\overline{RESET\_}$ asserted		0.1	0.3	
Reset Output Leakage Current		$V_{\overline{RESET\_}} = 5.5V$ , $T_A = +25^\circ C$		0.001		$\mu A$
		$V_{\overline{RESET\_}} = 5.5V$ , $T_A = +125^\circ C$		0.01	1	
Reset Timeout Period	$t_{RP}$		-40	$t_{RP}$	+30	%
IN_ to $\overline{RESET\_}$ Propagation Delay	$t_D$	$(V_{UV\_TH}+1\%)$ to $(V_{UV\_TH}-1\%)$		15		$\mu s$
		$(V_{OV\_TH}-1\%)$ to $(V_{OV\_TH}+1\%)$		15		

**Note 1:** Devices are tested at  $T_A = +25^\circ C$  and guaranteed by design for  $T_A = -40^\circ C$  to  $+125^\circ C$ .

**Note 2:** The sum of nominal input voltage, tolerance percentage, and threshold accuracy percentage must not exceed 5.5V.

**Note 3:** Contact factory for the desired option.

**Note 4:** Guaranteed by characterization.

Typical Operating Characteristics

( $V_{DD} = 5V$ ,  $T_A = +25^\circ C$ , unless otherwise noted.)

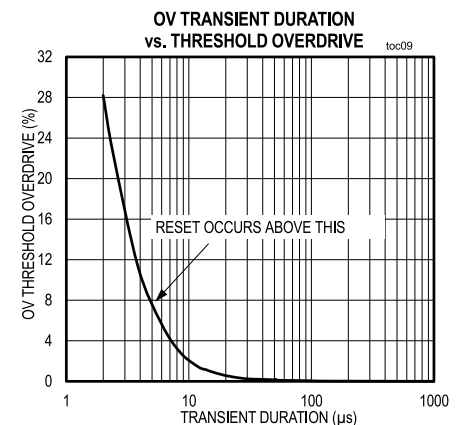
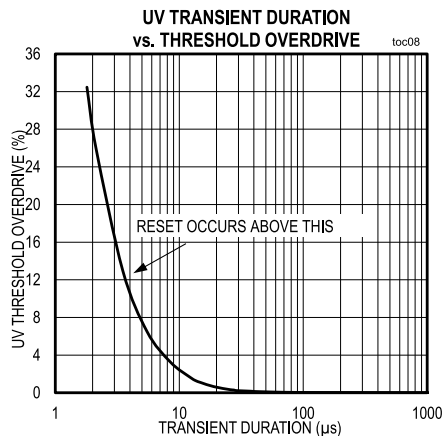
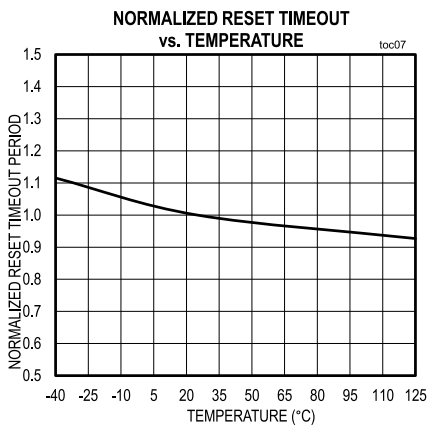
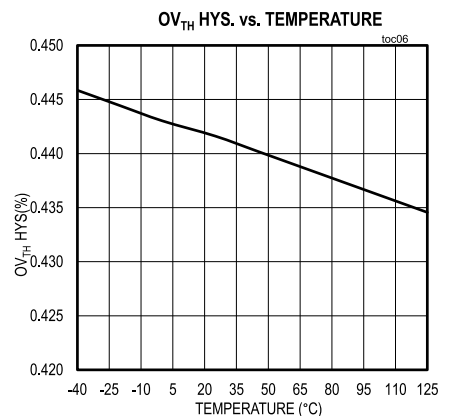
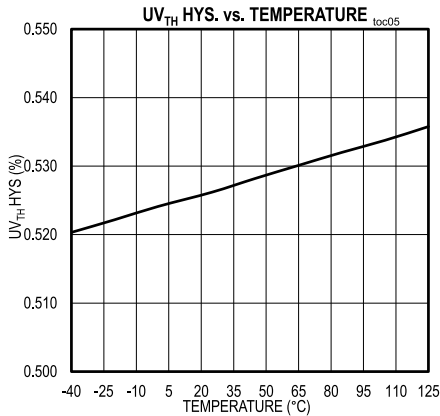
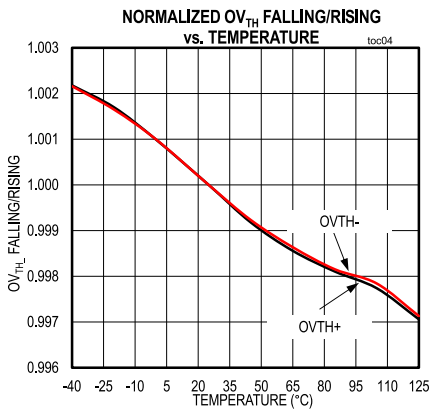
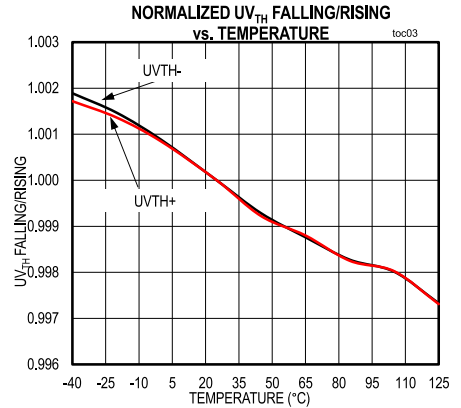
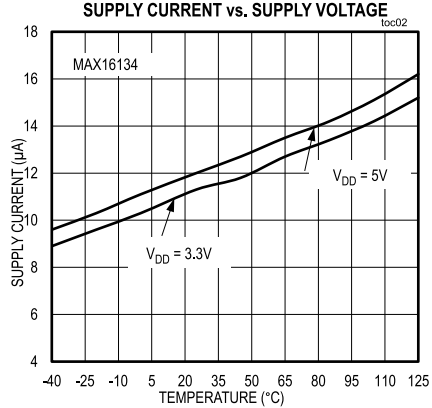
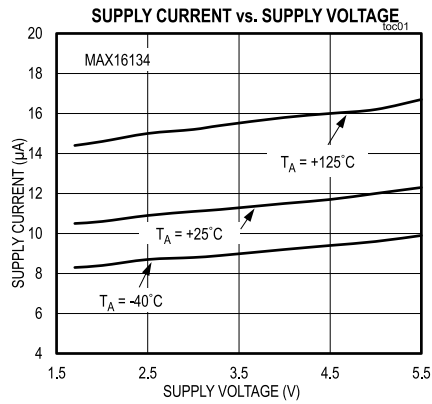

**Typical Operating Characteristics (continued)**

( $V_{DD} = 5V$ ,  $T_A = +25^\circ C$ , unless otherwise noted.)

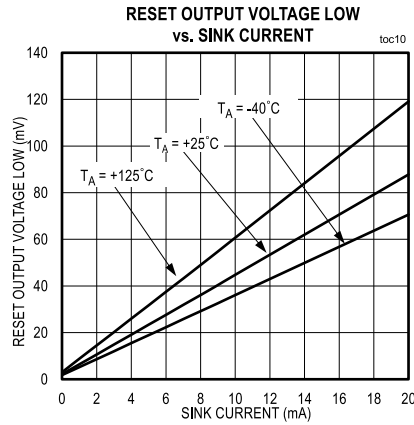

**Pin Configurations**

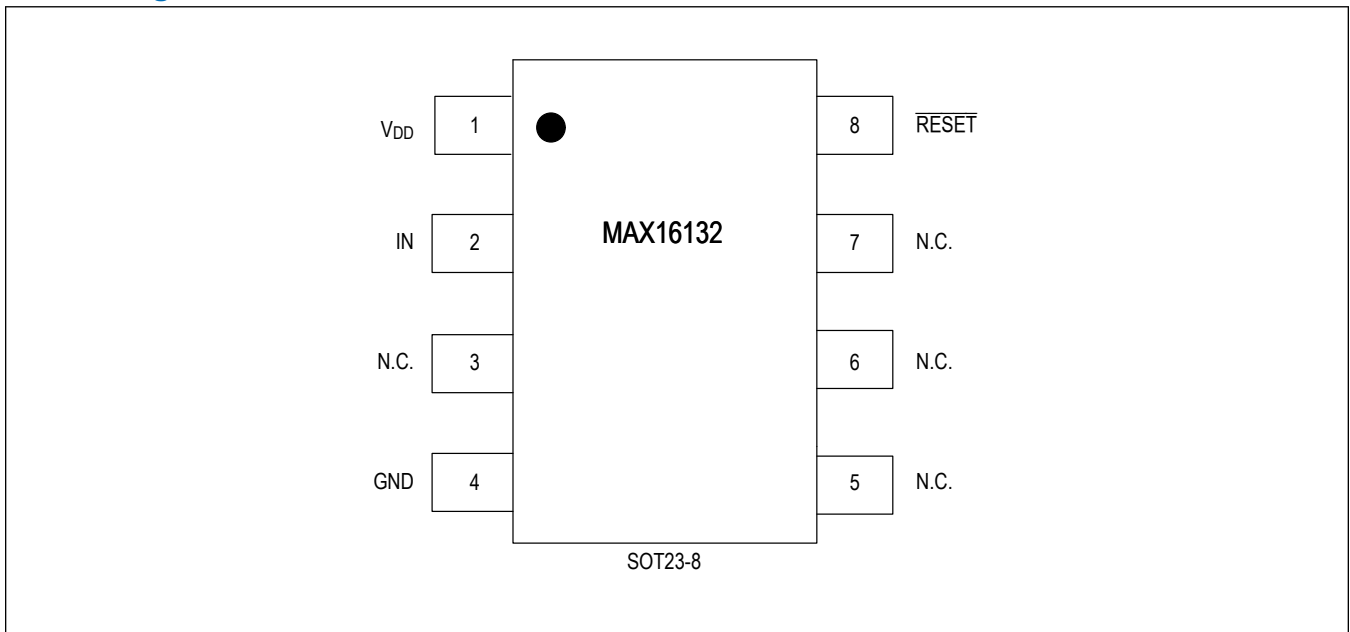

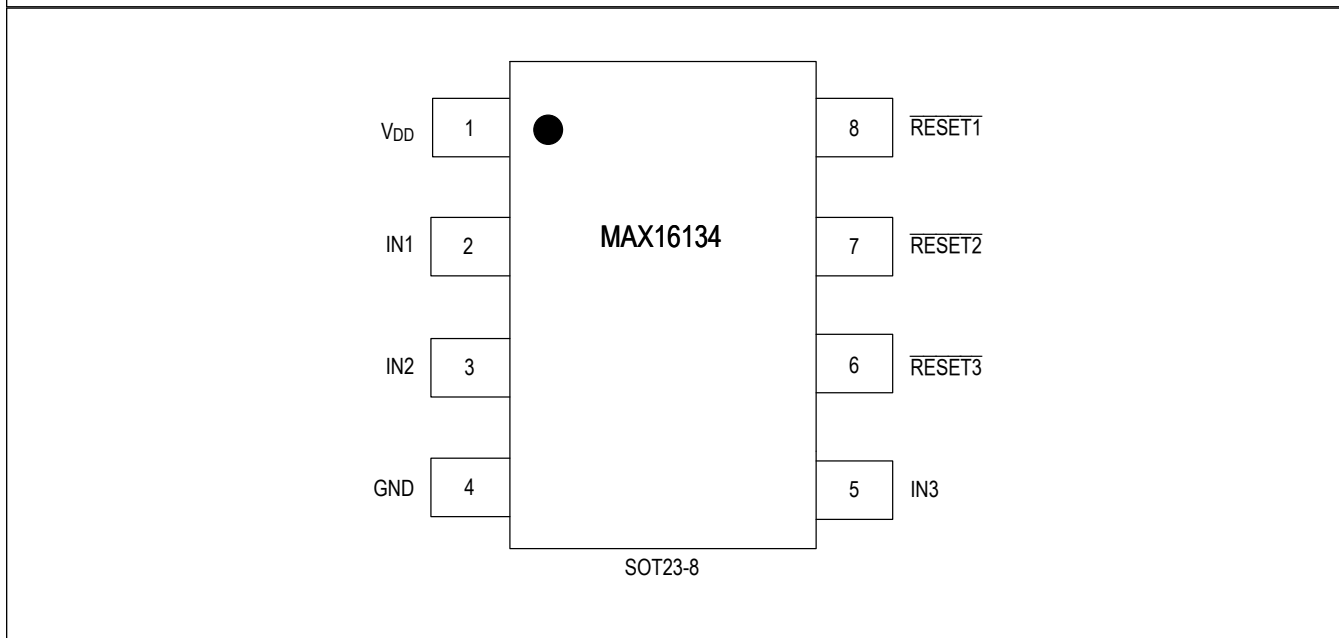
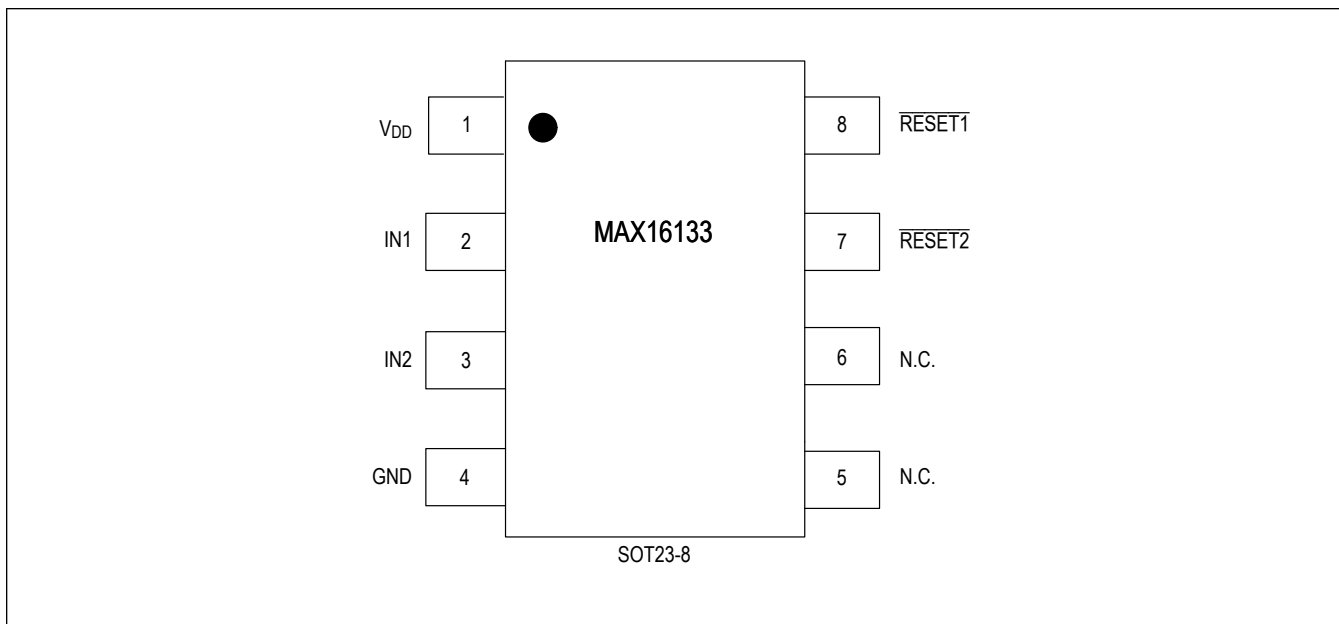

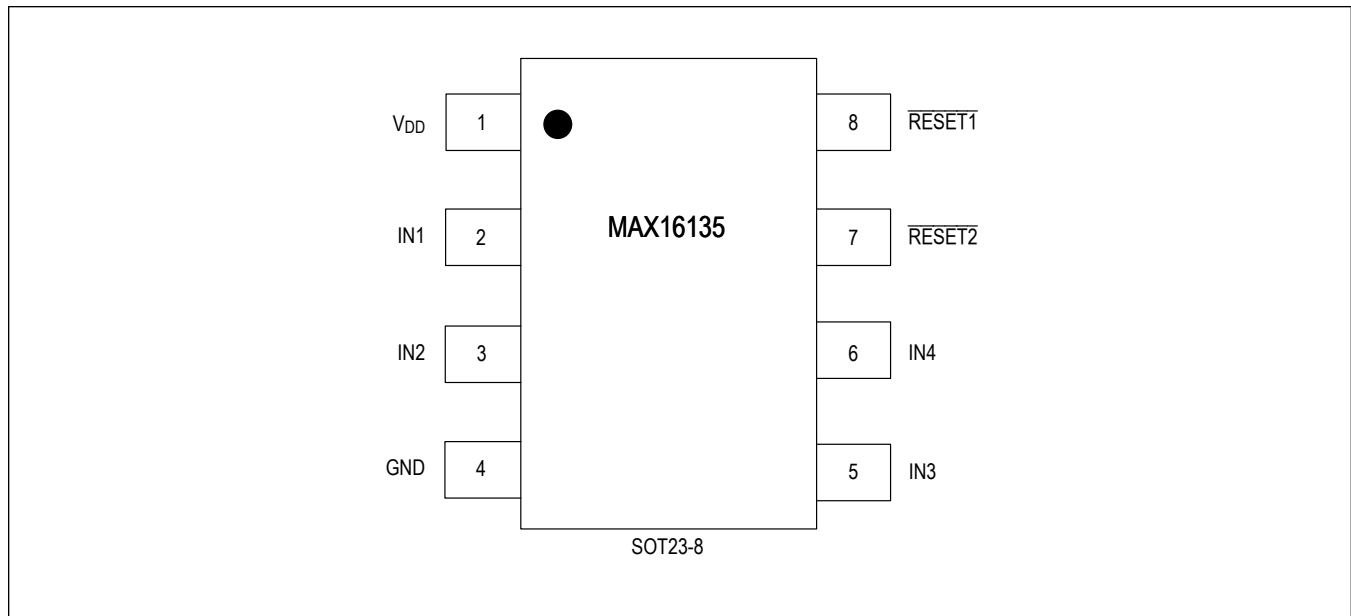

## Pin Description

PIN				NAME	FUNCTION
MAX16132	MAX16133	MAX16134	MAX16135		
1	1	1	1	$V_{DD}$	Supply Input. Bypass with a 0.1 $\mu$ F capacitor to GND.
2	—	—	—	IN	Monitoring Input. Connect IN to its nominal input voltage. When $V_{IN}$ falls outside overvoltage/undervoltage window threshold, RESET asserts.
3, 5, 6, 7	5, 6	—	—	N.C.	No Connect. Connect to ground.
4	4	4	4	GND	Ground
8	—	—	—	$\overline{\text{RESET}}$	Active-Low, Open-Drain Reset Output. $\overline{\text{RESET}}$ asserts when $V_{IN}$ falls outside of the undervoltage/overvoltage window threshold. RESET stays asserted for the reset timeout period after $V_{IN}$ fall within the undervoltage/overvoltage window threshold. RESET requires a pullup resistor.
—	2	2	2	IN1	Monitoring Input 1. Connect IN1 to its nominal input voltage. When $V_{IN1}$ falls outside the undervoltage/overvoltage window threshold, RESET1 asserts. For the quad input, (MAX16135), RESET1 asserts when either IN1 and/or IN2 falls outside the undervoltage/overvoltage window threshold.
—	3	3	3	IN2	Monitoring Input 2. Connect IN2 to its nominal input voltage. When $V_{IN2}$ falls outside the undervoltage/overvoltage window threshold, RESET2 asserts. For the quad input (MAX16135), RESET1 asserts when either IN2 and/or IN1 falls outside the undervoltage/overvoltage window threshold.



## Pin Description (continued)

PIN				NAME	FUNCTION
MAX16132	MAX16133	MAX16134	MAX16135		
—	7	7	7	$\overline{\text{RESET2}}$	Active-Low, Open-Drain Reset Output 2. $\overline{\text{RESET2}}$ asserts when $V_{\text{IN2}}$ falls outside the undervoltage/overvoltage window threshold. $\overline{\text{RESET2}}$ stays asserted for the reset timeout period after $V_{\text{IN2}}$ falls within the undervoltage/overvoltage window threshold. $\overline{\text{RESET2}}$ requires a pullup resistor. For the MAX16135, $\overline{\text{RESET2}}$ asserts when either IN3 and/or IN4 falls outside the undervoltage/overvoltage window threshold.
—	8	8	8	$\overline{\text{RESET1}}$	Active-Low, Open-Drain Reset Output 1. $\overline{\text{RESET1}}$ asserts when $V_{\text{IN1}}$ falls outside the undervoltage/overvoltage window threshold. $\overline{\text{RESET1}}$ stays asserted for the reset timeout period after $V_{\text{IN1}}$ falls within the undervoltage/overvoltage window threshold. $\overline{\text{RESET1}}$ requires a pullup resistor. For the MAX16135, $\overline{\text{RESET1}}$ asserts when either IN1 and/or IN2 falls outside the undervoltage/overvoltage window threshold.
—	—	5	5	IN3	Monitoring Input 3. Connect IN3 to its nominal input voltage. When $V_{\text{IN3}}$ falls outside overvoltage/undervoltage window threshold, $\overline{\text{RESET3}}$ asserts. For the MAX16135, $\overline{\text{RESET2}}$ asserts when either IN3 and/or IN4 falls outside the undervoltage/overvoltage window threshold.
—	—	6	—	$\overline{\text{RESET3}}$	Active-Low, Open-Drain Reset Output 3. $\overline{\text{RESET3}}$ asserts when $V_{\text{IN3}}$ falls outside the undervoltage/overvoltage window threshold. $\overline{\text{RESET3}}$ stays asserted for the reset timeout period after the $V_{\text{IN3}}$ falls within the undervoltage/overvoltage window threshold. $\overline{\text{RESET3}}$ requires a pullup resistor.
—	—	—	6	IN4	Monitoring Input 4. Connect IN4 to its nominal input voltage. When $V_{\text{IN4}}$ falls outside the overvoltage/undervoltage window threshold, $\overline{\text{RESET2}}$ asserts, $\overline{\text{RESET2}}$ asserts when either IN4 and/or IN3 falls outside the undervoltage/overvoltage window threshold.

### Functional Diagrams

#### Single-Input Functional Block Diagram

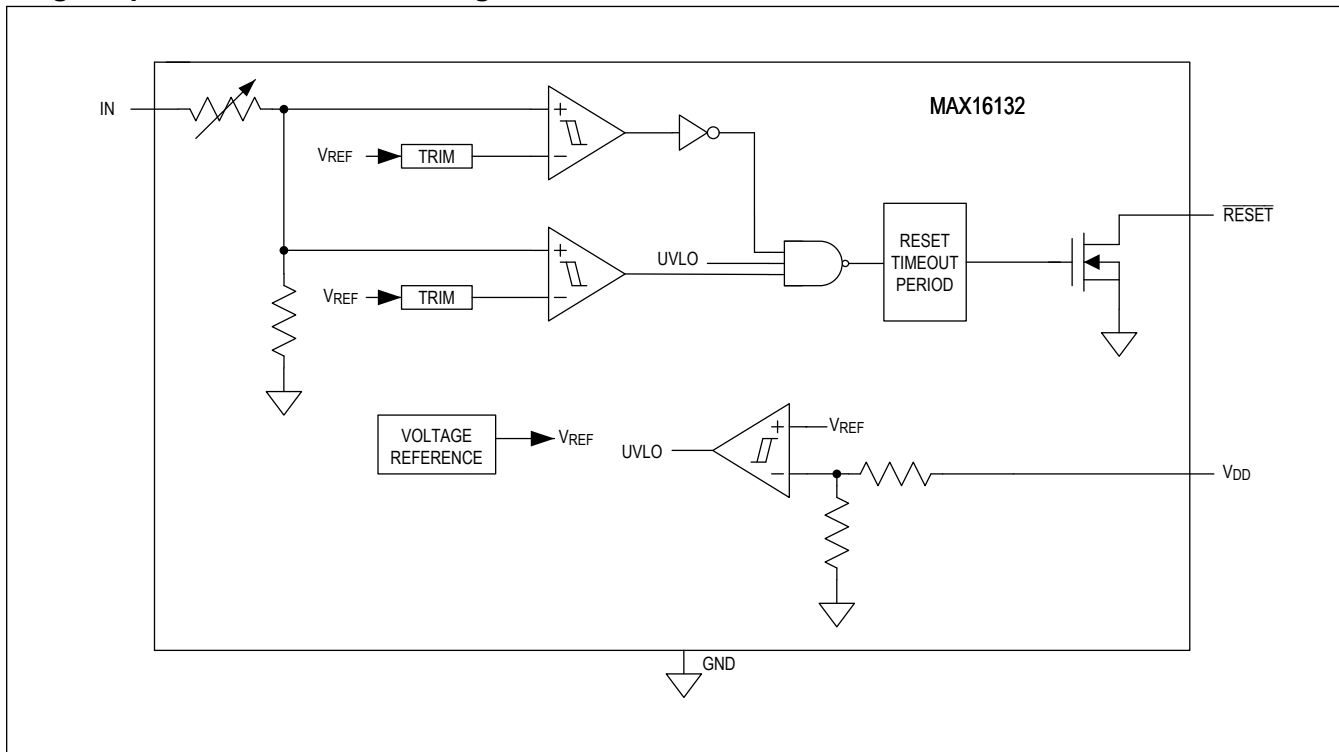

Dual-Input Functional Block Diagram

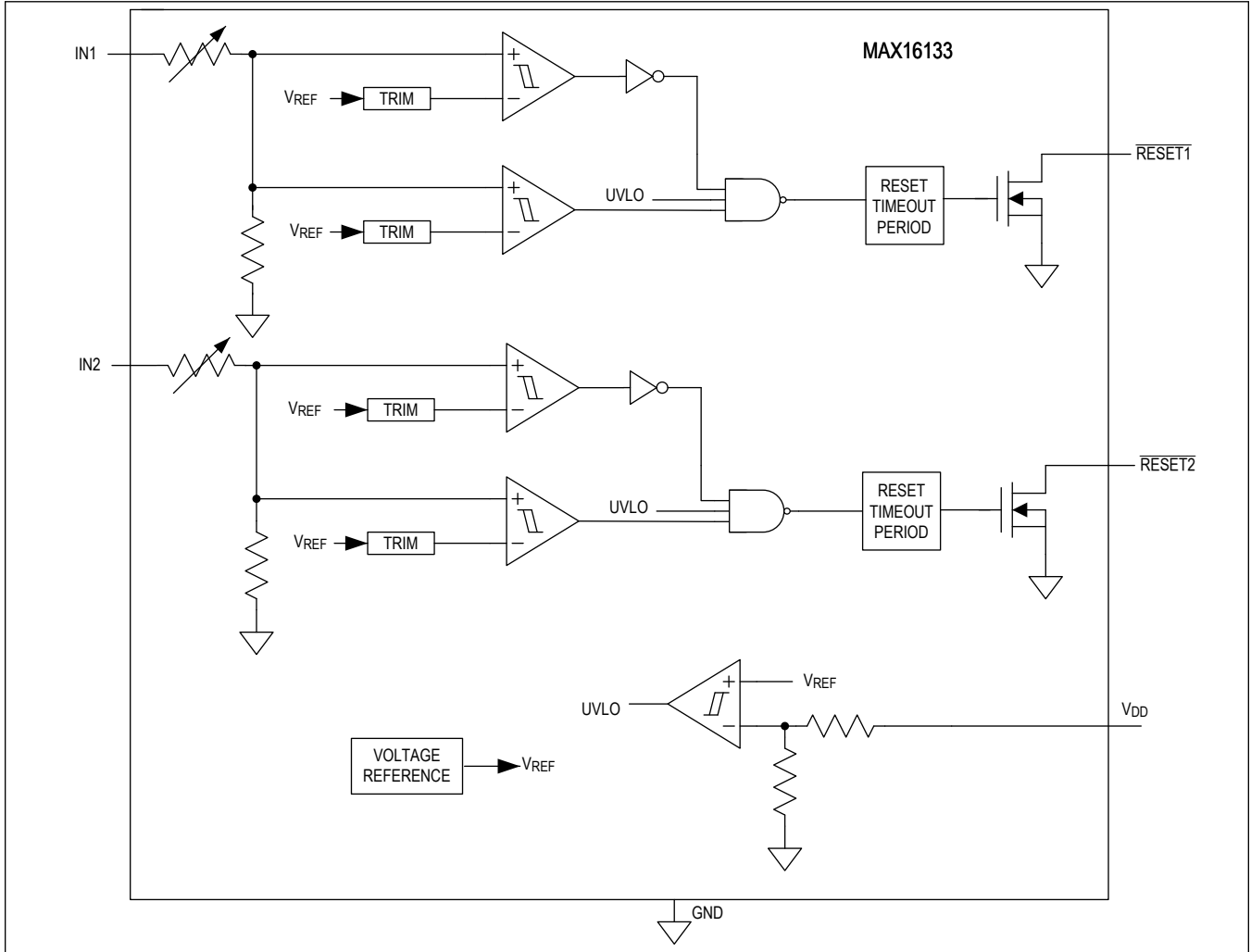

**Triple-Input Functional Block Diagram**

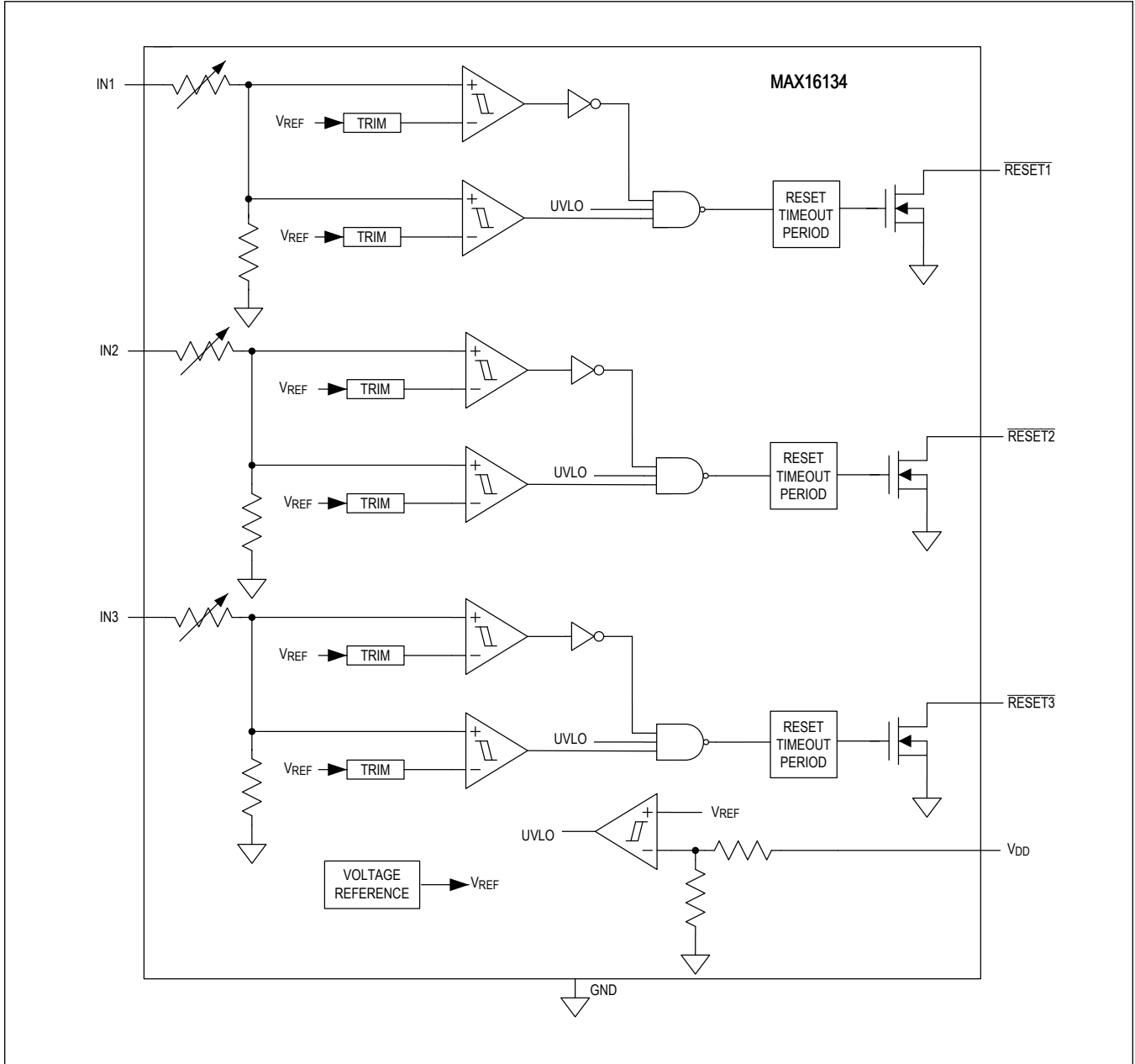

Quad-Input Functional Block Diagram

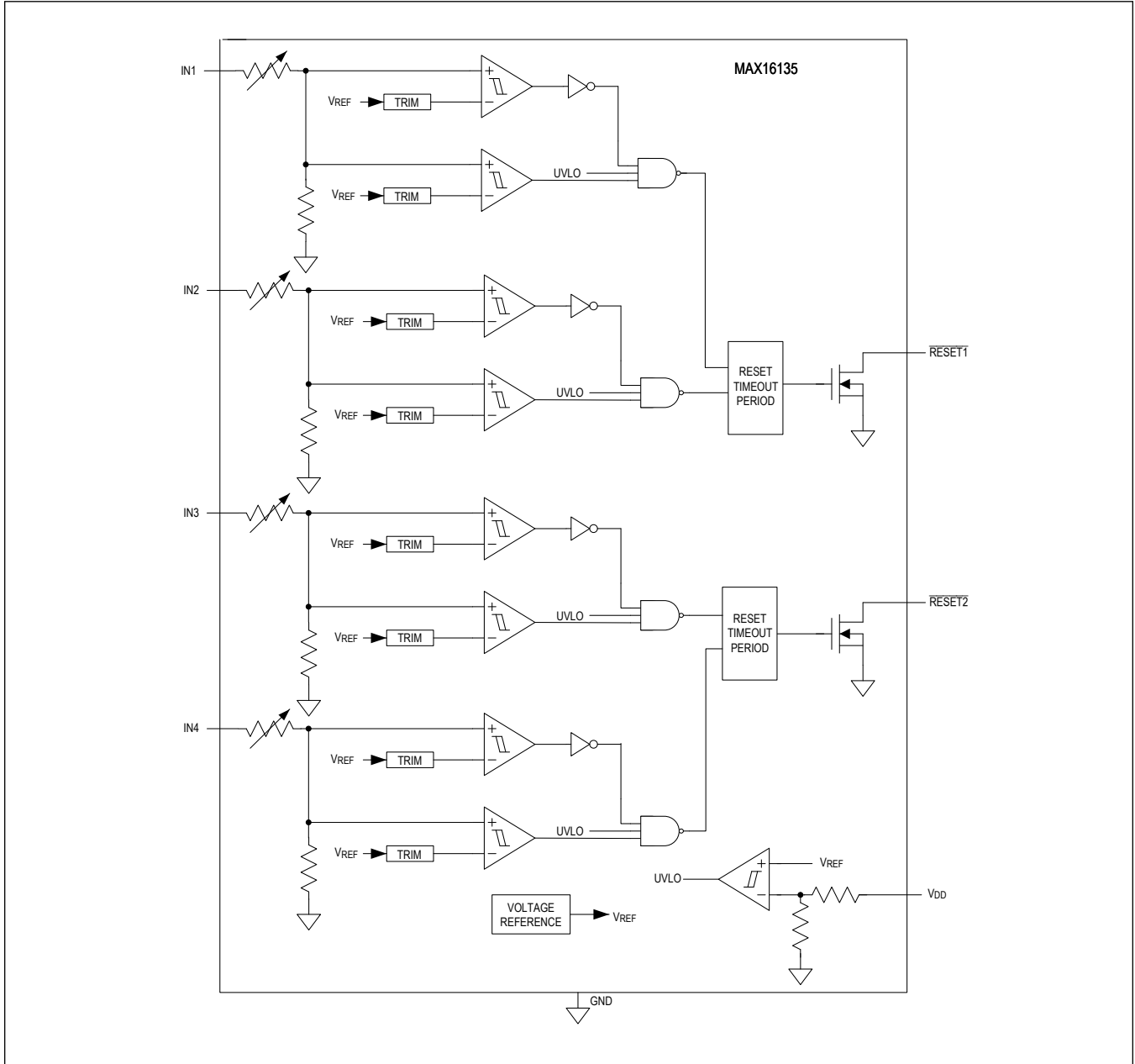

## Detailed Description

### Detailed Description

The MAX16132–MAX16135 are single, dual, triple, and quad-voltage  $\mu$ P supervisors designed to maintain system integrity in multi-supply systems. These devices offer undervoltage and overvoltage window threshold monitoring within  $\pm 1\%$  accuracy over temperature.

### Input Voltage

The MAX16132–MAX16135 feature factory-programmable input-voltage-level options from 1.0V to 5V. See [Table 1](#) thru [Table 4](#), as well as the [Selector Guide](#) for standard voltage options. The selection of nominal input voltage does not set the voltage threshold levels. For the MAX16132–MAX16135, the undervoltage and overvoltage thresholds are determined by the selection of input tolerance. See the [Electrical Characteristics](#) table and [Input Tolerance/Hysteresis](#) section for more detail.

### Input Tolerance/Hysteresis

The MAX16132–MAX16135 are designed to offer eight factory-programmable input tolerance levels from  $\pm 4\%$  to  $\pm 11\%$  in  $\pm 1\%$  increment. The input tolerance level sets the undervoltage and overvoltage threshold levels with respect to the selected nominal input voltage. See [Table 5](#) thru [Table 8](#) for hysteresis and tolerance values.

The MAX16132–MAX16135 are immune to short  $IN_{\_}$  transients. Each of the internal comparators are factory-set to either 0.5% or 0.25% hysteresis with respect to the selected nominal input voltage. Hysteresis provides input immunity to ambient noise without significantly reducing the input threshold accuracy. See the *Maximum  $IN_{\_}$  Transient Duration vs. Reset Threshold Overdrive* graph in the [Typical Operating Characteristics](#) section.

### Reset Outputs

The MAX16132–MAX16134 feature independent, active-low, open-drain reset outputs, while the MAX16135 features dual reset outputs. For the MAX16132–MAX16134, when an input voltage falls outside the set window threshold, the corresponding reset outputs asserts. The reset output deasserts after the reset timeout period when the input voltage falls within the window threshold. See [Figure 1](#) below for more detail.

The MAX16135 feature dual reset outputs.  $\overline{RESET1}$  asserts when  $V_{IN1}$  and/or  $V_{IN2}$  falls outside the set window threshold.  $\overline{RESET2}$  asserts when  $V_{IN3}$  and/or  $V_{IN4}$  falls outside the set window threshold.  $\overline{RESET1}$  and  $\overline{RESET2}$  deassert after the reset timeout period when their corresponding input voltages are within the set window threshold. At power-up, resets stay asserted for the reset timeout period once  $V_{DD}$  is above the UVLO. All reset outputs require a pullup resistor to  $V_{DD}$ .

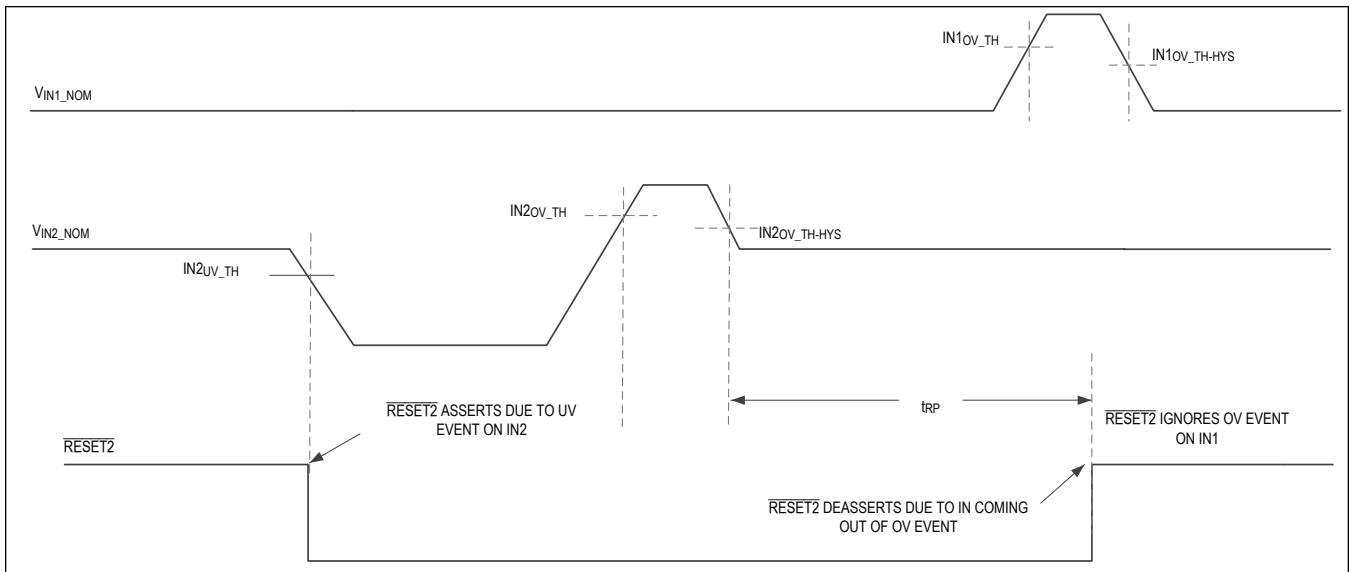

Figure 1. Independent Reset Output Timing Diagram (MAX16133/MAX16134)

### Reset Timeout Period

The MAX16132–MAX16135 offer 23 factory-set reset timeout periods. All reset outputs share the same reset timeout period. See [Table 9](#) for reset timeout period selection.

### Configuration Tables

**Table 1. Single-Input Nominal Voltage Options (Typ)**

SUFFIX	IN_NOM (V)	SUFFIX	IN_NOM (V)
—	—	28	2.800
—	—	29	2.900
—	—	30	3.000
—	—	31	3.100
—	—	32	3.200
04	1.240	—	—
10	1.00	33	3.300
11	1.100	34	3.400
12	1.200	35	3.500
13	1.300	36	3.600
14	1.400	37	3.700
15	1.500	38	3.800
16	1.600	39	3.900
17	1.700	40	4.000
18	1.800	41	4.100
19	1.900	42	4.200
20	2.000	43	4.300
21	2.100	44	4.400
22	2.200	45	4.500

**Table 1. Single-Input Nominal Voltage Options (Typ) (continued)**

SUFFIX	IN_NOM (V)	SUFFIX	IN_NOM (V)
23	2.300	46	4.600
24	2.400	47	4.700
25	2.500	48	4.800
26	2.600	49	4.900
27	2.700	50	5.000

**Table 2. Dual-Input Nominal Voltage Options (Typ)**

SUFFIX	IN1_NOM (V)	IN2_NOM (V)
A	5.000	3.300
B	5.000	1.800
C	5.000	1.200
D	5.000	1.000
E	3.300	1.800
F	3.300	1.200
G	3.300	1.000
H	2.500	1.200
I	2.500	1.160
J	1.800	1.500
K	1.800	1.200
L	1.800	1.000
M	1.500	1.200
N	1.500	1.000
O	1.200	1.000
P	2.500	1.140
Q	1.25	1.25

**Table 3. Triple-Input Nominal Voltage Options (Typ)**

SUFFIX	IN1_NOM (V)	IN2_NOM (V)	IN3_NOM (V)
A	5.000	3.300	1.800
B	5.000	3.300	1.200
C	5.000	3.300	1.000
D	4.800	3.000	1.800
E	4.800	3.000	1.200
F	4.800	1.800	1.200
G	4.800	1.800	1.000
H	4.500	3.300	1.800
I	4.500	3.300	1.200
J	4.500	3.300	1.000
K	3.300	1.800	1.200
L	3.300	1.800	1.000
M	3.000	1.800	1.200
N	3.000	1.800	1.000



**Table 3. Triple-Input Nominal Voltage Options (Typ) (continued)**

SUFFIX	IN1_NOM (V)	IN2_NOM (V)	IN3_NOM (V)
O	2.500	1.800	1.200
P	2.500	1.800	1.000
Q	3.30	2.50	1.160

**Table 4. Quad-Input Nominal Voltage Options (Typ)**

SUFFIX	IN1_NOM (V)	IN2_NOM (V)	IN3_NOM (V)	IN4_NOM (V)
A	5.000	3.300	2.500	1.500
B	5.000	3.300	1.800	1.200
C	5.000	3.300	1.200	1.000
D	4.800	3.300	1.800	1.200
E	4.800	2.500	1.800	1.200
F	4.800	3.00	1.500	1.000
G	4.500	3.300	2.500	1.800
H	4.500	3.000	1.800	1.200
I	3.300	2.500	1.800	1.500
J	3.300	2.500	1.800	1.200
K	3.300	1.800	1.200	1.000
L	3.000	2.500	1.500	1.200
M	3.000	1.800	1.200	1.000
N	2.500	1.800	1.200	1.000
O	2.300	1.800	1.500	1.200
P	2.300	1.500	1.200	1.000
Q	3.300	1.800	1.160	1.160
R	5.000	3.240	1.220	1.800
S	1.800	1.500	1.360	1.200
T	3.300	1.000	1.000	3.300

**Table 5. Single-Input HYS/TOL Options (Typ)**

SUFFIX	IN HYS (%) / TOL ( $\pm$ %)
A	0.5/4
B	0.25/4
C	0.5/5
D	0.25/5
E	0.5/6
F	0.25/6
G	0.5/7
H	0.25/7
I	0.5/8
J	0.25/8
K	0.5/9
L	0.25/9
M	0.5/10

**Table 5. Single-Input HYS/TOL Options (Typ) (continued)**

SUFFIX	IN HYS (%) / TOL ( $\pm$ %)
N	0.25/10
O	0.5/11
P	0.25/11

**Table 6. Dual-Input HYS/TOL Options (Typ)**

SUFFIX	IN1 HYS (%) / TOL ( $\pm$ %)	IN2 HYS (%) / TOL ( $\pm$ %)
A	0.5/4	0.5/4
B	0.25/4	0.25/4
C	0.5/5	0.5/5
D	0.25/5	0.25/5
E	0.5/6	0.5/6
F	0.25/6	0.25/6
G	0.5/7	0.5/7
H	0.25/7	0.25/7
I	0.5/8	0.5/8
J	0.25/8	0.25/8
K	0.5/9	0.5/9
L	0.25/9	0.25/9
M	0.5/10	0.5/10
N	0.25/10	0.25/10
O	0.5/11	0.5/11
P	0.25/11	0.25/11

**Table 7. Triple-Input HYS/TOL Options (Typ)**

SUFFIX	IN1 HYS (%) / TOL ( $\pm$ %)	IN2 HYS (%) / TOL ( $\pm$ %)	IN3 HYS (%) / TOL ( $\pm$ %)
A	0.5/4	0.5/4	0.5/4
B	0.25/4	0.25/4	0.25/4
C	0.5/5	0.5/5	0.5/5
D	0.25/5	0.25/5	0.25/5
E	0.5/6	0.5/6	0.5/6
F	0.25/6	0.25/6	0.25/6
G	0.5/7	0.5/7	0.5/7
H	0.25/7	0.25/7	0.25/7
I	0.5/8	0.5/8	0.5/8
J	0.25/8	0.25/8	0.25/8
K	0.5/9	0.5/9	0.5/9
L	0.25/9	0.25/9	0.25/9
M	0.5/10	0.5/10	0.5/10
N	0.25/10	0.25/10	0.25/10
O	0.5/11	0.5/11	0.5/11
P	0.25/11	0.25/11	0.25/11
Q	0.25/4	0.25/4	0.25/7

**Table 8. Quad-Input HYS/TOL Options (Typ)**

SUFFIX	IN1 HYS (%) / TOL ( $\pm$ %)	IN2 HYS (%) / TOL ( $\pm$ %)	IN3 HYS (%) / TOL ( $\pm$ %)	IN4 HYS (%) / TOL ( $\pm$ %)
A	0.5/4	0.5/4	0.5/4	0.5/4
B	0.25/4	0.25/4	0.25/4	0.25/4
C	0.5/5	0.5/5	0.5/5	0.5/5
D	0.25/5	0.25/5	0.25/5	0.25/5
E	0.5/6	0.5/6	0.5/6	0.5/6
F	0.25/6	0.25/6	0.25/6	0.25/6
G	0.5/7	0.5/7	0.5/7	0.5/7
H	0.25/7	0.25/7	0.25/7	0.25/7
I	0.5/8	0.5/8	0.5/8	0.5/8
J	0.25/8	0.25/8	0.25/8	0.25/8
K	0.5/9	0.5/9	0.5/9	0.5/9
L	0.25/9	0.25/9	0.25/9	0.25/9
M	0.5/10	0.5/10	0.5/10	0.5/10
N	0.25/10	0.25/10	0.25/10	0.25/10
O	0.5/11	0.5/11	0.5/11	0.5/11
P	0.25/11	0.25/11	0.25/11	0.25/11
Q	0.25/11	0.25/4	0.5/11	0.5/4
R	0.25/8	0.25/5	0.25/5	0.25/4
S	0.5/8	0.5/4	0.5/6	0.5/6

**Table 9. Reset Timeout (Min)**

SUFFIX	TRP	SUFFIX	TRP
A	20 $\mu$ s	M	70ms
B	1ms	N	100ms
C	2ms	O	140ms
D	3ms	P	150ms
E	5ms	Q	200ms
F	10ms	R	280ms
G	15ms	S	400ms
H	20ms	T	560ms
I	25ms	U	800ms
J	35ms	V	1120ms
K	40ms	W	1200ms
L	50ms	—	—

## Applications Information

### Unused Inputs

The MAX16132–MAX16135 are capable of monitoring inputs for undervoltage and overvoltage events within a very narrow voltage window. Connect any unused IN\_ input to its nominal voltage setting.

### Setting Input Thresholds

The MAX16132–MAX16135 reset devices that monitor input within a window threshold set by the input tolerance selection. Tolerance setting determines the boundary for undervoltage and overvoltage thresholds. The selected nominal input voltage must stay within the window threshold for the MAX16132–MAX16135 not to issue a reset signal. See below for threshold calculation for 2.5V nominal input voltage and  $\pm 10\%$  input tolerance:

$$V_{INNOM} = 2.5V$$

$$TOL = \pm 10\%$$

$$V_{UVTH} = V_{INNOM}(1 - 10\%) = 2.5V(1 - 0.1) = 2.5V - 0.250V = 2.250V$$

$$V_{OVTH} = V_{INNOM}(1 + 10\%) = 2.5V(1 + 0.1) = 2.5V + 0.250V = 2.750V$$

Where  $V_{INNOM}$  is the selected nominal input voltage,  $TOL$  is the input tolerance,  $V_{UVTH}$  is undervoltage threshold voltage and  $V_{OVTH}$  is the overvoltage threshold voltage.

The MAX16132–MAX16135 feature  $\pm 1\%$  threshold accuracy over temperature. This excursion must be added to the calculated undervoltage and overvoltage threshold settings to account for the threshold variation as shown below:

$$V_{UVTH\_EXC} = V_{UVTH}(1 \pm 1\%) = 2.250V(1 \pm 0.01) = 2.250V \pm 0.0225V$$

$$V_{OVTH\_EXC} = V_{OVTH}(1 \pm 1\%) = 2.750V(1 \pm 0.01) = 2.750V \pm 0.0275V$$

Where  $V_{UVTH\_EXC}$  is the undervoltage threshold variation and  $V_{OVTH\_EXC}$  is the overvoltage threshold variation.

### Undervoltage/Overvoltage-Detection Circuit

The open-drain outputs of the MAX16132–MAX16135 can be configured to detect an undervoltage/overvoltage condition. [Figure 2](#) shows the MAX16132 reset output deriving an LED when there is an overvoltage/undervoltage event on IN.

**Note:** The value for the current-limiting resistor R must be chosen such that it does not violate the absolute maximum ratings of the reset pin.

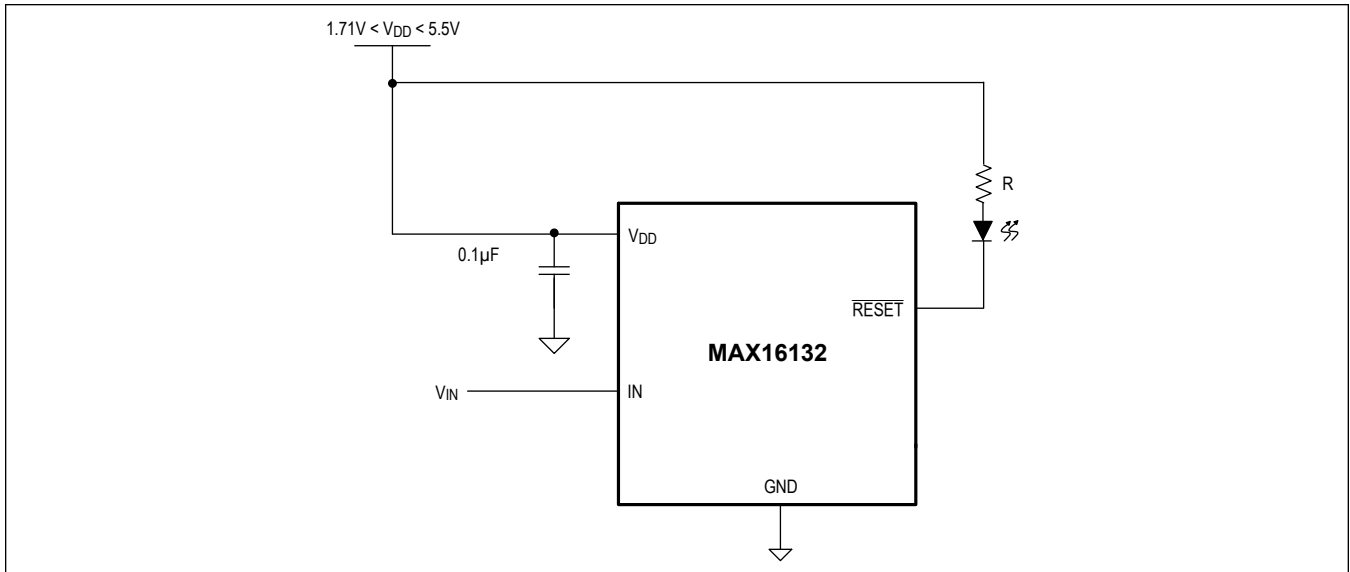

Figure 2. Undervoltage/Overvoltage Detection Circuit with LED Indicator

**Power-Supply Bypassing and Grounding**

The MAX16132–MAX16135 operate from a 1.71V to 5.5V supply. An undervoltage lockout ensures that the outputs are in the correct states when the UVLO is exceeded. Bypass  $V_{DD}$  to ground with a  $0.1\mu F$  capacitor as close to the device as possible. Additional capacitor improves transient immunity. For fast transients with large voltage excursion, a filter resistor in series with the bypass capacitor is recommended for proper device operation. See [Figure 3](#) below for more detail.

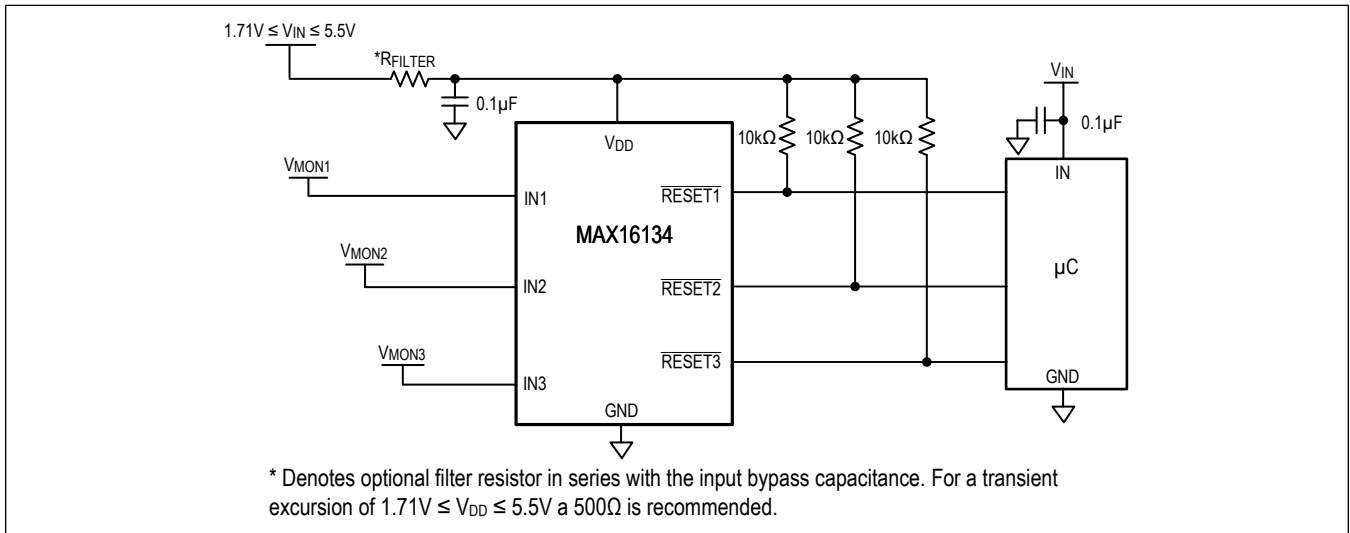
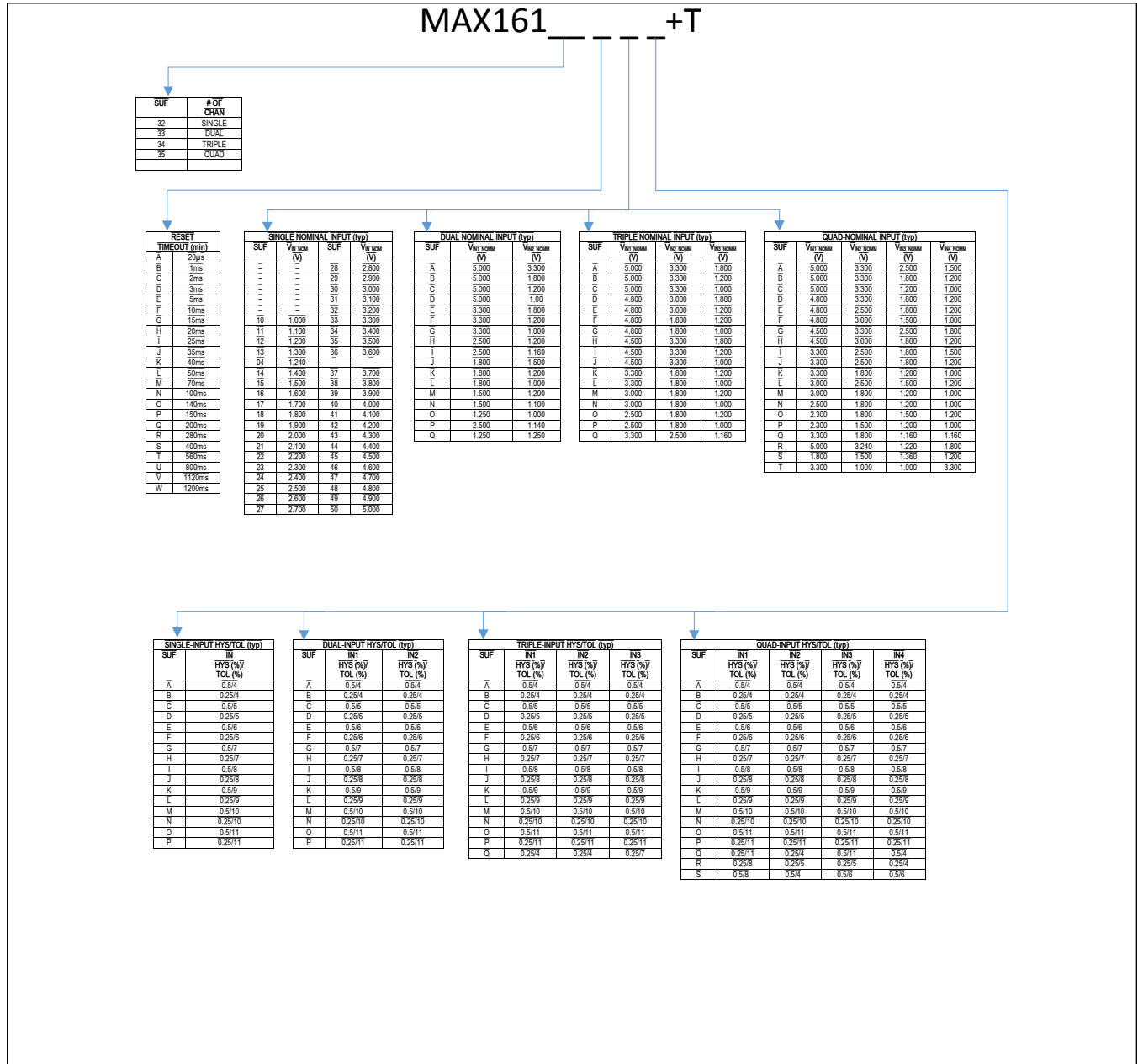
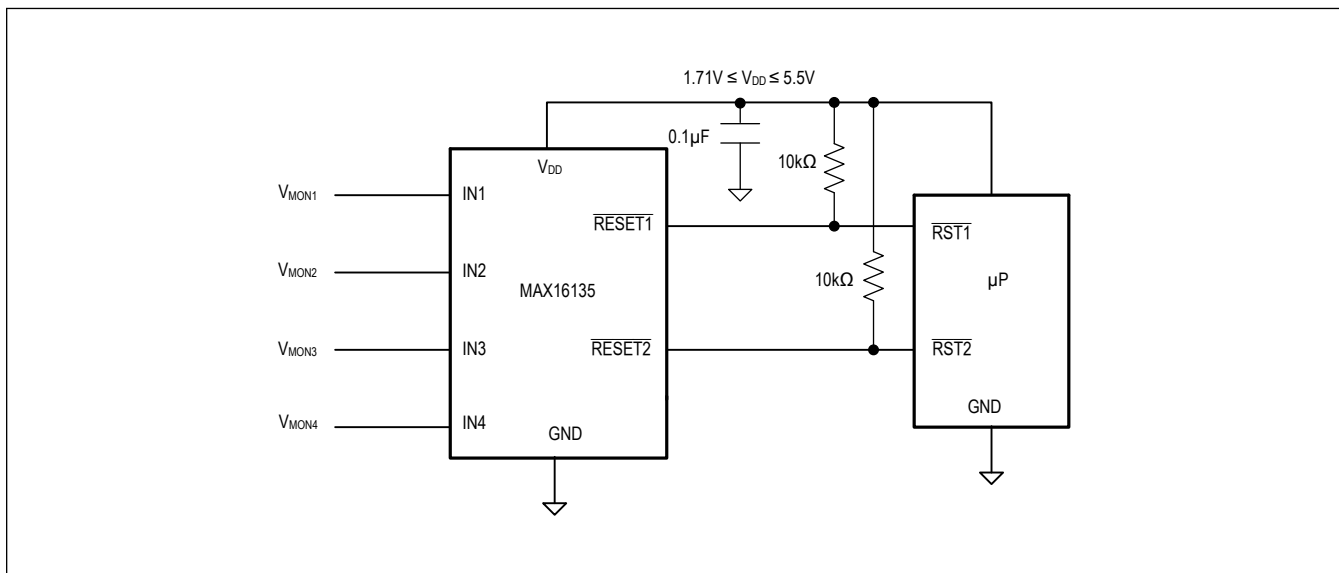

Figure 3. Power Supply Bypassing/Input Filter

Selector Guide



Typical Operating Circuit



## Ordering Information

PART NUMBER	TEMP RANGE	PIN-PACKAGE
<b>MAX16132</b> B11A/V+T	-40°C to +125°C	8 SOT23
MAX16132B33A+T	-40°C to +125°C	8 SOT23
MAX16132B33F/V+T	-40°C to +125°C	8 SOT23
MAX16132E33B/V+T	-40°C to +125°C	8 SOT23
MAX16132F04E/V+T	-40°C to +125°C	8 SOT23
MAX16132F33G/V+T	-40°C to +125°C	8 SOT23
MAX16132G04D+T	-40°C to +125°C	8 SOT23
MAX16132G04D/V+T	-40°C to +125°C	8 SOT23
MAX16132H10B+T	-40°C to +125°C	8 SOT23
MAX16132H10B/V+T	-40°C to +125°C	8 SOT23
MAX16133AEG/V+T	-40°C to +125°C	8 SOT23
<b>MAX16133</b> BFM+T	-40°C to +125°C	8 SOT23
MAX16133BFM/V+T	-40°C to +125°C	8 SOT23
MAX16133BHA+T	-40°C to +125°C	8 SOT23
MAX16133EEM/V+T	-40°C to +125°C	8 SOT23
MAX16133FQP/V+T	-40°C to +125°C	8 SOT23
MAX16133HPB/V+	-40°C to +125°C	8 SOT23
MAX16133HPB+T	-40°C to +125°C	8 SOT23
MAX16133HIB/V+T	-40°C to +125°C	8 SOT23
MAX16133LFM/V+T	-40°C to +125°C	8 SOT23
MAX16133LFM+T	-40°C to +125°C	8 SOT23
<b>MAX16134</b> MLG+T	-40°C to +125°C	8 SOT23
MAX16134NKQ/V+T	-40°C to +125°C	8 SOT23
MAX16134QAA+T	-40°C to +125°C	8 SOT23
MAX16134QLA+T	-40°C to +125°C	8 SOT23
<b>MAX16135</b> ATI+T	-40°C to +125°C	8 SOT23
MAX16135GQS/V+T	-40°C to +125°C	8 SOT23
MAX16135HRB+T	-40°C to +125°C	8 SOT23
MAX16135HRB/V+T	-40°C to +125°C	8 SOT23
MAX16135HRR/V+T	-40°C to +125°C	8 SOT23

+ Denotes a lead(Pb)-free/RoHS-compliant package.

T = Tape and reel.

/V denotes an automotive qualified part.

**Note:** See the Selector Guide for Reset Timeout Period, Nominal Input Voltages, and Hysteresis/Tolerance options.



## Revision History

REVISION NUMBER	REVISION DATE	DESCRIPTION	PAGES CHANGED
0	11/16	Initial release	—
1	1/17	Corrected part numbers in <i>Figure 3</i> and <i>Typical Application Circuit</i>	20
2	2/17	Updated <i>Selector Guide</i>	21
3	6/17	Updated <i>Electrical Characteristics</i> table, <i>Selector Guide</i> , and <i>Ordering Information</i> table	6, 16–18, 21, 22
4	8/17	Updated <i>Ordering Information</i> table	22
5	11/17	Added released part numbers to <i>Ordering Information</i> table and AEC-Q100 statement to <i>Benefits and Features</i> section	1, 22
6	12/17	Updated <i>Electrical Characteristics</i> table and <i>Ordering Information</i>	6, 22
7	1/18	Updated <i>Ordering Information</i>	22
8	2/18	Updated <i>Ordering Information</i>	22
9	3/18	Updated the <i>General Description</i> , <i>Benefits and Features</i> , and <i>Input Voltage</i> sections, <i>Electrical Characteristics</i> table, Table 1 and Table 4, and <i>Selector Guide</i> .	1, 6, 15–17, 21
10	7/18	Updated <i>Ordering Information</i> table	22
11	7/18	Updated <i>Absolute Maximum Ratings</i> and <i>Ordering Information</i>	5, 22
12	10/18	Updated <i>Electrical Characteristics</i> table and <i>Applications Information</i>	6, 19
13	12/18	Updated <i>Ordering Information</i> table	22
14	2/19	Updated <i>Ordering Information</i> table	22
15	10/19	Updated Table 2, <i>Selector Guide</i> , and <i>Ordering Information</i>	14, 19, 20
16	10/19	Updated <i>Pin Description</i> and <i>Applications Information</i>	8, 17
17	11/19	Updated Table 2, <i>Selector Guide</i> , and <i>Ordering Information</i>	14, 19, 20
18	12/19	Updated Table 1–9, <i>Selector Guide</i> , and <i>Ordering Information</i>	14–16, 19, 20
19	2/20	Updated <i>General Description</i> , <i>Benefits and Features</i> , and <i>Package Information</i>	1, 3
20	4/20	Updated <i>Typical Operating Characteristics</i> , <i>Pin Description</i> table, <i>Detailed Description</i> , <i>Applications Information</i> , <i>Selector Guide</i> , and <i>Ordering Information</i> table	5, 8, 9, 13–15, 17, 19, 20
21	9/20	Updated <i>Ordering Information</i> table	25
22	3/21	Updated <i>Electrical Characteristics</i> table, <i>Ordering Information</i> table	3, 4, 24
23	6/21	Updated <i>Ordering Information</i> table	24
24	8/21	Updated <i>Ordering Information</i> table, <i>Configuration Tables</i> , and <i>Selector Guide</i>	15, 17, 19, 22, 24
25	12/21	Updated <i>Ordering Information</i> table	24