



AirPrime HL7800 and HL7800-M

Product Technical Specification



SIERRA
WIRELESS®

41111094
7
October 04, 2019

Important Notice

Due to the nature of wireless communications, transmission and reception of data can never be guaranteed. Data may be delayed, corrupted (i.e., have errors) or be totally lost. Although significant delays or losses of data are rare when wireless devices such as the Sierra Wireless modem are used in a normal manner with a well-constructed network, the Sierra Wireless modem should not be used in situations where failure to transmit or receive data could result in damage of any kind to the user or any other party, including but not limited to personal injury, death, or loss of property. Sierra Wireless accepts no responsibility for damages of any kind resulting from delays or errors in data transmitted or received using the Sierra Wireless modem, or for failure of the Sierra Wireless modem to transmit or receive such data.

Safety and Hazards

Do not operate the Sierra Wireless modem in areas where cellular modems are not advised without proper device certifications. These areas include environments where cellular radio can interfere such as explosive atmospheres, medical equipment, or any other equipment which may be susceptible to any form of radio interference. The Sierra Wireless modem can transmit signals that could interfere with this equipment. Do not operate the Sierra Wireless modem in any aircraft, whether the aircraft is on the ground or in flight. In aircraft, the Sierra Wireless modem **MUST BE POWERED OFF**. When operating, the Sierra Wireless modem can transmit signals that could interfere with various onboard systems.

Note: Some airlines may permit the use of cellular phones while the aircraft is on the ground and the door is open. Sierra Wireless modems may be used at this time.

The driver or operator of any vehicle should not operate the Sierra Wireless modem while in control of a vehicle. Doing so will detract from the driver or operator's control and operation of that vehicle. In some states and provinces, operating such communications devices while in control of a vehicle is an offence.

Limitations of Liability

This manual is provided "as is". Sierra Wireless makes no warranties of any kind, either expressed or implied, including any implied warranties of merchantability, fitness for a particular purpose, or noninfringement. The recipient of the manual shall endorse all risks arising from its use.

The information in this manual is subject to change without notice and does not represent a commitment on the part of Sierra Wireless. SIERRA WIRELESS AND ITS AFFILIATES SPECIFICALLY DISCLAIM LIABILITY FOR ANY AND ALL DIRECT, INDIRECT, SPECIAL, GENERAL, INCIDENTAL, CONSEQUENTIAL, PUNITIVE OR EXEMPLARY DAMAGES INCLUDING, BUT NOT LIMITED TO, LOSS OF PROFITS OR REVENUE OR ANTICIPATED PROFITS OR REVENUE ARISING OUT OF THE USE OR INABILITY TO USE ANY SIERRA WIRELESS PRODUCT, EVEN IF SIERRA WIRELESS AND/OR ITS AFFILIATES HAS BEEN ADVISED OF THE POSSIBILITY OF SUCH DAMAGES OR THEY ARE FORESEEABLE OR FOR CLAIMS BY ANY THIRD PARTY.

Notwithstanding the foregoing, in no event shall Sierra Wireless and/or its affiliates aggregate liability arising under or in connection with the Sierra Wireless product, regardless of the number of events, occurrences, or claims giving rise to liability, be in excess of the price paid by the purchaser for the Sierra Wireless product.

Patents

This product may contain technology developed by or for Sierra Wireless Inc.

This product is manufactured or sold by Sierra Wireless Inc. or its affiliates under one or more patents licensed from MMP Portfolio Licensing.

Copyright

© 2019 Sierra Wireless. All rights reserved.

Trademarks

Sierra Wireless®, AirPrime®, AirLink®, AirVantage®, WISMO®, ALEOS® and the Sierra Wireless and Open AT logos are registered trademarks of Sierra Wireless, Inc. or one of its subsidiaries.

Watcher® is a registered trademark of NETGEAR, Inc., used under license.

Windows® and Windows Vista® are registered trademarks of Microsoft Corporation.

Macintosh® and Mac OS X® are registered trademarks of Apple Inc., registered in the U.S. and other countries.

QUALCOMM® is a registered trademark of QUALCOMM Incorporated. Used under license.

Other trademarks are the property of their respective owners.

Contact Information

Sales information and technical support, including warranty and returns	Web: sierrawireless.com/company/contact-us/ Global toll-free number: 1-877-687-7795 6:00 am to 5:00 pm PST
Corporate and product information	Web: sierrawireless.com

Document History

Version	Date	Updates
1.0	November 24, 2017	Creation
1.1	February 01, 2018	Added 3.3 Power Consumption States Updated: <ul style="list-style-type: none"> Table 2 General Features Table 5 Pin Definition 3.2 Current Consumption 3.16 Debug Interface 3.19.3 Rx Sensitivity
1.2	May 04, 2018	Added: <ul style="list-style-type: none"> 7.1 Japan Radio and Telecom Approval Table 9 Maximum Current Consumption Updated: <ul style="list-style-type: none"> GNSS to GPS 1.7 ESD Specifications 1.8.5 RoHS Directive Compliance 3.2 Current Consumption Table 23 Digital I/O Electrical Characteristics 3.11 Power On Signal (PWR_ON_N) 3.19 RF Interface 6 Reliability Specification
1.3	July 05, 2018	Added 1.8.3 ATEX Compliance Updated: <ul style="list-style-type: none"> Table 1 Supported Bands/Connectivity Table 2 General Features 1.5 Interfaces Table 5 Pin Definition Table 9 Maximum Current Consumption 3.2 Current Consumption 3.3 Power Consumption States 3.11 Power On Signal (PWR_ON_N) 3.12 Reset Signal (RESET_IN_N) Table 43 Typical Conducted Cat-M1 RX Sensitivity
1.4	July 10, 2018	Updated Table 10 Low Current Consumption Mode
1.5	July 25, 2018	Added: <ul style="list-style-type: none"> 1.8.2 Frequency Drift Correction 7 Legal Information HL7800-M Updated: <ul style="list-style-type: none"> Table 9 Maximum Current Consumption Moved Japan Approval to 7.1; updated Figure 25 Sample Japan Certification Indication
1.6	August 10, 2018	Updated <ul style="list-style-type: none"> 7.3 FCC Statement 7.4 IC Statement

Version	Date	Updates
2.0	September 10, 2018	Added 7.3.4 Antenna Installation
		Updated: <ul style="list-style-type: none"> • Table 1 Supported Bands/Connectivity • 1.7 ESD Specifications • Table 5 Pin Definition • Table 9 Maximum Current Consumption • Table 17 VGPIO Electrical Characteristics • Table 22 USB Electrical Characteristics • Table 23 Digital I/O Electrical Characteristics • Table 24 GPIO Pin Description • Table 25 UART1 Pin Description • Table 31 RESET_IN_N Electrical Characteristics
3.0	November 12, 2018	Added 3.3.3 Digital I/O during Hibernate Power Mode
		Updated: <ul style="list-style-type: none"> • Table 5 Pin Definition • 3.2 Current Consumption • 3.3.1.2 Extended DRX (eDRX) • 3.3.2 Power Modes • Table 17 VGPIO Electrical Characteristics • Table 20 USIM1 Electrical Characteristics • Table 23 Digital I/O Electrical Characteristics • 3.10 Main Serial Link (UART1) • 3.11 Power On Signal (PWR_ON_N) • 3.12 Reset Signal (RESET_IN_N) • 3.16 Debug Interfaces • Table 38 WAKE_UP Electrical Characteristics • Table 43 Typical Conducted Cat-M1 RX Sensitivity
3.1	November 13, 2018	Updated 3.2 Current Consumption
4.0	March 08, 2019	Added 5 Design Guidelines
		Updated: <ul style="list-style-type: none"> • Number of GPIOs from 11 to 12 • Table 1 Supported Bands/Connectivity • Table 2 General Features • 1.7 ESD Specifications • 1.8.4 Regulatory • Table 5 Pin Definition • 3 Detailed Interface Specifications
4.1	March 13, 2019	Updated 3.8 Electrical Information for Digital I/O
4.2	March 22, 2019	Added Table 44 Typical Conducted NB1 RX Sensitivity
		Updated: <ul style="list-style-type: none"> • 3.2 Current Consumption • 3.3.1.1 Power Saving Mode (PSM)
4.3	April 04, 2019	Updated 3.2 Current Consumption
5.0	May 08, 2019	Added: <ul style="list-style-type: none"> • VBATT_PA_EN (pin 41) • 3.21 External RF Voltage Control Indicator • 7.2 Korean Approval

Version	Date	Updates
5.0	May 08, 2019	Updated: <ul style="list-style-type: none">• 3.2 Current Consumption• 3.3.2 Power Modes• 3.7 USB Interface• 3.10 Main Serial Link (UART1)• Table 29 PWR_ON_N Managed Timing• Table 33 ADC Electrical Characteristics
6.0	August 06, 2019	Updated IO state in: <ul style="list-style-type: none">• 3.10 Main Serial Link (UART1)• 3.21 External RF Voltage Control Indicator
7	October 03, 2019	Updated 3.3.1 3GPP Power Saving Features ADCs, Clock Interface, PWR_ON_N now available Updated Pin Definition table (pre/post reset state; power supply domain) - pins C11, C24-C29, C44 Updated 3.4 VGPIIO Updated Table 29 PWR_ON_N Managed Timing Updated Table 31 RESET_IN_N Electrical Characteristics Updated 3.20 TX Indictor (TX_ON) Updated Table 50 GPS Performance Updated Figure 24 Antenna Connection

»» Contents

1. INTRODUCTION	13
1.1. Common Flexible Form Factor (CF ³)	14
1.2. Physical Dimensions	14
1.3. General Features.....	14
1.4. Architecture.....	16
1.5. Interfaces	17
1.6. Connection Interface	17
1.7. ESD Specifications	18
1.8. Environmental and Certifications.....	18
1.8.1. Environmental Specifications.....	18
1.8.2. Frequency Drift Correction.....	19
1.8.3. ATEX Compliance	19
1.8.4. Regulatory.....	19
1.8.5. RoHS Directive Compliance	19
1.8.6. Disposing of the Product.....	20
1.9. References	20
2. PAD DEFINITION	21
2.1. Pin Types.....	25
2.2. Pad Configuration (Top View, Through Module).....	26
3. DETAILED INTERFACE SPECIFICATIONS	27
3.1. Power Supply.....	27
3.2. Current Consumption	28
3.3. Power Consumption States.....	31
3.3.1. 3GPP Power Saving Features.....	31
3.3.2. Power Modes	35
3.3.3. Digital I/O during Hibernate Power Mode	36
3.4. VGPIO	38
3.5. Real Time Clock (BAT_RTC)	39
3.6. USIM Interface.....	40
3.6.1. UIM1_DET	41
3.7. USB Interface	41
3.8. Electrical Information for Digital I/O	41
3.9. General Purpose Input/Output (GPIO).....	42
3.10. Main Serial Link (UART1).....	43
3.10.1. 8-wire Application	44
3.10.2. 4-wire Application	44
3.10.3. 2-wire Application	44
3.11. Power On Signal (PWR_ON_N).....	45
3.11.1. PWR_ON_N Not Managed (Default).....	45

3.11.2.	PWR_ON_N Managed	46
3.12.	Reset Signal (RESET_IN_N).....	47
3.13.	Analog to Digital Converter (ADC)	48
3.14.	Clock Interface.....	49
3.15.	PCM.....	49
3.16.	Debug Interfaces	49
3.16.1.	Command Line Interface (CLI)	49
3.16.2.	Modem Logs interface	50
3.17.	Wake Up Signal (WAKE_UP).....	50
3.18.	Fast Shutdown Signal (FAST_SHUTDOWN_N).....	51
3.19.	RF Interface.....	51
3.19.1.	RF Connection.....	51
3.19.2.	Maximum Output Power	52
3.19.3.	Rx Sensitivity	52
3.20.	TX Indicator (TX_ON).....	53
3.21.	External RF Voltage Control Indicator.....	54
3.22.	GPS Interface	55
3.22.1.	GPS Performance.....	55
3.22.2.	GPS Antenna Indicator (EXT_LNA_GPS_EN).....	55
4.	MECHANICAL DRAWINGS	56
5.	DESIGN GUIDELINES	59
5.1.	Power Supply Design	59
5.2.	Power Cycle.....	59
5.3.	ESD Guidelines for USIM	59
5.4.	ESD Guidelines for USB.....	60
5.5.	Radio Frequency Integration	61
6.	RELIABILITY SPECIFICATION	62
6.1.	Preconditioning Test.....	62
6.2.	Performance Test	62
6.3.	Aging Tests.....	63
6.4.	Characterization Tests.....	64
7.	LEGAL INFORMATION	65
7.1.	Japan Radio and Telecom Approval	65
7.2.	Korean Approval.....	65
7.3.	FCC Statement.....	65
7.3.1.	Radiation Exposure Statement.....	66
7.3.2.	End Product Labeling	66
7.3.3.	Manual Information to the End User	66
7.3.4.	Antenna Installation	66
7.4.	IC Statement.....	67
7.4.1.	Radiation Exposure Statement / Déclaration d'Exposition aux Radiations	68

7.4.2.	End Product Labeling / Plaque Signalétique du Produit Final.....	69
7.4.3.	Manual Information to the End User / Manuel d'Information à l'Utilisateur Final.....	69
8.	ORDERING INFORMATION	70
9.	TERMS AND ABBREVIATIONS	71



List of Figures

Figure 1.	Architecture Overview	16
Figure 2.	Mechanical Overview (Top View).....	17
Figure 3.	Pad Configuration (Top View through Module).....	26
Figure 4.	PSM Example (Simplified).....	32
Figure 5.	eDRX Example (PTW: 4 Paging Occurrences).....	33
Figure 6.	eDRX Power Consumption Profile Interruption.....	34
Figure 7.	PSM I/O Toggling during TAU and the Active Window (T3324)	37
Figure 8.	eDRX Cycle of 20s sleep and 1.024s of Activity	37
Figure 9.	eDRX with Extra Calibration Wakes.....	38
Figure 10.	Stable eDRX Cycle of 81.92s after Calibration	38
Figure 11.	8-wire UART Application Example	44
Figure 12.	4-wire UART Application Example	44
Figure 13.	2-wire UART Application Example	44
Figure 14.	Power Up and Power Down Sequence without PWR_ON_N.....	45
Figure 15.	Power Up Sequence with PWR_ON_N Cold Start	46
Figure 16.	Power On Sequence with PWR_ON_N	47
Figure 17.	TX_ON State during TX Burst.....	54
Figure 18.	VBATT_PA_EN State during RX/TX windows	54
Figure 19.	Mechanical Drawing	56
Figure 20.	Dimensions Drawing	57
Figure 21.	Footprint Drawing	58
Figure 22.	EMC and ESD Components Close to the USIM	60
Figure 23.	ESD Protection for USB	60
Figure 24.	Antenna Connection.....	61
Figure 25.	Sample Japan Certification Indication.....	65
Figure 26.	Sample Korean Approval	65



List of Tables

Table 1.	Supported Bands/Connectivity	13
Table 2.	General Features	14
Table 3.	Environmental Specifications	18
Table 4.	Values for ATEX Compliance	19
Table 5.	Pin Definition	21
Table 6.	Pin Type Codes	25
Table 7.	Power Supply Pin Description	27
Table 8.	Power Supply Electrical Characteristics	27
Table 9.	Maximum Current Consumption	27
Table 10.	Low Current Consumption Mode Cat-M1	28
Table 11.	Low Current Consumption Mode Cat-NB1	29
Table 12.	Typical Current Consumption for LTE Cat-M1 in Connected Mode for All Bands	30
Table 13.	Expected Typical Current Consumption for NB -1 in Connected Mode for All Bands	30
Table 14.	eDRX-Related Commands	34
Table 15.	Low Power Modes	35
Table 16.	VGPIO Pin Description	39
Table 17.	VGPIO Electrical Characteristics	39
Table 18.	BAT_RTC Electrical Characteristics	39
Table 19.	USIM1 Pin Description	40
Table 20.	USIM1 Electrical Characteristics	40
Table 21.	USB Pin Description	41
Table 22.	USB Electrical Characteristics	41
Table 23.	Digital I/O Electrical Characteristics	42
Table 24.	GPIO Pin Description	42
Table 25.	UART1 Pin Description	43
Table 26.	PWR_ON_N Pin Description	45
Table 27.	PWR_ON_N Electrical Characteristics	45
Table 28.	PWR_ON_N Not Managed Timing	46
Table 29.	PWR_ON_N Managed Timing	47
Table 30.	RESET_IN_N Pin Description	48
Table 31.	RESET_IN_N Electrical Characteristics	48
Table 32.	ADC Pin Description	48
Table 33.	ADC Electrical Characteristics	48
Table 34.	Clock Interface Pin Description	49
Table 35.	CLI Interface Pin Description	49
Table 36.	Modem Logs Interface Pin Description	50
Table 37.	WAKE_UP Pin Description	50

Table 38.	WAKE_UP Electrical Characteristics	50
Table 39.	FAST_SHUTDOWN_N Pin Description	51
Table 40.	FAST_SHUTDOWN_N Electrical Characteristics	51
Table 41.	RF Main Pin Description.....	51
Table 42.	Maximum Output Power	52
Table 43.	Typical Conducted Cat-M1 RX Sensitivity	52
Table 44.	Typical Conducted NB1 RX Sensitivity	53
Table 45.	TX_ON Pin Description	53
Table 46.	VBATT_PA_EN Pin Description.....	54
Table 47.	VBATT_PA_EN Characteristics	55
Table 48.	GPS Antenna Specifications	55
Table 49.	GPS Performance	55
Table 50.	Preconditioning Test.....	62
Table 51.	Performance Test.....	62
Table 52.	Aging Tests.....	63
Table 53.	Characterization Tests	64
Table 54.	Ordering Information	70



1. Introduction

This document is the Product Technical Specification for the AirPrime HL7800 and HL7800-M Embedded Modules designed for M2M and Internet of Things (IoT) markets. It defines the high-level product features and illustrates the interfaces for these features. This document is intended to cover the hardware aspects of the product, including electrical and mechanical.

The AirPrime HL7800 and HL7800-M modules belong to the AirPrime HL Series from the Essential Connectivity Module family. These are industrial grade Embedded Wireless Modules that provides data connectivity on LTE (as listed in Table 1 Supported Bands/Connectivity).

The AirPrime HL7800 and HL7800-M modules support a large variety of interfaces such as USB FS, UART, ADC, GPIOs, and also support the new ultra-low-power-consumption hibernation modes to provide customers with the highest level of flexibility in implementing high-end solutions.

Table 1. Supported Bands/Connectivity

LTE Band	Transmit Band (Tx)		Receive Band (Rx)		Cat-M1 (HL7800 and HL7800-M)	Cat-NB1 (HL7800 only)
	Minimum	Maximum	Minimum	Maximum		
B1	1920 MHz	1980 MHz	2110 MHz	2170 MHz	✓	✓
B2	1850 MHz	1910 MHz	1930 MHz	1990 MHz	✓	✓
B3	1710 MHz	1785 MHz	1805 MHz	1880 MHz	✓	✓
B4	1710 MHz	1755 MHz	2110 MHz	2155 MHz	✓	✓
B5	824 MHz	849 MHz	869 MHz	894 MHz	✓	✓
B8	880 MHz	915 MHz	925 MHz	960 MHz	✓	✓
B9	1749.9 MHz	1784.9 MHz	1844.9 MHz	1879.9 MHz	*	*
B10	1710 MHz	1770 MHz	2110 MHz	2170 MHz	*	*
B12	699 MHz	716 MHz	729 MHz	746 MHz	✓	✓
B13	777 MHz	787 MHz	746 MHz	756 MHz	✓	✓
B14	788 MHz	798 MHz	758 MHz	768 MHz	✓	✓
B17	704 MHz	716 MHz	734 MHz	746 MHz	*	✓
B18	815 MHz	830 MHz	860 MHz	875 MHz	✓	✓
B19	830 MHz	845 MHz	875 MHz	890 MHz	✓	✓
B20	832 MHz	862 MHz	791 MHz	821 MHz	✓	✓
B25	1850 MHz	1915 MHz	1930 MHz	1995 MHz	✓	✓
B26	814 MHz	849 MHz	859 MHz	894 MHz	✓	✓
B27	807 MHz	824 MHz	852 MHz	869 MHz	✓	*
B28	703 MHz	748 MHz	758 MHz	803 MHz	✓	✓
B66	1710 MHz	1780 MHz	2110 MHz	2200 MHz	✓	✓

* Will be supported in a future release.

Note: RF bands supported are configurable through AT command. The software-based radio allows for the ability to support extra bands for worldwide connectivity.

1.1. Common Flexible Form Factor (CF³)

The AirPrime HL7800 and HL7800-M modules belong to the Common Flexible Form Factor (CF³) family of modules. This family consists of a series of WWAN modules that share the same mechanical dimensions (same width and length with varying thicknesses) and footprint. The CF³ form factor provides a unique solution to a series of problems faced commonly in the WWAN module space as it:

- Accommodates multiple radio technologies (LTE advanced) and band groupings.
- Supports bit-pipe (Essential Module Series) and value add (Smart Module Series) solutions.
- Offers electrical and functional compatibility.
- Provides Direct Mount as well as Socket-ability depending on customer needs.

1.2. Physical Dimensions

AirPrime HL7800 and HL7800-M modules are compact, robust, fully shielded modules with the following dimensions:

- Length: 18.0 mm
- Width: 15.0 mm
- Thickness: 2.4 mm
- Weight: 1.17 g

Note: Dimensions specified above are typical values.

1.3. General Features

The table below summarizes the AirPrime HL7800 and HL7800-M's features.

Table 2. General Features

Feature	Description
Physical	<ul style="list-style-type: none"> • Small form factor (86-pad solderable LGA pad) – 15.0mm x 18.0mm x 2.4mm (nominal) • Metal shield can • RF connection pads (RF main and RF GPS) • Baseband signals connection
Power supply	Single or double supply voltage (VBATT and VBATT_PA) – 3.2V – 4.35V

Feature	Description
RF	<ul style="list-style-type: none"> • Cat-M1 <ul style="list-style-type: none"> ▪ Power Class 3 (23dBm) ▪ Software based radio allowing support of extra bands for worldwide operation (will be supported in a future release) • Cat-NB1 (not supported on the HL7800-M) <ul style="list-style-type: none"> ▪ Power Class 3 (23dBm) ▪ Software based radio allowing support of extra bands for worldwide operation (will be supported in a future release) • GPS* <ul style="list-style-type: none"> ▪ 1575.42 MHz <hr/> <p><i>Note: The GPS receiver shares the same RF resources as the 4G receiver. The end-device target should allow GPS positioning for asset management applications where infrequent and no real-time position updates are required.</i></p>
SIM interface	<ul style="list-style-type: none"> • 1.8V only support (legacy 3V SIM is not supported; this should not have any impact on design) (Note: Modern SIM cards all support 1.8V.) • SIM extraction / hot plug detection • SIM/USIM support • Conforms with ETSI UICC Specifications. • Supports SIM application tool kit with proactive SIM commands
Application interface	<ul style="list-style-type: none"> • AT command interface – 3GPP 27.007 standard, plus proprietary extended AT commands • CMUX multiplexing over UART • USB Full Speed (FS)*
Protocol stack	<ul style="list-style-type: none"> • Cat-M1 <ul style="list-style-type: none"> ▪ 3GPP Rel. 13 ▪ Half-duplex ▪ Channel bandwidth 1.4MHz ▪ LTE carrier bandwidth 1.4 / 3 / 5 / 10 / 15 / 20 MHz ▪ Up to 375kbit/s uplink, 300 kbit/s downlink ▪ Extended Coverage Mode A ▪ PSM (Power Save Mode) ▪ I-DRX (Idle Mode Discontinuous Reception) ▪ C-DRX (Connected Mode Discontinuous Reception) ▪ Idle mode mobility ▪ Connected mode mobility ▪ eDRX (Extended Discontinuous Reception) ▪ CiOT optimizations (U-Plane, C-Plan)* • Cat-NB1 (not supported on the HL7800-M) <ul style="list-style-type: none"> ▪ 3GPP Rel. 13 ▪ Half-duplex ▪ Channel bandwidth 180KHz ▪ LTE carrier bandwidth 1.4 / 3 / 5 / 10 / 15 / 20 MHz ▪ Up to 100 kbit/s in downlink ▪ Operational mode – Inband, Guard band, Standalone ▪ CiOT EPS optimizations (Data over NAS) ▪ NIDD over SGi tunneling ▪ NIDD over SCEF ▪ Extended coverage

Feature	Description
Protocol stack	<ul style="list-style-type: none"> Flexible selection <ul style="list-style-type: none"> Manual system selection across RATs Dynamic system selection across RATs (preferred RAT)*
SMS	<ul style="list-style-type: none"> SMS over SG MO/MT SMS storage to SIM card or ME storage
Connectivity	<ul style="list-style-type: none"> Multiple cellular packet data profiles Sleep mode for minimum idle power draw Mobile-originated PDP context activation / deactivation Static and Dynamic IP address. The network may assign a fixed IP address or dynamically assign one using DHCP (Dynamic Host Configuration Protocol). PDP context type (IPv4, IPv6, IPv4v6). IP Packet Data Protocol context RFC1144 TCP/IP header compression
Environmental	Operating temperature ranges (industrial grade): <ul style="list-style-type: none"> Class A: -30°C to +70°C Class B: -40°C to +85°C
RTC	Real Time Clock (RTC)*

* Will be available in a future release.

1.4. Architecture

The figure below presents an overview of the AirPrime HL7800 and HL7800-M's internal architecture and external interfaces.

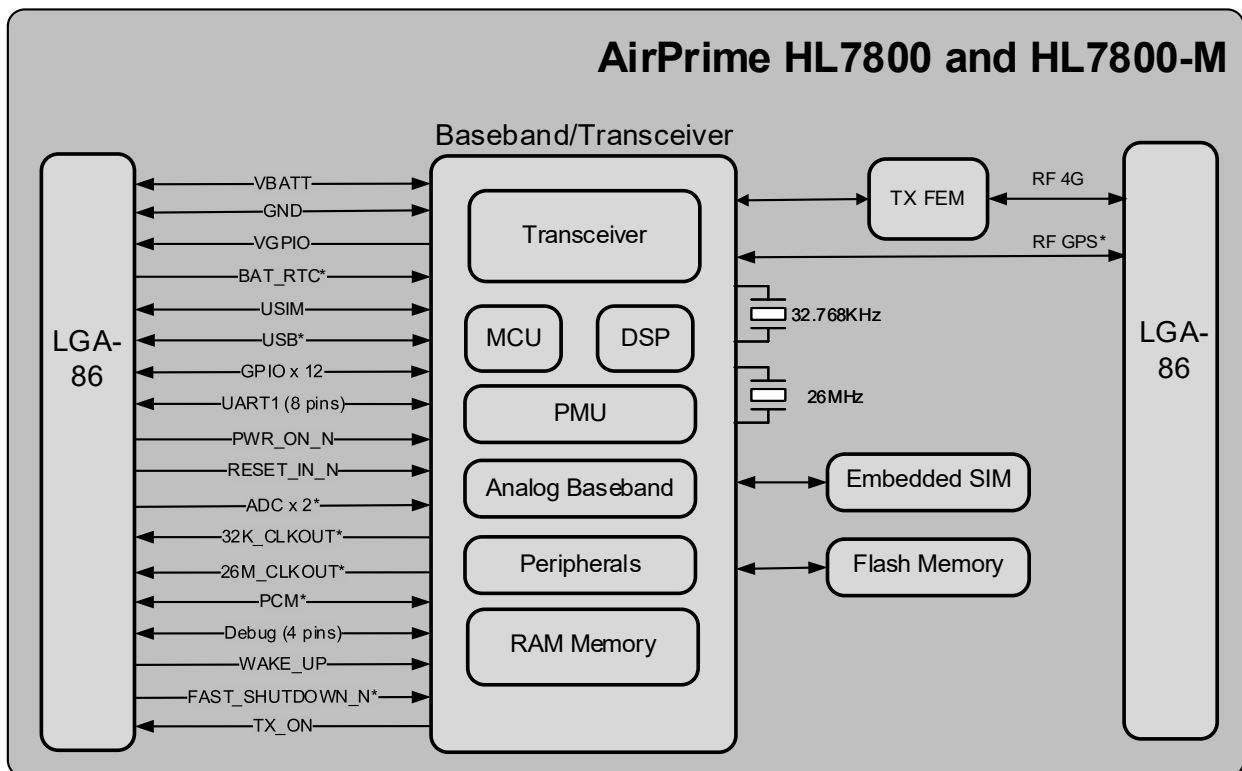

* Will be available in a future release

Figure 1. Architecture Overview

1.5. Interfaces

The AirPrime HL7800 and HL7800-M modules provide the following interfaces and peripheral connectivity:

- 1x – VGPIO (1.8V)
- 1x – BAT_RTC backup battery interface (will be available in a future firmware release)
- 1x – 1.8V USIM
- 1x – USB FS
- 12x – GPIOs
- 1x – 8-wire UART
- 1x – Active Low POWER ON (will be available in a future firmware release)
- 1x – Active Low RESET
- 2x – ADC
- 2x – System clock out (32.768 KHz and 26 MHz)
- 1x – PCM (will be available in a future firmware release)
- 1x – 4-wire UART for debug interface only
- 1x – Wake up signal
- 1x – Fast shutdown signal (will be available in a future firmware release)
- 1x – Main RF Antenna
- 1x – TX indicator
- 1x – GPS Antenna (will be available in a future firmware release)

1.6. Connection Interface

AirPrime HL7800 and HL7800-M modules are LGA form factor devices. All electrical and mechanical connections are made through the 86 Land Grid Array (LGA) pads on the bottom side of the PCB.

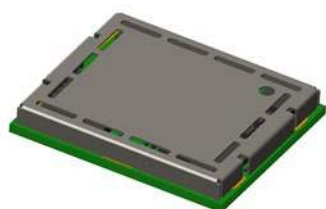

Figure 2. Mechanical Overview (Top View)

The 86 pads have the following distribution:

- 66 inner signal pads, 1x0.5mm, pitch 0.8mm
- 16 inner ground pads, 1.0x1.0mm, pitch 1.825mm/1.475mm
- 4 outer corner ground pads, 0.85x0.97mm

1.7. ESD Specifications

- IEC-61000-4-2 (test carried out on test vehicle including ESD protection)
 - Contact Voltage: $\pm 2\text{kV}$, $\pm 4\text{kV}$, $\pm 6\text{kV}$
 - GPS pad C38: $\pm 500\text{V}$
 - Air Voltage: $\pm 2\text{kV}$, $\pm 4\text{kV}$, $\pm 8\text{kV}$
- JESD22-A114 $\pm 250\text{V}$ Human Body Model
- JESD22-C101C $\pm 250\text{V}$ Charged Device Model

1.8. Environmental and Certifications

1.8.1. Environmental Specifications

The environmental specification for both operating and storage conditions are defined in the table below.

Table 3. Environmental Specifications

Conditions	Range
Operating Class A	-30°C to $+70^{\circ}\text{C}$
Operating Class B	-40°C to $+85^{\circ}\text{C}$
Storage	-40°C to $+85^{\circ}\text{C}$

Class A is defined as the operating temperature ranges that the device:

- Shall exhibit normal function during and after environmental exposure.
- Shall meet the minimum requirements of 3GPP or appropriate wireless standards.

Class B is defined as the operating temperature ranges that the device:

- Shall remain fully functional during and after environmental exposure
- Shall exhibit the ability to establish an SMS or DATA call (emergency call) at all times even when one or more environmental constraint exceeds the specified tolerance.
- Unless otherwise stated, full performance should return to normal after the excessive constraint(s) have been removed.

1.8.2. Frequency Drift Correction

The HL7800 and HL7800-M are environment-sensitive like any electronic device, but able to correct temperature and aging effects automatically. Parameters to be considered when addressing the environmental effect on the HL7800 and HL7800-M are as follows:

- Maximum deviation correction: 20 ppm
- Environmental Temperature effect: 0.5 ppm
- Factory reflow effect: 1 ppm + 1 ppm / reflow
- Aging effect: 1 ppm /year of use

For example, if an HL7800 module is mounted on a single side (1 reflow) customer PCB and used for 10 years between -40 and +85°C, the frequency drift will be up to $0.5 + (1 + 1) + (1 * 10) = 12.5$ ppm, which is in the limits of the 20 ppm maximum correction.

1.8.3. ATEX Compliance

The following table lists the inductor and capacitor values to be considered for ATEX certification of the system hosting the HL7800 and HL7800-M modules. All supplies in the modules are linear LDO except for one 1.3V DC/DC step-down.

Table 4. Values for ATEX Compliance

Parameter	Value	Tolerance
Total Inductance	2.21 μ H	30%
Total Capacitance	43.64 μ F	20%

1.8.4. Regulatory

The AirPrime HL7800 and HL7800-M modules will be compliant with the following regulations:

- RED
- FCC
- IC
- RCM
- JRF/JPA
- KC

1.8.5. RoHS Directive Compliance

AirPrime HL7800 and HL7800-M modules are compliant with RoHS Directive 2011/65/EU, including directive 2015/863 amending annex II, which sets limits for the use of certain restricted hazardous substances. This directive states that electrical and electronic equipment put on the market does not contain lead, mercury, cadmium, hexavalent chromium, polybrominated biphenyls (PBB), polybrominated diphenyl ethers (PBDE), Bis (2-ethylhexyl) phthalate (DEHP), Butyl benzyl phthalate (BBP), Dibutyl phthalate (DBP) or Di-isobutyl phthalate (DIBP) above threshold limits.

1.8.6. Disposing of the Product

This electronic product is subject to the EU Directive 2012/19/EU for Waste Electrical and Electronic Equipment (WEEE). As such, this product must not be disposed of at a municipal waste collection point. Please refer to local regulations for directions on how to dispose of this product in an environmentally friendly manner.



1.9. References

- [1] AirPrime HL78xx Customer Process Guidelines
Reference Number: 41112095
- [2] AirPrime HL78xx AT Commands Interface Guide
Reference Number: 41111821
- [3] AirPrime HL Series Development Kit User Guide
Reference Number: 4114877
- [4] AirPrime HL7800 Low Power Modes Application Note
Reference Number: 2174229
- [5] AirPrime HL7800-M MNO and RF Band Customization at Customer Production Site
Application Note
Reference Number: 2174213



2. Pad Definition

AirPrime HL7800 and HL7800-M pins are divided into 2 functional categories.

- **Core functions and associated pins** cover all the mandatory features for M2M connectivity and will be available by default across all CF³ family of modules. These Core functions are always available and always at the same physical pad locations. A customer platform using only these functions and associated pads are guaranteed to be forward and/or backward compatible with the next generation of CF³ modules.
- **Extension functions and associated pins** bring additional capabilities to the customer. Whenever an Extension function is available on a module, it is always at the same pad location.

Other pins marked as “not connected” or “reserved” should not be used.

Table 5. Pin Definition

Pad #	Signal Name	Function	I/O	Pre and Post Reset State*	Power Supply Domain	Recommendation for Unused Pads	Type
C1	GPIO1	General purpose input/output	I/O	PU	1.8V (VGPIO)	Left open	Extension
C2	UART1_RI	UART1 Ring indicator	O	PU**	1.8V (VGPIO)	Connect to test point	Core
C3	UART1_RTS	UART1 Request to send	I	PU	1.8V (VGPIO)	Connect to test point	Core
C4	UART1_CTS	UART1 Clear to send	O	PU	1.8V (VGPIO)	Connect to test point	Core
C5	UART1_TX	UART1 Transmit data	I	PU	1.8V (VGPIO)	Connect to test point	Core
C6	UART1_RX	UART1 Receive data	O	PU	1.8V (VGPIO)	Connect to test point	Core
C7	UART1_DTR	UART1 Data terminal ready	I	PU	1.8V (VGPIO)	Connect to test point	Core
C8	UART1_DCD	UART1 Data carrier detect	O	PU	1.8V (VGPIO)	Connect to test point	Core
C9	UART1_DSR	UART1 Data set ready	O	PU	1.8V (VGPIO)	Connect to test point	Core
C10	GPIO2	General purpose input/output	I/O	PD**	1.8V (VGPIO)	Connect to test point	Core
C11	RESET_IN_N	Input reset signal	I	PU	1.8V	Left open	Core
C12	USB_D-	USB Data Negative (Full Speed)	I/O		3.3V	Connect to test point	Extension
C13	USB_D+	USB Data Positive (Full Speed)	I/O		3.3V	Connect to test point	Extension

Pad #	Signal Name	Function	I/O	Pre and Post Reset State*	Power Supply Domain	Recommendation for Unused Pads	Type
C14	NC	Not Connected				Left open	Not connected
C15	NC	Not Connected				Left open	Not connected
C16	USB_VBUS	USB VBUS	I		5V	Mandatory connection if USB is used	Extension
C17	NC	Not Connected				Left open	Not connected
C18	NC	Not Connected				Left open	Not connected
C19	NC	Not Connected				Left open	Not Connected
C20	NC	Not Connected				Left open	Not Connected
C21	BAT_RTC	Power supply for RTC backup	I			Left open	Extension
C22	26M_CLKOUT	26M System Clock Output	O	PD	1.8V (VGPIO)	Left open	Extension
C23	32K_CLKOUT	32.768kHz System Clock Output	O	PU	1.8V (VGPIO)	Left open	Extension
C24	ADC1	Analog to digital converter	I	PD	1.8V (VGPIO)	Left open	Extension
C25	ADC0	Analog to digital converter	I	PU	1.8V (VGPIO)	Left open	Extension
C26	UIM1_VCC	1.8V USIM1 Power supply	O		1.8V	Mandatory connection	Core
C27	UIM1_CLK	1.8V USIM1 Clock	O	PD	1.8V (VGPIO)	Mandatory connection	Core
C28	UIM1_DATA	1.8V USIM1 Data	I/O	PD	1.8V (VGPIO)	Mandatory connection	Core
C29	UIM1_RESET	1.8V USIM1 Reset	O	PD	1.8V (VGPIO)	Mandatory connection	Core
C30	GND	Ground	0V		0V	Recommended connection but can be left open	Extension
C31	NC	Not Connected					Not connected
C32	GND	Ground	0V		0V	Recommended connection but can be left open	Extension
C33	PCM_OUT	PCM data out	O	PU	1.8V (VGPIO)	Left open	Extension
C34	PCM_IN	PCM data in	I	PU	1.8V (VGPIO)	Left open	Extension
C35	PCM_SYNC	PCM sync out	I/O	PU	1.8V (VGPIO)	Left open	Extension
C36	PCM_CLK	PCM clock	I/O	PD	1.8V (VGPIO)	Left open	Extension

Pad #	Signal Name	Function	I/O	Pre and Post Reset State*	Power Supply Domain	Recommendation for Unused Pads	Type
C37	GND	Ground	0V		0V	Mandatory connection	Core
C38	RF_GPS	RF_GPS				Left open	Core
C39	GND	Ground	0V		0V	Mandatory connection	Core
C40	GPIO7	General purpose input/output	I/O	PU	1.8V (VGPIO)	Left open	Core
C41	GPIO8 / VBATT_PA_EN	General purpose input/output / External RF voltage control	I/O	PD	1.8V (VGPIO)	Left open	Core
C42	NC	Not Connected					Not connected
C43	EXT_LNA_GPS_EN	External GPS LNA enable		PU		Left open	Extension
C44	WAKE_UP	Wake up signal	I		1.8V	Mandatory connection	Extension
C45	VGPIO	GPIO voltage output	O		1.8V (VGPIO)	Left open	Core
C46	GPIO6	General purpose input/output	I/O	PD	1.8V (VGPIO)	Left open	Core
C47	NC	Not Connected				Left open	Not connected
C48	GND	Ground	0V		0V	Mandatory connection	Core
C49	RF_MAIN	RF Input/output				Mandatory connection	Core
C50	GND	Ground	0V		0V	Mandatory connection	Core
C51	GPIO14	General purpose input/output	I/O	PU	1.8V (VGPIO)	Connect to test point	Extension
C52	GPIO10	General purpose input/output	I/O	PU	1.8V (VGPIO)	Connect to test point	Extension
C53	GPIO11	General purpose input/output	I/O	PU	1.8V (VGPIO)	Connect to test point	Extension
C54	GPIO15	General purpose input/output	I/O	PU	1.8V (VGPIO)	Connect to test point	Extension
C55	UART0_RX	Debug Receive data	O	PU	1.8V (VGPIO)	Mandatory connection	Extension
C56	UART0_TX	Debug Transmit data	I	PU	1.8V (VGPIO)	Mandatory connection	Extension
C57	UART0_CTS	Debug Clear to Send	O	PU	1.8V (VGPIO)	Mandatory connection	Extension
C58	UART0_RTS	Debug Request to Send	I	PD	1.8V (VGPIO)	Mandatory connection	Extension
C59	PWR_ON_N	Active Low Power On control signal	I		1.8V	Mandatory connection	Core
C60	TX_ON	TX transmission indication	O	PU	1.8V (VGPIO)	Left open	Extension

Pad #	Signal Name	Function	I/O	Pre and Post Reset State*	Power Supply Domain	Recommendation for Unused Pads	Type
C61	VBATT_PA	Power supply (refer to section 3.1 Power Supply for more information)	I		3.2V (min) 3.7V (typ) 4.35V (max)	Mandatory connection	Core
C62	VBATT_PA	Power supply (refer to section 3.1 Power Supply for more information)	I		3.2V (min) 3.7V (typ) 4.35V (max)	Mandatory connection	Core
C63	VBATT	Power supply (refer to section 3.1 Power Supply for more information)	I		3.2V (min) 3.7V (typ) 4.35V (max)	Mandatory connection	Core
C64	UIM1_DET / GPIO3	USIM1 Detection / General purpose input/output	I/O	PD	1.8V (VGPIO)	Left open	Core
C65	FAST_SHUTDOWN_N / GPIO4	Fast Shutdown signal / General purpose input/output	I/O	PU	1.8V (VGPIO)	Left open	Extension
C66	GPIO5	General purpose input/output	I/O	PU	1.8V (VGPIO)	Left open	Extension
CG1 – CG4, G1 – G16	GND	Ground	GND		0V		Core

* This refers to the state before and after RESET_IN_N; state is Undefined during Reset, Hibernate or OFF modes. Refer to section 3.12 Reset Signal (RESET_IN_N) for more details.

** During hibernation (not applicable to Lite Hibernate mode), all the pulled up (PU) signals will toggle at the rate of wake events. Therefore, if the RI signal is to be used in a system to warn the main MCU of an incoming network event (like SMS or DATA), this RI signal cannot be used as it will toggle at the rate of the eDRX or PSM recurrent wakes. It is therefore recommended to use GPIO2 with a built-in pull down (PD) instead of RI. This will allow the module to trigger the GPIO instead of the RI safely, without unwanted toggles.

2.1. Pin Types

Table 6. Pin Type Codes

Type	Definition
I	Digital Input
O	Digital Output
I/O	Digital Input / Output
T	Tristate
T/PU	Tristate with pull-up enabled
T/PD	Tristate with pull-down enabled
PU	Pull-up enabled
PD	Pull-down enabled
N/A	Not Applicable



3. Detailed Interface Specifications

Note: If not specified, all electrical values are given for VBATT=3.7V and an operating temperature of 25°C.

For standard applications, VBATT and VBATT_PA must be tied externally to the same power supply. For some specific applications, the module supports separate VBATT and VBATT_PA connection if the requirements below are fulfilled.

3.1. Power Supply

The AirPrime HL7800 and HL7800-M modules are supplied through the VBATT and VBATT_PA signals.

Note: The rise of the VBATT power signal initiates the power on sequence of the module. Refer to sections 3.11 Power On Signal (PWR_ON_N) and 3.12 Reset Signal (RESET_IN_N) for additional information.

Refer to the following table for the pin description of the Power Supply interface.

Table 7. Power Supply Pin Description

Pad Number	Signal Name	I/O	Description
C63	VBATT	I	Power supply (base band)
C61, C62	VBATT_PA	I	Power supply (radio frequency)
CG1 – CG4, G1 – G16	GND		Ground

Refer to the following table for the electrical characteristics of the Power Supply interface.

Table 8. Power Supply Electrical Characteristics

Supply	Minimum	Typical	Maximum
VBATT voltage (V)	3.2	3.7	4.35
VBATT_PA voltage (V) Full Specification	3.2	3.7	4.35
VBATT_PA voltage (V) Extended Range	2.8*	3.7	4.35

* No guarantee of 3GPP performances for VBATT_PA from 2.8 to 3.2V.

Table 9. Maximum Current Consumption

Supply	Maximum
VBATT	300mA
VBATT_PA	400mA

Note: If a single PSU is used, the recommended power supply capability is 400 mA + 300 mA = 700 mA.

Maximum values are provided for VSWR 2.5:1 with worst conditions among supported ranges of voltages and temperature (including GPS consumption).

3.2. Current Consumption

The following tables list the current consumption of the module at different conditions.

Note: Typical values are defined for VBATT/VBATT_PA at 3.7V and 25°C, for 50Ω impedance at all RF ports. USIM current consumption is not included.

Table 10. Low Current Consumption Mode Cat-M1

Modem Radio State	Lowest Power Mode	Configuration	Typical Average Value	Unit
OFF	OFF	Module is switched off by AT command and VBATs are connected	1.8	μA
PSM	Hibernate	Floor current	1.8	μA
	Lite Hibernate		30	μA
	Hibernate	1h cycle and T3324 = 20s	175 ^a	μA
	Lite Hibernate		185 ^a	μA
	Hibernate	24h cycle and T3324 = 20s	9 ^a	μA
	Lite Hibernate		35 ^a	μA
eDRX	TAU	Occurrence is network dependent	82	μAh
	Calibration	Applies to eDRX 81.92s and more	12	μAh
	Hibernate	Floor during eDRX	26	μA
	Lite Hibernate ^b		28	μA
	Hibernate Cycle	eDRX cycle (TI-eDRX) = 20.48s and PTW and DRX = 1.28s	135 ^c	μA
	Lite Hibernate Cycle ^b	Refer to section 3.3.1.2 Extended DRX (eDRX)	135 ^c	μA
	Hibernate Cycle	eDRX cycle (TI-eDRX) = 81.92s and PTW and DRX = 1.28s	50 ^c	μA
Lite Hibernate Cycle ^b	Refer to section 3.3.1.2 Extended DRX (eDRX)	55 ^c	μA	
DRX	SMS Reception	50 characters received	120	μAh
	Sleep	1.28s	2.4 (Target: 450 μA ^d)	mA
		2.56s	1.9 (Target: 300 μA ^d)	mA
Running	DRX independent, +KSLEEP=2 or Wake active	35	mA	

a Values are T3324 dependent.

b Recommended mode.

c Values are PTW and DRX dependent.

d Enhancement will be available in a future firmware version.

Refer to section 3.3.2 Power Modes for details regarding different low power modes.

The values above assume the following conditions:

- Cat-M1
- Good channel conditions (SINR > 5dB)
- Static scenario
- Cycle includes boot, cell acquisition, network attach, wait for timer expiry and back to sleep

Table 11. Low Current Consumption Mode Cat-NB1

Modem Radio State	Lowest Power Mode	Configuration	Typical Average Value	Unit
OFF	OFF	Module is switched off by AT command and VBATs are connected	1.8	μA
PSM	Hibernate	Floor current	1.8	μA
	Lite Hibernate		30	μA
	Hibernate	1h cycle and T3324 = 20s	235 ^a	μA
	Lite Hibernate		265 ^a	μA
	Hibernate	24h cycle and T3324 = 20s	10 ^a	μA
	Lite Hibernate		40 ^a	μA
eDRX	TAU	Occurrence is network dependent	100	μAh
	Calibration	Applies to eDRX 81.92s and more	21	μAh
	Hibernate	Floor during eDRX	22	μA
	Lite Hibernate ^b		27	μA
	Hibernate Cycle	eDRX cycle (TI-eDRX) = 20.48s and PTW and DRX = 1.28s	550 ^c	μA
	Lite Hibernate Cycle ^b	Refer to section 3.3.1.2 Extended DRX (eDRX)	560 ^c	μA
	Hibernate Cycle	eDRX cycle (TI-eDRX) = 81.92s and PTW and DRX = 1.28s	145 ^c	μA
	Lite Hibernate Cycle ^b	Refer to section 3.3.1.2 Extended DRX (eDRX)	150 ^c	μA
DRX	Sleep	1.28s	10 (Target: 1.3 mA ^d)	mA
		2.56s	4.2 (Target: 700 μA ^d)	mA
		10.24s	2.5 (Target: 200 μA ^d)	mA
	Running	DRX independent, +KSLEEP=2 or Wake active	38	mA

a Values are T3324 dependent.

b Recommended mode.

c Values are PTW and DRX dependent.

d Enhancement will be available in a future firmware version.

Refer to section 3.3.2 Power Modes for details regarding different low power modes.

The values above assume the following conditions:

- Cat-NB1
- Good channel conditions
- Static scenario
- Cycle includes boot, cell acquisition, network attachment, wait for timer expiry and back to sleep

Hibernate mode assumes the following conditions:

- I/Os are not held (I/O state is undefined; VGPIO is off)
- Customer application is not allowed to drive the module's I/Os to level > 0.2V
- UICC / USIM is off (ensure using a power saving compliant USIM/UICC)
- The module only wakes up by a high level on the WAKE_UP pin

Refer to document [4] AirPrime HL7800 Low Power Modes Application Note for additional information.

Table 12. Typical Current Consumption for LTE Cat-M1 in Connected Mode for All Bands

Parameter	Band	Output Power	Average Current (Typical Values)
LTE Cat-M1 <ul style="list-style-type: none"> • Modem State: Connected (Connection is established) • 4RB_DL and 1RB_UL on 3UL/DL sub frames 	1, 2, 3, 4, 25, 66	23 dBm	205 mA
		0 dBm	115 mA
	5, 8, 12, 13, 14, 18, 19, 20, 26, 27, 28	23 dBm	210 mA
		0 dBm	120 mA

Table 13. Expected Typical Current Consumption for NB -1 in Connected Mode for All Bands

Parameter	Band	Output Power	Average Current (Typical Values)
NB1 DL peak throughput (27.2kbps) 1 NPDCCH, 4 Guard, 3 NPDSCH, 12 Guard, 2 NPUSCH, 3 Guard	1, 2, 3, 4, 5, 8, 12, 13, 14, 17, 18, 19, 20, 25, 26, 28, 66	23 dBm	105 mA
		0 dBm	100 mA
NB1 UL peak throughput (62.5kbps) 1 NPDCCH, 8 Guard, 4 NPUSCH, 3 Guard		23 dBm	165 mA
		0 dBm	130 mA

3.3. Power Consumption States

3.3.1. 3GPP Power Saving Features

This section describes power saving features that are specified by 3GPP and that are supported by the HL7800 and HL7800-M modules. As per 3GPP specification, these features include power states and behaviors that pertain only to the cellular communication part of the module and do not consider memory states, I/O states, etc., of the module overall.

3.3.1.1. Power Saving Mode (PSM)

Power Saving Mode (PSM) is a 3GPP feature that allows the HL7800 and HL7800-M to minimize power consumption by registering on a PSM-supporting LTE network and entering PSM state (a very low power 'dormant' state). In order for the LTE network to know that the module is still present while it is in PSM state, the network will require the modem to periodically send a TAU (Tracking Area Update). If the module sends any data or does any other type of network transmission, the periodic TAU timer would be restarted. The periodic TAU periodicity is negotiated with the LTE network (i.e. the module will request the desired duration and the network will reply with the value to be used).

During the PSM state the module is unreachable by the network until it wakes up to perform the periodic TAU or the module is woken up by the WAKE_UP pin. Host processor can wake up the module using the WAKE_UP and send data to the network at any time during the PSM state. It is not necessary to synchronize the application data transmission periodicity with that of the periodic TAU.

While the HL7800 or HL7800-M is in PSM:

- Power consumption is significantly reduced with longer dormant periods
- Networking layer signaling overhead is reduced
- Radio resource signaling is reduced

Typical candidates for PSM are systems (such as monitors and sensors) that:

- Require long battery life (low power consumption)
- Infrequently send mobile originated data (every few hours, days, weeks, etc.), with optional reply data from network
- Tolerate modules being inaccessible for long periods of time
- Do not use mobile-terminated voice/data/SMS. Some networks may not allow mobile terminated data during PSM but using eDRX is a better option for applications that need mobile terminated (network originated) data.

PSM can be activated by the user either before or after the module attaches to the network. If PSM is activated before the attach, then module will request PSM during the attach. If PSM is activated after the attach, the module will immediately request PSM from the network with a TAU message. The user may also modify the requested PSM parameters afterwards, the module will update the network using a TAU. The following example describes how the module uses PSM by requesting PSM after the attach (as shown in Figure 4 PSM Example (Simplified)):

1. Module attaches on an LTE network.
2. User enables PSM via **+CPSMS**, specifying the desired periodic TAU timer and Active timer periods.
3. The PSM request including the settings (as specified in **+CPSMS**) are sent to the network by the module within a TAU message.

4. Network sends a response that indicates if the UE may use PSM and the PSM parameters that should be used. The network may adjust the PSM parameters from those requested by the UE.
5. If the network supports PSM:
 - a. Module enters idle mode (waiting for Rx from network).
 - b. When module has remained idle for the Active timer period, module powers off (except for maintaining timer and interrupts) and enters PSM.
 - c. Module remains in PSM for the specified TAU timer period or until the WAKE_UP pin wakes it.
 - i. If the module does not send any data or does not access the network before the TAU timer period expires, then the module sends a TAU to the network.
 - ii. If the module sends data to the network before the TAU timer period expires, the TAU timer is restarted. The module can be woken with the WAKE_UP in order to send data at any time. The network application server may send data back to the module before the PSM active timer expires. If the module sends data to the network more often than the periodic TAU timer period, the UE would not need to send a TAU.
 - d. Module enters idle mode and cycle repeats.

Note: Simplified current consumption pattern to illustrate general structure of PSM cycle power state transitions.

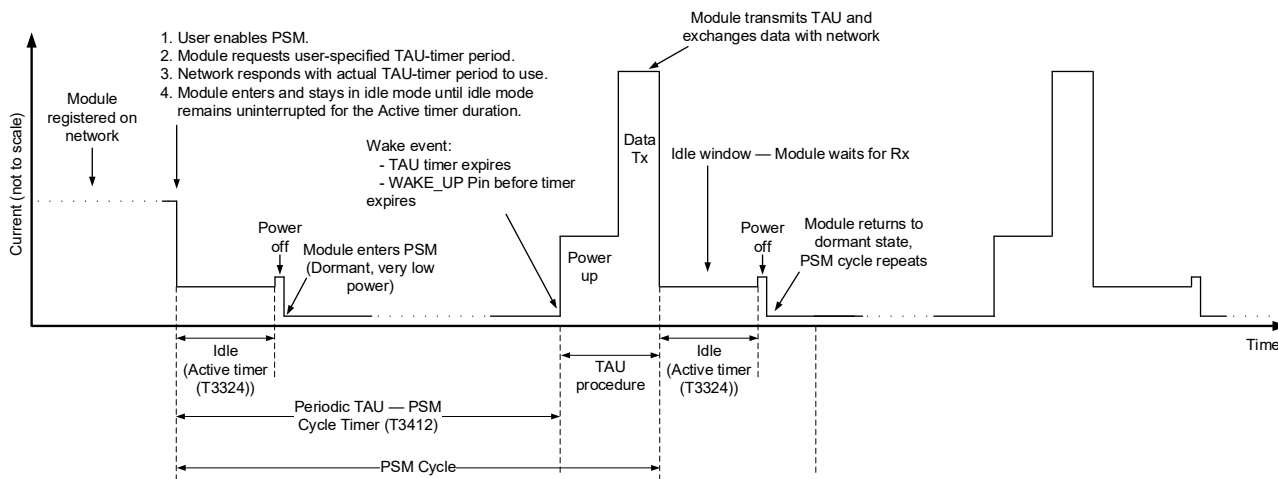

Figure 4. PSM Example (Simplified)

Note that:

- The PSM Periodic-TAU timer and Active Time values must be carefully selected to match the intended use case(s) for the module:
 - Periodic TAU PSM Cycle timer (T3412) – This is the maximum time the module can be away from the network (i.e. without a transmission). The module will automatically send a periodic TAU message to the network when this timer expires. If the module accesses the network (for example for mobile originated data) this timer would restart, and the module does not need to access the network for another T3412 duration. Typically, PSM should be used for applications that originate data from the module so the requested T3412 should be much longer than the expected period of the data originating from the module. Reducing the number of TAU will help reduce current consumption. Note that if the module were to fail to access the network within this time, the module would need to

reattach to the network. While the module is in PSM the network will not attempt to access the module.

- Active Time (T3324) – This is the duration of time that the module and the network are to be idle (without sending/receiving any data) to trigger the module to enter PSM state. This timer starts when the module enters idle state and will restart when there are any data transfers (to/from module). If the module/network do not send any data for T3324 period, the module will enter PSM state. The intent of this timer is to allow for a period of time for the module and the network server to communicate. The value of this timer should be selected to match the expected module to/from network server packet delays (using shorter durations would save more current).
- While it may be possible to set a large Active Time (T3324) such that mobile terminated access after a TAU is possible, it may be difficult to reliably send data to the UE as the exact time of the TAU may vary. Instead, the module application should periodically poll the network server if the module is to be accessible. With this approach a shorter Active Time (T3324) can be used and a longer periodic TAU time (T3412) – the timing of when the module is accessible is also more accurate. The polling packet sent by the module would use a similar amount of current as a TAU. It is recommended to use eDRX (as described in the next section) instead of PSM if the module needs to be truly accessible.
- When using multiple devices, consider scheduling the modules to wake at different times so that the network does not get flooded by all modules waking and transmitting simultaneously.

3.3.1.2. Extended DRX (eDRX)

Extended Idle DRX (I-eDRX) is a 3GPP specified feature that reduces the number of Paging Occasions (PO) that the module needs to monitor. Many data module applications are tolerant to delays in downlink data packets so extending the paging cycle would allow for current consumption savings for these applications. The HL7800 and HL7800-M support eDRX and can take advantage of the feature by entering a low power state between the eDRX cycles. The periodicity of the eDRX cycles (T_{I-eDRX}) and the duration of the Paging Transmission Window (PTW) are shown in the diagram below. The module application can negotiate specific eDRX parameter values with the network.

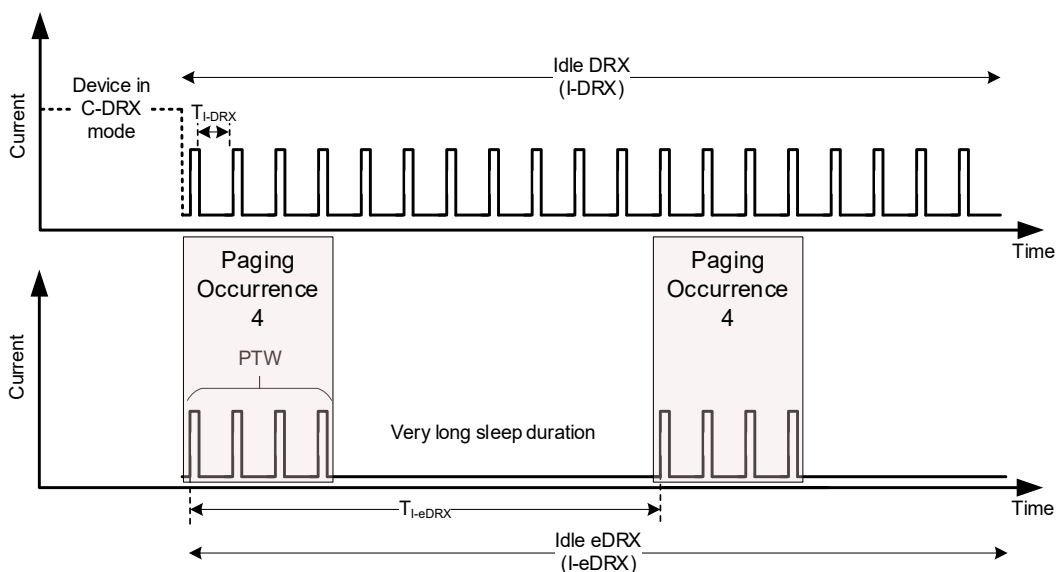

Figure 5. eDRX Example (PTW: 4 Paging Occurrences)

The HL7800 and HL7800-M enter a very low current consumption state between eDRX cycles. However, for short period of time right after the module enters idle state, the module will have a few extra short wake ups for clock calibration (shorter than an eDRX monitor). The following figure shows

an eDRX power consumption profile with a periodic TAU event. Notice that after the TAU, the eDRX 81.92s cycle is restored slowly by several iterations from 10s to 20s then to 40s before reaching the 81.92s wake. This behavior is mandatory by design and cannot be avoided.

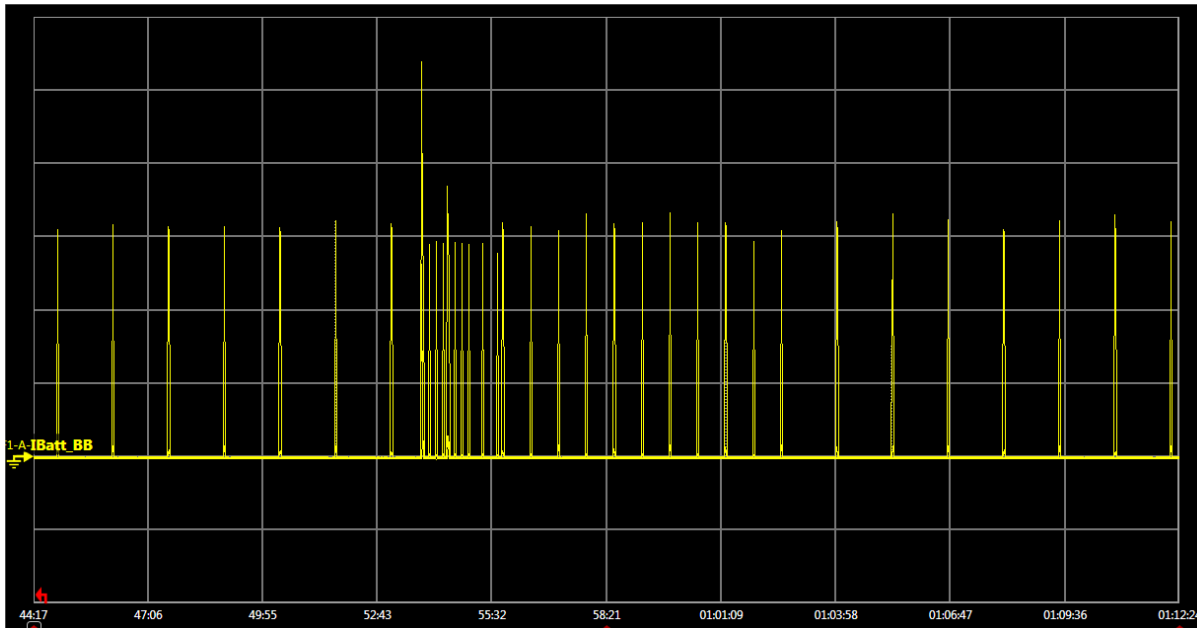

Figure 6. eDRX Power Consumption Profile Interruption

The following table describes available methods for configuring eDRX.

Table 14. eDRX-Related Commands

AT Command	Description
AT+CEDRXS	Enable/disable eDRX and configure related settings
AT+CEDRXRDP	Display current eDRX settings

For example:

- Use the **AT+CEDRXS** command to configure the desired T_{I-eDRX} value.
- During the network attach or TAU process:
 - eDRX request with the settings (as specified in AT+CEDRXS) is sent to the network.
 - Network responds if the UE may use eDRX and the eDRX parameters that should be used. The network may adjust the eDRX parameters from those requested by the UE.
- If eDRX is accepted by the network, the UE will only need to monitor during the eDRX paging occurrences. The UE may enter low power mode state between the eDRX paging occurrences (depending on the UE configuration).

Note that:

- The eDRX parameters must be carefully selected to match the intended use case(s) for the module. The module can only be paged at an eDRX paging occasion, hence, longer eDRX cycles will delay mobile terminated data reception. Selecting shorter eDRX cycles will reduce the latency but if the eDRX cycles are too short then there will be lower power savings. The duration of the eDRX cycle should be appropriately selected for the specific use case.
- Network-side store and forward is supported – Packets will be stored until the module’s next eDRX paging occurrence.

3.3.1.3. Possible Concurrent Modes

These two modes may run concurrently in a future firmware release; that is, eDRX may be performed during the active window of PSM.

For example, for a PSM of one day (T3412 of 86400s) with an active window (T3324) of 5 minutes (300s), the module may be in an eDRX power saving mode of 82s for 3 cycles then sleep for 23h55 until the next TAU during the 5-minute active window.

3.3.2. Power Modes

In addition to the 3GPP power saving features, several low power modes are defined for the AirPrime HL7800 and HL7800-M modules. There are three power modes defined, as follows:

- Sleep mode: 26Mhz system clock is OFF, all memories and I/O states are retained. The module can wake-up via the WAKE_UP signal or UART1_DTR.
- Lite Hibernate mode: RTC, I/O states and a part of the RAM are ON (RAM is only used for 4G protocol state and data). The module can wake-up via the WAKE_UP signal or UART1_DTR.
- Hibernate mode: RTC and optionally part of the RAM (depending on the 4G modem state) are ON. The module can only wake-up only via the WAKE_UP signal. (All I/Os are in undefined state.)

These modes can be configured using the **+KSLEEP** AT command.

Note that:

- When the module exits from Lite Hibernate or Hibernate mode, the host processor will act as after a module reset (all non-persistent configurations are lost).
- Sleep mode is recommended for regular DRX mode.
- Hibernate mode is recommended when the module is configured in PSM or eDRX mode.

The table below summarizes these low power modes.

Table 15. Low Power Modes

Power Mode	Possible Modem State	I/O State	Hardware Wake-Up Signal Source
Sleep	Stack OFF, DRX, eDRX, PSM, No service	Retained	UART1_DTR WAKE_UP
Lite Hibernate	Stack OFF, eDRX, PSM, No service	Retained	UART1_DTR WAKE_UP
Hibernate	Stack OFF, eDRX, PSM	Not retained	WAKE_UP

Warning: *If USB_VBUS is connected, it will not be possible to enter Lite Hibernate or Hibernate mode.*

Refer to document [4] AirPrime HL7800 Low Power Modes Application Note for additional details, especially on the relationship between 3GPP power saving features and the HL7800 and HL7800-M power modes. Additionally, refer to document [5] AirPrime HL7800-M MNO and RF Band Customization at Customer Production Site Application Note for band selection details since it impacts power consumption.

3.3.3. Digital I/O during Hibernate Power Mode

The following behavior are only applicable to digital I/Os in Hibernate mode in eDRX and PSM; it is not applicable when in Lite Hibernate or Sleep mode.

- VGPI0 is OFF.
- No I/O should be biased as no internal source exists. The maximum allowed voltage is $\pm 0.2V$ at any I/O.
- All I/Os referenced to VGPI0 are undefined.
- All I/Os referenced to VGPI0 are restored to their state at every wake; that also includes their reset state as described in Table 5 Pin Definition.

For example, if an I/O has a low state before entering Hibernate mode but has a PU state during reset, the I/O state will be undefined during Hibernate mode and then will be high due to the PU during the few hundred ms reset mode and then restored at its low level; this happens at every wake cycle of hibernate mode.

The behavior described above generates a toggling of various I/Os like the UART lines and the GPIOs during the Hibernate mode and can result in unwanted I/O activity from the host processor's point of view.

Every line referenced to VGPI0 as described in section 2 Pad Definition is affected by this behavior.

3.3.3.1. In PSM Mode

VGPIO and I/O (with Pull Up by default) are both high for 34.9 s corresponding to the TAU procedure + 30s of activity window, time duration while the module can be reach from the network (T3324).

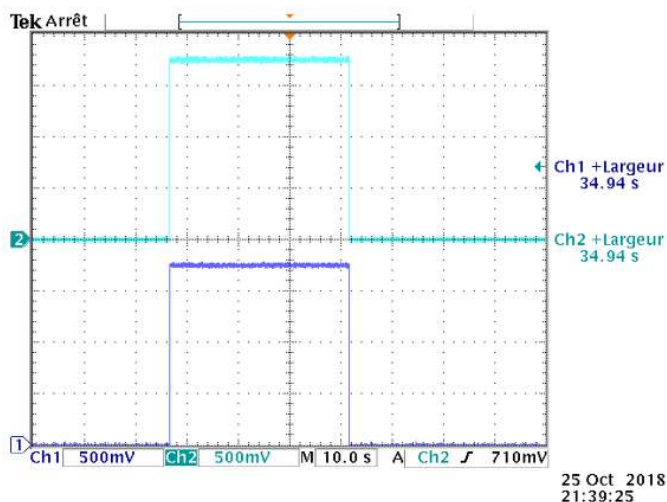

Figure 7. PSM I/O Toggling during TAU and the Active Window (T3324)

3.3.3.2. In eDRX Mode

At every eDRX paging wake, the VGPIO is present and so is any GPIO (with Pull Up by default). In the figure below, the eDRX cycle is 20s of sleep and 1.024s of activity.

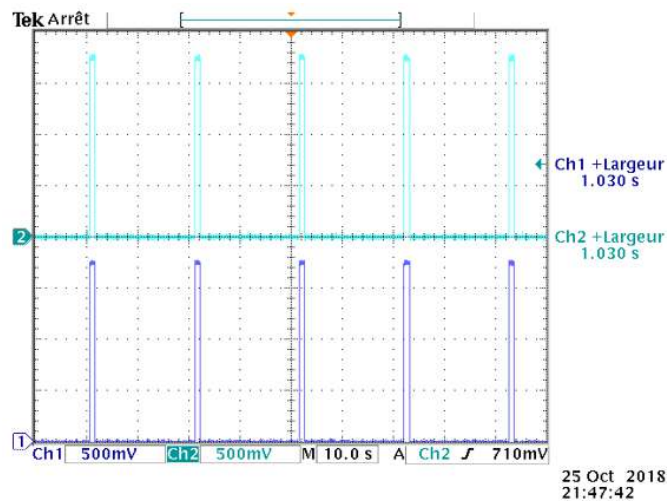

Figure 8. eDRX Cycle of 20s sleep and 1.024s of Activity

For eDRX cycles of 81.92 s or longer, that is a 10-minute internal calibration period that repeats at every TAU cycle. In this case, the eDRX wakes are added to the internal calibration wakes and results in thin extra wakes of VGPIO that results in I/O toggling. This may influence the application processor or customers' interface. Also, these thin internal calibration wakes (that lasts for 10 minutes) repeat every 10 seconds, then every 20 s, then every 40 s before reaching the final 80 seconds wake.

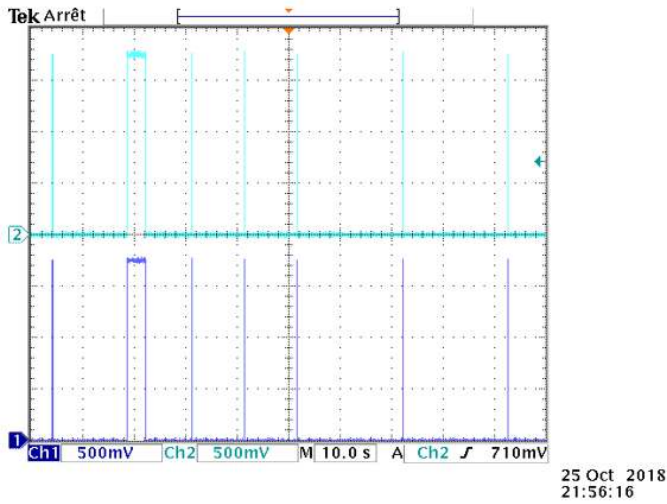

Figure 9. eDRX with Extra Calibration Wakes

Eventually, a stable eDRX wake repeats every cycle without extra wakes. In the following figure, a PTW of 1.02 is used with a cycle of 81.92s.

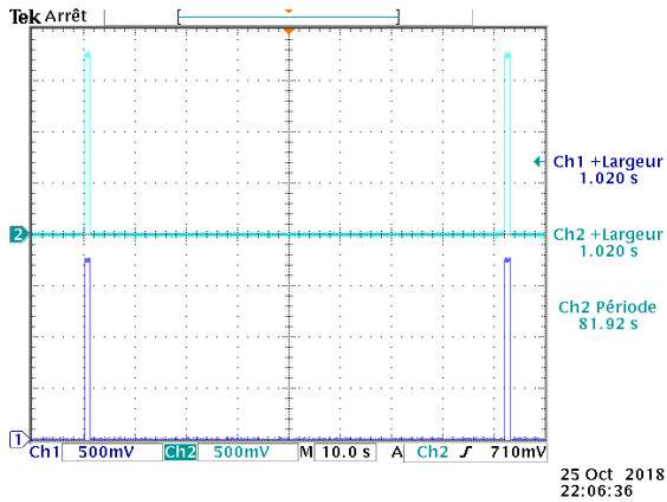

Figure 10. Stable eDRX Cycle of 81.92s after Calibration

3.4. VGPIO

The VGPIO output can be used to:

- Pull-up signals such as I/Os.
- Supply the digital transistors driving LEDs.

The VGPIO output is available when the module is switched ON. Note that VGPIO is OFF during Hibernate mode.

Refer to the following table for the pin description of the VGPIO interface.

Table 16. VGPIO Pin Description

Pad Number	Signal Name	I/O	Description
C45	VGPIO	O	GPIO voltage output

Refer to the following table for the electrical characteristics of the VGPIO interface.

Table 17. VGPIO Electrical Characteristics

Parameter	Minimum	Typical	Maximum	Remarks
Voltage level (V)	1.7	1.8	1.9	Applies to Active, Sleep, and Lite Hibernate modes. VGPIO is turned off during Hibernate mode.
Current capability Active Mode (mA)	-	-	50	The total current from all I/Os combined, and supplied by VGPIO, should not exceed 50 mA.
Current capability Sleep Mode (mA)			1	
Rise Time (ms)	-	-	0.5	Start-Up time from 0V

3.5. Real Time Clock (BAT_RTC)

Note: This interface will be available in a future firmware release.

The AirPrime HL7800 and HL7800-M modules provide an input to connect a Real Time Clock power supply.

This pin is used as a back-up power supply for the internal Real Time Clock. The RTC is supported when VBATT is available but a back-up power supply is needed to save date and hour when VBATT is switched off.

This pin is input only and is not capable of charging a backup capacitor.

Table 18. BAT_RTC Electrical Characteristics

Parameter	Minimum	Typical	Maximum	Unit
Input voltage	2.2	-	4.35	V
Input current consumption	-		10	μA

3.6. USIM Interface

The AirPrime HL7800 and HL7800-M modules have one physical USIM interface, USIM1, and an optional internal USIM or eUICC.

The USIM1 interface allows control of a 1.8V USIM (3V not supported) and is fully compliant with GSM 11.11 recommendations concerning USIM functions.

The five signals used by this interface UIM1 are as follows:

- UIM1_VCC: Power supply
- UIM1_CLK: Clock
- UIM1_DATA: I/O port
- UIM1_RESET: Reset
- UIM1_DET/GPIO3: Hardware SIM detection

Refer to the following table for the pad description of the USIM1 interface.

Table 19. USIM1 Pin Description

Pad Number	Signal Name	Description	Multiplex
C26	UIM1_VCC	1.8V USIM1 Power supply	
C27	UIM1_CLK	1.8V USIM1 Clock	
C28	UIM1_DATA	1.8V USIM1 Data	
C29	UIM1_RESET	1.8V USIM1 Reset	
C64	UIM1_DET	1.8V USIM1 Detection	GPIO3

Refer to the following table for the electrical characteristics of the USIM1 interface.

Table 20. USIM1 Electrical Characteristics

Parameter	Minimum	Typical	Maximum	Remarks
UIM1 Interface Voltage (V) (VCC, CLK, I/O, RESET)	-	1.80	-	The appropriate output voltage is auto detected and selected by software.
UIM1 Detect	-	1.80	-	High active
UIM1_VCC Current (mA)	-	-	50	Max output current in sleep mode = 3 mA
UIM1_VCC Power-up Setting Time (μ s) from power down	-	10	-	

3.6.1. UIM1_DET

Note: This interface will be available in a future release.

UIM1_DET is used to detect and notify the application about the insertion and removal of a USIM device in the USIM socket connected to the main USIM interface (UIM1). When a USIM is inserted, the state of UIM1_DET transitions from logic 0 to logic 1. Inversely, when a USIM is removed, the state of UIM1_DET transitions from logic 1 to logic 0.

Enabling or disabling this USIM detect feature can be done using the **AT+KSIMDET** command. For more information about this command, refer to document [2] AirPrime HL78xx AT Commands Interface Guide. (Note that this command is not yet available.)

3.7. USB Interface

The AirPrime HL7800 and HL7800-M modules have one Universal Serial Bus Interface Full Speed. Refer to the following table for the pad description of the USB interface.

Table 21. USB Pin Description

Pad Number	Signal Name	I/O	Function
C12	USB_D-	I/O	USB Data Negative
C13	USB_D+	I/O	USB Data Positive
C16	USB_VBUS	I	USB VBUS

Refer to the following table for the electrical characteristics of the USB interface.

Table 22. USB Electrical Characteristics

Parameter	Minimum	Typical	Maximum	Unit
Input voltage at pins USB_D+ / USB_D-	3.15	3.3	3.45	V
USB_VBUS	4.75	5.0	5.25	V

Note: USB_VBUS is a mandatory connection to supply the USB interface.

When USB is used, the lowest power mode supported is Sleep mode.

USB_VBUS must not be connected if Hibernate or Lite Hibernate mode is used.

3.8. Electrical Information for Digital I/O

The table below enumerates the electrical characteristics of the following digital interfaces.

- UART
- PCM
- GPIOs
- FAST_SHUTDOWN_N
- EXT_LNA_GPS_EN

Table 23. Digital I/O Electrical Characteristics

Parameter	Description	Minimum	Typical	Maximum	Unit
V _{IH}	Logic High Input Voltage	0.7 x VGPIO		**	V
V _{IL}	Logic Low Input Voltage	**		0.3 x VGPIO	V
V _{OH}	Logic High Output Voltage	0.8 x VGPIO			V
V _{OL}	Logic Low Output Voltage			0.2 x VGPIO	V
I _O *	I/O Drive Strength	2		4	mA
I _{IH}	Input current in Pull Down	+10	+35	+45	μA
I _{IL}	Input Current in Pull up	-10	-35	-45	μA
R _{PU}	Internal Pull-Down Resistor	13	50	65	KΩ
R _{PD}	Internal Pull-Up Resistor	13	50	65	KΩ

* The total current from all I/Os combined, and supplied by VGPIO, should not exceed 50mA.

** The maximum voltage allowed on digital I/O is ±0.2V during Hibernate mode.

3.9. General Purpose Input/Output (GPIO)

The AirPrime HL7800 and HL7800-M modules provide 12 GPIOs, 3 of which are multiplexed.

The following table describes the pin description of the GPIO interface.

Table 24. GPIO Pin Description

Pad Number	Signal Name	Multiplex	I/O	Power Supply Domain
C1	GPIO1		I/O	1.8V
C10	GPIO2		I/O	1.8V
C40	GPIO7		I/O	1.8V
C41	GPIO8	VBATT_PA_EN	I/O	1.8V
C46	GPIO6		I/O	1.8V
C51	GPIO14		I/O	1.8V
C52	GPIO10		I/O	1.8V
C53	GPIO11		I/O	1.8V
C54	GPIO15		I/O	1.8V
C64	GPIO3	UIM1_DET	I/O	1.8V
C65	GPIO4*	FAST_SHUTDOWN_N	I/O	1.8V
C66	GPIO5		I/O	1.8V

* GPIO4 will be available in a future release.

3.10. Main Serial Link (UART1)

The main serial link (UART1 up to 921.6Kbps) is used for communication between the module and a PC or host processor. It consists of a flexible 8-wire serial interface that complies with RS-232 interface. The main serial link (UART1) is an asynchronous serial interface; and is also used to upgrade the firmware locally.

If possible, it is highly recommended to add 0Ω on every line to help the debug process. This will force the UART signal layout to the top PCB layer and allow access to the signal on the resistors.

The signals used by UART1 are as follows:

- TX data (UART1_TX)
- RX data (UART1_RX)
- Request To Send (UART1_RTS)
- Clear To Send (UART1_CTS)
- Data Terminal Ready (UART1_DTR)
- Data Set Ready (UART1_DSR)
- Data Carrier Detect (UART1_DCD)
- Ring Indicator (UART1_RI)

Note: Signal names are according to PC view.

Refer to the following table for the pin description of the main serial link (UART1) interface.

Table 25. UART1 Pin Description

Pad Number	Signal Name*	I/O*	Description
C2	UART1_RI	O (active low)	Signal incoming calls (data only), SMS, etc.
C3	UART1_RTS	I (active low)	Request to send
C4	UART1_CTS	O (active low)	The module is ready to receive AT commands
C5	UART1_TX	I	Transmit data
C6	UART1_RX	O	Receive data
C7	UART1_DTR	I (active low)	Prevents the module from entering sleep mode, switches between data mode and command mode, and wakes the module up.
C8	UART1_DCD	O (active low)	Signal data connection in progress
C9	UART1_DSR	O (active low)	Signal UART interface is ON

* DTE (Data Terminal Equipment) convention, i.e. according to PC view.

Some customer applications require to wake-up its host processor with the RI signal after SMS or IP reception. When using eDRX mode in combination with Hibernate low power mode, this use case cannot be handled through the standard UART1_RI signal because it is active low and cannot remain high in Hibernate mode. In order to overcome this system issue, several GPIOs can be configured as an inverted RI signal (RI_inverse_gpio; refer to **AT+KRIC** in documents [2] AirPrime HL78xx AT Commands Interface Guide and [4] AirPrime HL7800 Low Power Modes Application Note for details.) GPIO2 is used by default for this function; however, all GPIOs with an internal Pull Down (see Table 5) can also be used with **AT+KRIC** (it is recommended to add an external 470kΩ PD to keep the I/O in a defined state during Hibernate mode).

3.10.1. 8-wire Application

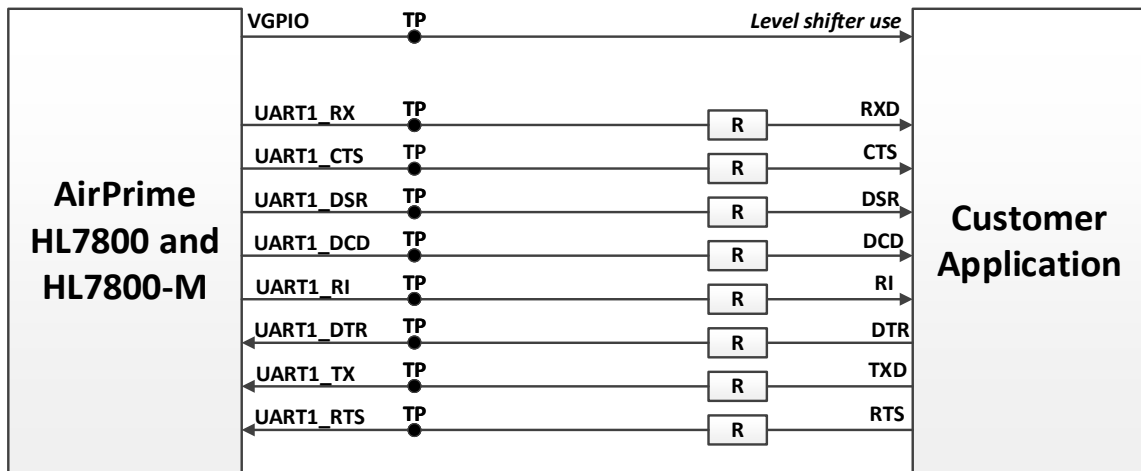

Note: R is a 0Ω resistor (default value)

Figure 11. 8-wire UART Application Example

3.10.2. 4-wire Application

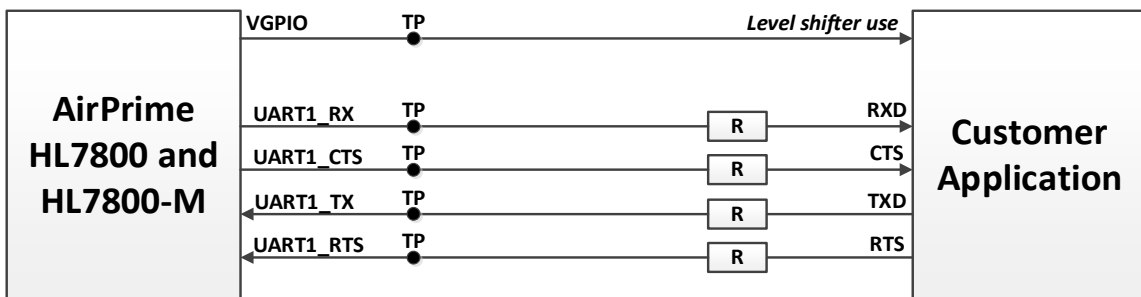

Note: R is a 0Ω resistor (default value)

Figure 12. 4-wire UART Application Example

3.10.3. 2-wire Application

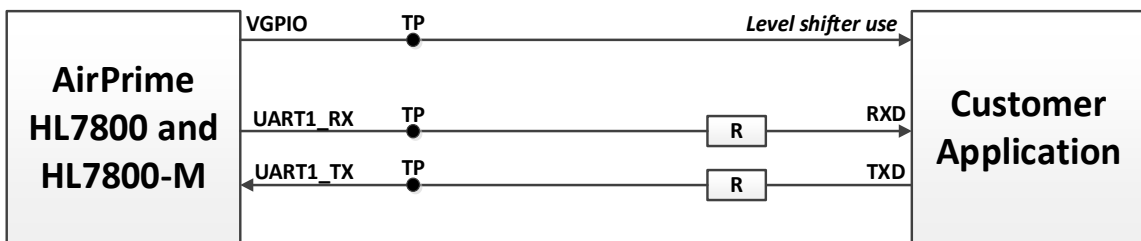

Note: R is a 0Ω resistor (default value)

Figure 13. 2-wire UART Application Example

3.11. Power On Signal (PWR_ON_N)

The PWR_ON_N signal is internally pulled-up. Once VBATT is supplied to the module, the internal supply regulator is enabled and so the PWR_ON_N signal is by default at high level.

In case the PWR_ON_N pin is not configured as managed by host (default configuration), the module starts regardless of the PWR_ON_N state. In case the RESET_IN_N signal is maintained low, the module will not start until RESET_IN_N is released.

In case the PWR_ON_N pin is configured as managed by host, a low-level signal must be provided to switch the module ON.

Table 26. PWR_ON_N Pin Description

Pad Number	Signal Name	I/O	Description
C59	PWR_ON_N	I	Powers the module ON

Table 27. PWR_ON_N Electrical Characteristics

Parameter	Minimum	Typical	Maximum
Input Voltage-Low (V)			0.3

Note: As PWR_ON_N is internally pulled up, an open collector or open drain transistor must be used for ignition.

VGPIO is an output from the module that can be used to check if the module is active.

- When VGPIO = 0V, the module is OFF (or in low power mode)
- When VGPIO = 1.8V, the module is ON (it can be in idle, communication or sleep mode)

Note: PWR_ON_N cannot be used to power the module off. To power the module off, use AT command **AT+CPOF** or the RESET_IN_N pin. Also, don't put the PWR_ON_N at low level or the WAKE_UP pin at high level during the power off sequence.

3.11.1. PWR_ON_N Not Managed (Default)

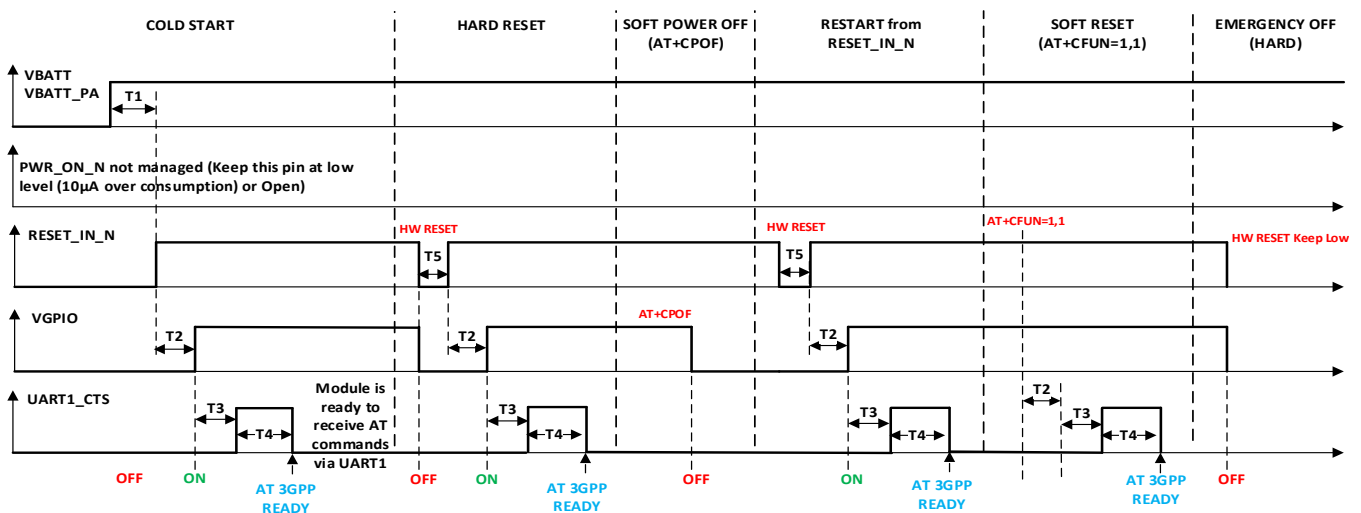

Figure 14. Power Up and Power Down Sequence without PWR_ON_N

Table 28. PWR_ON_N Not Managed Timing

Parameter	Minimum	Typical	Maximum*	Unit
T1: delay between VBATT and RESET_IN_N			1	ms
T2: delay between RESET_IN_N and VGPIO			5	ms
T3: delay between VGPIO and UART1_CTS			100	µs
T4: delay		8	10	s
T5: HW RESET delay	1			ms

* Any external capacitor or resistor added on the customer application will change these values.

3.11.2. PWR_ON_N Managed

Note: This interface will be available in a future firmware release.

3.11.2.1. First Power On

On the first battery connection, the first power on sequence (cold start) will appear one time after PWR_ON_N configuration via AT command. Refer to section 3.11.2.2 Power Up and Power Down after the First Cold Start for details.

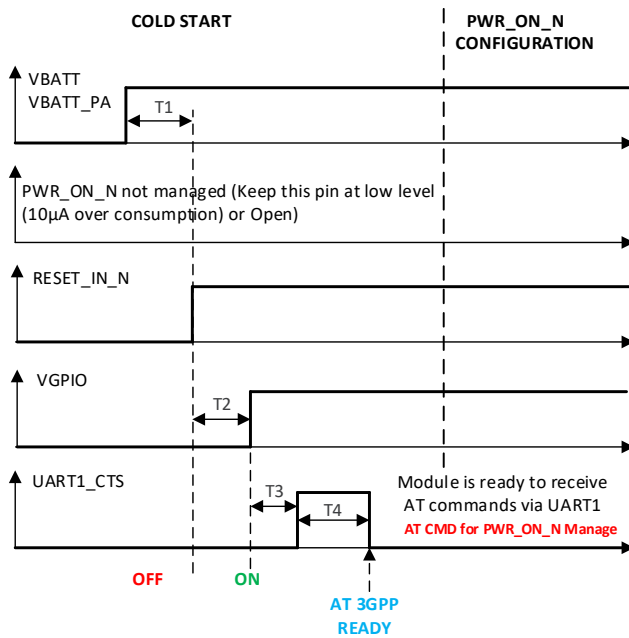
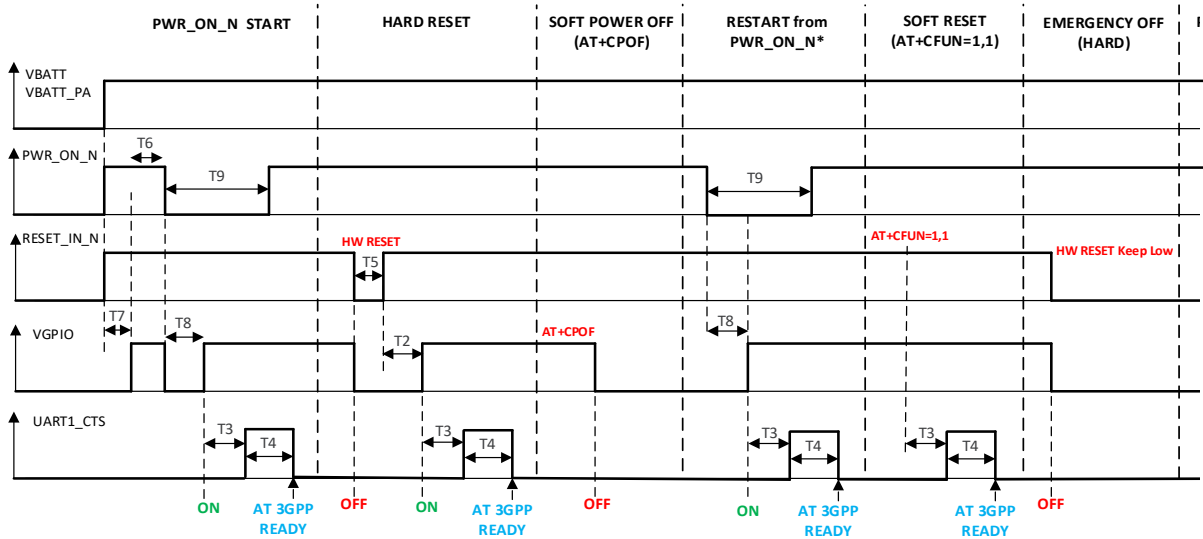

Figure 15. Power Up Sequence with PWR_ON_N Cold Start

3.11.2.2. Power Up and Power Down after the First Cold Start



* After AT+CPOF, the module can be woken up by either the PWR_ON_N or WAKE_UP pin

Figure 16. Power On Sequence with PWR_ON_N

3.11.2.3. Timing

Table 29. PWR_ON_N Managed Timing

Parameter	Minimum	Typical	Maximum*	Unit
T1: delay between VBATT and RESET_IN_N	0			ms
T2: delay between RESET_IN_N and VGPIO		5		ms
T3: delay between VGPIO and UART1_CTS			100	ms
T5: HW RESET delay	1			ms
T6: delay between VBATT and PWR_ON_N		100		ms
T7: delay between VBATT and VGPIO		5		ms
T8: delay between PWR_ON_N and VGPIO		5		ms
T9: PWR_ON_N assertion time	25		1500	ms

* Any external capacitor or resistor added on the customer application will change these values.

3.12. Reset Signal (RESET_IN_N)

To reset the module, a low-level pulse must be sent on the RESET_IN_N pad for at least 1 ms. This action will immediately restart the module. During reset, all I/Os will be undefined if no external signal is driven high (if the host processor drives some I/O high, a voltage leakage will appear on VGPIO and on all GPIOs with a pull-up).

Warning: It is forbidden to drive any I/Os during reset or Hibernate mode to high electrical level over 0.2V.

It is also forbidden to set RESET_IN_N low during a power recycle. VBATT must always be ≥ 3.2V when reset is at low level.

As RESET_IN_N is internally pulled up, an open collector or open drain transistor should be used to control this signal.

Refer to the following table for the pad description of the RESET_IN_N interface.

Table 30. RESET_IN_N Pin Description

Pad Number	Signal Name	I/O	Description
C11	RESET_IN_N	I	Reset signal

Refer to the following table for the electrical characteristics of the RESET_IN_N interface.

Table 31. RESET_IN_N Electrical Characteristics

Parameter	Minimum	Typical	Maximum
Input Voltage-Low (V)			0.3V
Reset assertion time (ms)	1 ms		

Note: As RESET_IN_N is internally pulled up, an open collector or open drain transistor must be used for ignition.

3.13. Analog to Digital Converter (ADC)

Two Analog to Digital Converter inputs, ADC0 and ADC1, are provided by AirPrime HL7800 and HL7800-M modules. These converters are 12-bit resolution ADCs ranging from 0 to 1.8V.

Typical ADC use is for monitoring external voltage, wherein an application is used to safely power OFF an external supply in case of overvoltage.

Refer to the following table for the pad description of the ADC interface.

Table 32. ADC Pin Description

Pad Number	Signal Name	I/O	Description
C24	ADC1	I	Analog to digital converter
C25	ADC0	I	Analog to digital converter

Refer to the following table for the electrical characteristics of the ADC interface.

Table 33. ADC Electrical Characteristics

Parameter	Minimum	Typical	Maximum	Unit	Remarks
ADCx Resolution	6		12	bits	
F _{CLK}	4	40	52	MHz	
F _s		F _{CLK} / (N+3)		MSPS	Conversion rate per channel*
Input Voltage Range		1.8		V	General purpose input
Integral Nonlinearity		± 1.0	± 2.0	LSB	
Differential Nonlinearity	± 1.0		± 1.0	LSB	

Parameter	Minimum	Typical	Maximum	Unit	Remarks
Offset Error		± 1.0	± 2.0	LSB	% FS
Gain Error		± 1.0	± 2.0	LSB	% FS
Input Resistance			0.5	KΩ	
Input Capacitance during sampling phase		2.6		pF	

* The general formula for this conversion rate is $FS = F_{CLK} / (N+3) / \text{number of sources}$.

3.14. Clock Interface

The AirPrime HL7800 and HL7800-M modules support two digital clock interfaces.

Enabling or disabling the clock out feature can be done using AT commands. For more information about AT commands; refer to document [2] AirPrime HL78xx AT Commands Interface Guide.

Refer to the following table for the pad description of the clock out interfaces.

Table 34. Clock Interface Pin Description

Pad Number	Signal Name	I/O	I/O Type	Description
C22	26M_CLKOUT	O	1.8V	26MHz Digital Clock output
C23	32K_CLKOUT	O	1.8V	32.768kHz Digital Clock output

3.15. PCM

Note: This interface will be available in a future release.

3.16. Debug Interfaces

The AirPrime HL7800 and HL7800-M modules provide two 4-wire debug port interfaces. The CLI interface and the Modem Logs interface can be used with the AT interface for full debug capability.

3.16.1. Command Line Interface (CLI)

Table 35. CLI Interface Pin Description

Pad Number	Signal Name*	I/O*	I/O Type	Description
C55	UART0_RX	O	1.8V	Debug Receive Data
C56	UART0_TX	I	1.8V	Debug Transmit Data
C57	UART0_CTS	O	1.8V	Debug Clear to Send
C58	UART0_RTS	I	1.8V	Debug Request to Send

* According to PC/host view.

Note: It is highly recommended to provide access through Test Points to this UART0 interface (required to enter in recovery mode; for example, for Flash dump).

3.16.2. Modem Logs interface

Table 36. Modem Logs Interface Pin Description

Pad Number	Signal Name*	I/O*	I/O Type	Description
C51	GPIO14	O	1.8V	UART3_CTS
C52	GPIO10	I	1.8V	UART3_TX
C53	GPIO11	I	1.8V	UART3_RTS
C54	GPIO15	O	1.8V	UART3_RX

* According to PC/host view.

Note: If there are no constraints on GPIO use, it is highly recommended to provide access through Test Points to these 4 GPIOs to access to the UART3 interface (required to debug modem logs).

3.17. Wake Up Signal (WAKE_UP)

The AirPrime HL7800 and HL7800-M modules provide one WAKE_UP signal.

The WAKE_UP pin is used to wake up the system from low power modes (from OFF, Sleep modes, FAST_SHUTDOWN, or after a software power off). This signal should be set to high level (external 1.8V) until the system is active to wake the module up from these modes.

The system will not be allowed to go into low power or off mode for as long as this signal is kept high.

By default, the software waits for a high state to wake up (100K Ω internal pull-down).

Refer to the following table for the pad description of the WAKE_UP signal.

Table 37. WAKE_UP Pin Description

Pad Number	Signal Name	I/O	I/O Type	Description
C44	WAKE_UP	I	1.8V	Wakes the module up from low power mode

Refer to the following table for the electrical characteristics of the WAKE_UP signal.

Table 38. WAKE_UP Electrical Characteristics

I/O Type	Parameter	Minimum	Typical	Maximum	Unit
Digital	V _{IL}			0.3	V
	V _{IH}	1.2			V

3.18. Fast Shutdown Signal (FAST_SHUTDOWN_N)

Note: This signal will be available in a future firmware release.

The AirPrime HL7800 and HL7800-M modules provide one Fast Shutdown signal, FAST_SHUTDOWN_N.

Refer to the following table for the pad description.

Table 39. FAST_SHUTDOWN_N Pin Description

Pad Number	Signal Name	I/O	I/O Type	Description
C65	FAST_SHUTDOWN_N	I	1.8V	Shuts the module down without deregistration from the network

Refer to the following table for the electrical characteristics of the FAST_SHUTDOWN_N signal.

Table 40. FAST_SHUTDOWN_N Electrical Characteristics

I/O Type	Parameter	Minimum	Typical	Maximum	Unit
Digital	V _{IL}			0.3xVGPI0	V
	V _{IH}	0.7 x VGPI0			V

* VGPI0 typical = 1.8 V.

3.19. RF Interface

The RF interface of the AirPrime HL7800 and HL7800-M modules allow the transmission of RF signals.

Contact Sierra Wireless technical support for assistance in integrating the AirPrime HL7800 or HL7800-M on applications with embedded antennas.

3.19.1. RF Connection

A 50Ω (with maximum VSWR 1.1:1, and 0.5dB loss) RF track is recommended to be connected to standard RF connectors such as SMA, UFL, etc. for antenna connection.

Refer to the following table for the pad description of the RF interface.

Table 41. RF Main Pin Description

Pad Number	RF Signal	Impedance	VSWR Rx (max)	VSWR Tx (max)
C48	GND			
C49	RF_MAIN	50Ω	2.5:1	2.5:1
C50	GND			

3.19.2. Maximum Output Power

The maximum transmitter output power of the AirPrime HL7800 and HL7800-M for all bands in normal operation conditions (25°C) is specified in the following table.

Table 42. Maximum Output Power

Minimum	Typical	Maximum	Units	Notes
21.5	23	24.5	dBm	Power class 3

3.19.3. Rx Sensitivity

The module's receiver sensitivity is specified in the following table. The test condition used for the following values are those defined in 3GPP TS36.521v13, as follows:

- Cat-M1: BW of 5 MHz, on Reference Measurement Channel
- NB1: on DL Reference Measurement Channel defined

Table 43. Typical Conducted Cat-M1 RX Sensitivity

LTE Band	Typical Reference Sensitivity Level @ 95% of the Maximum Throughput		
	@+25°C (dBm)	@Class A (dBm)	3GPP Limit (dBm)
B1	-105	-103.5	-102.3
B2	-105	-104	-100.3
B3	-106	-104.5	-99.3
B4	-105	-103.5	-102.3
B5	-106	-105	-100.8
B8	-106	-104	-99.8
B9	-106	-104.5	
B10	-105	-103.5	
B12	-106	-104.5	-99.3
B13	-106	-105	-99.3
B14	-106	-105	
B17	-106	-104.5	
B18	-106	-105	-100.3
B19	-106	-105	-102.3
B20	-106	-105	-99.8
B25	-106	-104	
B26	-106	-104.5	-100.3
B27	-106	-105.5	-100.8
B28	-106	-105	-100.8
B66	-105	-103.5	

Table 44. Typical Conducted NB1 RX Sensitivity

LTE Band	Typical Reference Sensitivity Level @ 95% of the Maximum Throughput		
	@+25°C (dBm)	@Class A (dBm)	3GPP Limit (dBm)
B1	-114	-112.5	-107.5
B2	-114.5	-113.1	-107.5
B3	-115	-113.5	-107.5
B4	-114	-112.6	-107.5
B5	-114.5	-113.3	-107.5
B8	-114	-112.8	-107.5
B9	NA	NA	NA
B10	NA	NA	NA
B12	-113.5	-112.2	-107.5
B13	-114	-112.8	-107.5
B14	-113.5	-112.3	-107.5
B17	-114	-112.7	-107.5
B18	-114.5	-113.2	-107.5
B19	-114.5	-113.2	-107.5
B20	-114	-112.7	-107.5
B25	-114	-112.7	-107.5
B26	-114.8	-113.5	-107.5
B27	NA	NA	NA
B28	-114	-112.7	-107.5
B66	-114	-112.5	-107.5

3.20. TX Indicator (TX_ON)

Note: This signal will be available in a future firmware release.

The AirPrime HL7800 and HL7800-M modules provide a signal, TX_ON, for TX emission indication.

Table 45. TX_ON Pin Description

Pad Number	Signal Name	I/O	I/O Type	Description
C60	TX_ON	O	1.8V	High during TX emission, low when there is no TX

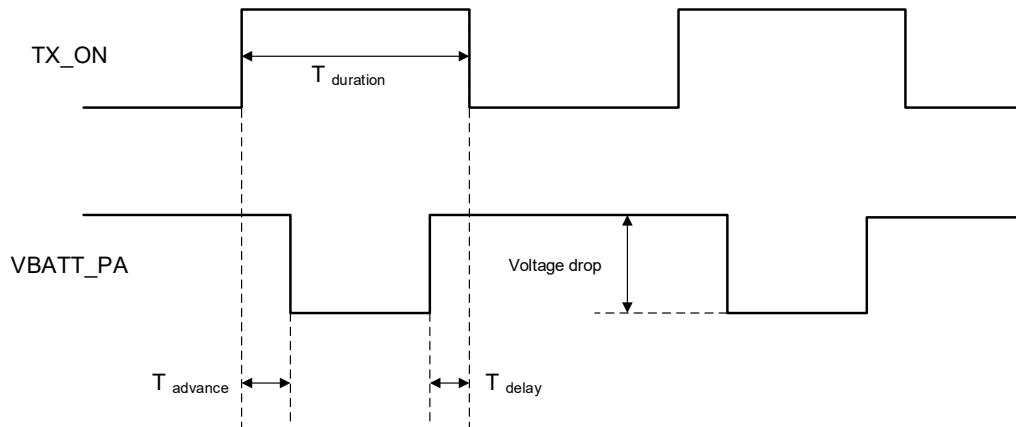

Figure 17. TX_ON State during TX Burst

3.21. External RF Voltage Control Indicator

Note: This signal will be available in a future firmware release.

The AirPrime HL7800 and HL7800-M modules provide a signal, VBATT_PA_EN, for RF activity indication. VBATT_PA_EN is used to drive an external LDO or DCDC that provides VBATT_PA power supply. It is recommended to add an external 470kΩ PD to keep the I/O in a defined state during Hibernate mode.

Table 46. VBATT_PA_EN Pin Description

Pad Number	Signal Name	I/O	I/O Type	Description
C41	GPIO8 / VBATT_PA_EN	O	1.8V	High when VBATT_PA is supplied, low if no power supply is required

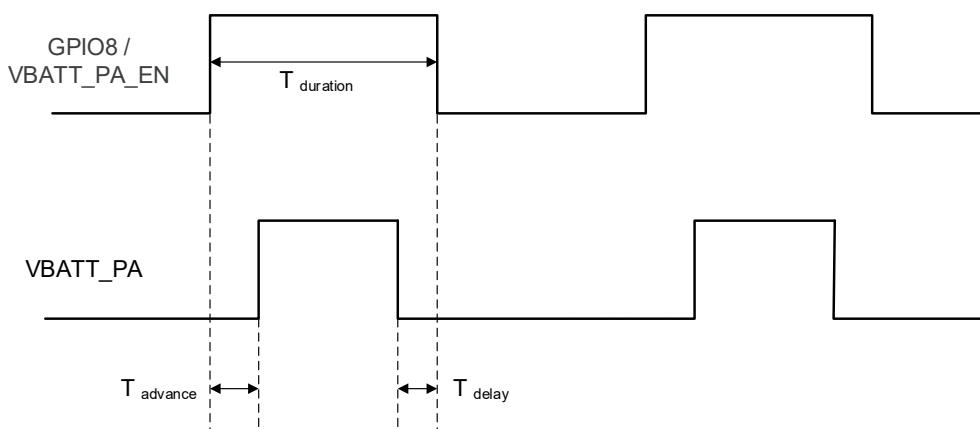

Figure 18. VBATT_PA_EN State during RX/TX windows

Table 47. VBATT_PA_EN Characteristics

Parameter	Typical*
T _{advance}	400 μ s
T _{delay}	400 μ s

* Typical values to be optimized in a future firmware release.

3.22. GPS Interface

Note: This interface will be available in a future release.

The AirPrime HL7800 and HL7800-M's GPS supports GPS L1 signal (1575.42 \pm 20 MHz) and GLONASS L1 FDMA signals (1597.5 – 1605.8 MHz), with 50 Ω connection on the RF_GPS pad.

Note: The GPS receiver shares the same RF resources as the 4G receiver. The end-device target should allow GPS positioning for asset management applications where infrequent and no real-time position updates are required.

GPS antenna interface specifications are defined in the table below.

Table 48. GPS Antenna Specifications

Characteristics	Value
Frequency (MHz)	GPS L1 1575.42 \pm 20
RF Impedance (Ω)	50
VSWR max	2:1

3.22.1. GPS Performance

Refer to the following table for GPS performance details.

Table 49. GPS Performance

Parameters	Conditions	Typical Value
Sensitivity	Cold Start	-146dBm
	Hot Start	-152dBm (TBC)
	Tracking	-161dBm
TTFF	Cold start, Input power -130dBm	40s
	Hot start, Input power -130dBm	2s (TBC)
2D Position Error	Input power -130dBm	2.5m

3.22.2. GPS Antenna Indicator (EXT_LNA_GPS_EN)

Note: This signal will be available in a future firmware release.



4. Mechanical Drawings

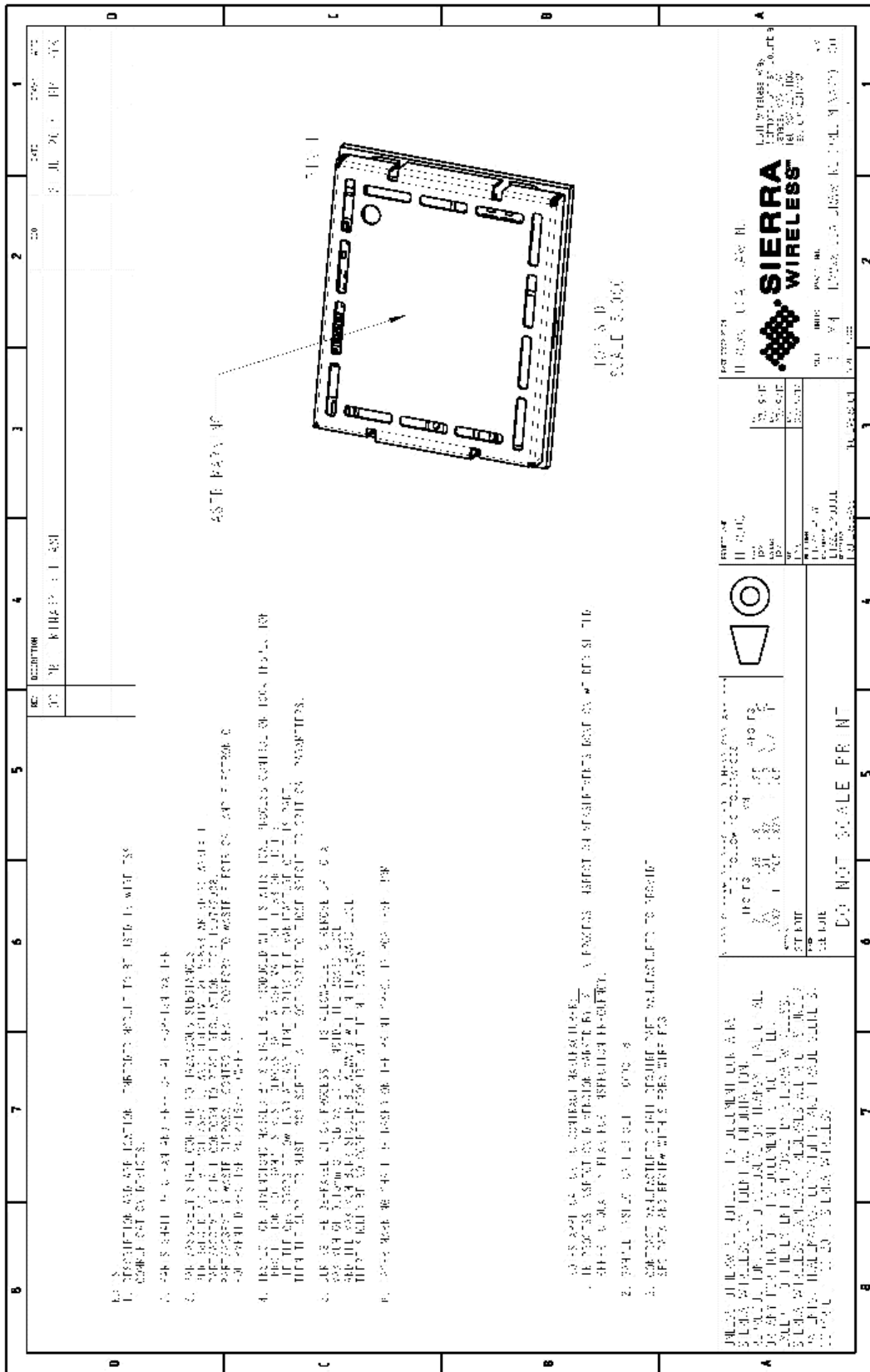

Figure 19. Mechanical Drawing

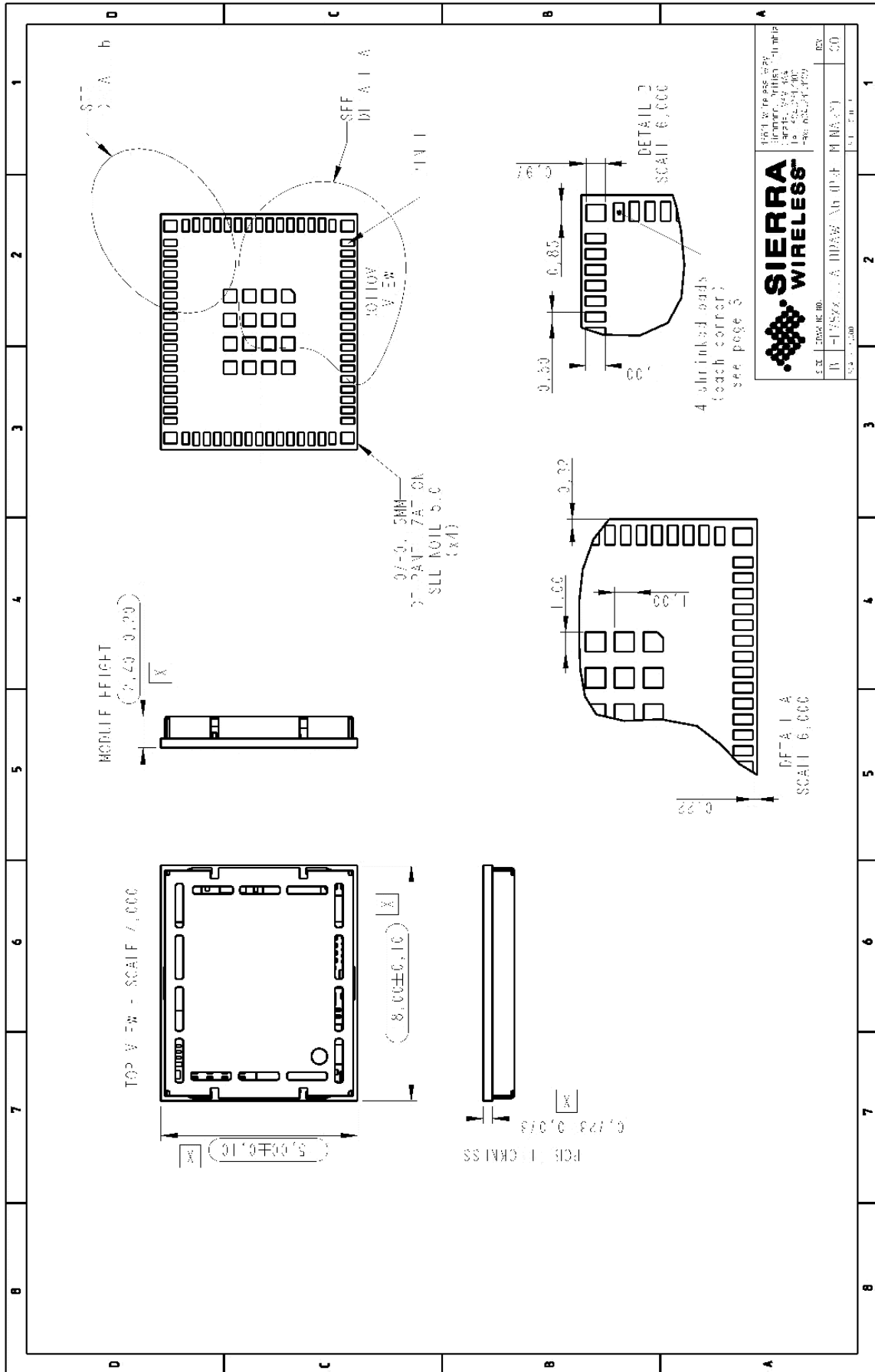

Figure 20. Dimensions Drawing

5. Design Guidelines

5.1. Power Supply Design

The AirPrime HL7800 and HL7800-M should not be supplied with voltage over 4.35V, even temporarily or however briefly.

If the system's main board power supply unit is unstable or supplied with voltage over 4.35V, even in the case of transient voltage presence on the circuit, the module's power amplifier may be severely damaged.

To avoid such issues, add a voltage limiter to the module's power supply lines so that VBATT and VBATT_PA signal pads will never receive a voltage surge over 4.35V. The voltage limiter can be as simple as a Zener diode.

5.2. Power Cycle

In addition to Sierra Wireless' reliable recovery mechanisms, it is highly recommended that the ability for a power cycle to reboot the module be included in the design in case the module becomes blocked and stops responding to reset commands.

5.3. ESD Guidelines for USIM

Decoupling capacitors must be added according to the drawings below as close as possible to the USIM connectors on UIM1_CLK, UIM1_RST, UIM1_VCC, UIM1_DATA and UIM1_DET signals to avoid EMC issues and to comply with the requirements of ETSI and 3GPP standards covering the USIM electrical interface.

A typical schematic including USIM detection is provided below.

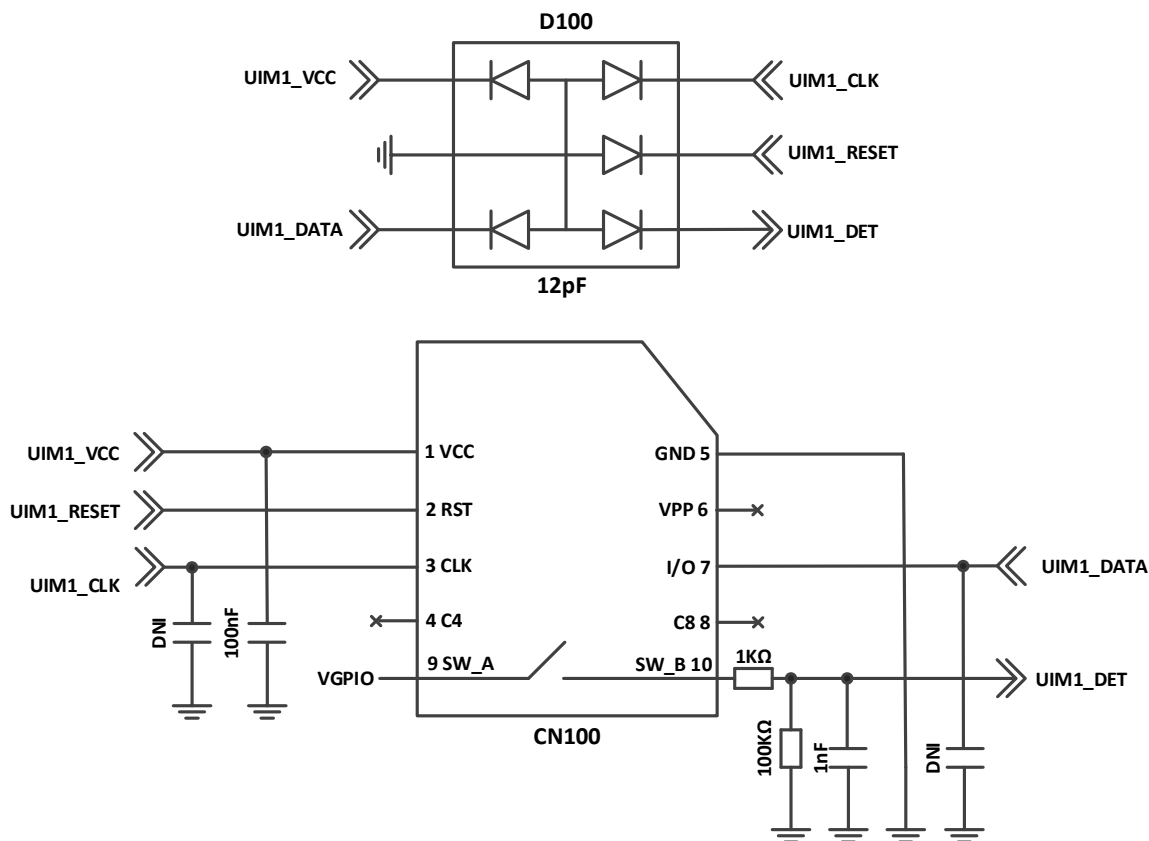

Figure 22. EMC and ESD Components Close to the USIM

Sierra Wireless recommends using diode ESDALC6V1-5P6 ESD for D100.

5.4. ESD Guidelines for USB

When the USB interface is externally accessible, it is required to have ESD protection on the USB_VBUS, USB_D+ and USB_D- signals.

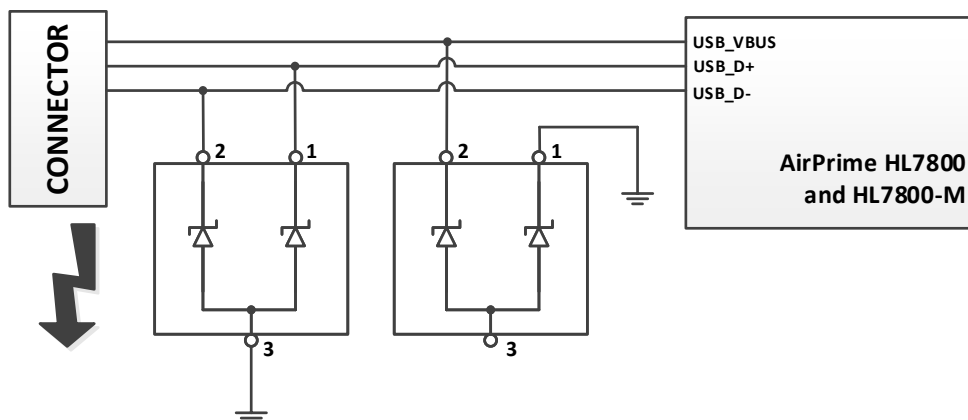

Figure 23. ESD Protection for USB

Note: It is not recommended to have an ESD diode with feedback path from USB_VBUS to either USB_D+ or USB_D-.

Sierra Wireless recommends using ESD diode RCLAMP0503N or ESD5V3U2U-03LRH.

5.5. Radio Frequency Integration

The AirPrime HL7800 and HL7800-M are equipped with an external antenna. A 50Ω line matching circuit between the module, the customer’s board and the RF antenna is required as shown in the example below.

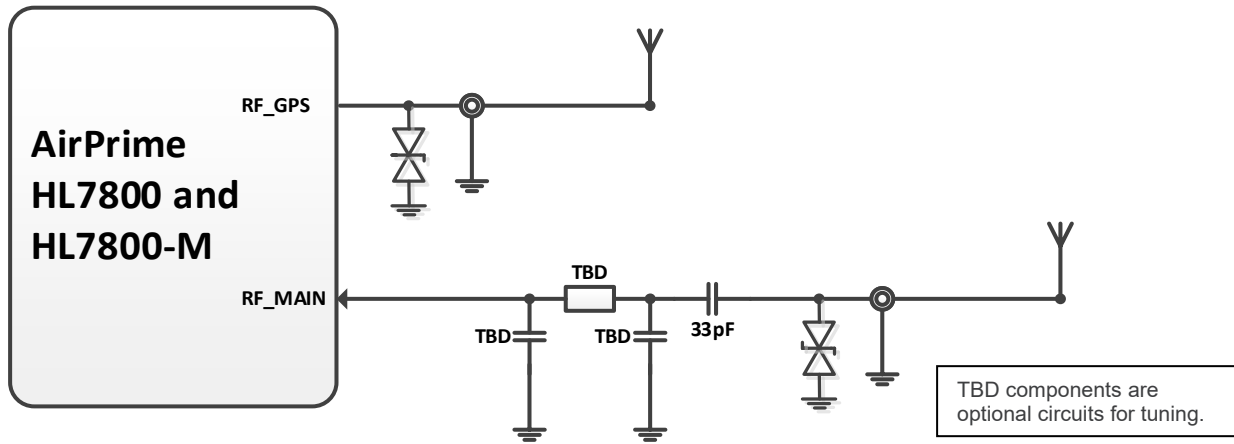

Figure 24. Antenna Connection

Sierra Wireless recommends using ESD diode ESD103-B1-02EL E6327 for RF_MAIN and ESD8011MUT5G for RF_GPS.

Note: The (optional) antenna detection circuit will be available in a future release.



6. Reliability Specification

The AirPrime HL7800 and HL7800-M modules will be tested against the Sierra Wireless Industrial Reliability Specification defined below.

6.1. Preconditioning Test

Per JESD22A113, this test the preconditioning of non-hermetic surface mount devices prior to reliability testing.

Table 50. Preconditioning Test

Designation	Condition
Preconditioning Test PCRM	2 reflow cycles with Tmax 245-250°C



6.2. Performance Test

Table 51. Performance Test

Designation	Condition
Performance Test PT3T & PTRT 	Standard: N/A
	Special conditions: <ul style="list-style-type: none">• Temperature:<ul style="list-style-type: none">▪ Class A: -30°C to +70°C▪ Class B: -40°C to +85°C▪ Rate of temperature change: ± 3°C/min• Recovery time: 3 hours
	Operating conditions: Powered
	Duration: 14 days

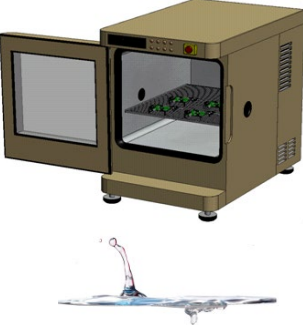

6.3. Aging Tests

Table 52. Aging Tests

Designation	Condition
<p>High Temperature Operating Life test HTOL</p> 	<p>Standard: IEC 680068-2-2, Test Bb</p> <p>Special conditions:</p> <ul style="list-style-type: none"> • Temperature: +85°C • Temperature variation: 1°C/min <p>Operating conditions: Powered ON with a power cycle of 45 minutes ON and 15 minutes Idle</p> <p>Duration: 20 days</p>
<p>Thermal Shock Test TSKT</p> 	<p>Standard: IEC 60068-2-14, Test Na</p> <p>Special conditions:</p> <ul style="list-style-type: none"> • Temperature: -40°C to +85°C • Temperature Variation: less than 30s • Number of cycles: 300 • Dwell Time: 10 minutes <p>Operating conditions: Un-powered</p> <p>Duration: 7 days</p>
<p>Humidity Test HUT</p> 	<p>Standard: IEC 60068-2-3, Test Ca</p> <p>Special conditions:</p> <ul style="list-style-type: none"> • Temperature: +85°C • RH: 85% <p>Operating conditions: Powered on, DUT is powered up for 15 minutes and OFF for 15 minutes</p> <p>Duration: 10 days</p>

6.4. Characterization Tests

Table 53. Characterization Tests

Designation	Condition
Low Temperature and Cold Start Cycles LTCS	Special conditions: <ul style="list-style-type: none"> • Temperature: -40°C • AT commands read or write memory
	Operating conditions: 5 mins powered ON, 30 mins powered OFF (1 power cycle)
	Duration: 5 days
Component Solder Wettability CSW 	Standard: JESD22 – B102, Method 1/Condition C, Solderability Test Method
	Special conditions: <ul style="list-style-type: none"> • Test method: Surface mount process simulation test (preconditioning 16 h ±30 minutes dry bake)
	Operating conditions: Un-powered
	Duration: 1 day
Unprotected Free Fall Test FFT 1 	Standard: IEC 60068-2-32, Test Ed
	Special conditions: <ul style="list-style-type: none"> • Number of drops: 6 drops per unit (1 drop per direction: ±X, ±Y, ±Z) • Height: 1m
	Operating conditions: Un-powered
	Duration: 1 day

>> 7. Legal Information

7.1. Japan Radio and Telecom Approval

The end device embedding the AirPrime HL7800 or HL7800-M should affix the certification indication on its surface following the recommendations below:

- The diameter of the Japan Approval mark must be 3mm or bigger.
- The size, font and color of the Radio Certification Type number is not regulated but should be easily distinguished.

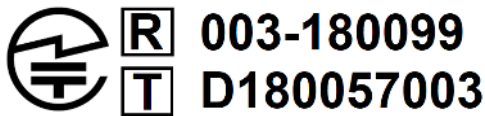

Figure 25. Sample Japan Certification Indication

7.2. Korean Approval

The end device embedding the AirPrime HL7800 or HL7800-M should affix the certification indication on its surface following the recommendations below:



Figure 26. Sample Korean Approval

7.3. FCC Statement

This device complies with part 15 of the FCC Rules. Operation is subject to the following two conditions:

1. This device may not cause harmful interference, and
2. this device must accept any interference received, including interference that may cause undesired operation.

Any changes or modifications not expressly approved by the party responsible for compliance could void the user's authority to operate this equipment.

This transmitter must not be co-located or operating in conjunction with any other antenna or transmitter.

7.3.1. Radiation Exposure Statement

This equipment complies with FCC radiation exposure limits set forth for an uncontrolled environment. This equipment should be installed and operated with minimum distance 20 cm between the radiator and your body.

This device is intended only for OEM integrators under the following conditions:

1. The antenna must be installed such that 20 cm is maintained between the antenna and users, and
2. The transmitter module may not be co-located with any other transmitter or antenna.

As long as the 2 conditions above are met, further transmitter test will not be required. However, the OEM integrator is still responsible for testing their end-product for any additional compliance requirements required with this module installed.

IMPORTANT NOTE: In the event that these conditions cannot be met (for example certain laptop configurations or co-location with another transmitter), then the FCC authorization is no longer considered valid and the FCC ID cannot be used on the final product. In these circumstances, the OEM integrator will be responsible for re-evaluating the end product (including the transmitter) and obtaining a separate FCC authorization.

7.3.2. End Product Labeling

This transmitter module is authorized only for use in device where the antenna may be installed such that 20 cm may be maintained between the antenna and users. The final end product must be labeled in a visible area with the following: "Contains FCC ID: **N7NHL78M**". The grantee's FCC ID can be used only when all FCC compliance requirements are met.

7.3.3. Manual Information to the End User

The OEM integrator has to be aware not to provide information to the end user regarding how to install or remove this RF module in the user's manual of the end product which integrates this module.

The end user manual shall include all required regulatory information/warning as shown in this manual.

7.3.4. Antenna Installation

The RF signal must be routed on the application board using tracks with a 50 Ω characteristic impedance. Basically, the characteristic impedance depends on the dielectric, the track width and the ground plane spacing. In order to respect this constraint, Sierra Wireless recommends using MicroStrip or StripLine structure and computing the track's width with a simulation tool (like AppCad shown in the figure below and that is available free of charge at <https://www.broadcom.com/appcad>).

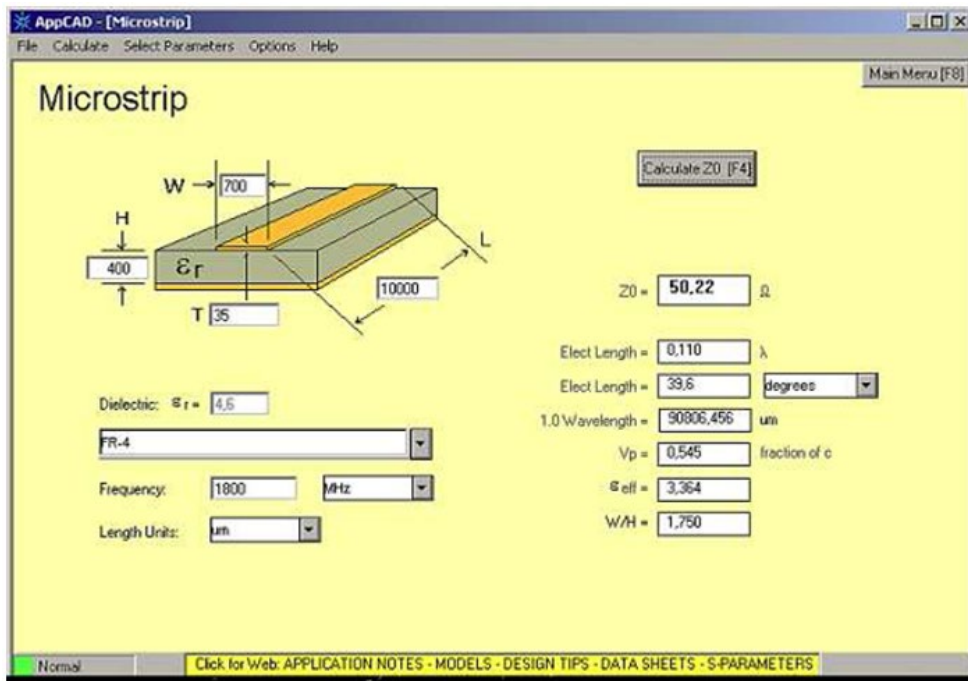

If a multi-layered PCB is used, the RF path on the board must not cross any signal (digital, analog or supply).

If necessary, use Stripline structure and route the digital line(s) "outside" the RF structure. An example of proper routing is shown in the figure below.



Stripline and Coplanar design requires having a correct ground plane at both sides. Consequently, it is necessary to add some vias along the RF path. RF tracks must be isolated from any others signals by ground.

RF tracks width should be as large as possible to reduce the insertion loss (at least > 250 μm). In many cases, depending on PCB layout structure, it is easier to have a large RF tracks width with Microstrip structure compared to Stripline or Coplanar structure.

The RF signal (when transmitting) may interfere with neighboring electronics (AF amplifier, etc.) In the same way, the neighboring electronics (microcontrollers, etc.) may degrade the reception performances. In such cases, Stripline structure can be useful because the RF track is shielded.

The GSM/GPRS connector is intended to be directly connected to a 50Ω antenna and no matching is needed.

7.4. IC Statement

This device complies with Industry Canada license-exempt RSS standard(s). Operation is subject to the following two conditions:

1. this device may not cause interference, and
2. this device must accept any interference, including interference that may cause undesired operation of the device.

Le présent appareil est conforme aux CNR d'Industrie Canada applicables aux appareils radio exempts de licence. L'exploitation est autorisée aux deux conditions suivantes:

1. l'appareil ne doit pas produire de brouillage, et
2. l'utilisateur de l'appareil doit accepter tout brouillage radioélectrique subi, même si le brouillage est susceptible d'en compromettre le fonctionnement.

This Class B digital apparatus complies with Canadian ICES-003.

Cet appareil numérique de la classe B est conforme à la norme NMB-003 du Canada.

This device complies with RSS-310 of Industry Canada. Operation is subject to the condition that this device does not cause harmful interference.

Cet appareil est conforme à la norme RSS-310 d'Industrie Canada. L'opération est soumise à la condition que cet appareil ne provoque aucune interférence nuisible.

This device and its antenna(s) must not be co-located or operating in conjunction with any other antenna or transmitter, except tested built-in radios.

Cet appareil et son antenne ne doivent pas être situés ou fonctionner en conjonction avec une autre antenne ou un autre émetteur, exception faites des radios intégrées qui ont été testées.

The County Code Selection feature is disabled for products marketed in the US/ Canada.

La fonction de sélection de l'indicatif du pays est désactivée pour les produits commercialisés aux États-Unis et au Canada.

7.4.1. Radiation Exposure Statement / Déclaration d'Exposition aux Radiations

This equipment complies with IC radiation exposure limits set forth for an uncontrolled environment. This equipment should be installed and operated with minimum distance 20 cm between the radiator and your body.

Cet équipement est conforme aux limites d'exposition aux rayonnements IC établies pour un environnement non contrôlé. Cet équipement doit être installé et utilisé avec un minimum de 20 cm de distance entre la source de rayonnement et votre corps.

This device is intended only for OEM integrators under the following conditions: (For module device use)

1. The antenna must be installed such that 20 cm is maintained between the antenna and users, and
2. The transmitter module may not be co-located with any other transmitter or antenna.

As long as the 2 conditions above are met, further transmitter test will not be required. However, the OEM integrator is still responsible for testing their end-product for any additional compliance requirements required with this module installed.

Cet appareil est conçu nt pour les intégrateurs OEM dans les conditions suivantes: (Pour utilisation de dispositif module)

1. L'antenne doit être installée de telle sorte qu'une distance de 20 cm est respectée entre l'antenne et les utilisateurs, et
2. Le module émetteur peut ne pas être coïmplanté avec un autre émetteur ou antenne.

Tant que les 2 conditions ci-dessus sont remplies, des essais supplémentaires sur l'émetteur ne seront pas nécessaires. Toutefois, l'intégrateur OEM est toujours responsable des essais sur son produit final pour toutes exigences de conformité supplémentaires requis pour ce module installé.

IMPORTANT NOTE: In the event that these conditions cannot be met (for example certain laptop configurations or co-location with another transmitter), then the Canada authorization is no longer considered valid and the IC ID cannot be used on the final product. In these circumstances, the OEM integrator will be responsible for re-evaluating the end product (including the transmitter) and obtaining a separate Canada authorization.

NOTE IMPORTANTE: Dans le cas où ces conditions ne peuvent être satisfaites (par exemple pour certaines configurations d'ordinateur portable ou de certaines co-localisation avec un autre émetteur), l'autorisation du Canada n'est plus considéré comme valide et l'ID IC ne peut pas être utilisé sur le produit final. Dans ces circonstances, l'intégrateur OEM sera chargé de réévaluer le produit final (y compris l'émetteur) et l'obtention d'une autorisation distincte au Canada.

7.4.2. End Product Labeling / Plaque Signalétique du Produit Final

This transmitter module is authorized only for use in device where the antenna may be installed such that 20 cm may be maintained between the antenna and users. The final end product must be labeled in a visible area with the following: "Contains IC: **2417C-HL78M**".

Ce module émetteur est autorisé uniquement pour une utilisation dans un dispositif où l'antenne peut être installée de telle sorte qu'une distance de 20cm peut être maintenue entre l'antenne et les utilisateurs. Le produit final doit être étiqueté dans un endroit visible avec l'inscription suivante: "Contient des IC: **2417C-HL78M**".

7.4.3. Manual Information to the End User / Manuel d'Information à l'Utilisateur Final

The OEM integrator has to be aware not to provide information to the end user regarding how to install or remove this RF module in the user's manual of the end product which integrates this module.

The end user manual shall include all required regulatory information/warning as show in this manual.

L'intégrateur OEM doit être conscient de ne pas fournir des informations à l'utilisateur final quant à la façon d'installer ou de supprimer ce module RF dans le manuel de l'utilisateur du produit final qui intègre ce module.

Le manuel de l'utilisateur final doit inclure toutes les informations réglementaires requises et avertissements comme indiqué dans ce manuel.



8. Ordering Information

Table 54. Ordering Information

Model Name	Description	Part Number
HL7800	HL7800 embedded module	Contact Sierra Wireless for the latest SKU
HL7800-M	HL7800-M embedded module	Contact Sierra Wireless for the latest SKU
DEV-KIT	HL Series Development Kit	6001210

9. Terms and Abbreviations

Abbreviation	Definition
ADC	Analog to Digital Converter
AGC	Automatic Gain Control
AT	Attention (prefix for modem commands)
CDMA	Code Division Multiple Access
CF3	Common Flexible Form Factor
CLK	Clock
CODEC	Coder Decoder
CPU	Central Processing Unit
DAC	Digital to Analog Converter
DTR	Data Terminal Ready
DRX	Discontinuous Reception
eDRX	Extended DRX
EMC	Electro-Magnetic Compatibility
EMI	Electro-Magnetic Interference
EN	Enable
ESD	Electro-Static Discharges
ETSI	European Telecommunications Standards Institute
FDMA	Frequency-division multiple access
GLONASS	Global Navigation Satellite System
GND	Ground
GNSS	Global Navigation Satellite System
GPIO	General Purpose Input Output
GPRS	General Packet Radio Service
GPS	Global Positioning System
GSM	Global System for Mobile communications
Hi Z	High impedance (Z)
IC	Integrated Circuit
IMEI	International Mobile Equipment Identification
I/O	Input / Output
LED	Light Emitting Diode
LNA	Low Noise Amplifier
MAX	Maximum
MIN	Minimum
N/A	Not Applicable
PA	Power Amplifier
PC	Personal Computer
PCB	Printed Circuit Board
PCL	Power Control Level
PLL	Phase Lock Loop
PSM	Power Save Mode
PSRAM	Pseudo Static RAM

Abbreviation	Definition
PSU	Power Supply Unit
PTW	Paging Transmission Window
PWM	Pulse Width Modulation
RF	Radio Frequency
RFI	Radio Frequency Interference
RMS	Root Mean Square
RST	Reset
RTC	Real Time Clock
RX	Receive
SCL	Serial Clock
SDA	Serial Data
SIM	Subscriber Identification Module
SMD	Surface Mounted Device/Design
SPI	Serial Peripheral Interface
SW	Software
TAU	Tracking Area Update
TBC	To Be Confirmed
TBD	To Be Defined
TP	Test Point
TX	Transmit
TYP	Typical
UART	Universal Asynchronous Receiver-Transmitter
UICC	Universal Integrated Circuit Card
USB	Universal Serial Bus
UIM	User Identity Module
VBATT	Main Supply Voltage from Battery or DC adapter
VSWR	Voltage Standing Wave Ratio