

PART NUMBER	REV	FIRST USED
687797-1	F	122500-1
687797-2	H	565435-5

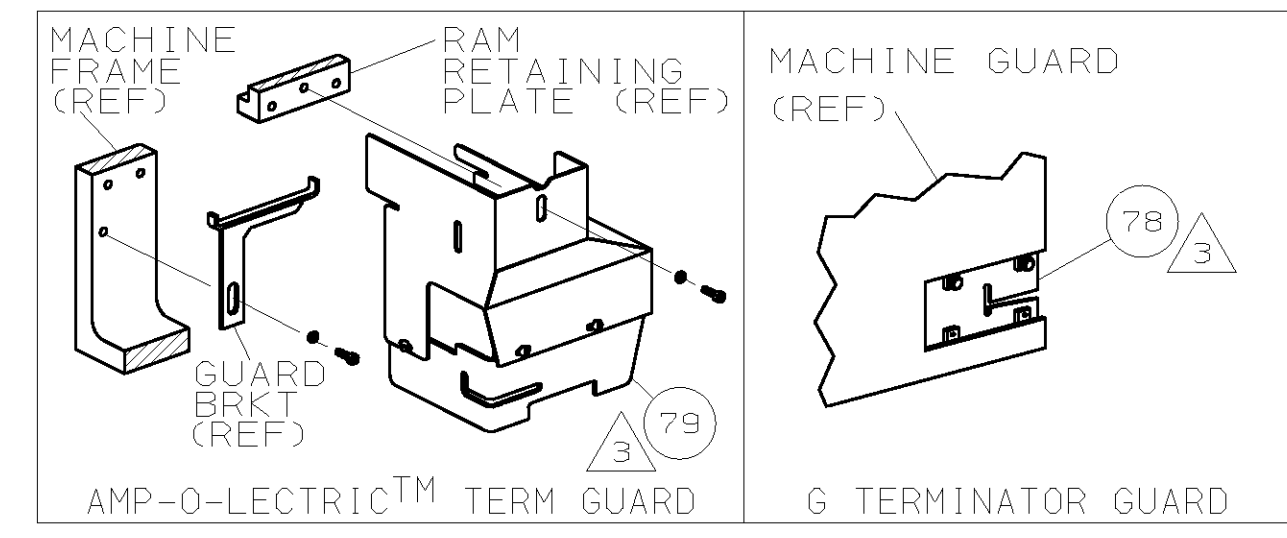

TERMINAL NAME: WELD TAB						
		CRIMPING DATA				
PAD LTR	CRIMP HEIGHT	WIRE SIZE				
A	.065 ±.002 [1.65 ±0.05mm]	16				
B	.059 ±.002 [1.50 ±0.05mm]	18				
C	.055 ±.002 [1.40 ±0.05mm]	20				
D	NOT	USED				
CRIMP	SIZE	TYPE	RANGE			
WIRE	.110 [2.79mm]	F	20-16			
INSUL	-	-	-			
WIRE STRIP LENGTH	TERM APPL	SPEC	FEED	APPL INSTRUCTION	SET UP GAGE	LAYOUT
.109-.141	NONE		.385	408-8039	458638-1	650

-1		LEADMAKER & BENCH MODEL G		MECH POST FEED		
-2		BENCH MODEL K		MECH POST FEED		
REF	REF	-	A	22594-8	NUT, HEX	70
REF	REF	-	B	240628-1	PLATE, ADJ	69
REF	REF	-	B	240626-1	SHAFT, PIVOT	68
REF	REF	-	B	240633-1	BUSHING	67
REF	REF	-	A	455680-1	LEVER, INTERMEDIATE	66
REF	REF	-	B	240629-1	BLOCK, PIVOT	65
REF	REF	-	A	240632-2	SCR, ADJ	64
REF	REF	-	B	240659-3	PIN, CAM ROLLER	63
REF	REF	-	B	240658-1	CAM, ROLLER	62
REF	REF	-	B	454398-1	ROD, FEED	61
REF	REF	-	C	454220-1	CAP, RAM	59
REF	REF	-	D	453736-1	HOUSING	58
REF	REF	-	B	240624-1	PIN, FEED FINGER	55
REF	REF	-	B	691499-1	SPRING, FEED FINGER	54
REF	REF	-	B	240635-1	FINGER, FEED	53
REF	REF	-	B	240634-1	LEVER, TERMINAL	52
REF	REF	-	C	454220-1	CAP, RAM	59
REF	REF	-	D	453736-1	HOUSING	58
REF	REF	-	B	690501-3	CAM, POST FEED 1 1/8 ST	48
REF	REF	-	B	690501-4	CAM, POST-FEED 1 5/8 ST	47
REF	REF	-	A	690191-1	PLUG, NYLON	45
REF	REF	-	C	455674-2	RAM	44
REF	REF	-	A	690125-1	WASHER, LAMINATED	43
REF	REF	-	A	690124-1	WASHER, RAM	42
REF	REF	-	A	7-21002-9	BOLT, CRIMPER (5/16-24x1.00)	41
REF	REF	-	A	690223-2	SPACER, INSULATION DISC	38
REF	REF	-	D	354777-1	WIRE DISC, PLASTIC	37
REF	REF	-	A	22480-5	WASHER, SPRING	36
REF	REF	-	B	690212-1	POST, RAM	35
REF	REF	-	A	458980-1	APPLICATOR, BASIC (SUB ASSY)	32
REF	REF	-	B	3-690451-2	SPACER, STRIPPER	28
REF	REF	-	A	240639-1	STRIPPER	27
REF	REF	-	C	455676-1	PLATE, BASE	26
REF	REF	-	A	22354-8	DRAG, STUD	25
REF	REF	-	B	455678-1	PLATE, STRIP GUIDE	24
REF	REF	-	A	4-22281-1	SPRING, DRAG	22
REF	REF	-	A	454177-1	DRAG, STOCK	20
REF	REF	-	B	1-458030-7	GUIDE, STRIP (REAR)	19
REF	REF	-	C	1-458031-7	GUIDE, STRIP (FRONT)	18
REF	REF	-	A	454178-1	GUIDE, FEED ROD	17
REF	REF	-	A	4-22284-9	SPRING, FEED RETURN	16
REF	REF	-	A	456408-1	CRIMPER, WIRE	1

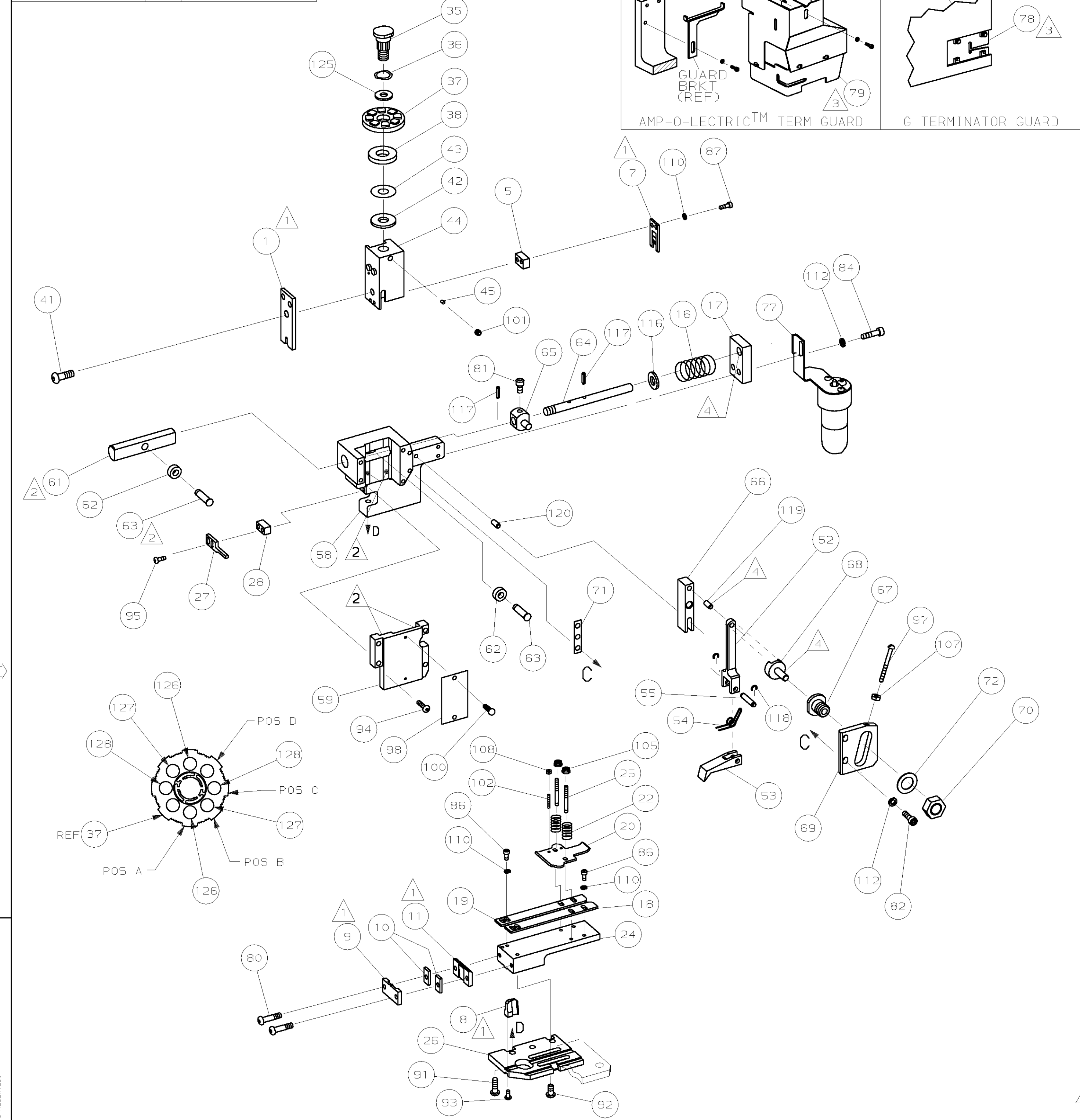

QTY	REF	REV	U/M	DWG SIZE	PART NO	DESCRIPTION	ITEM NO
2	2	-	C		1-354779-2	PIN, WIRE DISC (.3050)C	129
2	2	-	C		354779-4	PIN, WIRE DISC (.3010)B	127
2	2	-	C		9-354778-1	PIN, WIRE DISC (.2950)A	126
1	1	-	A		986950-1	WASHER, FLAT PRECISION	125
1	1	-	A		217238-1	GENERAL INSTRUCTION PACKAGE	124
1	1	-	-		4088039	EF APPL INST 408-8039	123
REF	REF	-	A		1-21030-7	PIN, DOWEL (Ø.187x1.50)H5G	120
REF	REF	-	A		1-21030-1	PIN, DOWEL (Ø.187x.50)LEVER	119
REF	REF	-	A		21045-3	RING, RET "C" (Ø.187)FD PIN	118
REF	REF	-	A		5-21028-1	PIN, STD SPRING (Ø.12)FD ADJ ROD	117
REF	REF	-	A		21899-4	WASHER, FLAT (Ø5/16) SCR ADJ	116
REF	REF	-	A		21024-5	WASHER, LOCK (NO.10)FD ROD GDE	112
6	6	-	A		21024-4	WASHER, LOCK (NO.8)SHEAR BL	110
2	2	-	A		21018-4	NUT, HEX (4-40)DRAG	108
REF	REF	-	A		21018-5	NUT, HEX (6-32)FD ADJ PL	107
2	2	-	A		21022-2	NUT, HEX SL (8-32)DRAG STUD	105
2	2	-	A		2-21006-6	SCR, SKT SET (4-40x.62)DRAG	102
1	1	-	A		21009-2	SCR, SKT SET (1/4-20x.25)RAM	101
2	2	-	A		21017-2	SCR, DRIVE (#2x.19)ID PLATE	100
1	1	-	A		1-21002-7	SCR, BHC (6-32x.38)CAM	99
1	1	-	B		461264-1	PLATE, IDENTIFICATION	98
REF	REF	-	A		6-23715-5	SCR, PAN HD (6-32x1.50)FEED ADJ	97
2	2	-	A		2-21002-2	SCR, BHC (8-32x.50)STRIPPER	95
REF	REF	-	A		2-21002-9	SCR, BHC (10-32x.75)H5G CAP	94
1	1	-	A		22733-8	SCR, BHC (8-32x.38 LW)ANVIL	93
4	4	-	A		3-21002-3	SCR, BHC (1/4-20x.50)ST 6D PL	92
REF	REF	-	A		2-22733-8	SCR, BHC (1/4-20x.62)BASE PL	91
REF	REF	-	A		3-21000-7	SCR, 5HC (10-32x.75)FEED ROD GDE	84
REF	REF	-	A		3-21000-6	SCR, 5HC (10-32x.62)FEED ADJ PL	82
REF	REF	-	A		3-21000-4	SCR, 5HC (10-32x.38)PIVOT BLOCK	81
2	2	-	A		3-21002-0	SCR, BHC (10-32x.88)SHEAR PL	80
REF	-	-	A		455745-1	GUARD, WINDOW	79
-	REF	-	A		679532-1	INSERT, GUARD	78
1	-	-	C		465184-9	LUBRICATOR ASSY	77
REF	REF	-	A		458109-1	WASHER, FLAT (SPECIAL)	72
REF	REF	-	A		690517-1	SPACER	71

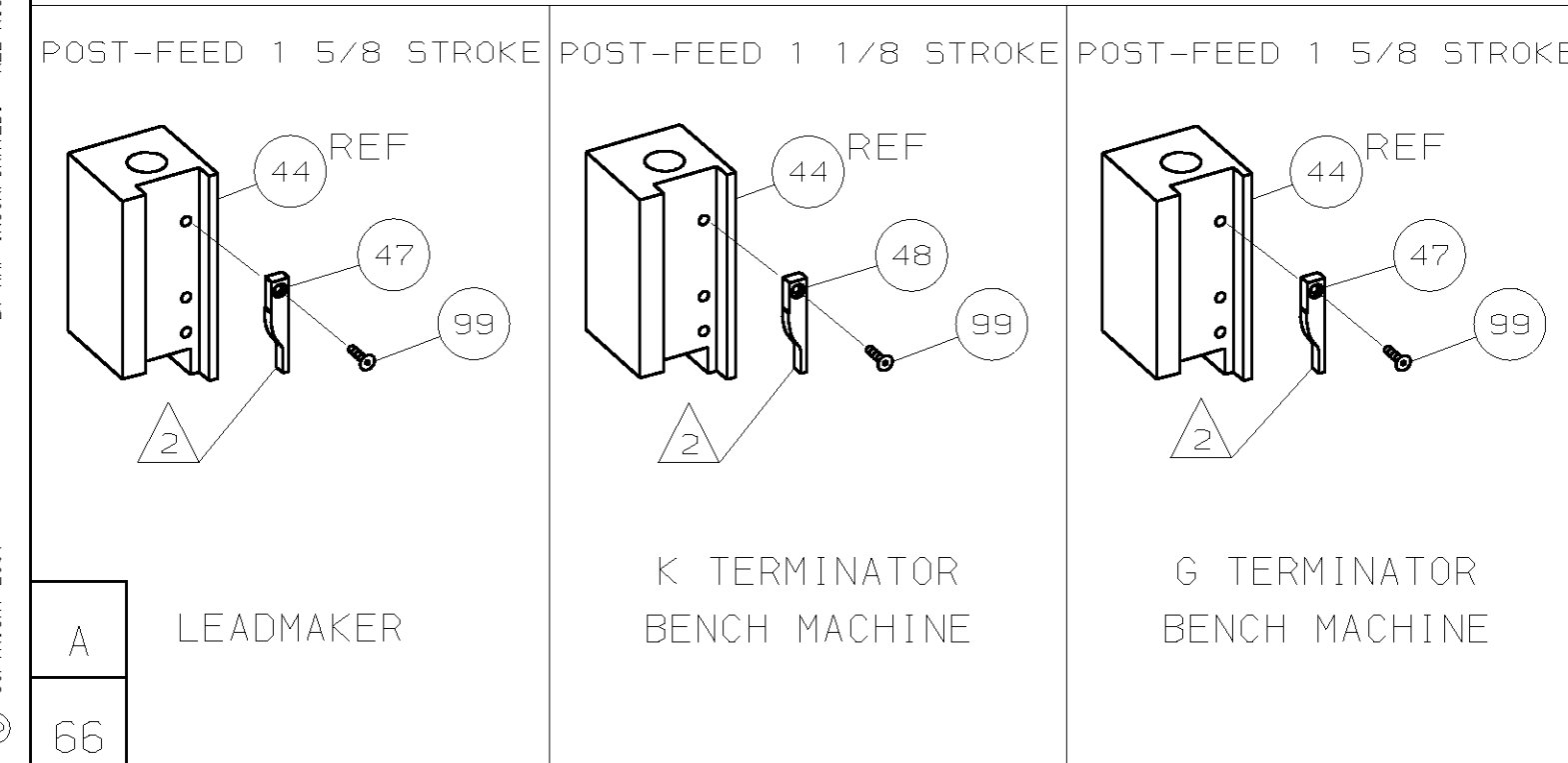

- 1 RECOMMENDED SPARE PARTS.
- 2 GREASE LIGHTLY.
- 3 GUARD MUST BE IN PLACE WHEN OPERATING APPLICATOR IN A BENCH MACHINE.
- 4 LUBRICATE DAILY USING NO. 20 MACHINE OIL.
- 5. ITEMS WITH QTY OF REF SPECIFIED (EXCEPT ITEMS 78 AND 79) ARE USED ON ITEM 32.
- 6 ITEM 78 USED WITH G TERMINATOR ONLY.

QTY	REF	REV	U/M	DWG SIZE	PART NO	DESCRIPTION	ITEM NO
-2	-1	-	U/M				

-1		LEADMAKER & BENCH MODEL G		MECH POST FEED		
-2		BENCH MODEL K		MECH POST FEED		
REF	REF	-	A	22594-8	NUT, HEX	70
REF	REF	-	B	240628-1	PLATE, ADJ	69
REF	REF	-	B	240626-1	SHAFT, PIVOT	68
REF	REF	-	B	240633-1	BUSHING	67
REF	REF	-	A	455680-1	LEVER, INTERMEDIATE	66
REF	REF	-	B	240629-1	BLOCK, PIVOT	65
REF	REF	-	A	240632-2	SCR, ADJ	64
REF	REF	-	B	240659-3	PIN, CAM ROLLER	63
REF	REF	-	B	240658-1	CAM, ROLLER	62
REF	REF	-	B	454398-1	ROD, FEED	61
REF	REF	-	C	454220-1	CAP, RAM	59
REF	REF	-	D	453736-1	HOUSING	58
REF	REF	-	B	240624-1	PIN, FEED FINGER	55
REF	REF	-	B	691499-1	SPRING, FEED FINGER	54
REF	REF	-	B	240635-1	FINGER, FEED	53
REF	REF	-	B	240634-1	LEVER, TERMINAL	52
REF	REF	-	C	454220-1	CAP, RAM	59
REF	REF	-	D	453736-1	HOUSING	58
REF	REF	-	B	690501-3	CAM, POST FEED 1 1/8 ST	48
REF	REF	-	B	690501-4	CAM, POST-FEED 1 5/8 ST	47
REF	REF	-	A	690191-1	PLUG, NYLON	45
REF	REF	-	C	455674-2	RAM	44
REF	REF	-	A	690125-1	WASHER, LAMINATED	43
REF	REF	-	A	690124-1	WASHER, RAM	42
REF	REF	-	A	7-21002-9	BOLT, CRIMPER (5/16-24x1.00)	41
REF	REF	-	A	690223-2	SPACER, INSULATION DISC	38
REF	REF	-	D	354777-1	WIRE DISC, PLASTIC	37
REF	REF	-	A	22480-5	WASHER, SPRING	36
REF	REF	-	B	690212-1	POST, RAM	35
REF	REF	-	A	458980-1	APPLICATOR, BASIC (SUB ASSY)	32
REF	REF	-	B	3-690451-2	SPACER, STRIPPER	28
REF	REF	-	A	240639-1	STRIPPER	27
REF	REF	-	C	455676-1	PLATE, BASE	26
REF	REF	-	A	22354-8	DRAG, STUD	25
REF	REF	-	B	455678-1	PLATE, STRIP GUIDE	24
REF	REF	-	A	4-22281-1	SPRING, DRAG	22
REF	REF	-	A	454177-1	DRAG, STOCK	20
REF	REF	-	B	1-458030-7	GUIDE, STRIP (REAR)	19
REF	REF	-	C	1-458031-7	GUIDE, STRIP (FRONT)	18
REF	REF	-	A	454178-1	GUIDE, FEED ROD	17
REF	REF	-	A	4-22284-9	SPRING, FEED RETURN	16
REF	REF	-	A	456408-1	CRIMPER, WIRE	1