

# ISO7041 Ultra-Low Power Four-Channel Digital Isolator

## 1 Features

- Ultra-low power consumption
  - 3.5  $\mu\text{A}$  per channel quiescent current (3.3 V)
  - 15  $\mu\text{A}$  per channel at 100 kbps (3.3 V)
  - 116  $\mu\text{A}$  per channel at 1 Mbps (3.3 V)
- Robust isolation barrier
  - >100-year projected lifetime
  - 3000  $V_{\text{RMS}}$  isolation rating
  - $\pm 100$  kV/ $\mu\text{s}$  typical CMTI
- Wide supply range: 1.71 V to 1.89 V and 2.25 V to 5.5 V
- Wide temperature range:
  - 1.71 V to 1.89 V:  $-55^{\circ}\text{C}$  to  $+105^{\circ}\text{C}$
  - 2.25 V to 5.5 V:  $-55^{\circ}\text{C}$  to  $+125^{\circ}\text{C}$
- Small 16-QSOP package (16-DBQ)
- Signaling rate: Up to 4 Mbps
- Default output *High* (ISO7041) and *Low* (ISO7041F) options
- Robust electromagnetic compatibility (EMC)
  - System-level ESD, EFT, and surge immunity
  - $\pm 8$  kV IEC 61000-4-2 contact discharge protection across isolation barrier
  - Very low emissions
- Safety-related certifications :
  - UL 1577 Component Recognition Program
  - DIN VDE V 0884-11
  - CQC, TUV and CSA
  - IECEX (IEC 60079-0 & IEC 60079-11) and ATEX (EN 60079-0 & EN 60079-11)

## 2 Applications

- 4-mA to 20-mA loop powered field transmitters
- Factory automation and process automation
- Low-power GPIO, UART and SPI isolation

## 3 Description

The ISO7041 device is an ultra-low power, multichannel digital isolator that can be used to isolate CMOS or LVCMOS digital I/Os. Each isolation channel has a logic input and output buffer separated by a double capacitive silicon dioxide ( $\text{SiO}_2$ ) insulation barrier. Innovative edge based architecture combined with an ON-OFF keying modulation scheme allows these isolators to consume very-low power while meeting 3000- $V_{\text{RMS}}$  isolation rating per UL1577. The per channel dynamic current consumption of the device is under 120  $\mu\text{A}/\text{Mbps}$  and the per channel static current consumption is 3.5  $\mu\text{A}$  at 3.3 V, allowing for use of the ISO7041 in both power and thermal constrained system designs.

The device can operate as low as 1.71 V, as high as 5.5 V, and is fully functional with different supply voltages on each side of isolation barrier. The four channel isolator comes in a 16-QSOP package with three forward-direction channels and one reverse-direction channel. The device has default output high and low options. If the input power or signal is lost, default output is *high* for the ISO7041 device without the suffix F and *low* for the ISO7041F device with the F suffix. See the [Device Functional Modes](#) section for more information.

### Device Information<sup>(1)</sup>

PART NUMBER	PACKAGE	BODY SIZE (NOM)
ISO7041	QSOP (16)	4.90 mm × 3.90 mm

(1) For all available packages, see the orderable addendum at the end of the data sheet.

### Simplified Application Schematic

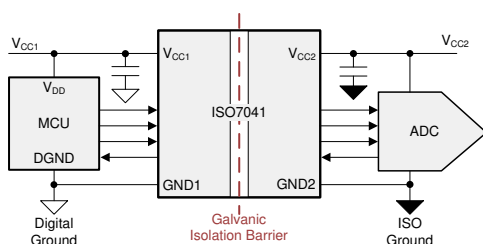

### Data Rate vs Power Consumption at 3.3 V

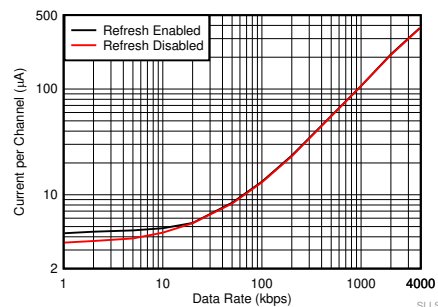

## Table of Contents

<b>1 Features</b> .....	1	7.18 Insulation Characteristics Curves .....	18
<b>2 Applications</b> .....	1	7.19 Typical Characteristics .....	18
<b>3 Description</b> .....	1	<b>8 Parameter Measurement Information</b> .....	20
<b>4 Revision History</b> .....	2	<b>9 Detailed Description</b> .....	21
<b>5 Device Comparison Table</b> .....	4	9.1 Overview .....	21
<b>6 Pin Configuration and Functions</b> .....	5	9.2 Functional Block Diagram .....	21
<b>7 Specifications</b> .....	6	9.3 Feature Description .....	21
7.1 Absolute Maximum Ratings .....	6	9.4 Device Functional Modes .....	23
7.2 ESD Ratings .....	6	<b>10 Application and Implementation</b> .....	25
7.3 Recommended Operating Conditions .....	6	10.1 Application Information .....	25
7.4 Thermal Information .....	8	10.2 Typical Application .....	27
7.5 Power Ratings .....	8	<b>11 Power Supply Recommendations</b> .....	29
7.6 Insulation Specifications .....	9	<b>12 Layout</b> .....	30
7.7 Safety-Related Certifications .....	10	12.1 Layout Guidelines .....	30
7.8 Safety Limiting Values .....	10	12.2 Layout Example .....	30
7.9 Electrical Characteristics 5V Supply .....	11	<b>13 Device and Documentation Support</b> .....	31
7.10 Supply Current Characteristics 5V Supply .....	11	13.1 Documentation Support .....	31
7.11 Electrical Characteristics 3.3V Supply .....	13	13.2 Receiving Notification of Documentation Updates .....	31
7.12 Supply Current Characteristics 3.3V Supply .....	13	13.3 Community Resource .....	31
7.13 Electrical Characteristics 2.5V Supply .....	15	13.4 Trademarks .....	31
7.14 Supply Current Characteristics 2.5V Supply .....	15	13.5 Electrostatic Discharge Caution .....	31
7.15 Electrical Characteristics 1.8V Supply .....	16	13.6 Glossary .....	31
7.16 Supply Current Characteristics 1.8V Supply .....	16	<b>14 Mechanical, Packaging, and Orderable Information</b> .....	31
7.17 Switching Characteristics .....	17		

## 4 Revision History

NOTE: Page numbers for previous revisions may differ from page numbers in the current version.

Changes from Revision C (January 2020) to Revision D	Page
• Increased supply range to support 1.71 V to 1.89 V .....	1
• Increased 3.6 V to 5.5 V support temperature range to 125°C and added -55°C to 105°C temperature range for 1.71 V to 1.89 V support .....	1
• Increased max signaling rate to 4 Mbps .....	1
• Increased maximum data rate to 4 Mbps .....	4
• Added 1.8 V support to <a href="#">Recommended Operating Conditions</a> .....	6
• Changed data rate maximum to 4 Mbps in <a href="#">Recommended Operating Conditions</a> .....	7
• Added temperature range for 1.71 V to 1.89 V supply range .....	7
• Added up to 5.5 V support across entire temperature range .....	7
• Added 1.8 V support in <a href="#">Safety Limiting Values</a> .....	10
• Added 1.8 V Electrical Characteristics .....	16
• Added 1.8 V supply current characteristics .....	16
• Added 1.8 V support to <a href="#">Switching Characteristics</a> .....	17
• Changed minimum pulse width to 250 ns in <a href="#">Switching Characteristics</a> .....	17
• Updated all datasheet plots and curves to support 1.8 V .....	18
• Added 1.8 V support to Functional Table .....	23
• Added 1.8 V support to the <a href="#">Application Information</a> .....	25
• Extended power supply range to support 1.71 V to 1.89 V in <a href="#">Design Requirements</a> .....	28
• Updated speed to 4 Mbps .....	29
• Added eye diagrams for full voltage range support and 4 Mbps .....	29

<b>Changes from Revision B (July 2019) to Revision C</b>	<b>Page</b>
• Removed (planned) for Safety-related certifications in <a href="#">Features</a> .....	1
• Added Certificate numbers for all agencies.....	10
• Added <a href="#">Intrinsic Safety</a> section .....	27

<b>Changes from Revision A (December 2018) to Revision B</b>	<b>Page</b>
• Updated front page channel quiescent current to match data in tables .....	1
• Increased supply range to support up to 5.5 V in <a href="#">Features</a> .....	1
• Split temperature range to support -40°C for 3.6 V to 5.5 V in <a href="#">Features</a> .....	1
• Added ±8 kV IEC 61000-4-2 contact discharge protection across isolation barrier in <a href="#">Features</a> .....	1
• Increased supply range to 5.5 V in <a href="#">Description</a> .....	1
• Added ±8 kV IEC 61000-4-2 contact discharge protection across isolation barrier .....	6
• Added 5 V support to <a href="#">Recommended Operating Conditions</a> .....	6
• Added power dissipation maximum numbers to support 5.5 V in <a href="#">Power Ratings</a> .....	8
• Added 5.5 V support in <a href="#">Safety Limiting Values</a> .....	10
• Added 5 V Electrical Characteristics section.....	11
• Added 5 V Supply Current Characteristics section .....	11
• Updated Device I/O schematics removing (F version) only text in <a href="#">Figure 15</a> .....	24

## 5 Device Comparison Table

**Table 1. Device Features**

PART NUMBER	CHANNEL DIRECTION	MAXIMUM DATA RATE	DEFAULT OUTPUT	PACKAGE	RATED ISOLATION
ISO7041	3 Forward, 1 Reverse	4 Mbps	High	DBQ-16	3000 V <sub>RMS</sub> / 4242 V <sub>PK</sub>
ISO7041 with F suffix	3 Forward, 1 Reverse	4 Mbps	Low	DBQ-16	3000 V <sub>RMS</sub> / 4242 V <sub>PK</sub>

## 6 Pin Configuration and Functions

ISO7041 DBQ Package  
16-Pin QSOP  
Top View

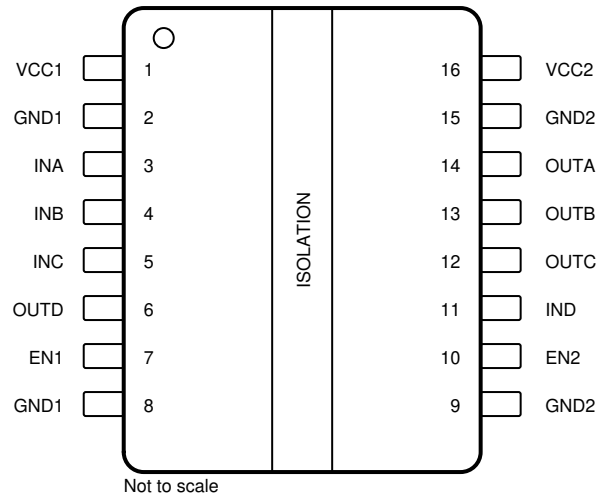

### Pin Functions

PIN		I/O	DESCRIPTION
NAME	NO.		
EN1	7	I	Refresh enable 1. Refresh is enabled when the EN1 pin is connected to GND1. Disable refresh by connecting the EN1 pin high to $V_{CC1}$ . EN1 and EN2 must be connected to the same logic state to enable or disable refresh.
EN2	10	I	Refresh enable 2. Refresh is enabled when the EN2 pin is connected to GND2. Disable refresh by connecting the EN2 pin high to $V_{CC2}$ . EN1 and EN2 must be connected to the same logic state to enable or disable refresh.
GND1	2	—	Ground connection for $V_{CC1}$
	8		
GND2	9	—	Ground connection for $V_{CC2}$
	15		
INA	3	I	Input, channel A
INB	4	I	Input, channel B
INC	5	I	Input, channel C
IND	11	I	Input, channel D
OUTA	14	O	Output, channel A
OUTB	13	O	Output, channel B
OUTC	12	O	Output, channel C
OUTD	6	O	Output, channel D
$V_{CC1}$	1	—	Power supply, side 1
$V_{CC2}$	16	—	Power supply, side 2

## 7 Specifications

### 7.1 Absolute Maximum Ratings

 over operating free-air temperature range (unless otherwise noted)<sup>(1)(2)(3)</sup>

		MIN	MAX	UNIT
Supply Voltage	V <sub>CC1</sub> to GND1	-0.5	6	V
	V <sub>CC2</sub> to GND2	-0.5	6	
Input/Output Voltage	IN <sub>x</sub> to GND <sub>x</sub>	-0.5	V <sub>CCX</sub> + 0.5	V
	OUT <sub>x</sub> to GND <sub>x</sub>	-0.5	V <sub>CCX</sub> + 0.5	
	EN <sub>x</sub> to GND <sub>x</sub>	-0.5	V <sub>CCX</sub> + 0.5	
Output Current	I <sub>o</sub>	-15	15	mA
Temperature	Operating junction temperature, T <sub>J</sub>		150	°C
	Storage temperature, T <sub>stg</sub>	-65	150	°C

- Stresses beyond those listed under Absolute Maximum Ratings may cause permanent damage to the device. These are stress ratings only, which do not imply functional operation of the device at these or any other conditions beyond those indicated under Recommended Operating Conditions. Exposure to absolute-maximum-rated conditions for extended periods may affect device reliability.
- All voltage values except differential I/O bus voltages are with respect to the local ground terminal (GND1 or GND2) and are peak voltage values
- Maximum voltage must not exceed 6 V.

### 7.2 ESD Ratings

			VALUE	UNIT
V <sub>(ESD)</sub>	Electrostatic discharge	Human body model (HBM), per ANSI/ESDA/JEDEC JS-001, all pins <sup>(1)</sup>	±6000	V
		Charged device model (CDM), per JEDEC specification JESD22-C101, all pins <sup>(2)</sup>	±1500	
		Contact discharge per IEC 61000-4-2; Isolation barrier withstand test <sup>(3)(4)</sup>	±8000	

- JEDEC document JEP155 states that 500-V HBM allows safe manufacturing with a standard ESD control process.
- JEDEC document JEP157 states that 250-V CDM allows safe manufacturing with a standard ESD control process.
- IEC ESD strike is applied across the barrier with all pins on each side tied together creating a two-terminal device.
- Testing is carried out in air or oil to determine the intrinsic contact discharge capability of the device.

### 7.3 Recommended Operating Conditions

over operating free-air temperature range (unless otherwise noted)

		MIN	NOM	MAX	UNIT
V <sub>CC1</sub> <sup>(1)</sup>	Supply Voltage Side 1	1.71		1.89	V
V <sub>CC1</sub> <sup>(1)</sup>	Supply Voltage Side 1	2.25		5.5	V
V <sub>CC2</sub> <sup>(1)</sup>	Supply Voltage Side 2	1.71		1.89	V
V <sub>CC2</sub> <sup>(1)</sup>	Supply Voltage Side 2	2.25		5.5	V
V <sub>IH</sub>	High level Input voltage	0.7 x V <sub>CC1</sub> <sup>(2)</sup>		V <sub>CC1</sub>	V
V <sub>IL</sub>	Low level Input voltage	0		0.3 x V <sub>CC1</sub>	V
I <sub>OH</sub>	High level output current	V <sub>CCO</sub> <sup>(2)</sup> = 5 V		-4	mA
		V <sub>CCO</sub> = 3.3 V		-2	mA
		V <sub>CCO</sub> = 2.5 V		-1	mA
		V <sub>CCO</sub> = 1.8 V		-1	mA
I <sub>OL</sub>	Low level output current	V <sub>CCO</sub> = 5 V		4	mA
		V <sub>CCO</sub> = 3.3 V		2	mA
		V <sub>CCO</sub> = 2.5 V		1	mA
		V <sub>CCO</sub> = 1.8 V		1	mA

- V<sub>CC1</sub> and V<sub>CC2</sub> can be set independent of one another
- V<sub>CC1</sub> = Input-side V<sub>CC</sub>; V<sub>CCO</sub> = Output-side V<sub>CC</sub>

**Recommended Operating Conditions (continued)**

over operating free-air temperature range (unless otherwise noted)

			<b>MIN</b>	<b>NOM</b>	<b>MAX</b>	<b>UNIT</b>
DR	Data Rate		0		4	Mbps
T <sub>A</sub>	Ambient temperature	V <sub>CC1</sub> , V <sub>CC2</sub> = 1.71 V to 1.89 V	-55		105	°C
		V <sub>CC1</sub> , V <sub>CC2</sub> = 2.25 V to 5.5 V	-55		125	°C

## 7.4 Thermal Information

THERMAL METRIC <sup>(1)</sup>		ISO7041	
		DBQ (SOIC)	
		16 PINS	
			UNIT
$R_{\theta JA}$	Junction-to-ambient thermal resistance	87.0	°C/W
$R_{\theta JC(top)}$	Junction-to-case (top) thermal resistance	33.3	°C/W
$R_{\theta JB}$	Junction-to-board thermal resistance	49.1	°C/W
$\Psi_{JT}$	Junction-to-top characterization parameter	8.4	°C/W
$\Psi_{JB}$	Junction-to-board characterization parameter	48.5	°C/W
$R_{\theta JC(bot)}$	Junction-to-case (bottom) thermal resistance	—	°C/W

(1) For more information about traditional and new thermal metrics, see the [Semiconductor and IC Package Thermal Metrics application report](#).

## 7.5 Power Ratings

PARAMETER		TEST CONDITIONS	MIN	TYP	MAX	UNIT
$P_D$	Maximum power dissipation (both sides)	$V_{CC1} = V_{CC2} = 5.5\text{ V}$ , $T_J = 150^\circ\text{C}$ , $C_L = 15\text{ pF}$ , Input a 1-MHz 50% duty cycle square wave			7.82	mW
$P_{D1}$	Maximum power dissipation (side-1)				4.46	mW
$P_{D2}$	Maximum power dissipation (side-2)				3.36	mW



## 7.6 Insulation Specifications

PARAMETER		TEST CONDITIONS	SPECIFICATIONS	UNIT
			QSOP-16	
<b>IEC 60664-1</b>				
CLR	External clearance <sup>(1)</sup>	Side 1 to side 2 distance through air	>3.7	mm
CPG	External creepage <sup>(1)</sup>	Side 1 to side 2 distance across package surface	>3.7	mm
DTI	Distance through the insulation	Minimum internal gap (internal clearance)	17	μm
CTI	Comparative tracking index	IEC 60112; UL 746A	>600	V
	Material Group		I	
	Overvoltage category	Rated mains voltage ≤ 300 V <sub>RMS</sub>	I-III	
<b>DIN VDE V 0884-11:2017-01<sup>(2)</sup></b>				
V <sub>IORM</sub>	Maximum repetitive peak isolation voltage	AC voltage (bipolar)	566	V <sub>PK</sub>
V <sub>IOWM</sub>	Maximum isolation working voltage	AC voltage (sine wave); time-dependent dielectric breakdown (TDDb) test; See <a href="#">Figure 17</a>	400	V <sub>RMS</sub>
		DC voltage	566	V <sub>DC</sub>
V <sub>IOTM</sub>	Maximum transient isolation voltage	V <sub>TEST</sub> = V <sub>IOTM</sub> , t = 60 s (qualification); V <sub>TEST</sub> = 1.2 × V <sub>IOTM</sub> , t = 1 s (100% production)	4242	V <sub>PK</sub>
V <sub>IOSM</sub>	Maximum surge isolation voltage <sup>(3)</sup>	Test method per IEC 62368-1, 1.2/50 μs waveform, V <sub>TEST</sub> = 1.6 × V <sub>IOSM</sub> = 6400 V <sub>PK</sub> (qualification)	4000	V <sub>PK</sub>
q <sub>pd</sub>	Apparent charge <sup>(4)</sup>	Method a: After I/O safety test subgroup 2/3, V <sub>ini</sub> = V <sub>IOTM</sub> , t <sub>ini</sub> = 60 s; V <sub>pd(m)</sub> = 1.2 × V <sub>IORM</sub> , t <sub>m</sub> = 10 s	≤ 5	pC
		Method a: After environmental tests subgroup 1, V <sub>ini</sub> = V <sub>IOTM</sub> , t <sub>ini</sub> = 60 s; V <sub>pd(m)</sub> = 1.6 × V <sub>IORM</sub> , t <sub>m</sub> = 10 s	≤ 5	
		Method b1: At routine test (100% production) and preconditioning (type test), V <sub>ini</sub> = V <sub>IOTM</sub> , t <sub>ini</sub> = 1 s; V <sub>pd(m)</sub> = 1.875 × V <sub>IORM</sub> , t <sub>m</sub> = 1 s	≤ 5	
C <sub>IO</sub>	Barrier capacitance, input to output <sup>(5)</sup>	V <sub>IO</sub> = 0.4 × sin(2πft), f = 1 MHz	~1.5	pF
R <sub>IO</sub>	Insulation resistance, input to output <sup>(5)</sup>	V <sub>IO</sub> = 500 V, T <sub>A</sub> = 25°C	> 10 <sup>12</sup>	Ω
		V <sub>IO</sub> = 500 V, 100°C ≤ T <sub>A</sub> ≤ 150°C	> 10 <sup>11</sup>	
		V <sub>IO</sub> = 500 V at T <sub>S</sub> = 150°C	> 10 <sup>9</sup>	
	Pollution degree		2	
	Climatic category		55/125/21	
<b>UL 1577</b>				
V <sub>ISO</sub>	Withstand isolation voltage	V <sub>TEST</sub> = V <sub>ISO</sub> , t = 60 s (qualification); V <sub>TEST</sub> = 1.2 × V <sub>ISO</sub> , t = 1 s (100% production)	3000	V <sub>RMS</sub>

- (1) Creepage and clearance requirements should be applied according to the specific equipment isolation standards of an application. Care should be taken to maintain the creepage and clearance distance of a board design to ensure that the mounting pads of the isolator on the printed-circuit board do not reduce this distance. Creepage and clearance on a printed-circuit board become equal in certain cases. Techniques such as inserting grooves, ribs, or both on a printed circuit board are used to help increase these specifications.
- (2) This coupler is suitable for *safe electrical insulation* only within the safety ratings. Compliance with the safety ratings shall be ensured by means of suitable protective circuits.
- (3) Testing is carried out in air or oil to determine the intrinsic surge immunity of the isolation barrier.
- (4) Apparent charge is electrical discharge caused by a partial discharge (pd).
- (5) All pins on each side of the barrier tied together creating a two-pin device.

## 7.7 Safety-Related Certifications

VDE	CSA	UL	CQC	TUV	CSA/Sira
Certified according to DIN VDE V 0884-11:2017- 01	Certified according to IEC 60950-1 and IEC 62368-1	Certified according to UL 1577 Component Recognition Program	Certified according to GB4943.1-2011	Certified according to EN 61010-1:2010/A1:2019, EN 60950-1:2006/A2:2013 and EN 62368-1:2014	Certified for use in intrinsic safety (IS) to IS applications under ATEX and IECEx.
Maximum transient isolation voltage, 4242 V <sub>PK</sub> ; Maximum repetitive peak isolation voltage, 566 V <sub>PK</sub> ; Maximum surge isolation voltage, 4000 V <sub>PK</sub>	3000 V <sub>RMS</sub> insulation per CSA 60950-1-07+A1+A2, IEC 60950-1 2nd Ed.+A1+A2, CSA 62368-1- 14 and IEC 62368-1:2014 370 V <sub>RMS</sub> (DBQ-16) maximum working voltage (pollution degree 2, material group I)	Single protection, 3000 V <sub>RMS</sub>	Basic insulation, Altitude ≤ 5000 m, Tropical Climate, 400 V <sub>RMS</sub> maximum working voltage	EN 61010-1:2010/A1:2019, 300 V <sub>RMS</sub> basic isolation EN 60950-1:2006/A2:2013 and EN 62368-1:2014, 400 V <sub>RMS</sub> basic isolation	ATEX: EN 60079-0:2018 and EN 60079-11:2012 IECEX: IEC 60079-0:2017 (7th Ed) and IEC60079-11:2011 (6th Ed) Markings: II 1G Ex ia IIC Ga See the <a href="#">Intrinsic Safety section</a>
Certificate number: 40040142	Master contract number: 220991	File number: E181974	Certificate: CQC18001199097	Client ID number: 77311	IECEX certificate: IECEX CSA 19.0040U ATEX certificate: CSANe 20ATEX2003U

## 7.8 Safety Limiting Values

Safety limiting<sup>(1)</sup> intends to minimize potential damage to the isolation barrier upon failure of input or output circuitry.

PARAMETER		TEST CONDITIONS	MIN	TYP	MAX	UNIT
<b>16-QSOP PACKAGE</b>						
I <sub>S</sub>	Safety input, output, or supply current	R <sub>θJA</sub> = 87°C/W, V <sub>I</sub> = 5.5 V, T <sub>J</sub> = 150°C, T <sub>A</sub> = 25°C			261	mA
		R <sub>θJA</sub> = 87°C/W, V <sub>I</sub> = 3.6 V, T <sub>J</sub> = 150°C, T <sub>A</sub> = 25°C			399	mA
		R <sub>θJA</sub> = 87°C/W, V <sub>I</sub> = 2.75 V, T <sub>J</sub> = 150°C, T <sub>A</sub> = 25°C			522	
		R <sub>θJA</sub> = 87°C/W, V <sub>I</sub> = 1.89 V, T <sub>J</sub> = 150°C, T <sub>A</sub> = 25°C			760	mA
P <sub>S</sub>	Safety input, output, or total power	R <sub>θJA</sub> = 87°C/W, T <sub>J</sub> = 150°C, T <sub>A</sub> = 25°C			1435	mW
T <sub>S</sub>	Maximum safety temperature				150	°C

(1) The maximum safety temperature, T<sub>S</sub>, has the same value as the maximum junction temperature, T<sub>J</sub>, specified for the device. The I<sub>S</sub> and P<sub>S</sub> parameters represent the safety current and safety power respectively. The maximum limits of I<sub>S</sub> and P<sub>S</sub> should not be exceeded. These limits vary with the ambient temperature, T<sub>A</sub>.

The junction-to-air thermal resistance, R<sub>θJA</sub>, in the table is that of a device installed on a high-K test board for leaded surface-mount packages. Use these equations to calculate the value for each parameter:

T<sub>J</sub> = T<sub>A</sub> + R<sub>θJA</sub> × P, where P is the power dissipated in the device.

T<sub>J(max)</sub> = T<sub>S</sub> = T<sub>A</sub> + R<sub>θJA</sub> × P<sub>S</sub>, where T<sub>J(max)</sub> is the maximum allowed junction temperature.

P<sub>S</sub> = I<sub>S</sub> × V<sub>I</sub>, where V<sub>I</sub> is the maximum input voltage.

## 7.9 Electrical Characteristics 5V Supply

over operating free-air temperature range (unless otherwise noted)

PARAMETER		TEST CONDITIONS	MIN	TYP	MAX	UNIT
$V_{IT+(IN)}$	Rising input switching threshold				$0.7 \times V_{CCI}^{(1)}$	V
$V_{IT-(IN)}$	Falling input switching threshold		$0.3 \times V_{CCI}$			V
$V_{OH}$	High-level output voltage	$I_{OH} = -4 \text{ mA}$	$V_{CCO} - 0.4$			V
$V_{OL}$	Low-level output voltage	$I_{OL} = 4 \text{ mA}$			0.4	V
$V_{I(HYS)}$	Input threshold voltage hysteresis		$0.1 \times V_{CCI}$			V
$I_{IH}$	High-level input current	$V_{IH} = V_{CCI}^{(1)}$ at INx			1	$\mu\text{A}$
$I_{IL}$	Low-level input current	$V_{IL} = 0 \text{ V}$ at INx	-1			$\mu\text{A}$
CMTI	Common mode transient immunity	$V_I = V_{CC}$ or 0 V, $V_{CM} = 1200 \text{ V}$	50	100		kV/us
$C_i$	Input Capacitance <sup>(2)</sup>	$V_I = V_{CC}/2 + 0.4 \times \sin(2\pi ft)$ , $f = 1 \text{ MHz}$ , $V_{CC} = 5 \text{ V}$		2		pF

(1)  $V_{CCI}$  = Input-side  $V_{CC}$ ;  $V_{CCO}$  = Output-side  $V_{CC}$ 

(2) Measured from input pin to same side ground.

## 7.10 Supply Current Characteristics 5V Supply

over operating free-air temperature range (unless otherwise noted)

PARAMETER	TEST CONDITIONS	SUPPLY CURRENT	MIN	TYP	MAX	UNIT
<b>ISO7041</b>						
Supply current - DC signal	Refresh disable	$I_{CC1}$		6.2	14.3	$\mu\text{A}$
		$I_{CC2}$		10.1	18.5	$\mu\text{A}$
	Refresh enable $V_I = V_{CC1}$ (ISO7041); $V_I = 0 \text{ V}$ (ISO7041 with F suffix)	$I_{CC1}$		8.2	16.7	$\mu\text{A}$
		$I_{CC2}$		10.8	18.5	$\mu\text{A}$
	Refresh enable $V_I = 0 \text{ V}$ (ISO7041); $V_I = V_{CC1}$ (ISO7041 with F suffix)	$I_{CC1}$		9.5	19.9	$\mu\text{A}$
		$I_{CC2}$		11.3	19.5	$\mu\text{A}$
Supply current - AC signal	Refresh disable 10 kbps, No Load	$I_{CC1}$		6.7	19.7	$\mu\text{A}$
		$I_{CC2}$		11.8	20.6	$\mu\text{A}$
	Refresh disable 100 kbps, No Load	$I_{CC1}$		37.1	57.4	$\mu\text{A}$
		$I_{CC2}$		25.8	37.7	$\mu\text{A}$
	Refresh disable 1 Mbps, No Load	$I_{CC1}$		340.5	436.1	$\mu\text{A}$
		$I_{CC2}$		167.0	211.1	$\mu\text{A}$
	Refresh enable 10 kbps, No Load	$I_{CC1}$		10.6	20.8	$\mu\text{A}$
		$I_{CC2}$		11.9	20.4	$\mu\text{A}$
	Refresh enable 100 kbps, No Load	$I_{CC1}$		37.1	57.4	$\mu\text{A}$
		$I_{CC2}$		25.8	37.7	$\mu\text{A}$
	Refresh enable 1 Mbps, No Load	$I_{CC1}$		338.3	436.1	$\mu\text{A}$
		$I_{CC2}$		166.0	211.1	$\mu\text{A}$
Total Supply Current Per Channel, Refresh Disabled	DC Signal	$I_{CC1(ch)} + I_{CC2(ch)}$		4.1	7.4	$\mu\text{A}$
	10 kbps, No Load	$I_{CC1(ch)} + I_{CC2(ch)}$		5.9	10.7	$\mu\text{A}$
	100 kbps, No Load	$I_{CC1(ch)} + I_{CC2(ch)}$		17.4	23.4	$\mu\text{A}$
	1 Mbps, No Load	$I_{CC1(ch)} + I_{CC2(ch)}$		137.0	164.5	$\mu\text{A}$

**Supply Current Characteristics 5V Supply (continued)**

over operating free-air temperature range (unless otherwise noted)

PARAMETER	TEST CONDITIONS	SUPPLY CURRENT	MIN	TYP	MAX	UNIT
Total Supply Current Per Channel, Refresh Enabled	$V_I = V_{CC1}$ (ISO7041); $V_I = 0$ V (ISO7041 with F suffix)	$I_{CC1(ch)} + I_{CC2(ch)}$		4.8	8.5	$\mu$ A
	$V_I = 0$ V (ISO7041); $V_I = V_{CC1}$ (ISO7041 with F suffix)	$I_{CC1(ch)} + I_{CC2(ch)}$		5.3	9.6	$\mu$ A
	10 kbps, No Load	$I_{CC1(ch)} + I_{CC2(ch)}$		5.7	10.4	$\mu$ A
	100 kbps, No Load	$I_{CC1(ch)} + I_{CC2(ch)}$		16.4	22.3	$\mu$ A
	1 Mbps, No Load	$I_{CC1(ch)} + I_{CC2(ch)}$		125.9	154.0	$\mu$ A

## 7.11 Electrical Characteristics 3.3V Supply

over operating free-air temperature range (unless otherwise noted)

PARAMETER		TEST CONDITIONS	MIN	TYP	MAX	UNIT
$V_{IT+(IN)}$	Rising input switching threshold				$0.7 \times V_{CC1}^{(1)}$	V
$V_{IT-(IN)}$	Falling input switching threshold		$0.3 \times V_{CC1}$			V
$V_{OH}$	High-level output voltage	$I_{OH} = -2\text{mA}$	$V_{CCO} - 0.3$	$V_{CCO} - 0.2$		V
$V_{OL}$	Low-level output voltage	$I_{OL} = 2\text{mA}$		0.2	0.3	V
$V_{I(HYS)}$	Input threshold voltage hysteresis		$0.1 \times V_{CC1}$			V
$I_{IH}$	High-level input current	$V_{IH} = V_{CC1}^{(1)}$ at INx			1	$\mu\text{A}$
$I_{IL}$	Low-level input current	$V_{IL} = 0\text{ V}$ at INx	-1			$\mu\text{A}$
CMTI	Common mode transient immunity	$V_I = V_{CC}$ or 0 V, $V_{CM} = 1200\text{ V}$	50	100		kV/us
$C_i$	Input Capacitance <sup>(2)</sup>	$V_I = V_{CC}/2 + 0.4 \times \sin(2\pi ft)$ , $f = 1\text{ MHz}$ , $V_{CC} = 3.6\text{ V}$		2		pF

(1)  $V_{CC1}$  = Input-side  $V_{CC}$ ;  $V_{CCO}$  = Output-side  $V_{CC}$ 

(2) Measured from input pin to same side ground.

## 7.12 Supply Current Characteristics 3.3V Supply

over operating free-air temperature range (unless otherwise noted)

PARAMETER	TEST CONDITIONS	SUPPLY CURRENT	MIN	TYP	MAX	UNIT
<b>ISO7041</b>						
Supply current - DC signal	Refresh disable	$I_{CC1}$		5.1	8.8	$\mu\text{A}$
		$I_{CC2}$		8.9	14.0	$\mu\text{A}$
	Refresh enable $V_I = V_{CC1}$ (ISO7041); $V_I = 0\text{ V}$ (ISO7041 with F suffix)	$I_{CC1}$		6.8	12.2	$\mu\text{A}$
		$I_{CC2}$		9.6	14.0	$\mu\text{A}$
	Refresh enable $V_I = 0\text{ V}$ (ISO7041); $V_I = V_{CC1}$ (ISO7041 with F suffix)	$I_{CC1}$		8.1	14.8	$\mu\text{A}$
		$I_{CC2}$		10.0	15.6	$\mu\text{A}$
Supply current - AC signal	Refresh disable 10 kbps, No Load	$I_{CC1}$		7.9	13.7	$\mu\text{A}$
		$I_{CC2}$		10.4	15.9	$\mu\text{A}$
	Refresh disable 100 kbps, No Load	$I_{CC1}$		35.9	48.3	$\mu\text{A}$
		$I_{CC2}$		22.7	31.4	$\mu\text{A}$
	Refresh disable 1 Mbps, No Load	$I_{CC1}$		316.4	395.7	$\mu\text{A}$
		$I_{CC2}$		147.2	188.2	$\mu\text{A}$
	Refresh enable 10 kbps, No Load	$I_{CC1}$		9.8	16.4	$\mu\text{A}$
		$I_{CC2}$		10.5	16.2	$\mu\text{A}$
	Refresh enable 100 kbps, No Load	$I_{CC1}$		35.9	48.3	$\mu\text{A}$
		$I_{CC2}$		22.7	31.4	$\mu\text{A}$
	Refresh enable 1 Mbps, No Load	$I_{CC1}$		315.3	395.7	$\mu\text{A}$
		$I_{CC2}$		146.2	188.2	$\mu\text{A}$
Total Supply Current Per Channel, Refresh Disabled	DC Signal	$I_{CC1(ch)} + I_{CC2(ch)}$		3.5	5.7	$\mu\text{A}$
	10 kbps, No Load	$I_{CC1(ch)} + I_{CC2(ch)}$		5.2	8.2	$\mu\text{A}$
	100 kbps, No Load	$I_{CC1(ch)} + I_{CC2(ch)}$		14.8	19.2	$\mu\text{A}$
	1 Mbps, No Load	$I_{CC1(ch)} + I_{CC2(ch)}$		115.7	138.7	$\mu\text{A}$

**Supply Current Characteristics 3.3V Supply (continued)**

over operating free-air temperature range (unless otherwise noted)

PARAMETER	TEST CONDITIONS	SUPPLY CURRENT	MIN	TYP	MAX	UNIT
Total Supply Current Per Channel, Refresh Enabled	$V_I = V_{CC1}$ (ISO7041); $V_I = 0$ V (ISO7041 with F suffix)	$I_{CC1(ch)} + I_{CC2(ch)}$		4.2	6.8	$\mu$ A
	$V_I = 0$ V (ISO7041); $V_I = V_{CC1}$ (ISO7041 with F suffix)	$I_{CC1(ch)} + I_{CC2(ch)}$		4.6	7.7	$\mu$ A
	10 kbps, No Load	$I_{CC1(ch)} + I_{CC2(ch)}$		5.2	8.2	$\mu$ A
	100 kbps, No Load	$I_{CC1(ch)} + I_{CC2(ch)}$		14.8	19.2	$\mu$ A
	1 Mbps, No Load	$I_{CC1(ch)} + I_{CC2(ch)}$		115.7	138.7	$\mu$ A

### 7.13 Electrical Characteristics 2.5V Supply

over operating free-air temperature range (unless otherwise noted)

PARAMETER		TEST CONDITIONS	MIN	TYP	MAX	UNIT
$V_{IT+(IN)}$	Rising input switching threshold				$0.7 \times V_{CC1}^{(1)}$	V
$V_{IT-(IN)}$	Falling input switching threshold		$0.3 \times V_{CC1}$			V
$V_{OH}$	High-level output voltage	$I_{OH} = -1\text{mA}$	$V_{CCO} - 0.2$			V
$V_{OL}$	Low-level output voltage	$I_{OL} = 1\text{mA}$			0.2	V
$V_{I(HYS)}$	Input threshold voltage hysteresis		$0.1 \times V_{CC1}$			V
$I_{IH}$	High-level input current	$V_{IH} = V_{CC1}^{(1)}$ at INx			1	$\mu\text{A}$
$I_{IL}$	Low-level input current	$V_{IL} = 0\text{V}$ at INx	-1			$\mu\text{A}$
CMTI	Common mode transient immunity	$V_I = V_{CC}$ or $0\text{V}$ , $V_{CM} = 1200\text{V}$	50	100		kV/us

 (1)  $V_{CC1}$  = Input-side  $V_{CC}$ ;  $V_{CCO}$  = Output-side  $V_{CC}$ 

### 7.14 Supply Current Characteristics 2.5V Supply

over operating free-air temperature range (unless otherwise noted)

PARAMETER	TEST CONDITIONS	SUPPLY CURRENT	MIN	TYP	MAX	UNIT
<b>ISO7041</b>						
Supply current - DC signal	Refresh disable	$I_{CC1}$		4.7	8.2	$\mu\text{A}$
		$I_{CC2}$		8.6	13.0	$\mu\text{A}$
	Refresh enable $V_I = V_{CC1}$ (ISO7041); $V_I = 0\text{V}$ (ISO7041 with F suffix)	$I_{CC1}$		6.4	10.9	$\mu\text{A}$
		$I_{CC2}$		9.2	13.0	$\mu\text{A}$
Supply current - AC signal	Refresh enable $V_I = 0\text{V}$ (ISO7041); $V_I = V_{CC1}$ (ISO7041 with F suffix)	$I_{CC1}$		7.6	13.2	$\mu\text{A}$
		$I_{CC2}$		9.6	14.6	$\mu\text{A}$
	Refresh disable 10 kbps, No Load	$I_{CC1}$		8.2	12.2	$\mu\text{A}$
		$I_{CC2}$		10.0	14.8	$\mu\text{A}$
	Refresh disable 100 kbps, No Load	$I_{CC1}$		34.7	44.5	$\mu\text{A}$
		$I_{CC2}$		21.3	29.0	$\mu\text{A}$
	Refresh disable 1 Mbps, No Load	$I_{CC1}$		301.5	367.4	$\mu\text{A}$
		$I_{CC2}$		137.0	173.3	$\mu\text{A}$
	Refresh enable 10 kbps, No Load	$I_{CC1}$		9.9	14.6	$\mu\text{A}$
		$I_{CC2}$		10.0	15.9	$\mu\text{A}$
	Refresh enable 100 kbps, No Load	$I_{CC1}$		34.7	44.5	$\mu\text{A}$
		$I_{CC2}$		21.3	29.0	$\mu\text{A}$
Refresh enable 1 Mbps, No Load	$I_{CC1}$		304.8	367.4	$\mu\text{A}$	
	$I_{CC2}$		136.0	173.3	$\mu\text{A}$	
Total Supply Current Per Channel, Refresh Disabled	DC Signal	$I_{CC1(ch)} + I_{CC2(ch)}$		3.3	5.3	$\mu\text{A}$
	10 kbps, No Load	$I_{CC1(ch)} + I_{CC2(ch)}$		5.0	7.5	$\mu\text{A}$
	100 kbps, No Load	$I_{CC1(ch)} + I_{CC2(ch)}$		14.0	17.6	$\mu\text{A}$
	1 Mbps, No Load	$I_{CC1(ch)} + I_{CC2(ch)}$		110.0	127.1	$\mu\text{A}$
Total Supply Current Per Channel, Refresh Enabled	$V_I = V_{CC1}$ (ISO7041); $V_I = 0\text{V}$ (ISO7041 with F suffix)	$I_{CC1(ch)} + I_{CC2(ch)}$		4.0	6.2	$\mu\text{A}$
		$I_{CC1(ch)} + I_{CC2(ch)}$		4.4	7.0	$\mu\text{A}$
	10 kbps, No Load	$I_{CC1(ch)} + I_{CC2(ch)}$		5.0	7.5	$\mu\text{A}$
	100 kbps, No Load	$I_{CC1(ch)} + I_{CC2(ch)}$		14.0	17.6	$\mu\text{A}$
	1 Mbps, No Load	$I_{CC1(ch)} + I_{CC2(ch)}$		110	127.1	$\mu\text{A}$

## 7.15 Electrical Characteristics 1.8V Supply

over operating free-air temperature range (unless otherwise noted)

PARAMETER		TEST CONDITIONS	MIN	TYP	MAX	UNIT
$V_{IT+(IN)}$	Rising input switching threshold			$0.7 \times V_{CCI}^{(1)}$		V
$V_{IT-(IN)}$	Falling input switching threshold		$0.3 \times V_{CCI}$			V
$V_{OH}$	High-level output voltage	$I_{OH} = -1\text{mA}$	$V_{CCO} - 0.2$			V
$V_{OL}$	Low-level output voltage	$I_{OL} = 1\text{mA}$			0.2	V
$V_{I(HYS)}$	Input threshold voltage hysteresis		$0.1 \times V_{CCI}$			V
$I_{IH}$	High-level input current	$V_{IH} = V_{CCI}^{(1)}$ at INx			1	$\mu\text{A}$
$I_{IL}$	Low-level input current	$V_{IL} = 0\text{V}$ at INx	-1			$\mu\text{A}$
CMTI	Common mode transient immunity	$V_I = V_{CC}$ or 0 V, $V_{CM} = 1200\text{V}$	50	100		kV/us

 (1)  $V_{CCI}$  = Input-side  $V_{CC}$ ;  $V_{CCO}$  = Output-side  $V_{CC}$ 

## 7.16 Supply Current Characteristics 1.8V Supply

over operating free-air temperature range (unless otherwise noted)

PARAMETER	TEST CONDITIONS	SUPPLY CURRENT	MIN	TYP	MAX	UNIT	
<b>ISO7041</b>							
Supply current - DC signal	Refresh disable	$I_{CC1}$		3.7	7.5	$\mu\text{A}$	
		$I_{CC2}$		7.9	13.3	$\mu\text{A}$	
	Refresh enable $V_I = V_{CCI}^{(1)}$ (ISO7041); $V_I = 0\text{V}$ (ISO7041 with F suffix)	$I_{CC1}$		5.1	9.6	$\mu\text{A}$	
		$I_{CC2}$		8.6	14.1	$\mu\text{A}$	
	Refresh enable $V_I = 0\text{V}$ (ISO7041); $V_I = V_{CCI}$ (ISO7041 with F suffix)	$I_{CC1}$		6.3	11.5	$\mu\text{A}$	
		$I_{CC2}$		9.0	14.7	$\mu\text{A}$	
	Supply current - AC signal	Refresh disable 10 kbps, No Load	$I_{CC1}$		9.3	10.9	$\mu\text{A}$
			$I_{CC2}$		9.3	15.2	$\mu\text{A}$
Refresh disable 100 kbps, No Load		$I_{CC1}$		31.7	40.6	$\mu\text{A}$	
		$I_{CC2}$		21.2	31.0	$\mu\text{A}$	
Refresh disable 1 Mbps, No Load		$I_{CC1}$		255.2	338.4	$\mu\text{A}$	
		$I_{CC2}$		140.8	190.8	$\mu\text{A}$	
Refresh enable 10 kbps, No Load		$I_{CC1}$		7	12.9	$\mu\text{A}$	
		$I_{CC2}$		9.5	15	$\mu\text{A}$	
Refresh enable 100 kbps, No Load		$I_{CC1}$		31.6	40.6	$\mu\text{A}$	
		$I_{CC2}$		21.2	31.0	$\mu\text{A}$	
Refresh enable 1 Mbps, No Load		$I_{CC1}$		256.3	338.4	$\mu\text{A}$	
		$I_{CC2}$		140.8	190.8	$\mu\text{A}$	
Total Supply Current Per Channel, Refresh Disabled	DC Signal	$I_{CC1(ch)} + I_{CC2(ch)}$		2.8	5.2	$\mu\text{A}$	
	10 kbps, No Load	$I_{CC1(ch)} + I_{CC2(ch)}$		3.8	6.4	$\mu\text{A}$	
	100 kbps, No Load	$I_{CC1(ch)} + I_{CC2(ch)}$		12.5	17.1	$\mu\text{A}$	
	1 Mbps, No Load	$I_{CC1(ch)} + I_{CC2(ch)}$		99	124.8	$\mu\text{A}$	
Total Supply Current Per Channel, Refresh Enabled	$V_I = V_{CCI}$ (ISO7041); $V_I = 0\text{V}$ (ISO7041 with F suffix)	$I_{CC1(ch)} + I_{CC2(ch)}$		3.4	8	$\mu\text{A}$	
		$I_{CC1(ch)} + I_{CC2(ch)}$		3.8	8.9	$\mu\text{A}$	
	10 kbps, No Load	$I_{CC1(ch)} + I_{CC2(ch)}$		4.1	6.8	$\mu\text{A}$	
		$I_{CC1(ch)} + I_{CC2(ch)}$		12.5	17.1	$\mu\text{A}$	
	1 Mbps, No Load	$I_{CC1(ch)} + I_{CC2(ch)}$		99.3	124.8	$\mu\text{A}$	

 (1)  $V_{CCI}$  = Input-side  $V_{CC}$



## 7.17 Switching Characteristics

 $V_{CC1}, V_{CC2} = 1.71\text{ V to }1.89\text{ V or }2.25\text{ V to }5.5\text{ V}$  (over recommended operating conditions unless otherwise noted)

PARAMETER		TEST CONDITIONS	MIN	TYP	MAX	UNIT
$t_{PLH}, t_{PHL}$	Propagation delay time	See <a href="#">Figure 11</a>		140	175	ns
				140	165	ns
$t_{P(dft)}$	Propagation delay drift			15		ps/°C
$t_{UI}$	Minimum pulse width	See <a href="#">Figure 11</a>	250			ns
PWD	Pulse width distortion				10	ns
$t_{sk(o)}$	Channel to channel output skew time	Same-direction channels			10	ns
		Opposite-direction channels			10	ns
$t_{sk(p-p)}$	Part to part skew time				70	ns
$t_r$	Output signal rise time	$V_{CC1}, V_{CC2} = 1.71\text{ V to }1.89\text{ V}$ . See <a href="#">Figure 11</a>			8	ns
		$V_{CC1}, V_{CC2} = 2.25\text{ V to }5.5\text{ V}$ . See <a href="#">Figure 11</a>			5	ns
$t_f$	Output signal fall time	$V_{CC1}, V_{CC2} = 1.71\text{ V to }1.89\text{ V}$ . See <a href="#">Figure 11</a>			8	ns
		$V_{CC1}, V_{CC2} = 2.25\text{ V to }5.5\text{ V}$ . See <a href="#">Figure 11</a>			5	ns
$t_{DO}$	Default output delay time from input power loss	Refresh enabled, See <a href="#">Figure 12</a>		400	750	us
$t_{PU}$	Time from UVLO to valid output data		1		5	ms
$F_R$	Refresh rate		5	10		kbps

### 7.18 Insulation Characteristics Curves

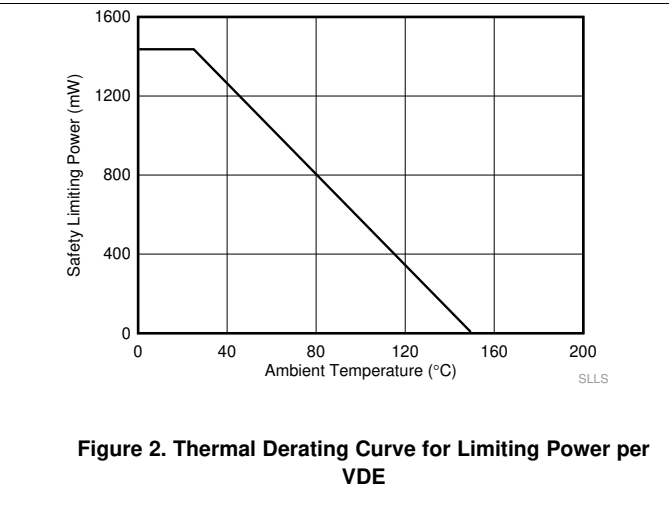
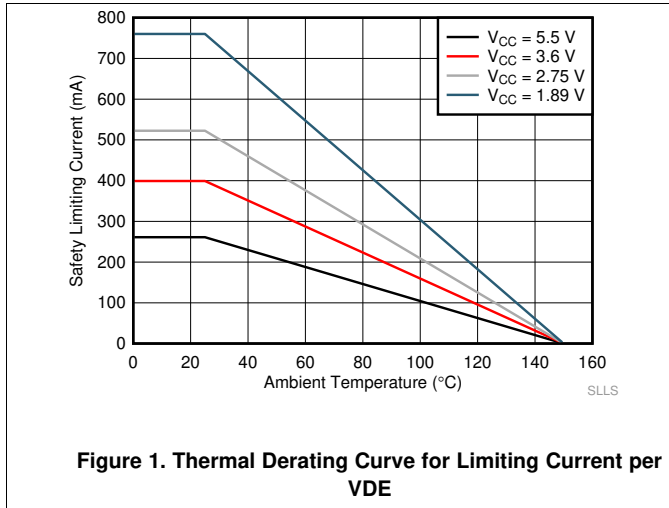

### 7.19 Typical Characteristics

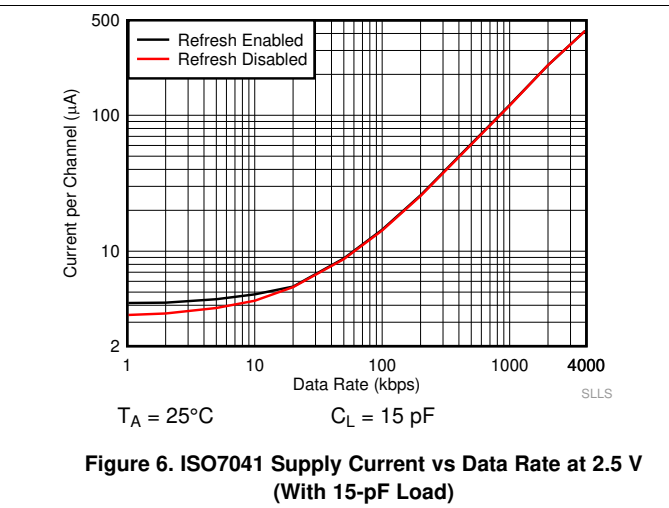
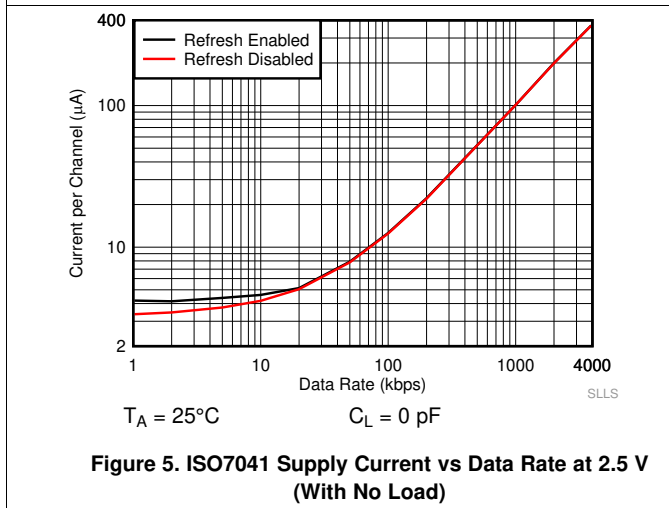
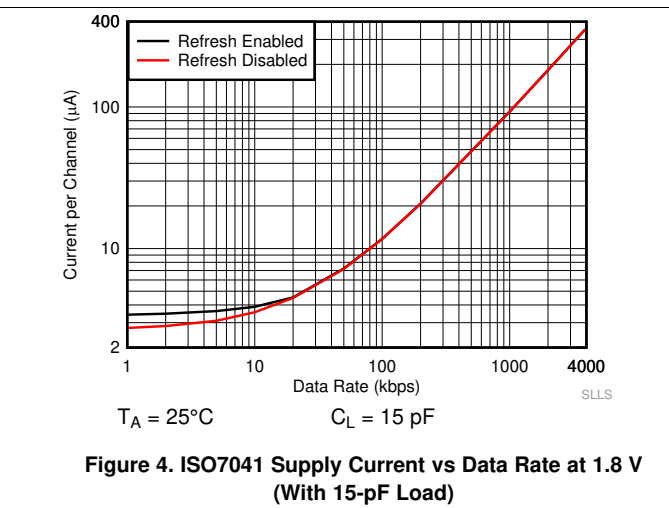
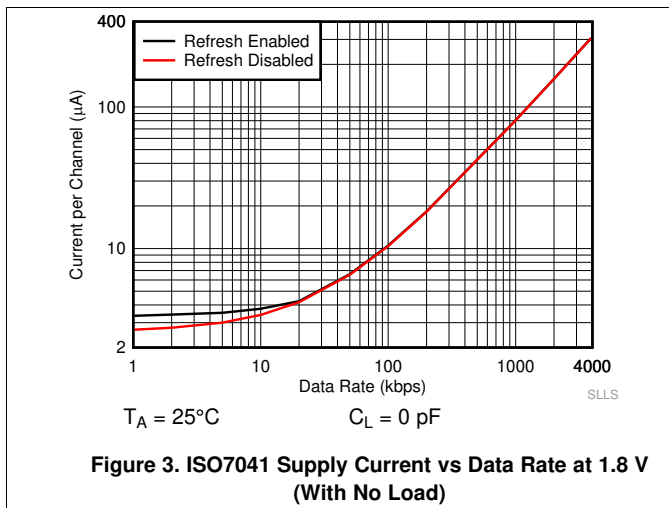

Typical Characteristics (continued)

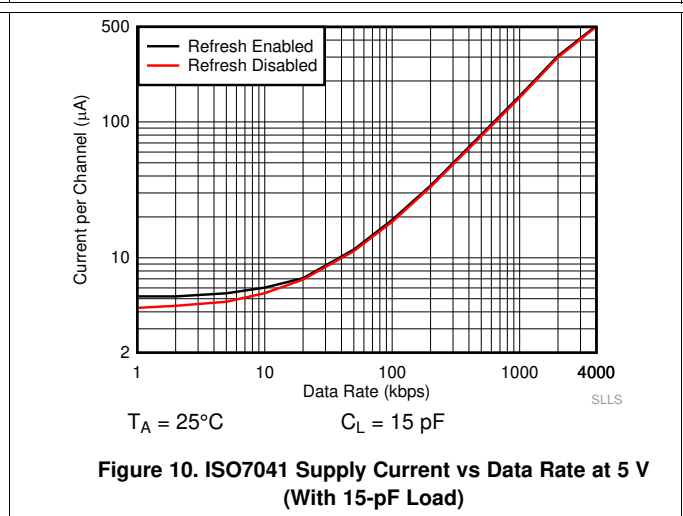
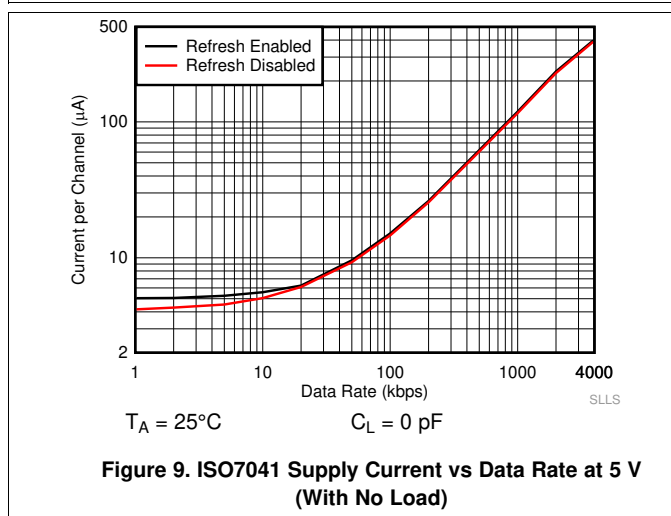
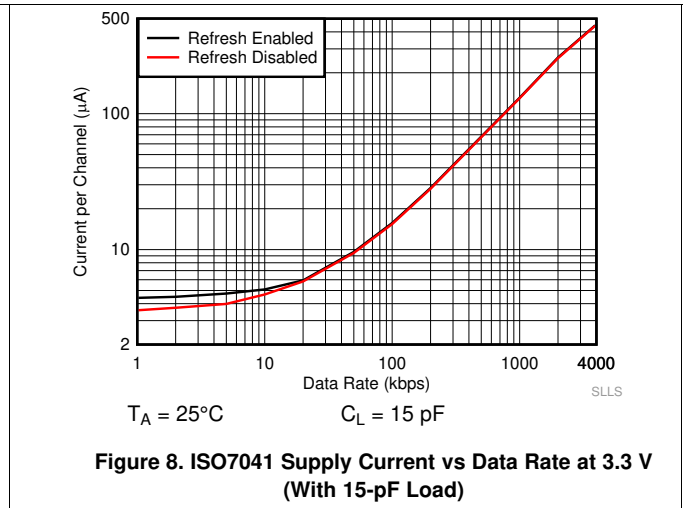
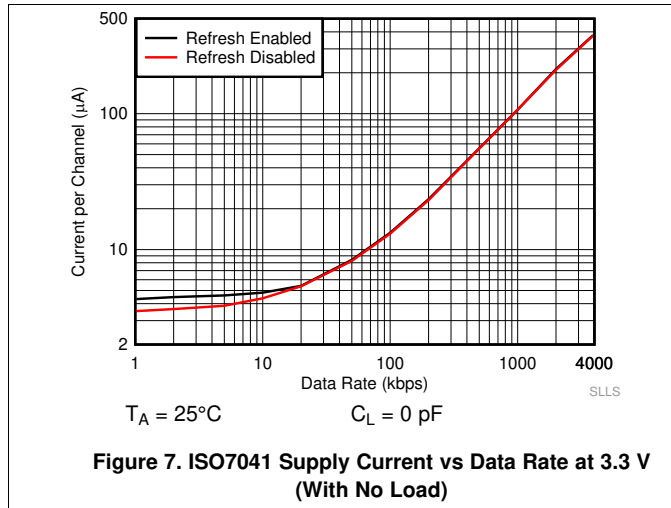

## 8 Parameter Measurement Information

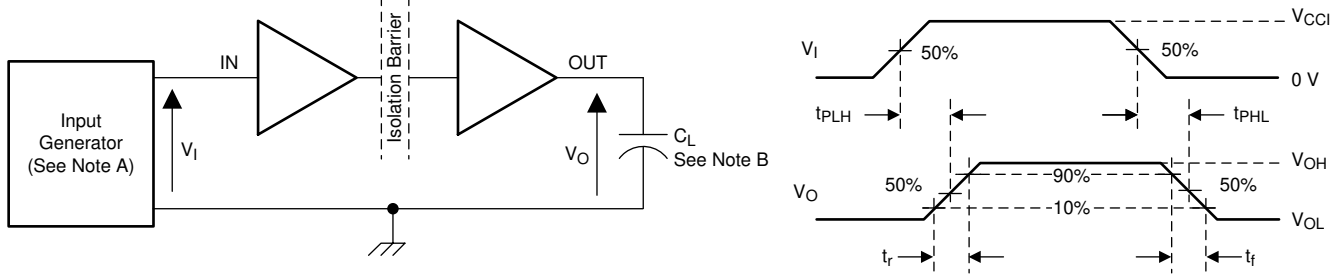

- A. The input pulse is supplied by a generator having the following characteristics:  $PRR \leq 50$  kHz, 50% duty cycle,  $t_r \leq 3$  ns,  $t_f \leq 3$  ns,  $Z_O = 50 \Omega$ . At the input,  $50 \Omega$  resistor is required to terminate Input Generator signal. It is not needed in actual application.
- B.  $C_L = 15$  pF and includes instrumentation and fixture capacitance within  $\pm 20\%$ .

**Figure 11. Switching Characteristics Test Circuit and Voltage Waveforms**

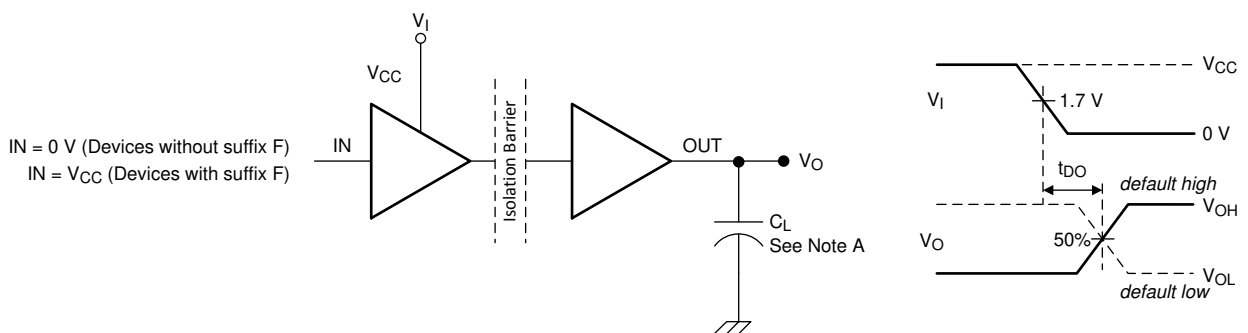

- A.  $C_L = 15$  pF and includes instrumentation and fixture capacitance within  $\pm 20\%$ .
- B. Power Supply Ramp Rate = 10 mV/ns

**Figure 12. Default Output Delay Time Test Circuit and Voltage Waveforms**

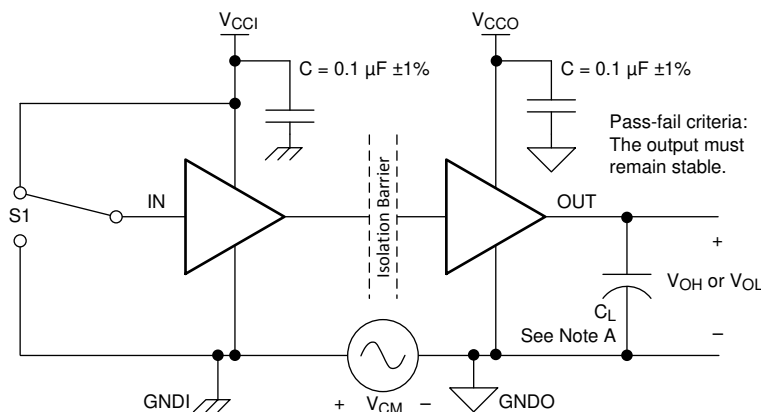

- A.  $C_L = 15$  pF and includes instrumentation and fixture capacitance within  $\pm 20\%$ .

**Figure 13. Common-Mode Transient Immunity Test Circuit**

## 9 Detailed Description

### 9.1 Overview

The ISO7041 device uses edge encoding of data with an ON-OFF keying (OOK) modulation scheme to transmit the digital data across a silicon dioxide isolation barrier. The transmitter uses a high frequency carrier signal to pass data across the barrier representing a signal edge transition. Using this method achieves very low power consumption and high immunity. The receiver demodulates the carrier signal after advanced signal conditioning and produces the output through a buffer stage. For low data rates, a refresh logic option is available to make sure the output state matches the input state. The ENx pins of side A and side B must be tied low to enable refresh or high to disable refresh. Advanced circuit techniques are used to maximize the CMTI performance and minimize the radiated emissions due to the high frequency carrier and IO buffer switching. The conceptual block diagram of a digital capacitive isolator, [Figure 14](#), shows a functional block diagram of a typical channel.

### 9.2 Functional Block Diagram

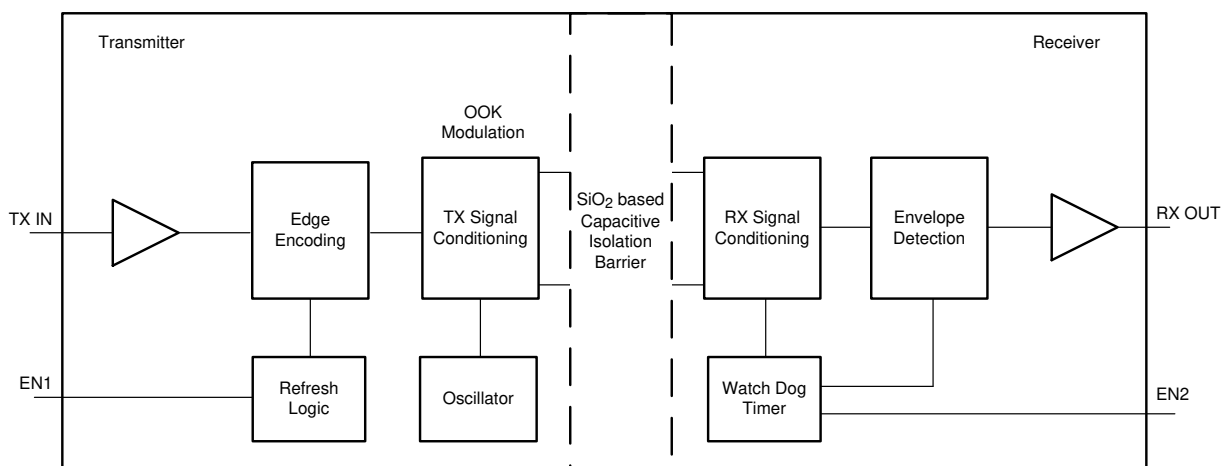

**Figure 14. Conceptual Block Diagram of a Digital Capacitive Isolator**

### 9.3 Feature Description

#### 9.3.1 Refresh Enable

The ISO7041 uses an edge based encoding scheme to transfer an input signal change across the isolation barrier versus sending across the DC state. Enabling the refresh feature consistently validates that the DC output state of each isolator channel matches the DC input state. An internal watchdog timer monitors for activity on the individual inputs and transmits the logic state when there is no input signal transition for more than 100  $\mu$ s. This ensures that the input and output state of the isolator always match. Tie both EN1 and EN2 to their respective grounds to enable refresh.

Disable refresh by tying both EN1 and EN2 to their respective VCC power supplies. Disabling refresh will further decrease the power consumption of the device but the DC state is not guaranteed at startup. System level solutions can be implemented to ensure the isolator channel output matches the input at startup. For example, at start up, an immediate full transition of the input signals from high to low and low to high on the individual isolator lines would allow the states of the outputs to properly track the inputs.

## Feature Description (continued)

### 9.3.2 Electromagnetic Compatibility (EMC) Considerations

Many applications in harsh industrial environment are sensitive to disturbances such as electrostatic discharge (ESD), electrical fast transient (EFT), surge and electromagnetic emissions. These electromagnetic disturbances are regulated by international standards such as IEC 61000-4-x and CISPR 22. Although system-level performance and reliability depends, to a large extent, on the application board design and layout, the ISO70xx family of devices incorporates many chip-level design improvements for overall system robustness. Some of these improvements include:

- Robust ESD protection cells for input and output signal pins and inter-chip bond pads.
- Low-resistance connectivity of ESD cells to supply and ground pins.
- Enhanced performance of high voltage isolation capacitor for better tolerance of ESD, EFT and surge events.
- Bigger on-chip decoupling capacitors to bypass undesirable high energy signals through a low impedance path.
- PMOS and NMOS devices isolated from each other by using guard rings to avoid triggering of parasitic SCRs.
- Reduced common mode currents across the isolation barrier by ensuring purely differential internal operation.

The device has no issue being able to meet either CISPR 22 Class A and CISPR22 Class B standards in an unshielded environment.

## 9.4 Device Functional Modes

shows the functional modes for the device.

**Table 2. Function Table<sup>(1)</sup>**

$V_{CCI}$	$V_{CCO}$	INPUT (INx) <sup>(2)</sup>	REFRESH ENABLE (ENx)	OUTPUT (OUTx)	COMMENTS
PU	PU	H	L	H	Normal Operation: A channel output assumes the logic state of its input.
		L	L	L	
		X	H	Undetermined	The device needs an input signal transition to validate the output tracks the input state. Without a signal edge transition, the output will be in an undetermined state.
PD	PU	X	L	Default	When $V_{CCI}$ is unpowered, a channel output assumes the logic state based on the selected default option. Default is <i>High</i> for the device without the F suffix and <i>Low</i> for device with the F suffix. When $V_{CCI}$ transitions from unpowered to powered-up, a channel output assumes the logic state of the input. When $V_{CCI}$ transitions from powered-up to unpowered, channel output assumes the selected default state.
			H	Undetermined	When $V_{CCI}$ is unpowered, a channel output assumes the logic state based on the previous state of the output before $V_{CCI}$ powered down.
X	PD	X	L	Undetermined	When $V_{CCO}$ is unpowered, a channel output is undetermined <sup>(3)</sup> . When $V_{CCO}$ transitions from unpowered to powered-up, a channel output assumes the logic state of the input.
			H	Undetermined	When $V_{CCO}$ is unpowered, a channel output is undetermined <sup>(3)</sup> . When $V_{CCO}$ transitions from unpowered to powered-up, a channel output assumes the selected default option.
X	X	X	Open	Undetermined	When ENx is unconnected or open, the device output will be in an undetermined and unknown state. ENx must be connected high or low for the device to behave correctly.

(1)  $V_{CCI}$  = Input-side  $V_{CC}$ ;  $V_{CCO}$  = Output-side  $V_{CC}$ ; PU = Powered up ( $V_{CC} \geq 1.54$  V); PD = Powered down ( $V_{CC} \leq 1.54$ ); X = Irrelevant; H = High level; L = Low level ; Z = High Impedance

(2) A strongly driven input signal can weakly power the floating  $V_{CC}$  through an internal protection diode and cause undetermined output.

(3) The outputs are in undetermined state when  $1.54$  V <  $V_{CCI}$ ,  $V_{CCO}$  <  $1.54$  V.

**9.4.1 Device I/O Schematics**

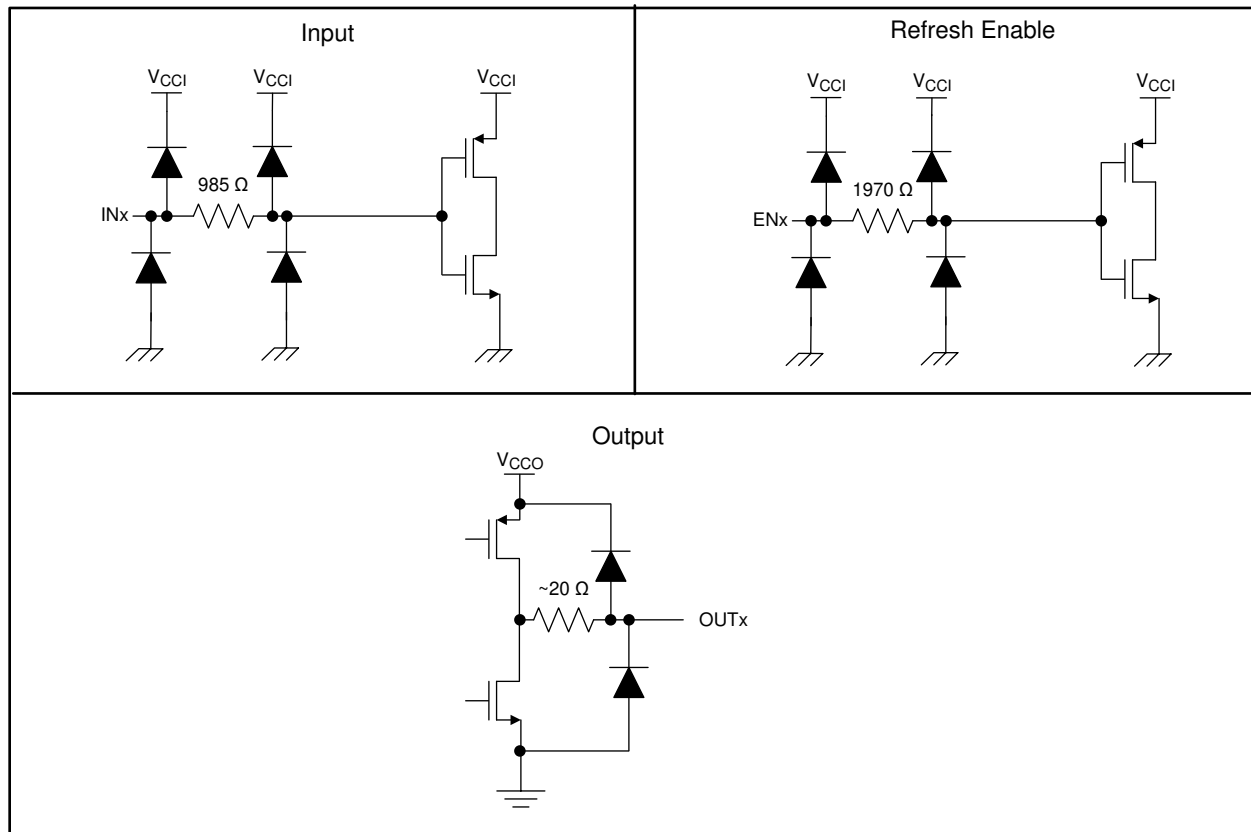

**Figure 15. Device I/O Schematics**



## 10 Application and Implementation

### NOTE

Information in the following applications sections is not part of the TI component specification, and TI does not warrant its accuracy or completeness. TI's customers are responsible for determining suitability of components for their purposes. Customers should validate and test their design implementation to confirm system functionality.

### 10.1 Application Information

The ISO7041 device is an ultra-low power digital isolator. The device uses single-ended CMOS-logic switching technology. The voltage range is from 1.71 V to 1.89 V and 2.25 V to 5.5 V for both supplies,  $V_{CC1}$  and  $V_{CC2}$ , and can be set irrespective of one another. When designing with digital isolators, keep in mind that because of the single-ended design structure, digital isolators do not conform to any specific interface standard and are only intended for isolating single-ended CMOS or TTL digital signal lines. The isolator is typically placed between the data controller (that is,  $\mu$ C or UART), and a data converter or a line transceiver, regardless of the interface type or standard. See [Isolated power and data interface for low-power applications reference design TI Design](#) for detailed information on designing the ISO70xx in low-power applications.

#### 10.1.1 Insulation Lifetime

Insulation lifetime projection data is collected by using industry-standard Time Dependent Dielectric Breakdown (TDDB) test method. In this test, all pins on each side of the barrier are tied together creating a two-terminal device and high voltage applied between the two sides; see [Figure 16](#) for TDDB test setup. The insulation breakdown data is collected at various high voltages switching at 60 Hz over temperature. For reinforced insulation, VDE standard requires the use of TDDB projection line with failure rate of less than 1 part per million (ppm) and a minimum insulation lifetime of 20 years. VDE standard also requires additional safety margin of 20% for working voltage and 87.5% for insulation lifetime which translates into minimum required life time of 37.5 years.

[Figure 17](#) shows the intrinsic capability of the isolation barrier to withstand high voltage stress over its lifetime. Based on the TDDB data, the intrinsic capability of these devices is 400 VRMS with a lifetime of >100 years. Other factors, such as package size, pollution degree, material group, and so forth can further limit the working voltage of the component. The working voltage of the DBQ-16 package specified up to 400 VRMS. At the lower working voltages, the corresponding insulation barrier life time is much longer.

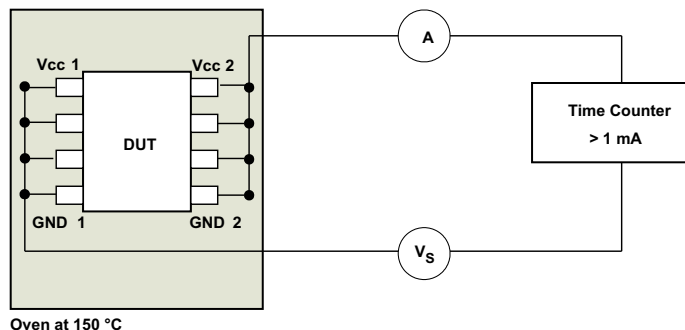
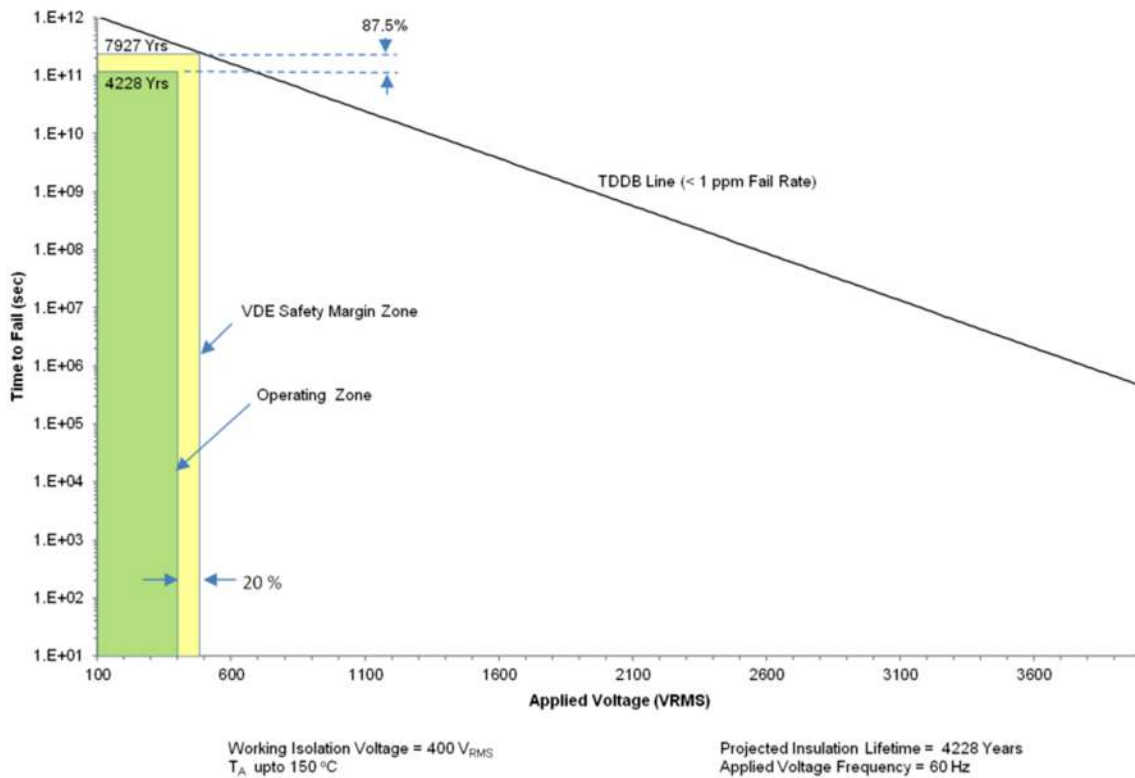

Figure 16. Test Setup for Insulation Lifetime Measurement

**Application Information (continued)**



**Figure 17. Insulation Lifetime Projection Data**

## Application Information (continued)

### 10.1.2 Intrinsic Safety

The ISO7041 supports Intrinsically Safe (IS) to IS applications and carry IECEx and ATEX certifications. These devices do not currently support IS to non-IS galvanic isolation applications due to the minimum insulation thickness requirements of IEC 60079-11.

#### 10.1.2.1 Schedule of Limitations

These components are certified to comply with IEC 60079-0, Edition 7, IEC 60079-11, Edition 6, EN 60079-0:2018 and EN 60070-11:2012. When one of these components is used in an equipment, the component is to be soldered on a PCB inside a suitable enclosure and re-evaluated as an equipment. The operating temperature range of these components is -55°C to +85°C. The creepage and clearance distances across the isolating component have been evaluated, but the distance to other circuitry remain the responsibility of the user of the final equipment.

This assembly is an isolating component between separate intrinsically safe circuits. The assembly must be connected to suitably certified intrinsically safe circuits considering the entity parameters and temperature ratings in the two different application scenarios shown in [Table 3](#).

**Table 3. Entity Parameters and Temperature Ratings**

APPLICATION	ENTITY PARAMETERS SIDE 1	ENTITY PARAMETERS SIDE 2	AMBIENT TEMPERATURE RANGE	MAXIMUM COMPONENT TEMPERATURE
IS to IS: Case 1	U <sub>i</sub> = 50 V	U <sub>i</sub> = 50 V	-55°C to +70°C	194.3°C
	I <sub>i</sub> = 300 mA	I <sub>i</sub> = 300 mA		
	P <sub>i</sub> = 1.3 W	P <sub>i</sub> = 1.3 W		
	L <sub>i</sub> = 0 H	L <sub>i</sub> = 0 H		
	C <sub>i</sub> = 4 pF	C <sub>i</sub> = 4 pF		
IS to IS: Case 2	U <sub>i</sub> = 50 V	U <sub>i</sub> = 50 V	-55°C to +85°C	183.1°C
	I <sub>i</sub> = 300 mA	I <sub>i</sub> = 300 mA		
	P <sub>i</sub> = 1.1 W	P <sub>i</sub> = 1.1 W		
	L <sub>i</sub> = 0 H	L <sub>i</sub> = 0 H		
	C <sub>i</sub> = 4 pF	C <sub>i</sub> = 4 pF		

## 10.2 Typical Application

Figure 18 shows the isolated serial peripheral interface (SPI).

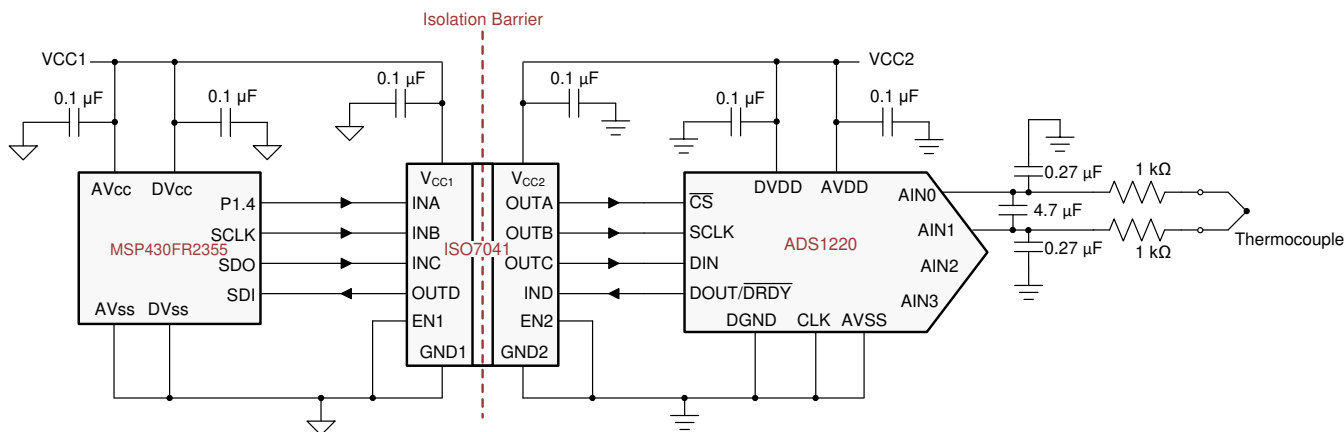

**Figure 18. Isolated SPI for a Temperature Field Transmitter**

## Typical Application (continued)

### 10.2.1 Design Requirements

To design with these devices, use the parameters listed in [Table 4](#).

**Table 4. Design Parameters**

PARAMETER	VALUE
Supply voltage, $V_{CC1}$ and $V_{CC2}$	1.71 V to 1.89 V or 2.25 V to 5.5 V
Decoupling capacitor between $V_{CC1}$ and GND1	0.1 $\mu$ F
Decoupling capacitor from $V_{CC2}$ and GND2	0.1 $\mu$ F

### 10.2.2 Detailed Design Procedure

Unlike optocouplers, which require external components to improve performance, provide bias, or limit current, the device only require two external bypass capacitors to operate.

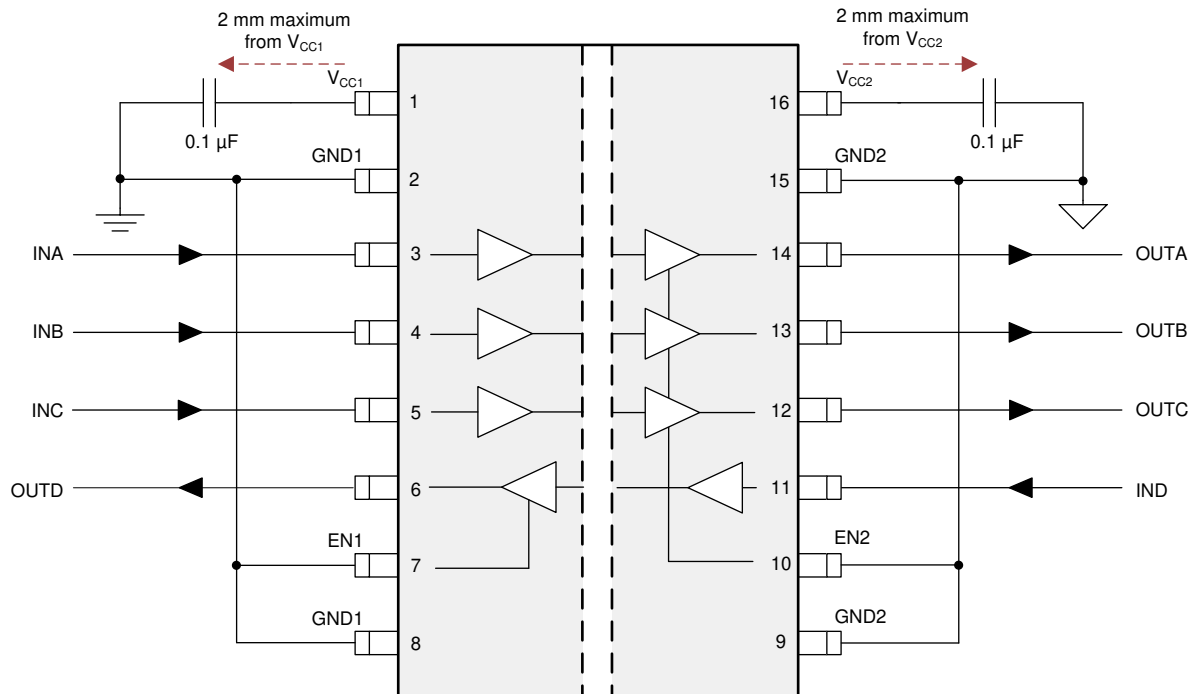

**Figure 19. Typical ISO7041 Circuit Hook-up**

### 10.2.3 Application Curves

The following typical eye diagrams of the device indicates wide open eye at the maximum data rate of 4 Mbps.



Figure 20. Eye Diagram at 4 Mbps PRBS  $2^{16} - 1$ , 1.8 V and 25°C



Figure 21. Eye Diagram at 4 Mbps PRBS  $2^{16} - 1$ , 2.5 V and 25°C

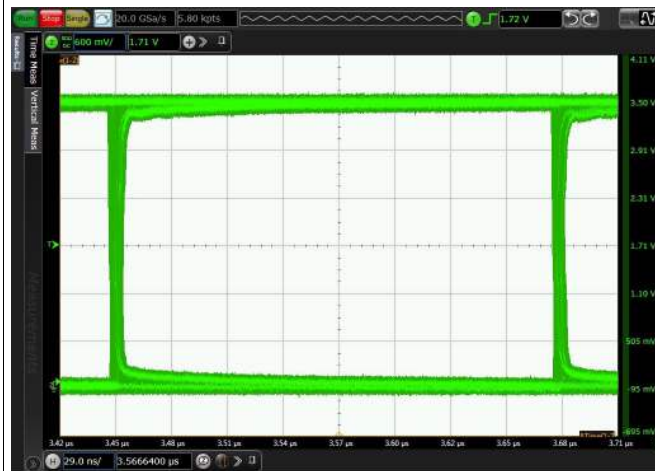

Figure 22. Eye Diagram at 4 Mbps PRBS  $2^{16} - 1$ , 3.3 V and 25°C

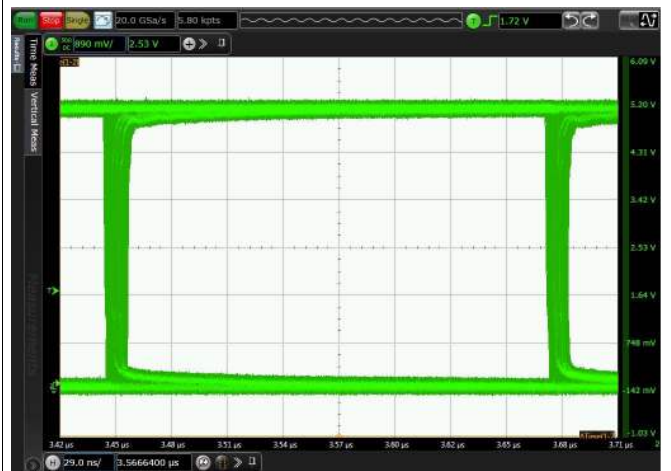

Figure 23. Eye Diagram at 4 Mbps PRBS  $2^{16} - 1$ , 5 V and 25°C

## 11 Power Supply Recommendations

Put a 0.1- $\mu$ F bypass capacitor at the input and output supply pins ( $V_{CC1}$  and  $V_{CC2}$ ) to make sure that operation is reliable at data rates and supply voltage. Put the capacitors as near to the supply pins as possible. If only one primary-side power supply is available in an application, use a transformer driver to help generate the isolated power for the secondary-side. Texas Instruments recommends the [SN6501](#) device or [SN6505A](#) device. Refer to the [SN6501 Transformer Driver for Isolated Power Supplies data sheet](#) or [SN6505 Low-Noise 1-A Transformer Drivers for Isolated Power Supplies data sheet](#) for detailed power supply design and transformer selection recommendations.

## 12 Layout

### 12.1 Layout Guidelines

A minimum of four layers is required to accomplish a low EMI PCB design (see [Figure 24](#)). Layer stacking should be in the following order (top-to-bottom): high-speed signal layer, ground plane, power plane and low-frequency signal layer.

- Routing the high-speed traces on the top layer avoids the use of vias (and the introduction of their inductances) and allows for clean interconnects between the isolator and the transmitter and receiver circuits of the data link.
- Placing a solid ground plane next to the high-speed signal layer establishes controlled impedance for transmission line interconnects and provides an excellent low-inductance path for the return current flow.
- Placing the power plane next to the ground plane creates additional high-frequency bypass capacitance of approximately 100 pF/in<sup>2</sup>.
- Routing the slower speed control signals on the bottom layer allows for greater flexibility as these signal links usually have margin to tolerate discontinuities such as vias.

If an additional supply voltage plane or signal layer is needed, add a second power or ground plane system to the stack to keep it symmetrical. This makes the stack mechanically stable and prevents it from warping. Also the power and ground plane of each power system can be placed closer together, thus increasing the high-frequency bypass capacitance significantly.

Refer to the [Digital Isolator Design Guide](#) for detailed layout recommendations,.

#### 12.1.1 PCB Material

For digital circuit boards operating at less than 150 Mbps, (or rise and fall times greater than 1 ns), and trace lengths of up to 10 inches, use standard FR-4 UL94V-0 printed circuit board. This PCB is preferred over cheaper alternatives because of lower dielectric losses at high frequencies, less moisture absorption, greater strength and stiffness, and the self-extinguishing flammability-characteristics.

### 12.2 Layout Example

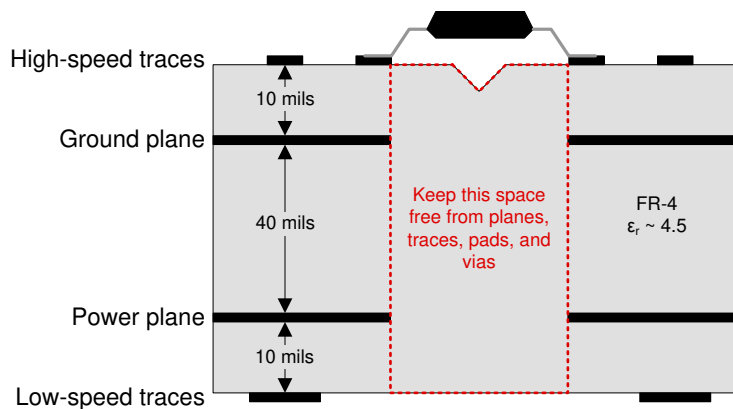

**Figure 24. Recommended Layer Stack**

## 13 Device and Documentation Support

### 13.1 Documentation Support

#### 13.1.1 Related Documentation

For related documentation see the following:

- Texas Instruments, [Digital Isolator Design Guide](#)
- Texas Instruments, [Isolation Glossary](#)
- Texas Instruments, [ADS1220 4-Channel, 2-kSPS, Low-Power, 24-Bit ADC with Integrated PGA and Reference data sheet](#)
- Texas Instruments, [ADS122U04 24-Bit, 4-Channel, 2-kSPS, Delta-Sigma ADC With UART Interface data sheet](#)
- Texas Instruments, [ADS124S0x Low-Power, Low-Noise, Highly Integrated, 6- and 12-Channel, 4-kSPS, 24-Bit, Delta-Sigma ADC with PGA and Voltage Reference data sheet](#)
- Texas Instruments, [Uniquely Efficient Isolated DC/DC Converter for Ultra-Low Power and Low-Power Applications TI Design](#)
- Texas Instruments, [SN6501 Transformer Driver for Isolated Power Supplies data sheet](#)
- Texas Instruments, [SN6505A Low-Noise 1-A Transformer Drivers for Isolated Power Supplies data sheet](#)
- Texas Instruments, [Isolated power and data interface for low-power applications reference design TI Design](#)

### 13.2 Receiving Notification of Documentation Updates

To receive notification of documentation updates, navigate to the device product folder on [ti.com](http://ti.com). In the upper right corner, click on *Alert me* to register and receive a weekly digest of any product information that has changed. For change details, review the revision history included in any revised document.

### 13.3 Community Resource

[TI E2E™ support forums](#) are an engineer's go-to source for fast, verified answers and design help — straight from the experts. Search existing answers or ask your own question to get the quick design help you need.

Linked content is provided "AS IS" by the respective contributors. They do not constitute TI specifications and do not necessarily reflect TI's views; see TI's [Terms of Use](#).

### 13.4 Trademarks

E2E is a trademark of Texas Instruments.

### 13.5 Electrostatic Discharge Caution



This integrated circuit can be damaged by ESD. Texas Instruments recommends that all integrated circuits be handled with appropriate precautions. Failure to observe proper handling and installation procedures can cause damage.

ESD damage can range from subtle performance degradation to complete device failure. Precision integrated circuits may be more susceptible to damage because very small parametric changes could cause the device not to meet its published specifications.

### 13.6 Glossary

[SLYZ022](#) — *TI Glossary*.

This glossary lists and explains terms, acronyms, and definitions.

## 14 Mechanical, Packaging, and Orderable Information

The following pages include mechanical packaging and orderable information. This information is the most current data available for the designated devices. This data is subject to change without notice and revision of this document. For browser-based versions of this data sheet, refer to the left-hand navigation.

**PACKAGING INFORMATION**

Orderable Device	Status (1)	Package Type	Package Drawing	Pins	Package Qty	Eco Plan (2)	Lead finish/ Ball material (6)	MSL Peak Temp (3)	Op Temp (°C)	Device Marking (4/5)	Samples
ISO7041DBQ	ACTIVE	SSOP	DBQ	16	75	RoHS & Green	NIPDAU	Level-2-260C-1 YEAR	-55 to 125	7041	<a href="#">Samples</a>
ISO7041DBQR	ACTIVE	SSOP	DBQ	16	2500	RoHS & Green	NIPDAU	Level-2-260C-1 YEAR	-55 to 125	7041	<a href="#">Samples</a>
ISO7041FDBQ	ACTIVE	SSOP	DBQ	16	75	RoHS & Green	NIPDAU	Level-2-260C-1 YEAR	-55 to 125	7041F	<a href="#">Samples</a>
ISO7041FDBQR	ACTIVE	SSOP	DBQ	16	2500	RoHS & Green	NIPDAU	Level-2-260C-1 YEAR	-55 to 125	7041F	<a href="#">Samples</a>

(1) The marketing status values are defined as follows:

**ACTIVE:** Product device recommended for new designs.

**LIFEBUY:** TI has announced that the device will be discontinued, and a lifetime-buy period is in effect.

**NRND:** Not recommended for new designs. Device is in production to support existing customers, but TI does not recommend using this part in a new design.

**PREVIEW:** Device has been announced but is not in production. Samples may or may not be available.

**OBSOLETE:** TI has discontinued the production of the device.

(2) **RoHS:** TI defines "RoHS" to mean semiconductor products that are compliant with the current EU RoHS requirements for all 10 RoHS substances, including the requirement that RoHS substance do not exceed 0.1% by weight in homogeneous materials. Where designed to be soldered at high temperatures, "RoHS" products are suitable for use in specified lead-free processes. TI may reference these types of products as "Pb-Free".

**RoHS Exempt:** TI defines "RoHS Exempt" to mean products that contain lead but are compliant with EU RoHS pursuant to a specific EU RoHS exemption.

**Green:** TI defines "Green" to mean the content of Chlorine (Cl) and Bromine (Br) based flame retardants meet JS709B low halogen requirements of <=1000ppm threshold. Antimony trioxide based flame retardants must also meet the <=1000ppm threshold requirement.

(3) **MSL, Peak Temp.** - The Moisture Sensitivity Level rating according to the JEDEC industry standard classifications, and peak solder temperature.

(4) There may be additional marking, which relates to the logo, the lot trace code information, or the environmental category on the device.

(5) Multiple Device Markings will be inside parentheses. Only one Device Marking contained in parentheses and separated by a "-" will appear on a device. If a line is indented then it is a continuation of the previous line and the two combined represent the entire Device Marking for that device.

(6) **Lead finish/Ball material** - Orderable Devices may have multiple material finish options. Finish options are separated by a vertical ruled line. Lead finish/Ball material values may wrap to two lines if the finish value exceeds the maximum column width.

**Important Information and Disclaimer:** The information provided on this page represents TI's knowledge and belief as of the date that it is provided. TI bases its knowledge and belief on information provided by third parties, and makes no representation or warranty as to the accuracy of such information. Efforts are underway to better integrate information from third parties. TI has taken and



continues to take reasonable steps to provide representative and accurate information but may not have conducted destructive testing or chemical analysis on incoming materials and chemicals. TI and TI suppliers consider certain information to be proprietary, and thus CAS numbers and other limited information may not be available for release.

In no event shall TI's liability arising out of such information exceed the total purchase price of the TI part(s) at issue in this document sold by TI to Customer on an annual basis.

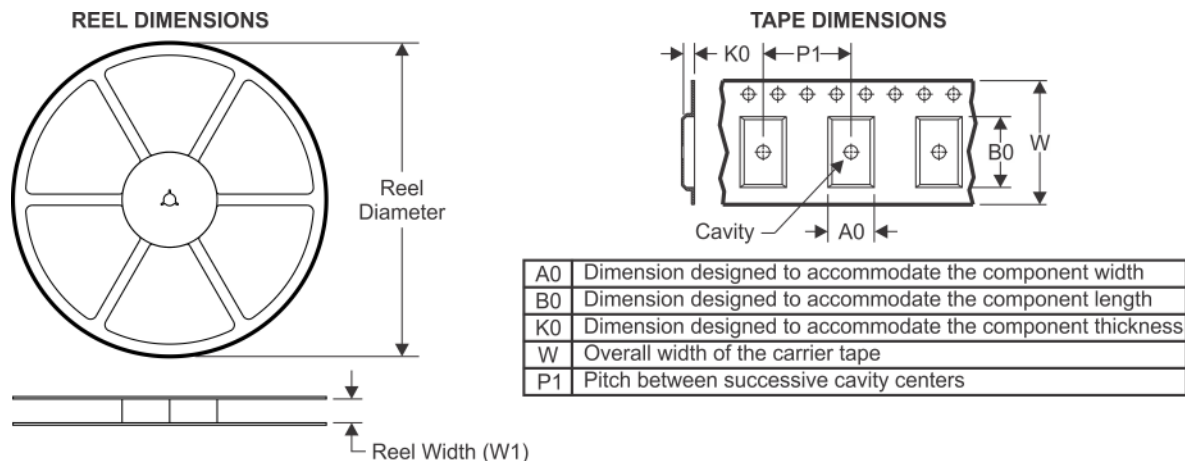
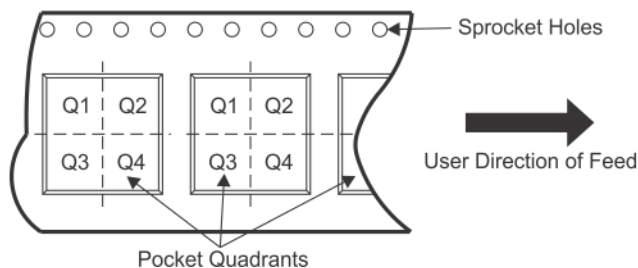
**TAPE AND REEL INFORMATION**

**QUADRANT ASSIGNMENTS FOR PIN 1 ORIENTATION IN TAPE**

\*All dimensions are nominal

Device	Package Type	Package Drawing	Pins	SPQ	Reel Diameter (mm)	Reel Width W1 (mm)	A0 (mm)	B0 (mm)	K0 (mm)	P1 (mm)	W (mm)	Pin1 Quadrant
ISO7041DBQR	SSOP	DBQ	16	2500	330.0	12.4	6.4	5.2	2.1	8.0	12.0	Q1
ISO7041FDBQR	SSOP	DBQ	16	2500	330.0	12.4	6.4	5.2	2.1	8.0	12.0	Q1

**TAPE AND REEL BOX DIMENSIONS**

\*All dimensions are nominal

Device	Package Type	Package Drawing	Pins	SPQ	Length (mm)	Width (mm)	Height (mm)
ISO7041DBQR	SSOP	DBQ	16	2500	350.0	350.0	43.0
ISO7041FDBQR	SSOP	DBQ	16	2500	350.0	350.0	43.0

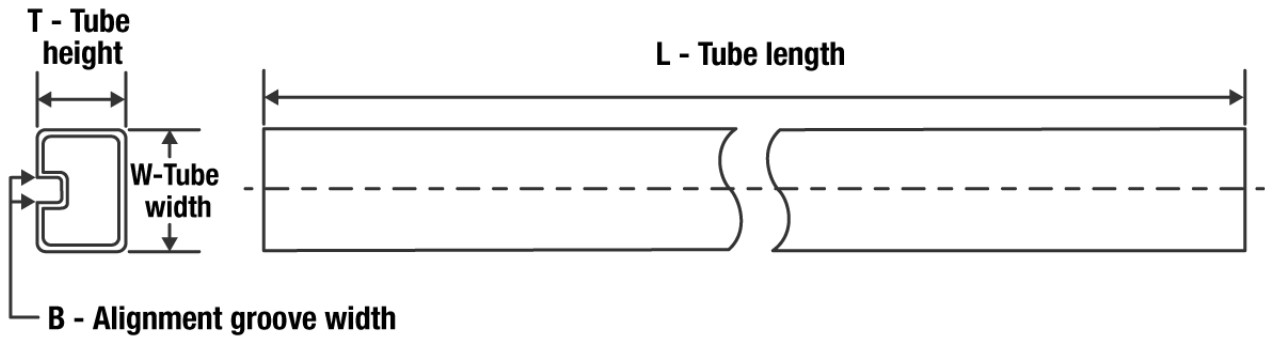
**TUBE**

\*All dimensions are nominal

Device	Package Name	Package Type	Pins	SPQ	L (mm)	W (mm)	T (μm)	B (mm)
ISO7041DBQ	DBQ	SSOP	16	75	505.46	6.76	3810	4
ISO7041FDBQ	DBQ	SSOP	16	75	505.46	6.76	3810	4



# PACKAGE OUTLINE

## DBQ0016A

### SSOP - 1.75 mm max height

SHRINK SMALL-OUTLINE PACKAGE

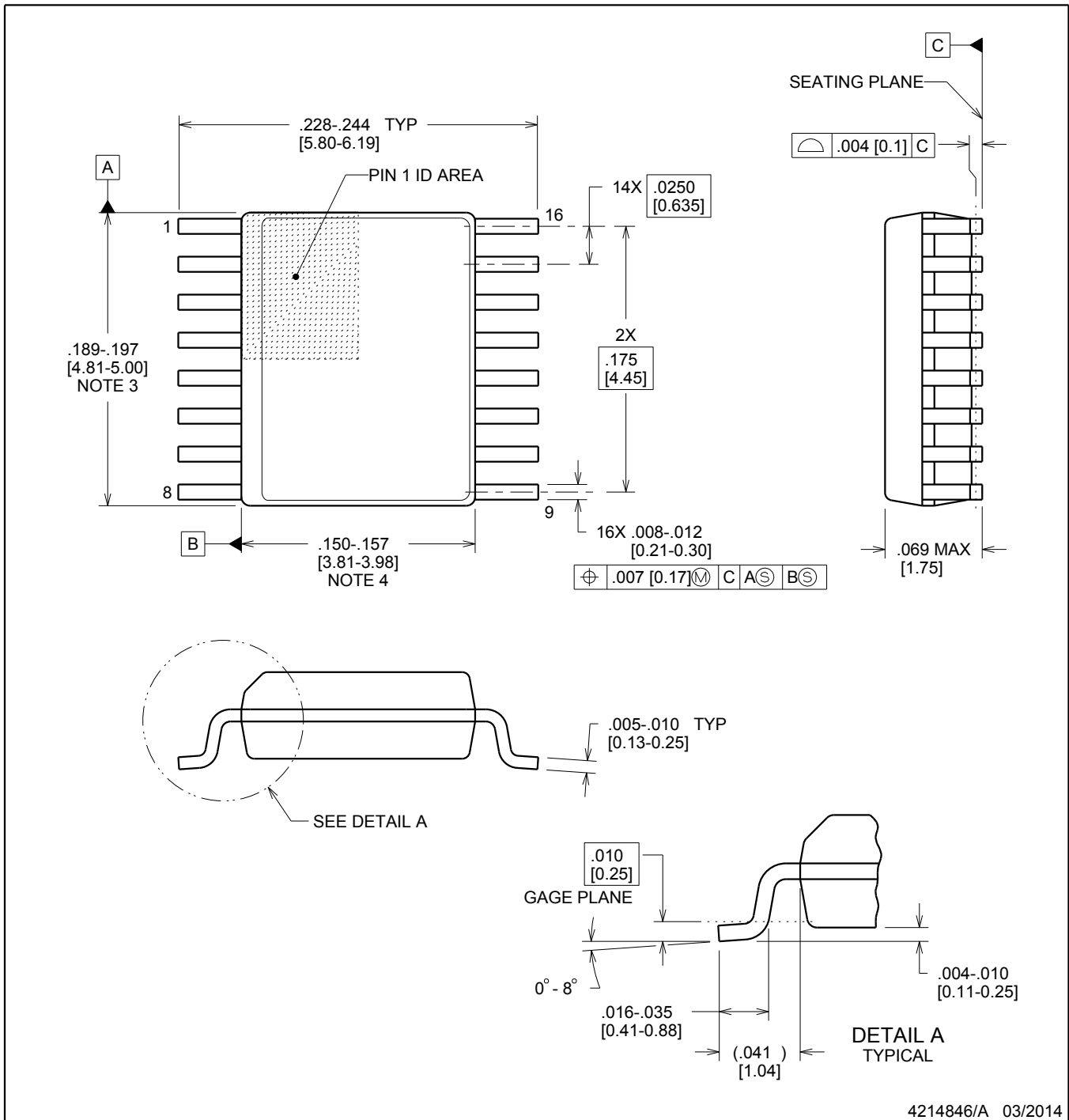

#### NOTES:

1. Linear dimensions are in inches [millimeters]. Dimensions in parenthesis are for reference only. Controlling dimensions are in inches. Dimensioning and tolerancing per ASME Y14.5M.
2. This drawing is subject to change without notice.
3. This dimension does not include mold flash, protrusions, or gate burrs. Mold flash, protrusions, or gate burrs shall not exceed .006 inch, per side.
4. This dimension does not include interlead flash.
5. Reference JEDEC registration MO-137, variation AB.

# EXAMPLE BOARD LAYOUT

DBQ0016A

SSOP - 1.75 mm max height

SHRINK SMALL-OUTLINE PACKAGE

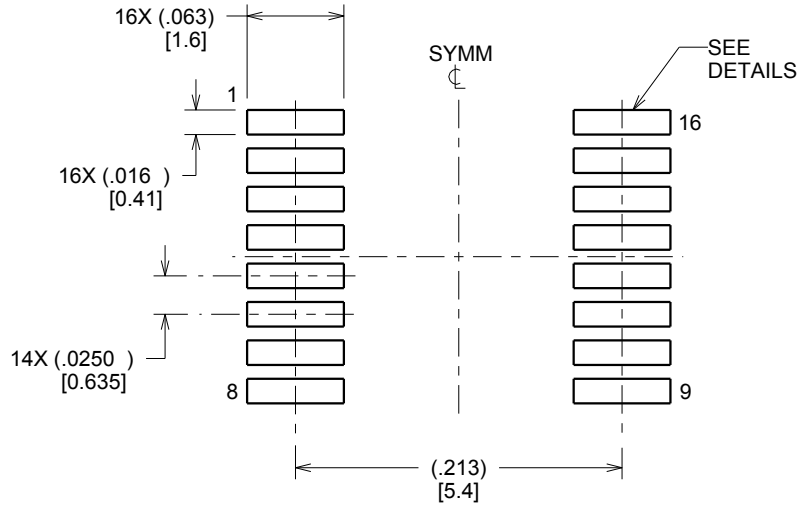

LAND PATTERN EXAMPLE  
SCALE:8X

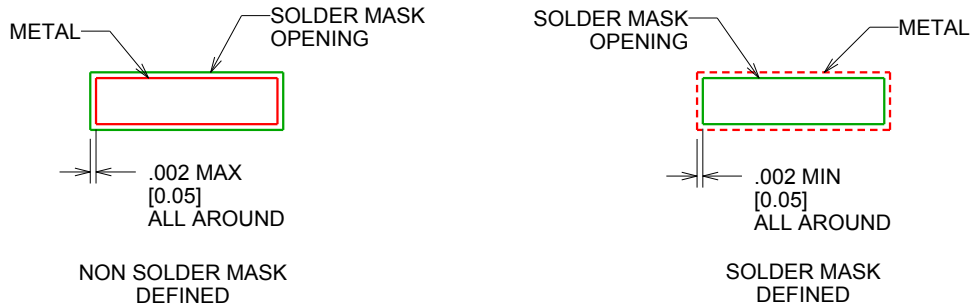

SOLDER MASK DETAILS

4214846/A 03/2014

NOTES: (continued)

6. Publication IPC-7351 may have alternate designs.

7. Solder mask tolerances between and around signal pads can vary based on board fabrication site.

# EXAMPLE STENCIL DESIGN

DBQ0016A

SSOP - 1.75 mm max height

SHRINK SMALL-OUTLINE PACKAGE

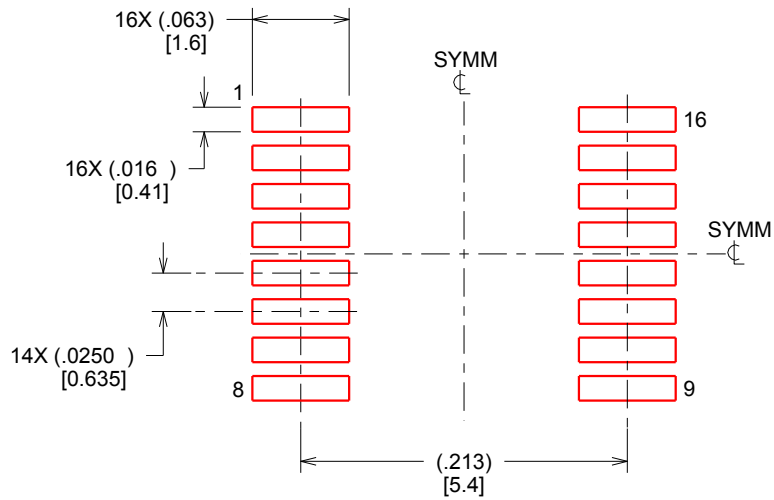

SOLDER PASTE EXAMPLE  
BASED ON .005 INCH [0.127 MM] THICK STENCIL  
SCALE:8X

4214846/A 03/2014

NOTES: (continued)

8. Laser cutting apertures with trapezoidal walls and rounded corners may offer better paste release. IPC-7525 may have alternate design recommendations.
9. Board assembly site may have different recommendations for stencil design.

## IMPORTANT NOTICE AND DISCLAIMER

TI PROVIDES TECHNICAL AND RELIABILITY DATA (INCLUDING DATA SHEETS), DESIGN RESOURCES (INCLUDING REFERENCE DESIGNS), APPLICATION OR OTHER DESIGN ADVICE, WEB TOOLS, SAFETY INFORMATION, AND OTHER RESOURCES "AS IS" AND WITH ALL FAULTS, AND DISCLAIMS ALL WARRANTIES, EXPRESS AND IMPLIED, INCLUDING WITHOUT LIMITATION ANY IMPLIED WARRANTIES OF MERCHANTABILITY, FITNESS FOR A PARTICULAR PURPOSE OR NON-INFRINGEMENT OF THIRD PARTY INTELLECTUAL PROPERTY RIGHTS.

These resources are intended for skilled developers designing with TI products. You are solely responsible for (1) selecting the appropriate TI products for your application, (2) designing, validating and testing your application, and (3) ensuring your application meets applicable standards, and any other safety, security, regulatory or other requirements.

These resources are subject to change without notice. TI grants you permission to use these resources only for development of an application that uses the TI products described in the resource. Other reproduction and display of these resources is prohibited. No license is granted to any other TI intellectual property right or to any third party intellectual property right. TI disclaims responsibility for, and you will fully indemnify TI and its representatives against, any claims, damages, costs, losses, and liabilities arising out of your use of these resources.

TI's products are provided subject to [TI's Terms of Sale](#) or other applicable terms available either on [ti.com](http://ti.com) or provided in conjunction with such TI products. TI's provision of these resources does not expand or otherwise alter TI's applicable warranties or warranty disclaimers for TI products.

TI objects to and rejects any additional or different terms you may have proposed.

Mailing Address: Texas Instruments, Post Office Box 655303, Dallas, Texas 75265  
Copyright © 2022, Texas Instruments Incorporated