

THIS DRAWING IS UNPUBLISHED. RELEASED FOR PUBLICATION
 © COPYRIGHT - TE Connectivity Ltd. ALL RIGHTS RESERVED.

REVISIONS					
P	LTR	DESCRIPTION	DATE	DWN	APVD
	B2	REVISED PER ECR-18-018655	17DEC2018	BW	SV

IDENTIFICATION NUMBER 24 FOR MAGNET WIRE RANGE

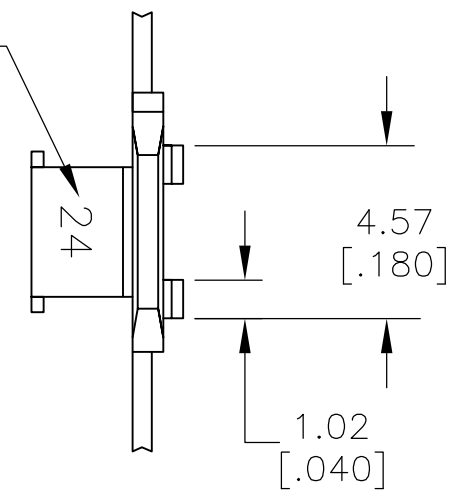

- 1 CONTINUOUS STRIP ON REELS WITH TERMINALS LOCATED ON 8.38 [.330] CENTERS.
- 2 SLOT TERMINATES SINGLE COPPER MAGNET WIRE WIRE RANGE: 0.91-1.15mm [#19-#17] AWG ALUMINUM WIRE RANGE: 0.95-1.15mm [#18.5-#17] AWG. ALUMINUM WIRE RANGE APPLIES FOR POST-TIN PLATED VERSIONS ONLY.

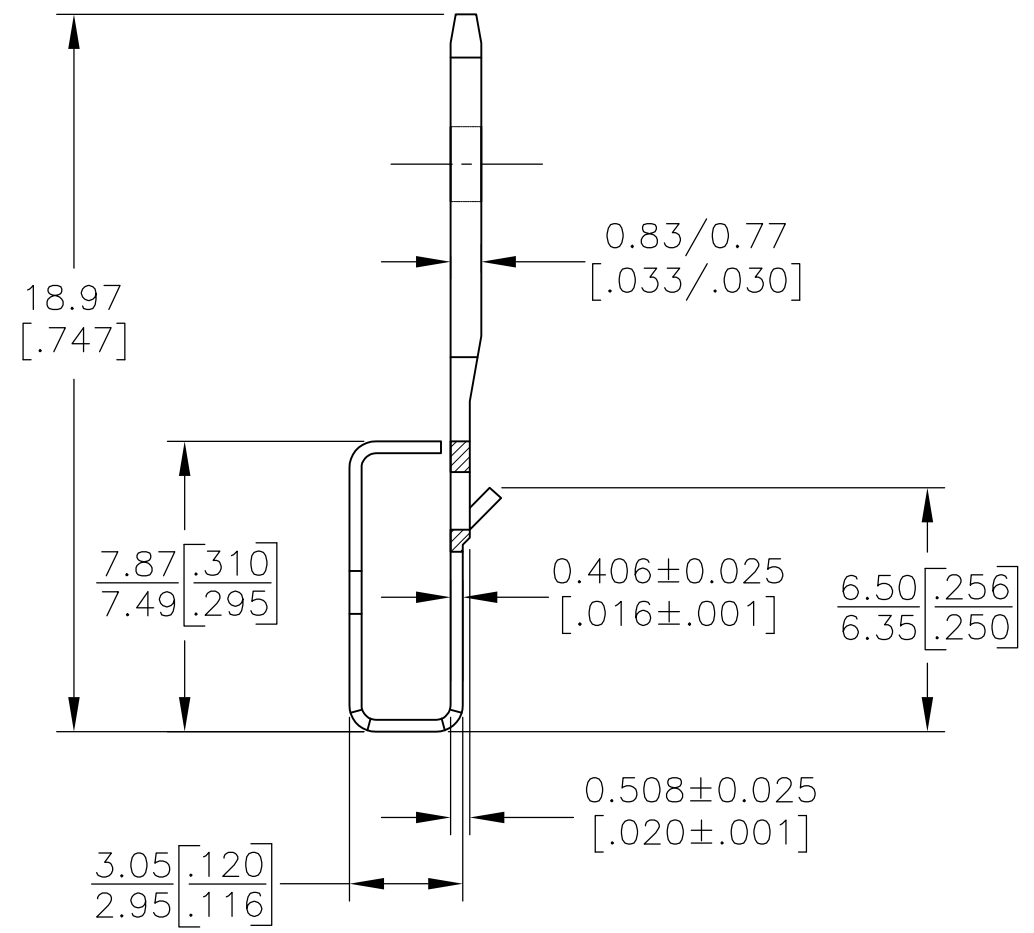
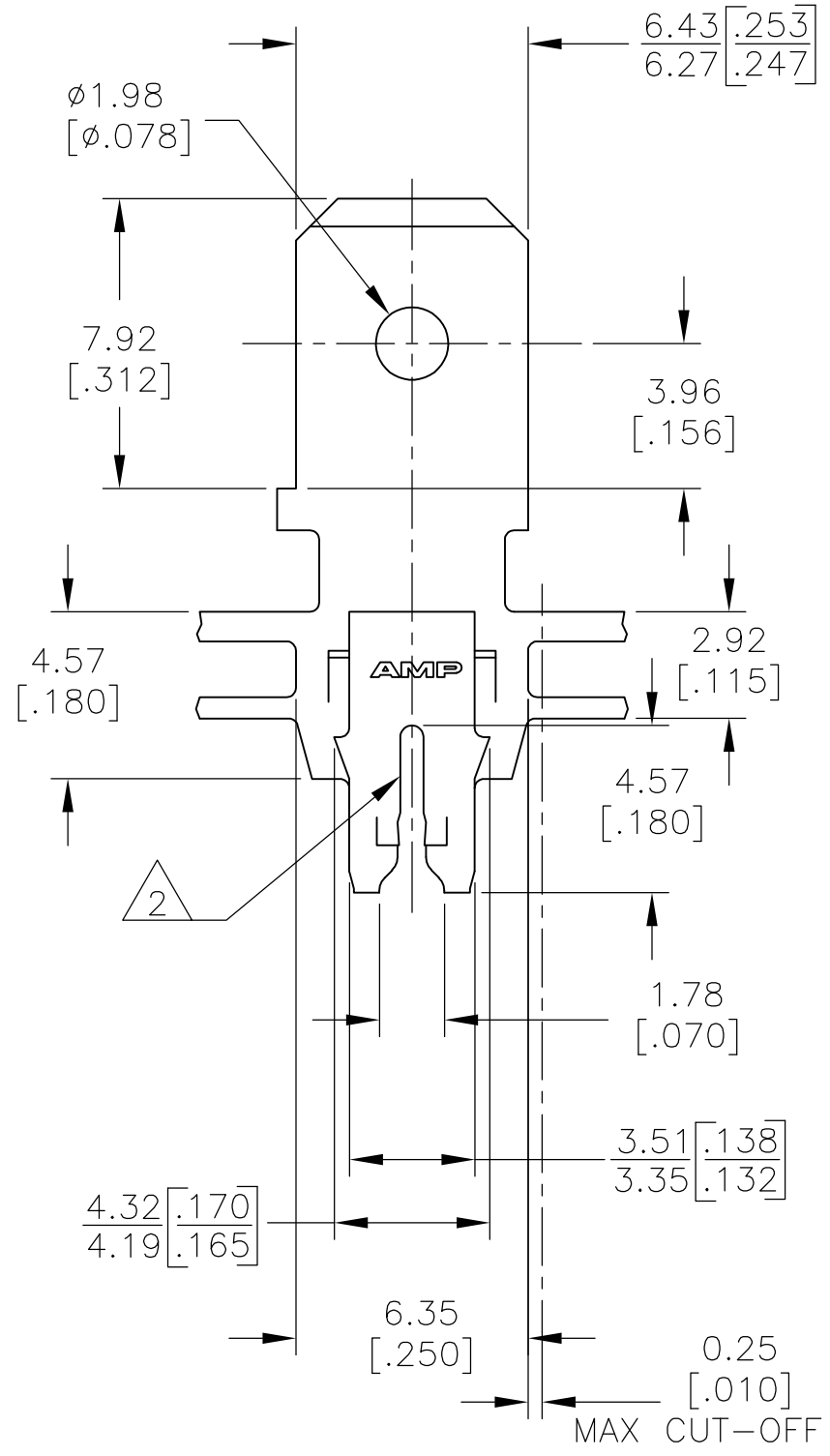

63614-1
PART NUMBER

THIS DRAWING IS A CONTROLLED DOCUMENT.		DWN MICHAEL S. FEHER 5/9/91	TE Connectivity Ltd.			
DIMENSIONS: mm [INCHES]		CHK JEFF R. RUTH 5/13/91				
TOLERANCES UNLESS OTHERWISE SPECIFIED:		APVD NELSON E. NEFF 5/13/91	NAME TAB, 6.35 [.250] FASTON,™ MAG-MATE™			
0 PLC ± - 1 PLC ± - 2 PLC ± 0.25 [.010] 3 PLC ± - 4 PLC ± - ANGLES ± -		PRODUCT SPEC 108-2012	RESTRICTED TO			
MATERIAL #4M HARD PRE-MILLED BRASS		FINISH 0.002032[.000080] MIN TIN PER MIL-T-10727	APPLICATION SPEC 114-2094	SIZE A3	CAGE CODE 00779	DRAWING NO G-63614
CUSTOMER DRAWING			WEIGHT -	SCALE 5:1	SHEET 1 OF 1	REV B2