

PROPRIETARY NOTE
 THIS DOCUMENT CONTAINS CONFIDENTIAL AND PROPRIETARY INFORMATION AND ALL DESIGN, MANUFACTURING, REPRODUCTION, USE, PATENT RIGHTS AND SALES RIGHTS ARE EXPRESSLY RESERVED BY SAMTEC, INC. THIS DOCUMENT SHALL NOT BE DISCLOSED, IN WHOLE OR PART, TO ANY UNAUTHORIZED PERSON OR ENTITY NOR REPRODUCED, TRANSFERRED OR INCORPORATED IN ANY OTHER PROJECT IN ANY MANNER WITHOUT THE EXPRESS WRITTEN CONSENT OF SAMTEC, INC.

DO NOT SCALE DRAWING
 SHEET SCALE: 1:0.666667



520 PARK EAST BLVD, NEW ALBANY, IN 47150
 PHONE: 812-944-6733 FAX: 812-948-5047
 e-Mail: info@SAMTEC.com code: 55322

DESCRIPTION:
 CABLE ASSEMBLY, IJ5C CONNECTOR

DWG. NO.
IJ5C-XX-XXXX-X-X-XXX-X-XX

BY: KNOWLDEN 04/16/2008 SHEET 2 OF 4

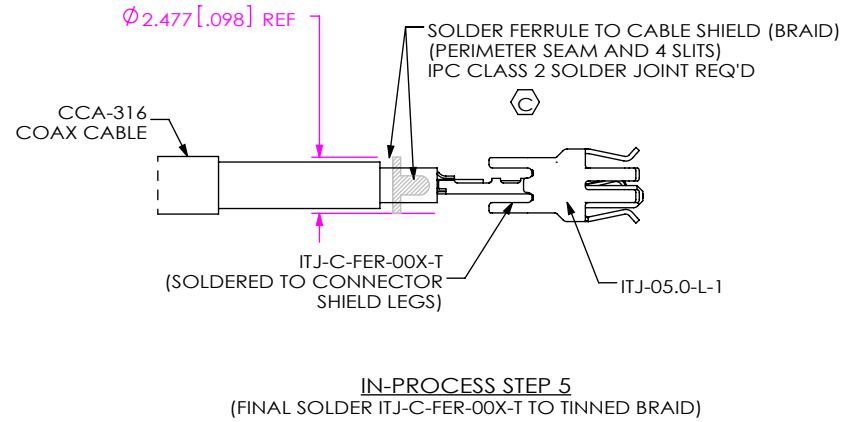
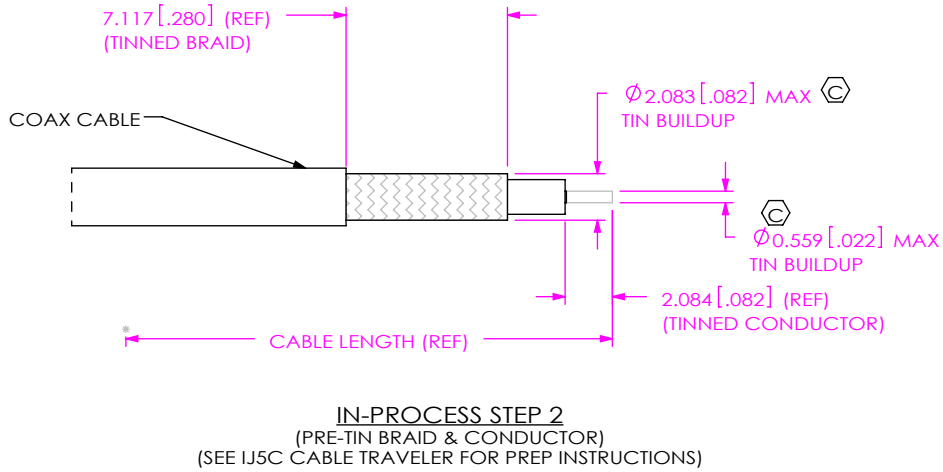
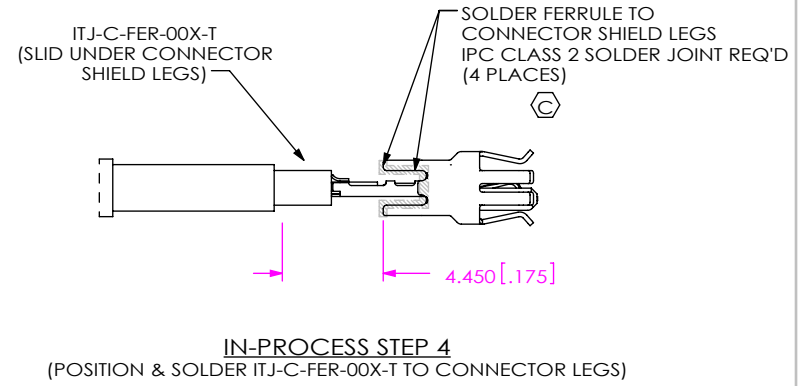
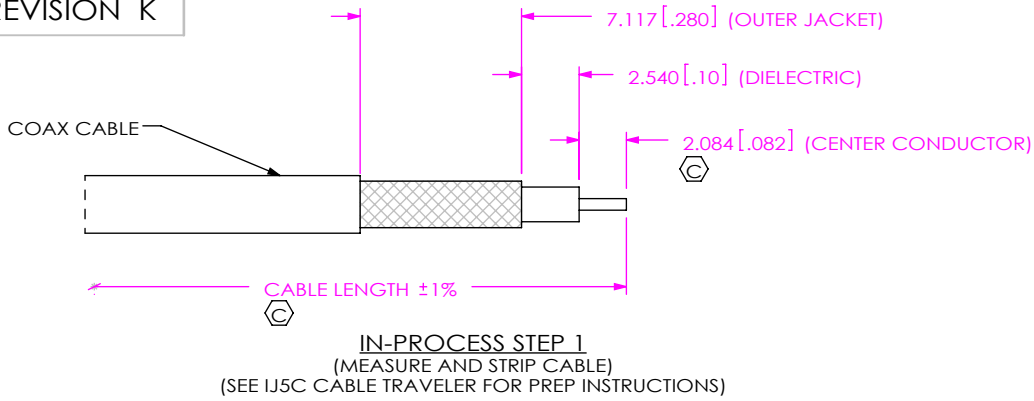

ORIENTING SUB-IJ5C-05.0-NXS-X

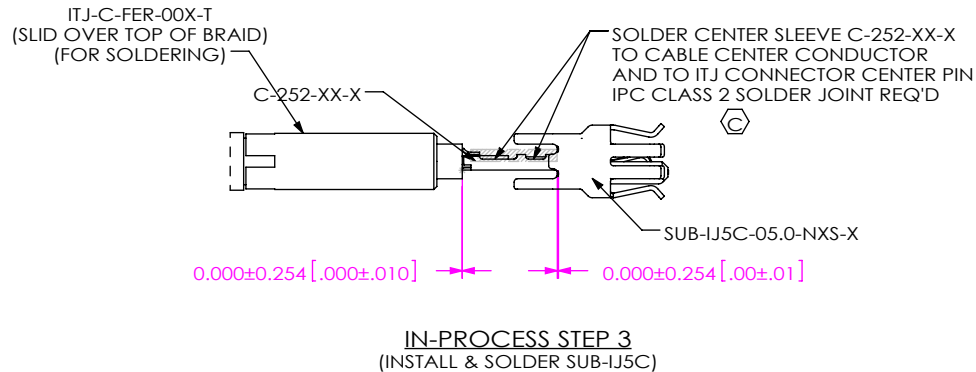

PROPRIETARY NOTE
THIS DOCUMENT CONTAINS CONFIDENTIAL AND PROPRIETARY INFORMATION AND ALL DESIGN, MANUFACTURING, REPRODUCTION, USE, PATENT RIGHTS AND SALES RIGHTS ARE EXPRESSLY RESERVED BY SAMTEC, INC. THIS DOCUMENT SHALL NOT BE DISCLOSED, IN WHOLE OR PART, TO ANY UNAUTHORIZED PERSON OR ENTITY NOR REPRODUCED, TRANSFERRED OR INCORPORATED IN ANY OTHER PROJECT IN ANY MANNER WITHOUT THE EXPRESS WRITTEN CONSENT OF SAMTEC, INC.

DO NOT SCALE DRAWING

SHEET SCALE: 1:1



520 PARK EAST BLVD, NEW ALBANY, IN 47150
PHONE: 812-944-6733 FAX: 812-948-5047
e-Mail: info@SAMTEC.com code: 55322

DESCRIPTION:
CABLE ASSEMBLY, IJ5C CONNECTOR
DWG. NO.
IJ5C-XX-XXXX-X-X-XXX-X-XX

BY: KNOWLDEN 04/16/2008 SHEET 3 OF 4

REVISION K

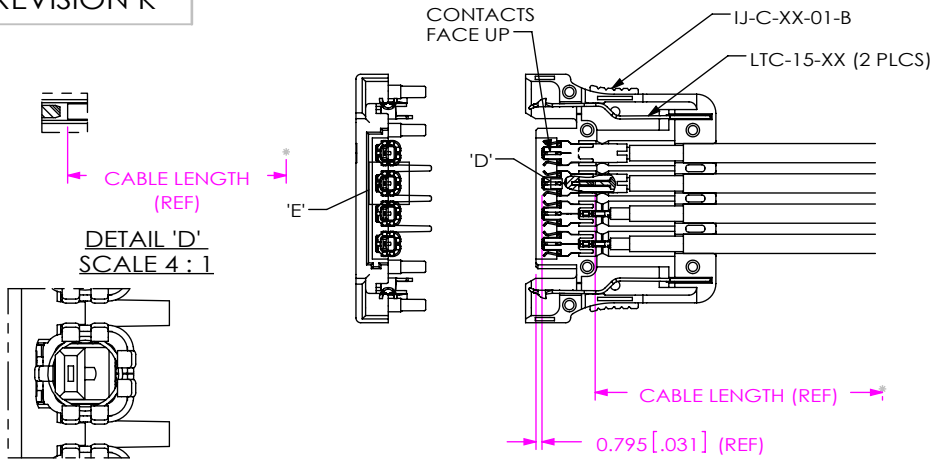

DETAIL 'E'
SCALE 4 : 1

IN-PROCESS STEP 6
(FILL BOTTOM COVER HOUSING)

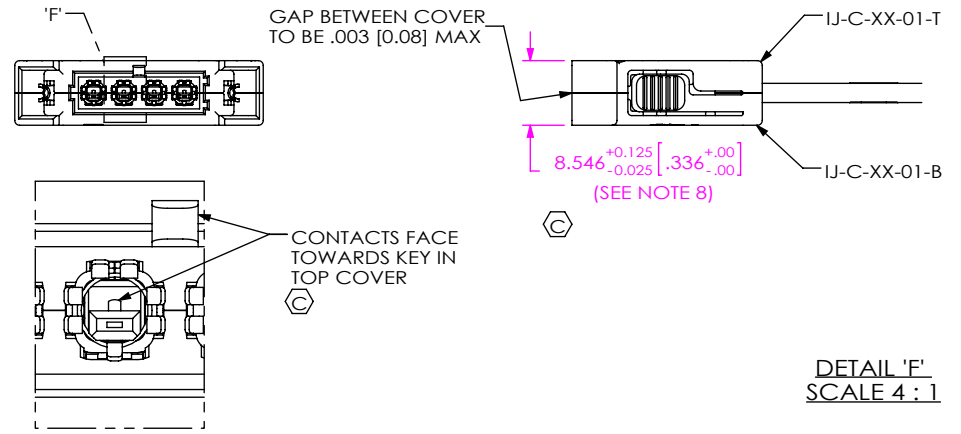

DETAIL 'F'
SCALE 4 : 1

IN-PROCESS STEP 8
(THERMO WELD COVERS)

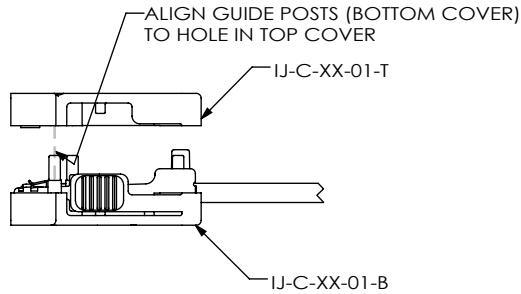

IN-PROCESS STEP 7
(ASSEMBLE TOP COVER HOUSING)

TABLE 2								
No. OF POS	END OPTION	CABLE TYPE		SUB	FERRULE	TOP HOUSING	BOTTOM HOUSING	LATCH
		OPTION	CABLE NAME					
-01	-S	-1	CTB-2650F-01	SUB-IJ5C-05.0-NXS-XXX	ITJ-C-FER-001-T	IJ-C-01-01-T	IJ-C-01-01-B	LTC-15-01
		-2	CCA-316		ITJ-C-FER-002-T			
	-D	-1	CTB-2650F-01		ITJ-C-FER-001-T			
		-2	CCA-316		ITJ-C-FER-002-T			
-02	-S	-1	CTB-2650F-01	SUB-IJ5C-05.0-NXS-XXX	ITJ-C-FER-001-T	IJ-C-02-01-T	IJ-C-02-01-B	LTC-15-01
		-2	CCA-316		ITJ-C-FER-002-T			
	-D	-1	CTB-2650F-01		ITJ-C-FER-001-T			
		-2	CCA-316		ITJ-C-FER-002-T			
-04	-S	-1	CTB-2650F-01	SUB-IJ5C-05.0-NXS-XXX	ITJ-C-FER-001-T	IJ-C-04-01-T	IJ-C-04-01-B	LTC-15-01
		-2	CCA-316		ITJ-C-FER-002-T			
	-D	-1	CTB-2650F-01		ITJ-C-FER-001-T			
		-2	CCA-316		ITJ-C-FER-002-T			
-06	-S	-1	CTB-2650F-01	SUB-IJ5C-05.0-NXS-XXX	ITJ-C-FER-001-T	IJ-C-06-01-T	IJ-C-06-01-B	LTC-15-01
		-2	CCA-316		ITJ-C-FER-002-T			
	-D	-1	CTB-2650F-01		ITJ-C-FER-001-T			
		-2	CCA-316		ITJ-C-FER-002-T			
-08	-S	-1	CTB-2650F-01	SUB-IJ5C-05.0-NXS-XXX	ITJ-C-FER-001-T	IJ-C-08-01-T	IJ-C-08-01-B	LTC-15-01
		-2	CCA-316		ITJ-C-FER-002-T			
	-D	-1	CTB-2650F-01		ITJ-C-FER-001-T			
		-2	CCA-316		ITJ-C-FER-002-T			

PROPRIETARY NOTE
 THIS DOCUMENT CONTAINS CONFIDENTIAL AND PROPRIETARY INFORMATION AND ALL DESIGN, MANUFACTURING, REPRODUCTION, USE, PATENT RIGHTS AND SALES RIGHTS ARE EXPRESSLY RESERVED BY SAMTEC, INC. THIS DOCUMENT SHALL NOT BE DISCLOSED, IN WHOLE OR PART, TO ANY UNAUTHORIZED PERSON OR ENTITY NOR REPRODUCED, TRANSFERRED OR INCORPORATED IN ANY OTHER PROJECT IN ANY MANNER WITHOUT THE EXPRESS WRITTEN CONSENT OF SAMTEC, INC.

DO NOT SCALE DRAWING
 SHEET SCALE: 1:1



520 PARK EAST BLVD, NEW ALBANY, IN 47150
 PHONE: 812-944-6733 FAX: 812-948-5047
 e-Mail: info@SAMTEC.com code: 55322

DESCRIPTION:
 CABLE ASSEMBLY, IJ5C CONNECTOR
 DWG. NO.
IJ5C-XX-XXXX-X-X-XXX-X-XX
 BY: KNOWLDEN 04/16/2008 SHEET 4 OF 4