

# Mateable transfer wiring-system

for connectors to DIN 41 612 and VG 95 324

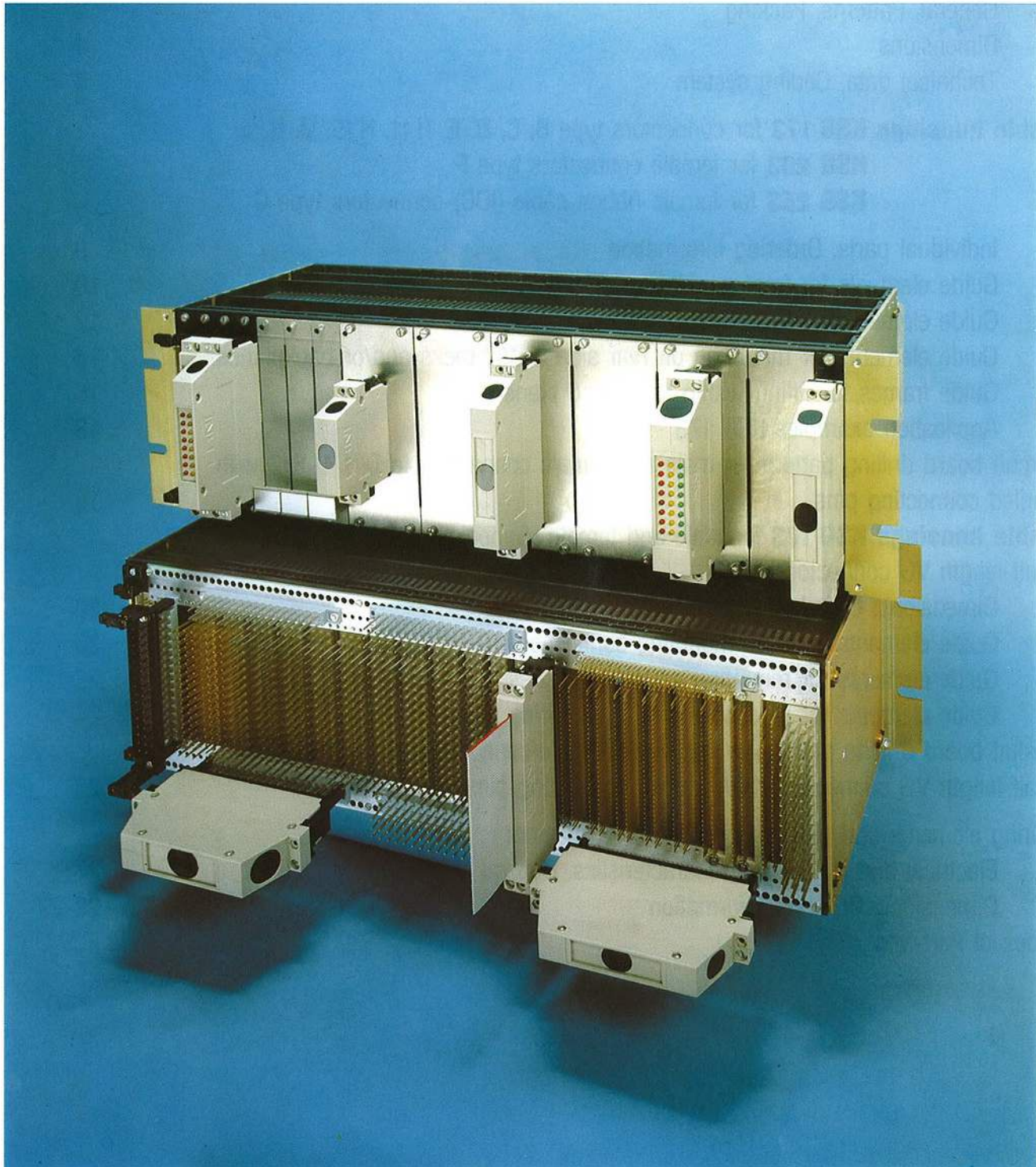

# ERNI

ERNI Elektroapparate GmbH  
D-73099 Adelberg

☎ ++49-7166-500 7 27 759

Telefax: ++49-7166-50 282

---

## Table of contents

Cable housings for connectors to DIN 41 612 and VG 95 324	
General, Patterns, Packing	3
Dimensions	4-7
Technical data, Coding system	8
<b>Cable housings KSG 173</b> for connectors type B, C, D, E, H11, H15, Q, R	
<b>KSG 203</b> for female connectors type F	
<b>KSG 253</b> for female ribbon-cable (IDC)-connectors type C	
Individual parts, Ordering information	9
Guide elements for front panel connection	10
Guide elements for mounting through wiring field	12
Guide elements for mounting on rear side of 19" racks and/or backplanes	14
Guide frames for fitting within the wiring plane	16
Application examples KSG 173	18
Circuit board drilling pattern for male and female connectors to DIN 41 612 with angled connecting pins	19
<b>Cable housings KSG 193</b> for male and female connectors types BK and CK (half-length VG connectors)	
Dimensions, Ordering information	20
Guide elements for front mounting connections	20
Guide elements for mounting on wiring planes	22
Guide elements for mounting within the wiring planes	24
Circuit board drilling pattern for male and female connectors to VG 95 324 (half-length VG connectors) with angled connecting pins	26
Wiring elements and plug-on distribution connectors	
Electrical and mechanical characteristics, General	27
Dimensions, Ordering information	28-29
Index of Part-Nos.	30

## Cable housings KSG 173, 203, 253, 193

for connectors DIN 41 612 and VG 95 324



### General:

This cable housing family meets the demand for a fully-insulated compact housing suitable for holding either the male or female half of connectors to DIN 41 612.

The mechanical protection provided by the cable housings makes these PCB-related connectors suitable for **all kind of electrical interfaces**. They can be used as board-to-wire connectors, as coding or test plugs or as plug-in jumper connections.

Suitable guide elements assist in matching the two connector halves and also offer coding possibilities.

**These universal cable housings have been developed in close cooperation with leading manufacturers of electronic equipment.**

### Patterns:

#### KSG 173

for male or female connectors types B, C, D, H 11, Q, R, housing width 15.24 mm (.6") (3T)

Female connectors type H 15 housing width 15.24 mm (.6") (3T)

for male and female connectors type E housing width 20.32 mm (.8") (4T)

#### KSG 203

for female connectors type F housing width 15.24 mm (.6") (3T)

#### KSG 253

for female ribbon-cable (IDC)-connectors type C housing width 15.24 mm (.6") (3T)

All housings in this family offer the following advantages.

- A strong, fully insulated housing;
- Exclusion of any mechanical stress on the multi-pin connectors during insertion, operation and withdrawal;
- Lifting screws (which can be turned successively) make it easy to overcome insertion and withdrawal forces;
- Suitable guide elements to facilitate mounting on the front panels or wiring ends of PCB modules;
- Suitable for providing signal or current interconnections between (19"-) racks;
- Three alternative cable outlet positions;
- Reliable strain-relief;
- Retrofitting of coding devices possible;
- Attractive design.

#### KSG 193

for male and female connectors types BK and CK housing width 15.24 mm (.6") (3T)

### Packing:

#### Cable housings

as component sets packed in bags - without guide elements

#### Guide elements

as component sets packed in bags including fastening elements

#### Coding

as component sets packed in bags including fastening elements

## Dimensions

### Cable housing KSG 173 for male and female connectors types B, C, D, H11, Q, R

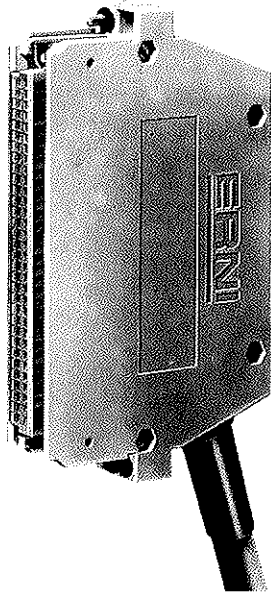

An adaptor element is necessary for fitting types B and Q.

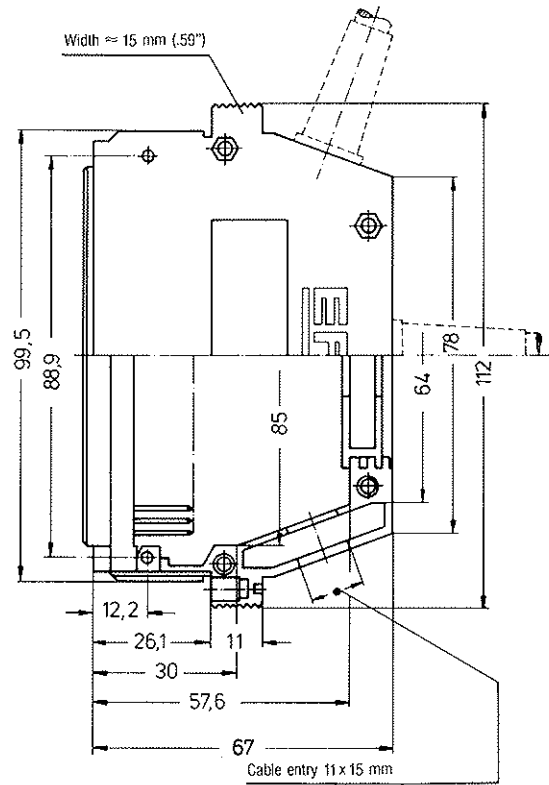

### Cable housing KSG 173 for male and female connectors type E

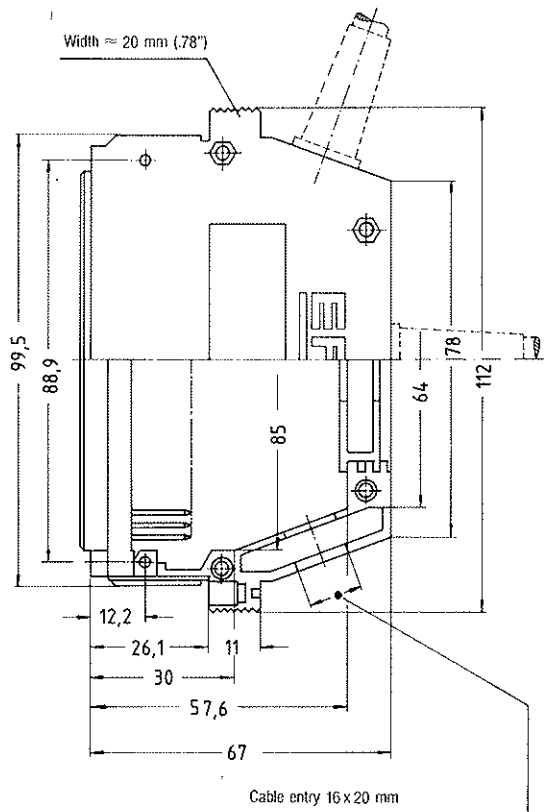
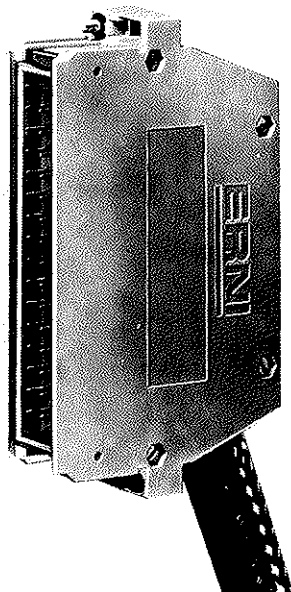

## Dimensions

### Cable housings KSG 173 for female connectors type H15

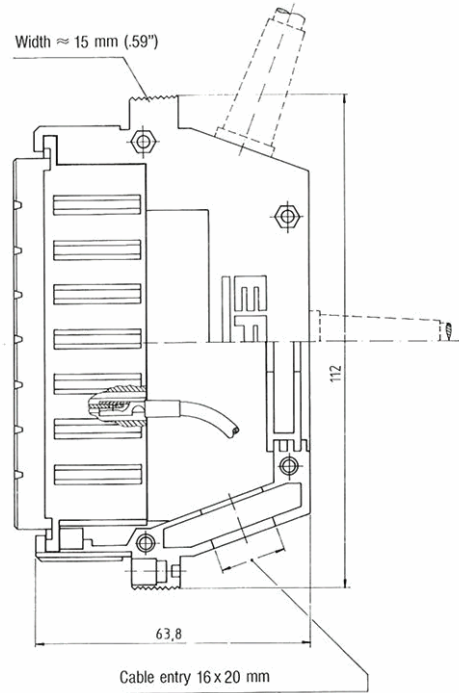
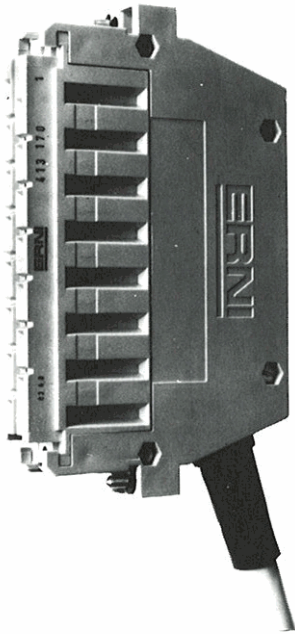

### Cable housings KSG 203 for female connectors type F

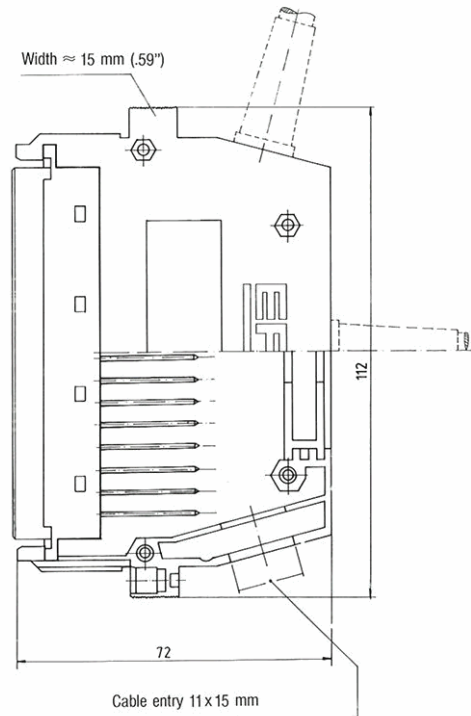
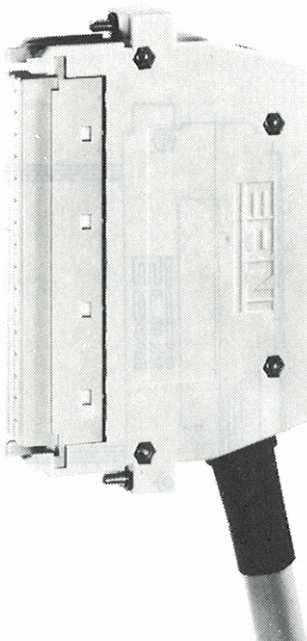

## Dimensions

### Cable housings KSG 253 for female ribbon-cable (IDC) – connectors type C

#### Cable entries at rear and on both sides

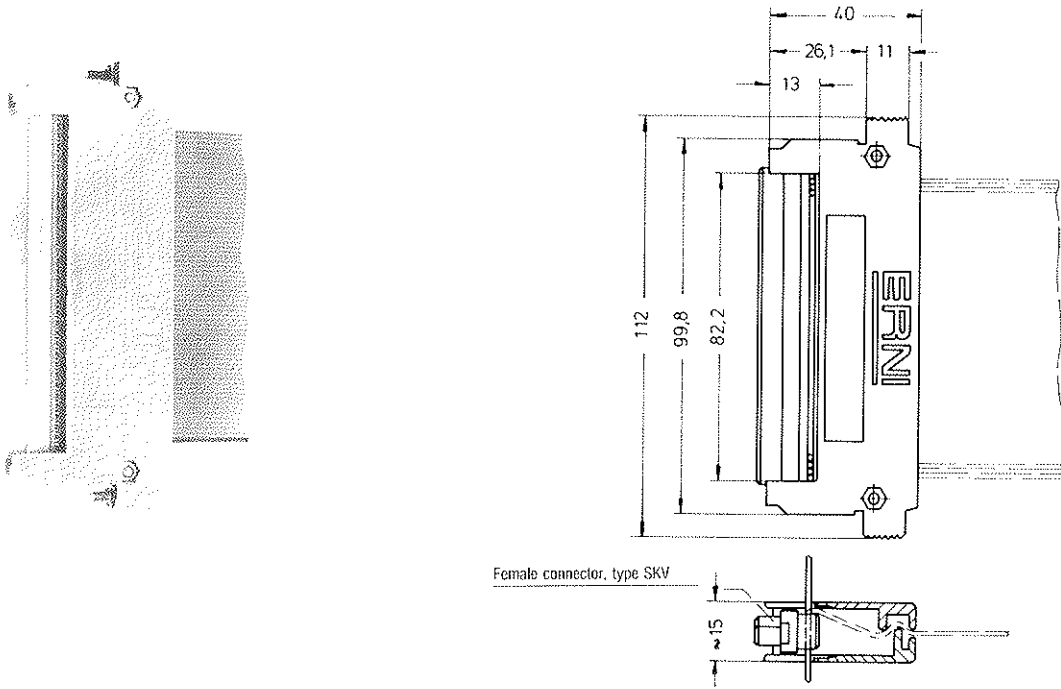

#### Cable entry at rear

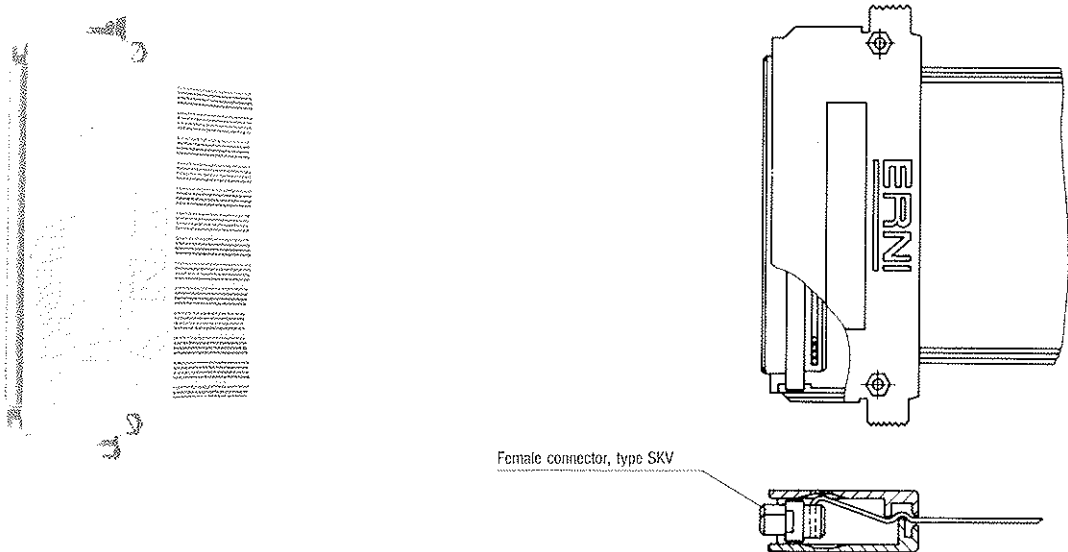

## Dimensions

### Cable housings KSG 253 to carry small electronic circuits

LEDs can be fitted at the rear of the cable housing for the visual indication of fault signals or switch positions.

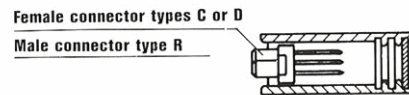
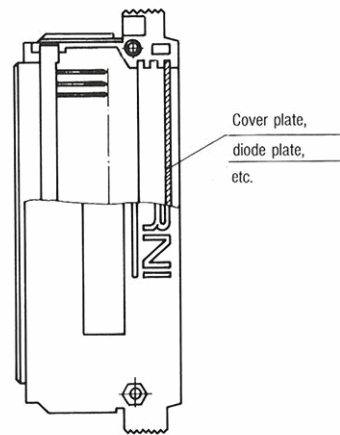

### Cover plates for fitting diodes

#### KSG 173 (3T) KSG 203

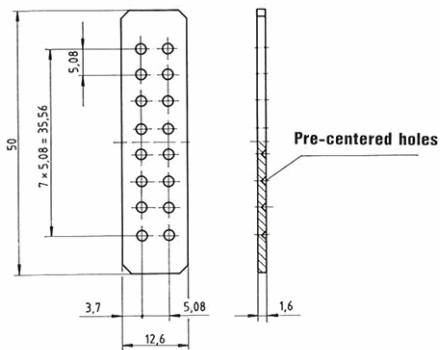

#### KSG 173 (4T)

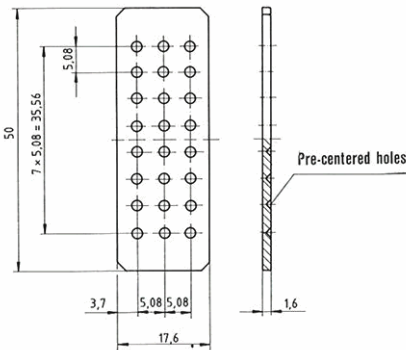

#### KSG 253

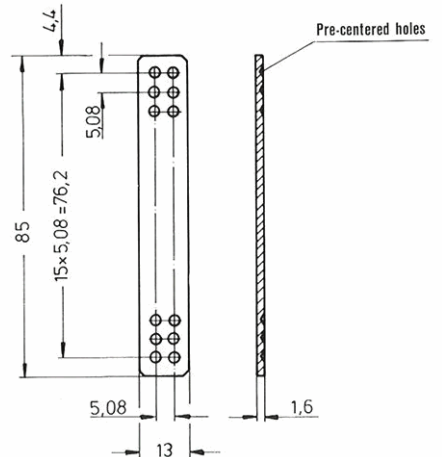

## Technical data, coding system

Cable housings KSG 173, 203, 253, 193  
for connectors to DIN 41 612 and VG 95 324

### Technical data

Moulding material	Polycarbonate 30 % GFR
Application class	EKD DIN 40 040
Temperature range	-65°C to +125°C
Inflammability	UL 94 V-1
Metal parts	Steel, surface treated

### Coding system

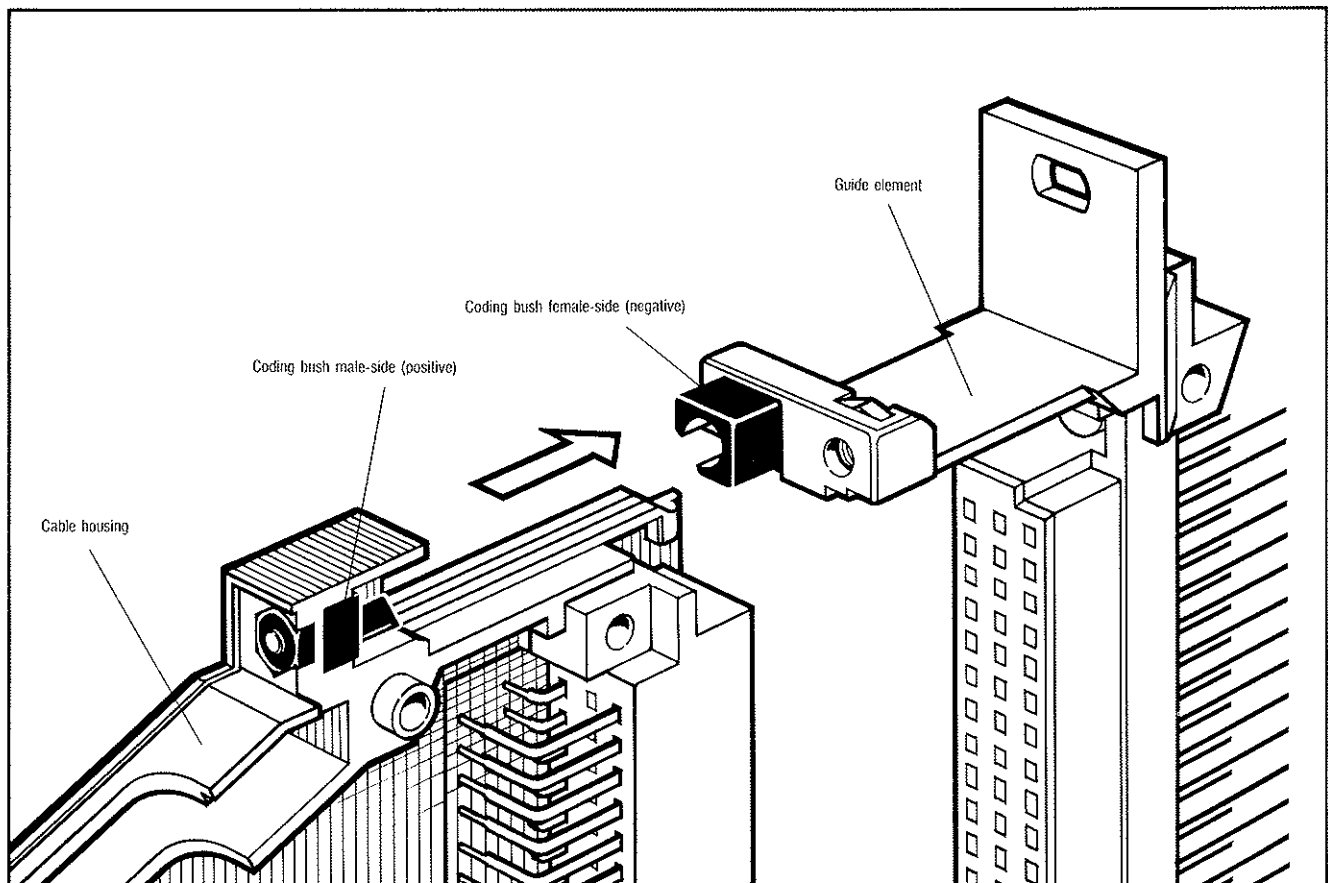

### Packing

As component set packed in a bag;  
2 coding bushes positive  
2 coding bushes negative  
and fastening elements

### Part-No.

033 004



## Individual parts, ordering details

**Cable housings KSG 173, 203, 253  
for male and female connectors to DIN 41 612**

### Individual parts

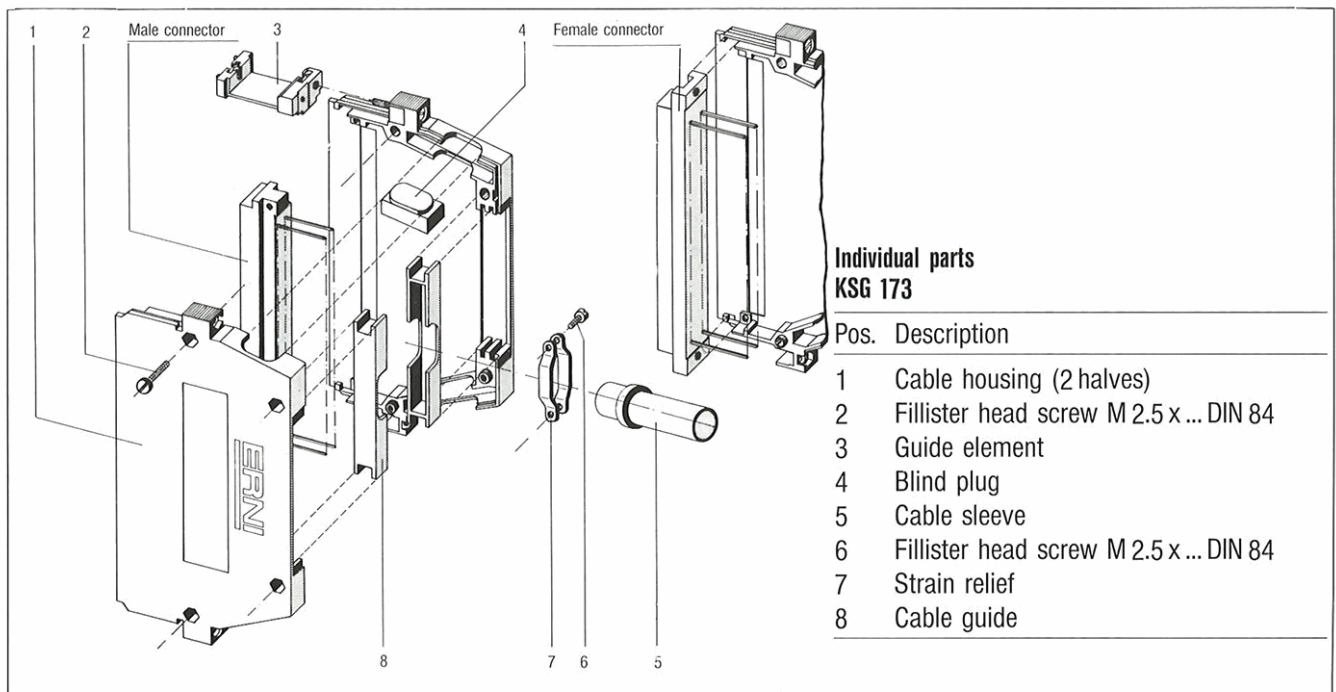

**An adaptor element is necessary for fitting types B and Q.**

### Order details

Cable housing	Number of cable outlets	For connector type	Part-No.
KSG 173	1	B, C, D, H11, Q, R	173 001
KSG 173	2	B, C, D, H11, Q, R	173 002
KSG 173	1	E	173 051
KSG 173	2	E	173 052
KSG 173	1	H15	414 886
KSG 173	2	H15	414 888
KSG 203	1	F	203 001
KSG 203	2	F	203 002

Cable housings with 3 cable outlets on request

Cable housing	Version	For connector type	Part-No.
KSG 253	Outlets at rear and both sides	C Insulation Displacement Connectors	253 001
KSG 253	Outlet at rear	C Insulation Displacement Connectors	253 002
KSG 253	for cover plate	C, D, R	253 004

Cover plate for KSG 173 (3T)  
Cover plate for KSG 173 (4T)  
Cover plate for KSG 253  
Adaptor for fitting male or female connectors type B and or Q into KSG 173

**Part-No.**  
**173 114**  
**173 115**  
**253 117**  
**173 117**

**Special patterns for particular requirements on request.**

## Guide elements

### Guide elements for front panel connection with connector types B, C, D, E, F, H 11, H 15, Q, R

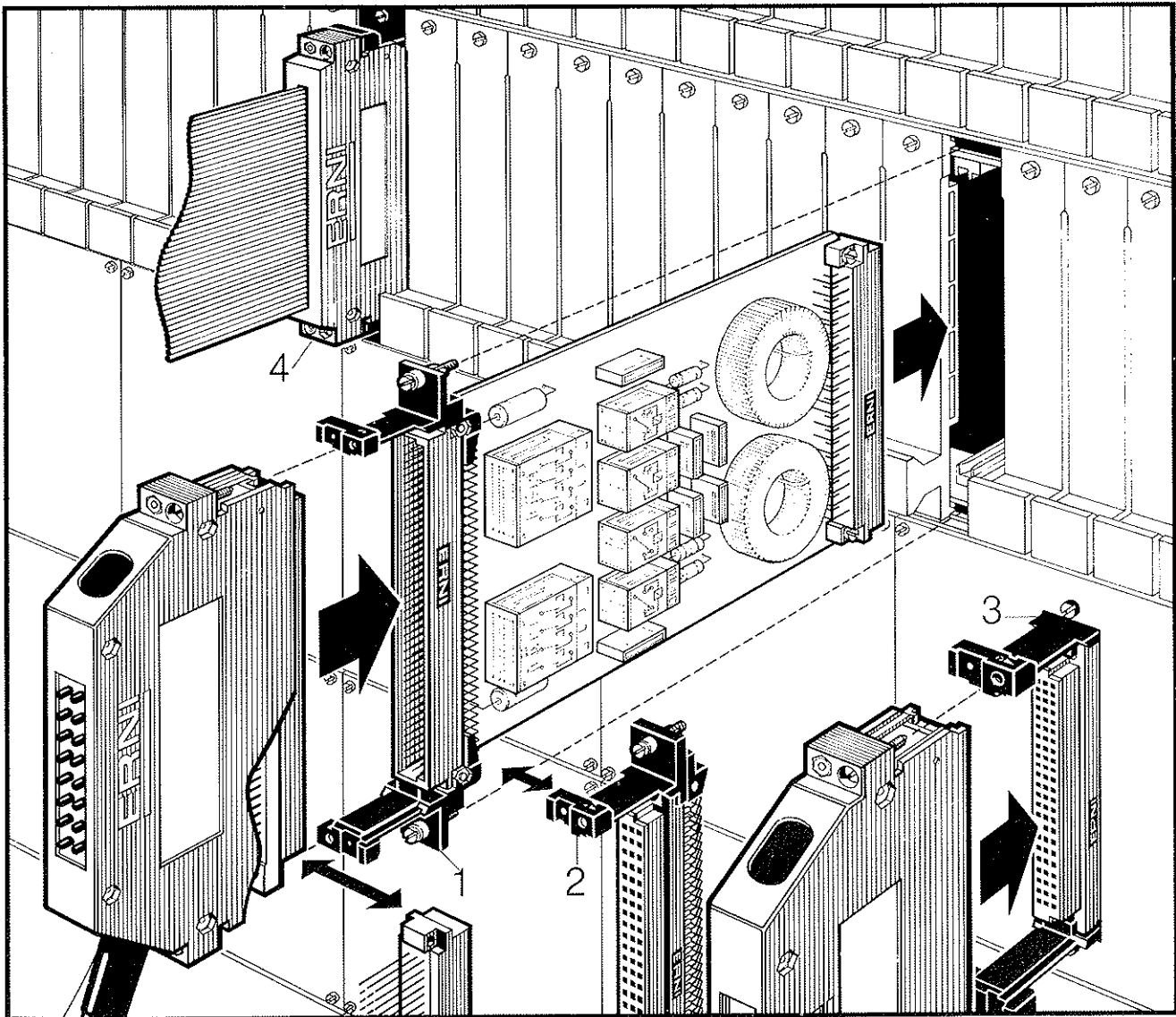

This interface system gives users the opportunity of providing mateable connections on the front-panels. The guide elements can either be fitted as pull grips or be mounted on metal front panels.

Fitting mateable connectors to the front of PCB modules makes it possible to separate the internal and external wiring and to provide mateable connections between different modules, cabinets or other peripheral equipment.

This front-side interface system makes it possible to transmit sensitive signals without interferences.

For PCB-drillings please see page 19 – „Front mountings“.

#### Explanation – Installation possibilities

- Pos. 1 Guide elements fitted as a card-edge grip for mounting a male connector resp. inverted female connector (the female connector resp. inverted male connector being in the cable housing).
- Pos. 2 Guide elements fitted as a card-edge grip for the mounting of a female connector with angled solder pins (the male half being in the cable housing).
- Pos. 3 As Pos. 1 and 2 but for mounting on a front panel. For the panel cutout see page 11.
- Pos. 4 The guide elements are also suitable for cable housing KSG 253 (the female half being in the cable housing).

## Order details, mounting cutouts

### Order details for guide elements (sets)

Pos.	Guide element for	Type	Application	Part No.
1	Male connector Female connector	B, C, D Q, R, F, H 11, H 15	Card edge grip	043 518
1	Male connector	E	Card edge grip	043 549
2	Female connector	B, C, D, H 11	Card edge grip	043 519
2	Female connector	E	Card edge grip	043 550
3	Male connector Female connector	B, C, D Q, R	Front panel	043 520
3	Male connector	F, H 11, H 15	Front panel	043 575
3	Male connector	E	Front panel	043 551
3	Female connector	B, C, D, H 11	Front panel	043 523
3	Female connector	E	Front panel	043 552
4	Male connector	C	Card edge grip	043 518
4	Male connector	C	Front panel	043 520

### Mounting cutout

for guide element 043 520  
043 523  
043 575

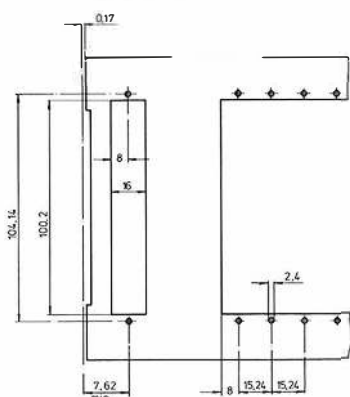

for guide element 043 551  
043 552

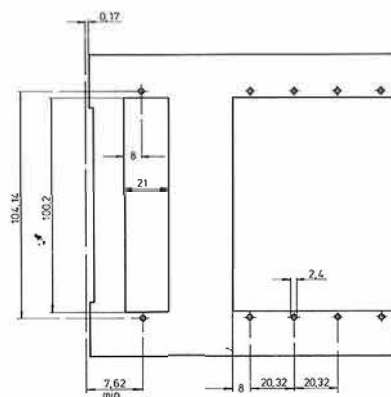

**Guide elements for mounting through wiring fields  
with connector types B, C, D, E, F, H 11, H 15, Q, R**

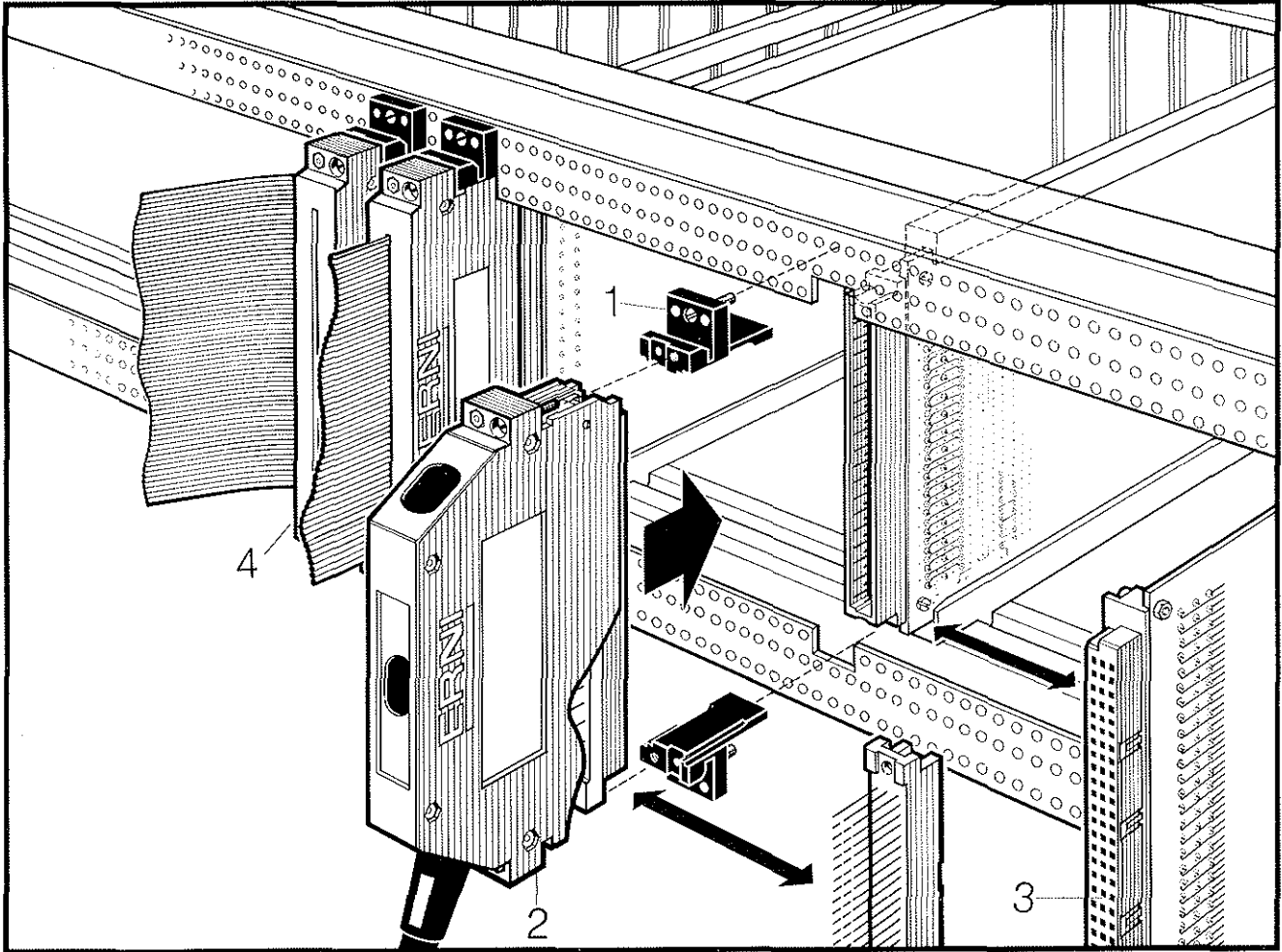

In a similar way to front-mounted connectors, this interface system also provides for making mateable interconnections directly from the wiring field to a printed circuit board. The guide elements are mounted on the rails of a subrack and serve to locate the PCB in the rack.

**Explanation – Installation possibilities**

- Pos. 1 The guide elements are fitted to the motherboard support. Alternatively, by fitting suitable spacer washers (included in the set), the guide elements can be fitted directly to a subrack.
- Pos. 2 For power connections, the female half is mounted in the cable housing and the male half and PCB in the subrack to provide protection against accidental contact.
- Pos. 3 Similar to the front-panel mounting, it is also possible to fit female connectors with right-angled terminations or reversed female connectors on the printed circuit board (male connector in the cable housing).
- Pos. 4 The guide elements are also suitable for cable housings KSG 253 (female connector in the cable housing).

## Order details, mounting cutouts

## Order details for guide elements (sets)

Pos.	Guide element for	Type	Part No.
1	Male/female conn. Female connector	B, C, D, Q, R	<b>043 553</b>
1	Male connector Female connector	E	<b>043 554</b>
1	Male connector	F, H11, H15,	<b>043 553</b>

### Mounting cutout

for guide element 043 553

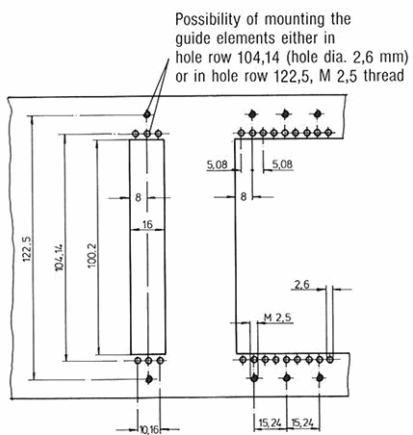

for guide element 043 554

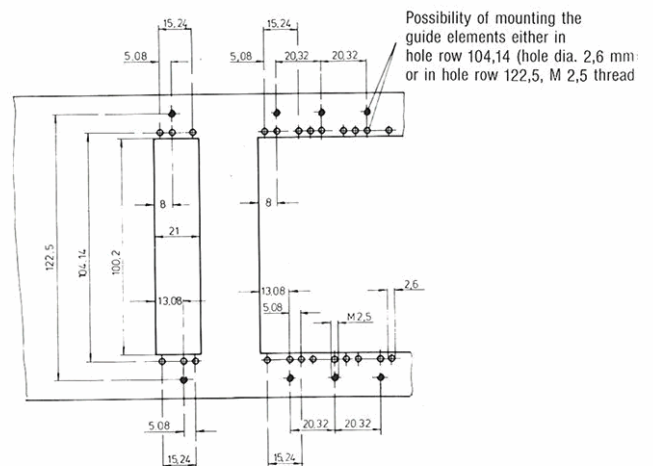

## Guide elements for mounting on mother boards or on printed circuit boards with connector types B, C, D, E, H 11, Q, R

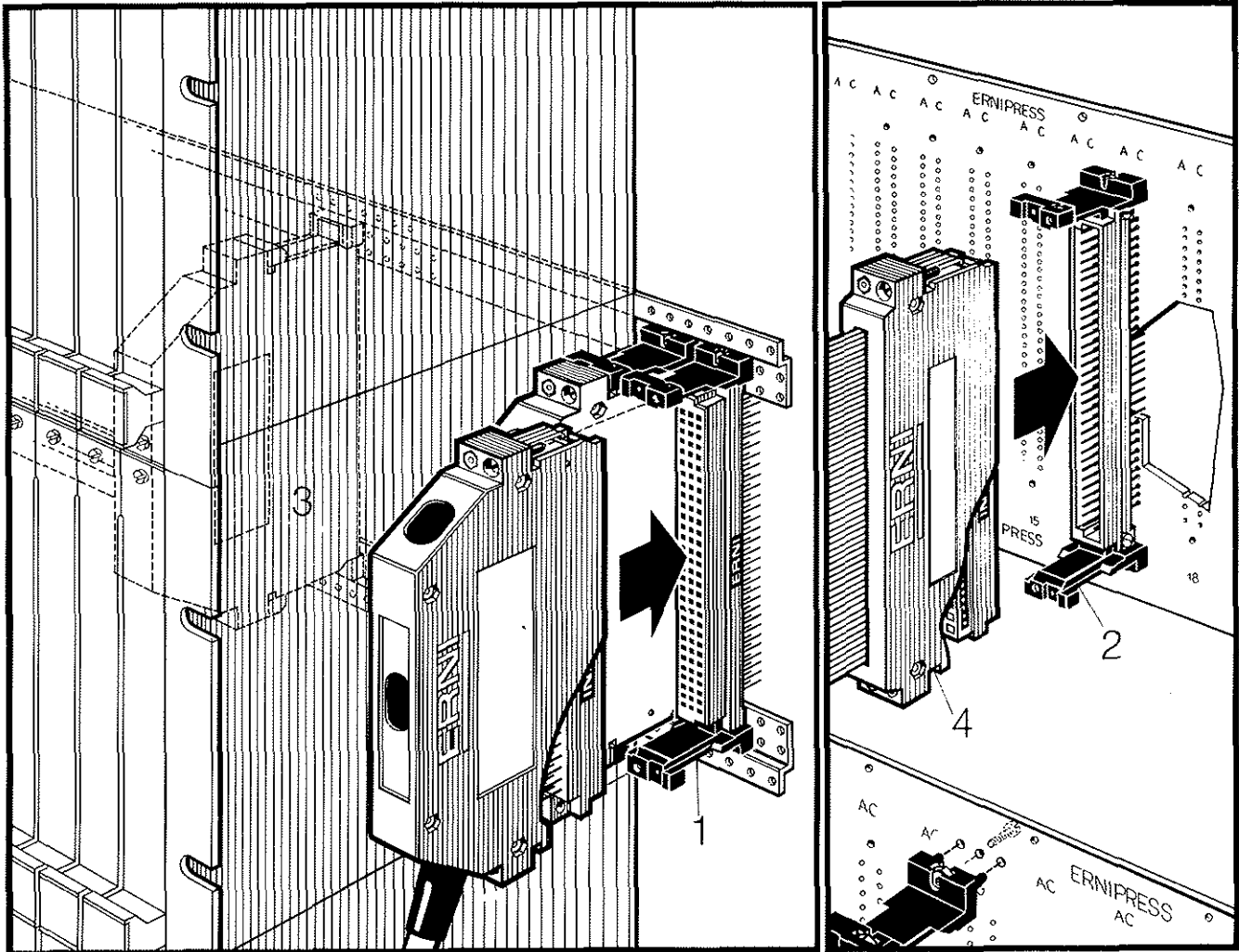

The interfacing technique shown in Pos. 1 is particularly suitable for cases and cabinets fitted with pivoting wiring frames.

The guide elements are mounted adjacent to or on the subracks.

A particular advantage of this interface system is the wide variety of wiring possibilities it offers. Depending on the method of connection used (wire wrapping, clip to clip, solder, fast-on or piggy-back) a suitable female connector or reversed male connector is mounted on the interfacing field so that the interfacing field and the wiring matrix have similar connectors. The male half or reversed female half is carried in the cable housing.

Where circuit boards are used in the wiring field as shown in Pos. 2, on which male half connectors with straight pins are fitted, the guide elements can be fastened directly on the circuit board. In such cases, the female half is carried in the cable housing.

### Explanation - Installation possibilities

- Pos. 1 The guide elements for the female half are mounted on the wiring rails, adjacent to subracks or on a printed circuit board.
- Pos. 2 The guide elements for the male half are mounted on the wiring rails adjacent to the subracks or on a printed circuit board.
- Pos. 3 The guide elements are mounted in the interior of the subrack.
- Pos. 4 The guide elements are also suitable for cable housings type KSG 253 (here the female half is mounted in the cable housing).

## Order details, mounting cutout

### Order details for guide elements (sets)

Pos.	Guide element for	Type	Part No.
1	Female connector Male connector	B, C, D, H 11 Q, R	043 555
1	Female connector	E	043 556
2	Male connector <sup>1)</sup>	B, C, D,	043 620
2	Male connector <sup>1)</sup>	E	043 619

<sup>1)</sup> Male connector with straight terminations

### Mounting cutout

for guide element 043 555  
043 620

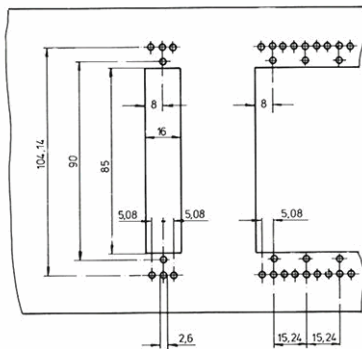

for guide element 043 556  
043 619

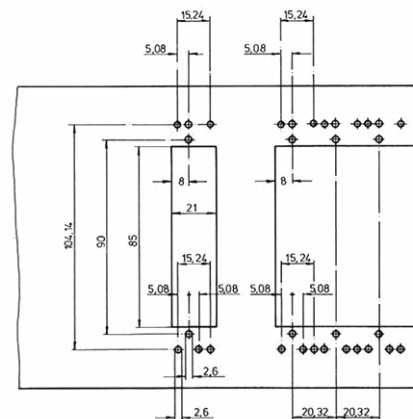

## Guide frames and spacer elements for fitting in the wiring plane for use with connector types B, C, D, E, Q, R

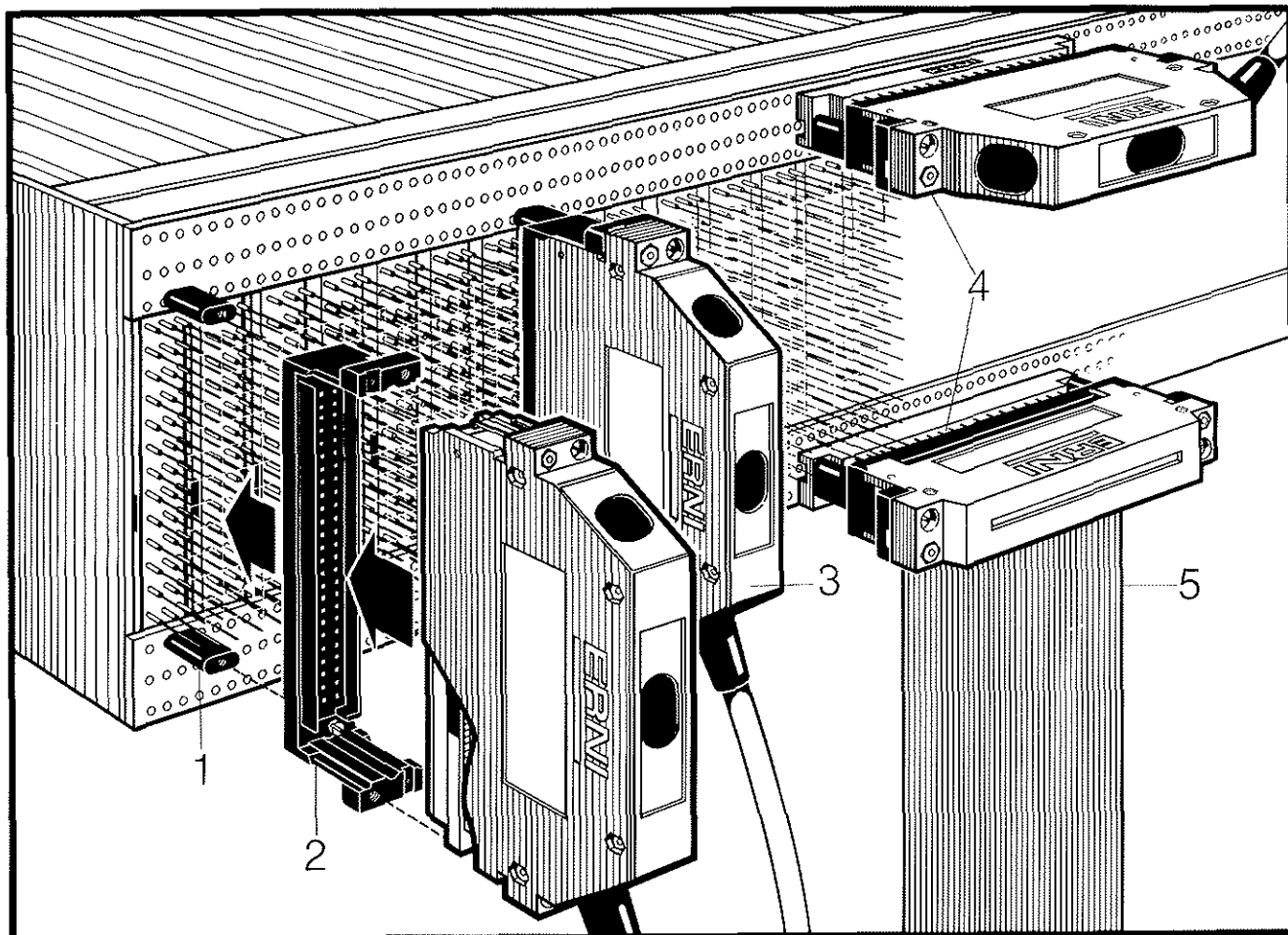

With this interface system, mateable interconnections can be provided on the wiring end between the internal wiring and the external wiring. Such connections can either be provided directly on the wiring plane or on the top or bottom edge fields.

Apart from the possibility of mating male connectors in cable housings to female connectors with 0,6 x 0,6 mm connection pins, wiring connector elements with 0,6 x 0,6 and 1 x 1 mm connection pins have been developed. See pages 27 - 29.

The particular advantage of these elements is their narrow width which facilitates edge mounting without any extension beyond the height of a subrack.

Where it is required to connect a female connector in a cable housing to female connectors with 1 x 1 mm wiring pins, use is made of our special female connectors types DUE and EUE which have the 1 x 1 mm pins reduced at the ends to 1 x 0,6 mm so that connection can be made to them using female connectors to DIN 41 612.

For dimension drawings of types DUE and EUE see our brochure „Technical Data for DIN 41 612/VG 95 324 connectors.”

For ordering data of types DUE and EUE see „Summary of Components DIN 41 612/VG 95 324 connectors.”

### Explanation - Installation possibilities

- Pos. 1 Spacer elements are secured to female connectors type B, C, DUE, EUE or reversed male connectors types Q or R or to plug-on distribution strips on the wiring plane or mother board (ERNIPRESS).
- Pos. 2 After the wrap-connections have been made, the guide frame is screwed to the spacer elements. It serves both to center the connecting pins and to hold the cable housing.
- Pos. 3 A guide frame and spacer elements fitted in the wiring plane.
- Pos. 4 Guide frames, spacer elements and plug-on distribution strips fitted to the top and bottom edge fields.
- Pos. 5 The guide frames and spacer elements are suitable also for cable housings type KSG 253. (With the female connector in the cable housing).



## Order details

### Order details for guide frames (sets)

For connection to	Part No.
Female connectors types B, C, DUE Male connectors types Q, R Wiring elements VE 64, VE 96 Plug-on distribution strips SV 32	<b>033 020</b>
Female connectors type EUE Plug-on distribution strips SV 48	<b>033 021</b>
Female connectors type F*)	<b>033 022</b>

### Order details for spacer elements

Mounting element fixed on subrack	For connection to	Spacer element height [mm]	Part No.
Mounting rail (2 mm thickness) Mounting in wiring plane	Female connectors type B, C Termination length 13 mm	6	<b>083 529</b>
	Female connectors type B, C Termination length 17 mm Wiring elements VE 64, VE 96	9	<b>083 525</b>
	Plug-on distribution strips SV 32, SV 48 Female connectors type DUE, EUE	17,5	<b>083 527</b>
Mounting rail (2 mm thickness) Mounting on edge field	Plug-on distribution strips SV 32, SV 48	19,5	<b>083 533</b>
	Wiring elements VE 64, VE 96	11	<b>083 526</b>
Circuit board 3.2 mm thickness 2.4 mm thickness	Female press-fit connectors types B, C, Termination length 17 mm Male reversed press-fit connectors types Q, R, Termination length 17 mm	8	<b>083 531</b>
	Male reversed press-fit connectors types Q, R, Termination length 20 mm	11	<b>083 526</b>
	Female press-fit connectors types D, E, Termination length 26 mm	16	<b>083 535</b>
Mounting rail (2 mm thickness)	Female connectors type F*)	22,5	<b>083 528</b>

\*) Female connectors for plugging on are not included in the ERNI range of products.

## Application examples

### Cable housing KSG 173

This cable housing is also suitable for holding electronic circuits

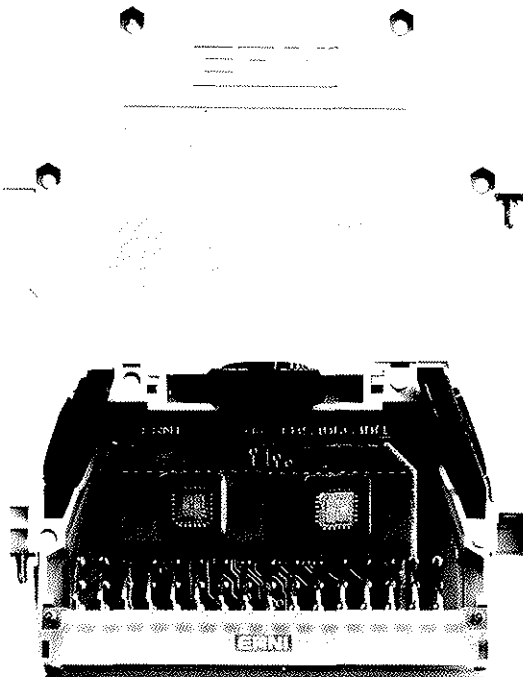

1. KSG 173 as a memory cassette, for example, for machine controls.

Here 2 EPROMS are soldered together with a 32-pole male connector to a circuit board. The storage capacity in this example is 2K x 16 bit.

These memories retain their data over many years without any power supply.

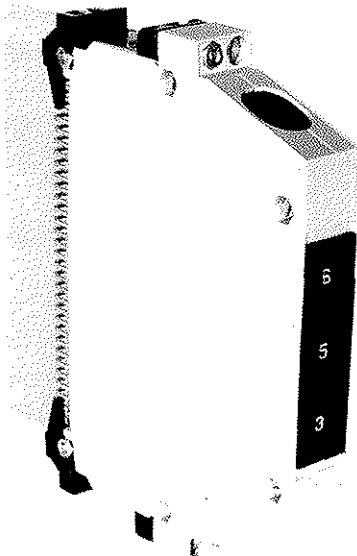

2. KSG 173 (3T) fitted with a pre-selector switch VS 632.

The switch units are mounted one above another and can be snapped into the cable housing to lock in place.

The dimensions of the switch units exactly match those of the opening in the cable housing so that no modification to the KSG 173 necessary.

These selector switches provide for directly influencing a control by the digital input of numerical values and provide at the same time a visual indication of the switch positions.

# Circuit board drilling pattern

for male and female connectors to DIN 41 612  
with right-angled connecting pins

View of equipment side

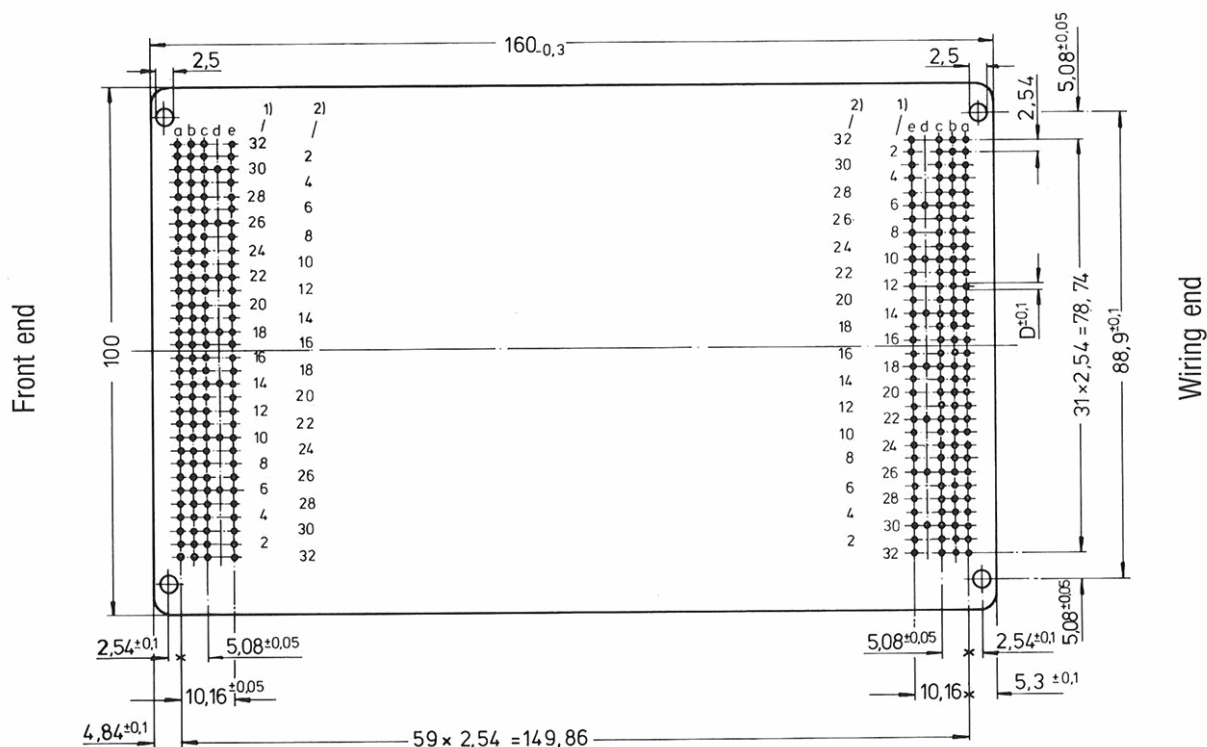

Type	No. of poles	Rows occupied	Equipped with contacts	D [mm]
B, Q	64	ab	Complete	1,0
B, Q	32	ab	Even numbered	1,0
C, R	96	abc	Complete	1,0
C, R	64	a c	Complete	1,0
C, R, D	32	a c	Even numbered	1,0
E	48	a c e	Even numbered	1,0
E	48	abc	Even numbered	1,0
F	48	abc	Even numbered	1,0
H11	11	e	2-5-8...26-29-32	1,6
H15	15	b d	b: 4-8-12-16-20-24-28-32 d: 6-10-14-18-22-26-30	1,6

- 1) Hole pattern drawing for male connectors and reversed female connectors to DIN 41 612.
- 2) Hole pattern drawing for female connectors with right-angled connection pins.

## Cable housing KSG 193

for male and female connector types BK and CK to VG 95 324  
(half length VG connectors)

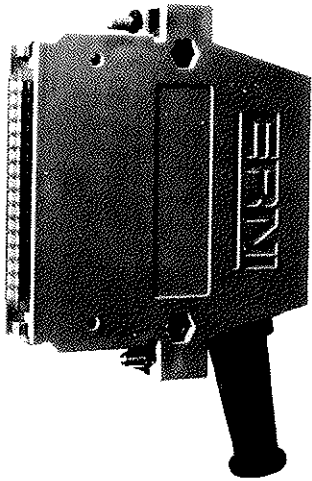

An adaptor is necessary  
when fitting type BK

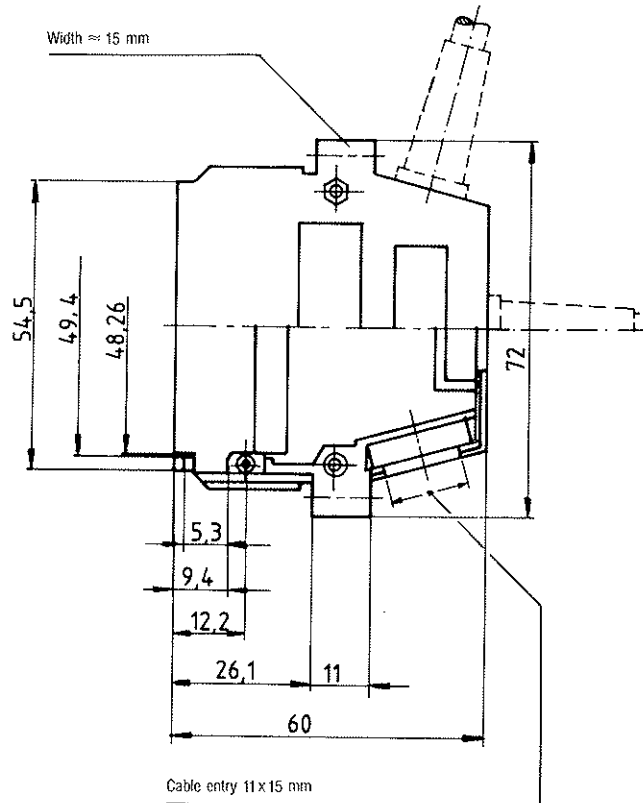

### Order details

Designation	Number of Cable entries	Type	Part No.
KSG 193	1	BK, CK	193 001
KSG 193	2	BK, CK	193 002
Adaptor	—	BK	193 117

Cable housings with 3 cable entries  
on request.

## Guide elements for front mounting with connector types BK or CK (half-length VG connectors)

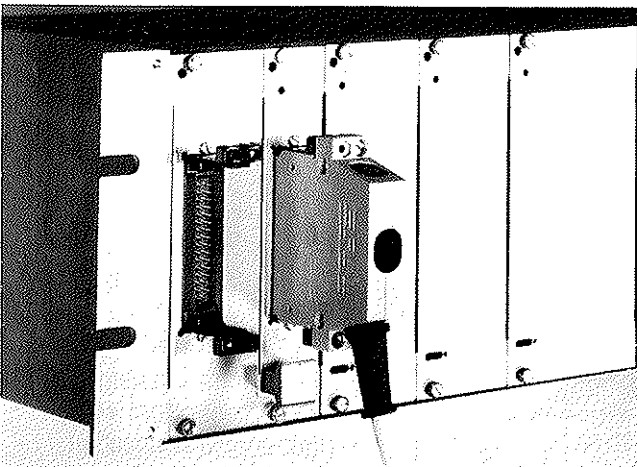

This interface system gives users the opportunity of providing mateable connections on the front-panels.

Fitting mateable connectors to the front-panels of PCB modules makes it possible to separate the internal and external wiring and to provide mateable connections between different modules, cabinets or other peripheral equipment.

This front end interface system makes it possible to transmit sensitive signals without interferences.

For circuit-board hole pattern see page 26 „Front end“.

## Dimensions, order details and mounting cutouts

### Dimensions

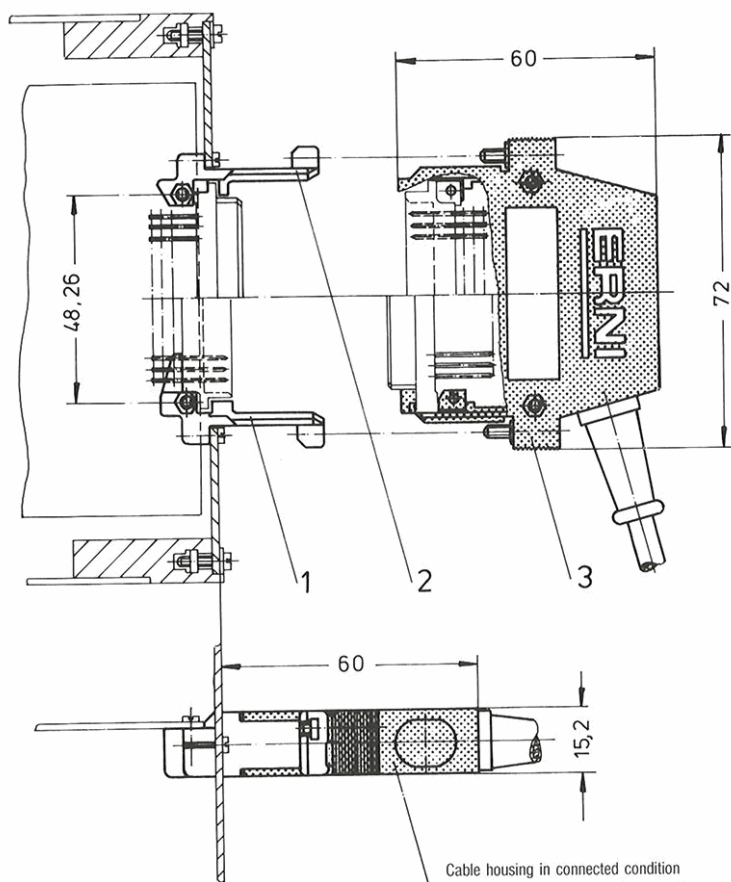

- Pos. 1 Guide element for fitting male connectors (female connector in the cable housing).
- Pos. 2 Guide element for fitting female connectors (male connector in the cable housing).

### Order details for guide elements (sets)

Pos.	Guide element for	Type	Part No.
1	Male connector	BK, CK	043 520
2	Female connector	BK, CK	043 523

**Mounting cutout**  
for guide element 043 520  
043 523

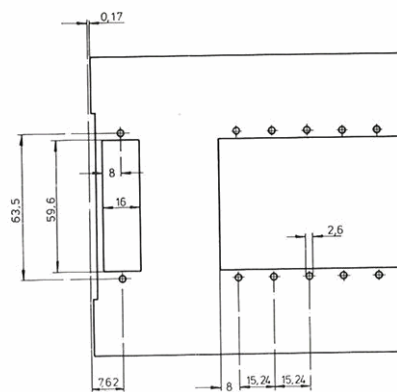

## Guide elements for mounting type BK and CK connectors (half-length VG connectors) on wiring planes

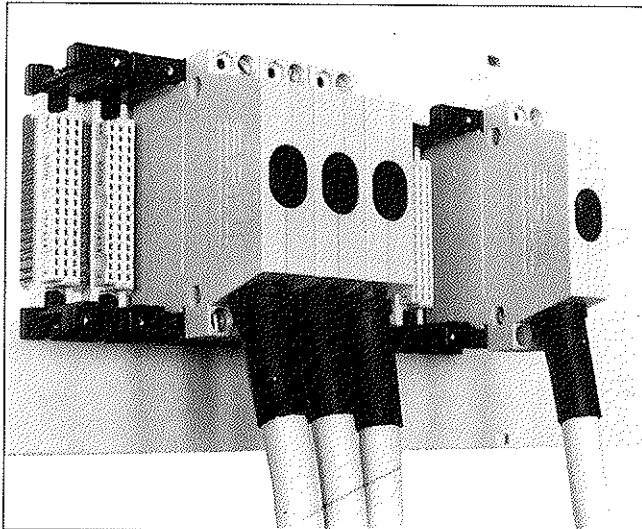

A particular advantage of this method of interconnection wiring is the wide variety of wiring methods that are possible. A female connector type chosen to suit the wiring method used (wire wrapping, solder, fast-on or piggy-back connections) is fitted in the interconnection field.

Thus the interconnection field and the wiring plane have identical terminations. The **male half** of the connector is carried in the cable housing.

Where the wiring plane is fitted with printed circuit boards on which male connectors with straight pins are fitted, the guide elements can be mounted directly on the printed circuit board. In this case, the **female connector** is carried in the cable housing.

(See Page 14, Pos. 2)

## Dimensions

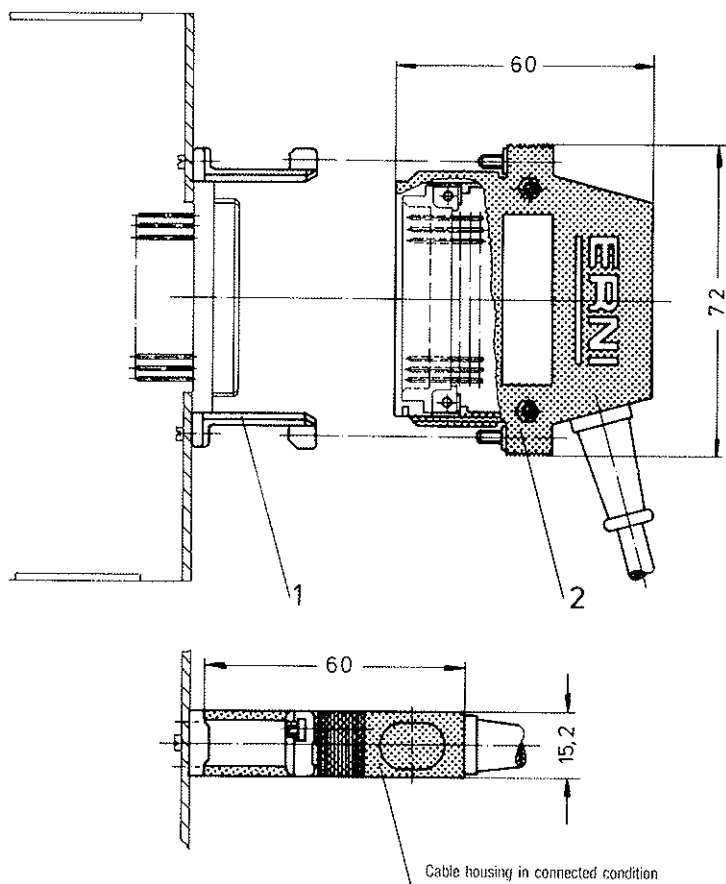

## Order details, mounting cutout

### Order details for guide elements (set)

Pos.	Guide element for	Type	Part No.
1	Female connector	BK, CK,	043 555
1	Male connector <sup>1)</sup>	BK, CK	043 620

<sup>1)</sup> Male connector with straight terminations

### Mounting cutout

for guide elements 043 555  
043 620

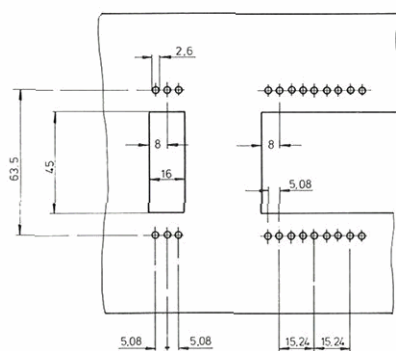

## Guide elements for fitting with connector types BK and CK (half-length VG connectors) in the wiring plane

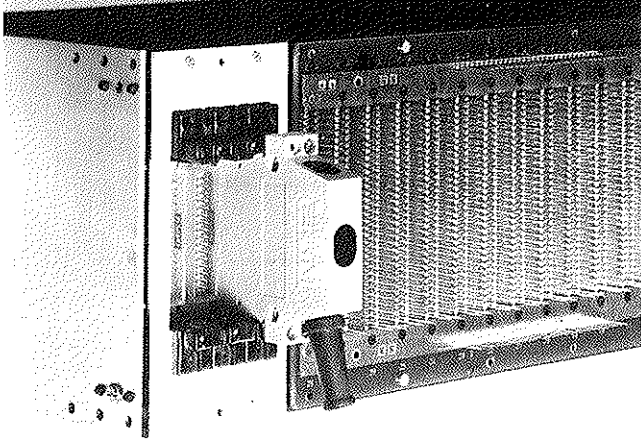

In a similar way to front-mounted connectors, this interface system also provides for making mateable interconnections directly from the wiring end to a printed circuit board. The guide elements are mounted on the mother board and serve to locate the card in the rack.

### Explanation

The guide elements are mounted on the motherboard. Similar to front-panel mounting, female connectors with right-angled connections can be mounted directly on the printed circuit board and the male connector is then located in the cable housing.

For power connections, the female half is mounted in the cable housing and the male half and circuit board in the subrack to provide protection against accidental contact.

### Dimensions

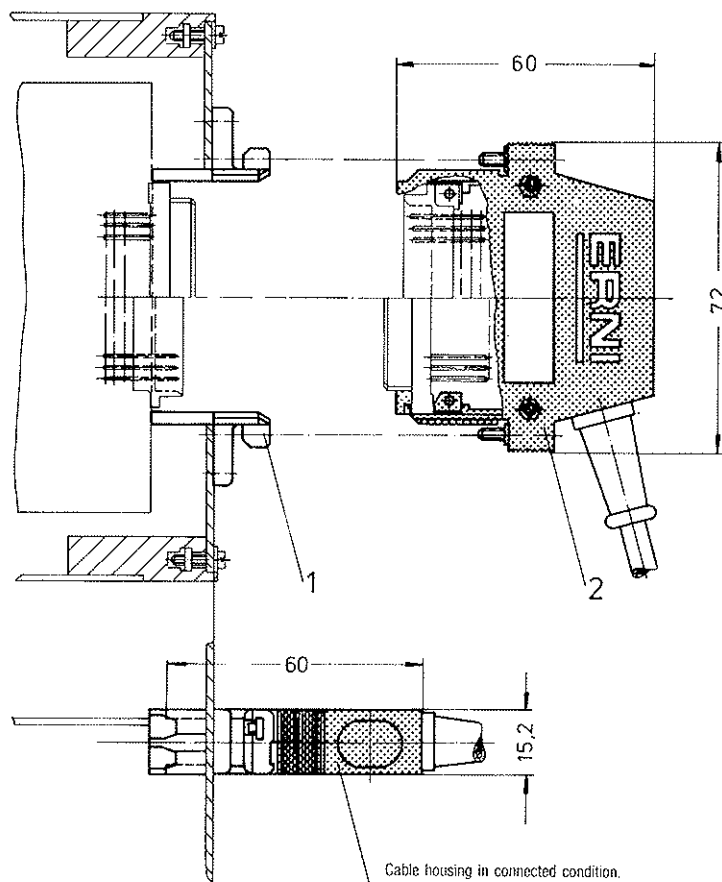



## Order details, mounting cutout

### Order details for guide elements (sets)

Pos.	Guide element for	Type	Part No.
1	Male connector Female connector	BK, CK	043 553

### Mounting cutout

for guide element 043 553

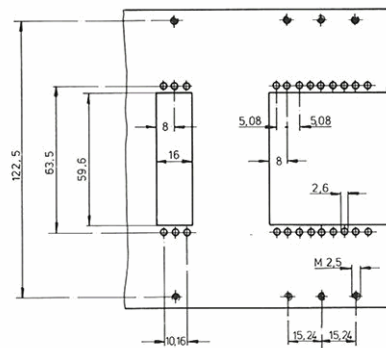

## Circuit board drilling pattern

for male and female connectors type BK and CK  
(half-length VG connectors) with right-angled connecting pins

### View of equipment side

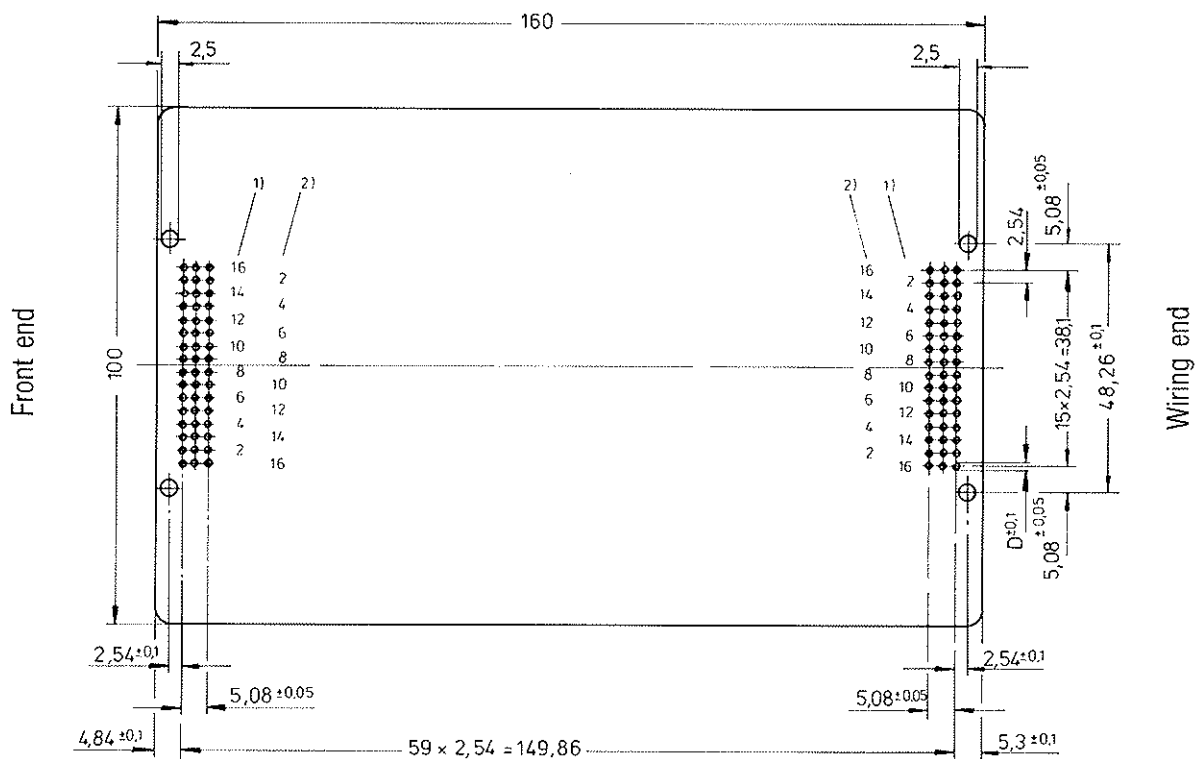

Type	No. of poles	Rows occupied	Equipped with contacts:	D [mm]
BK	32	ab	Complete	1,0
BK	16	ab	Even numbered	1,0
CK	48	abc	Complete	1,0
CK	32	a c	Complete	1,0
CK	16	a c	Even numbered	1,0

- 1) Hole pattern drawing for male connectors BK and CK to VG 95 324.
- 2) Hole pattern drawing for female connectors BK and CK with right-angled connecting pins.

## Wiring strips and plug-on distribution strips

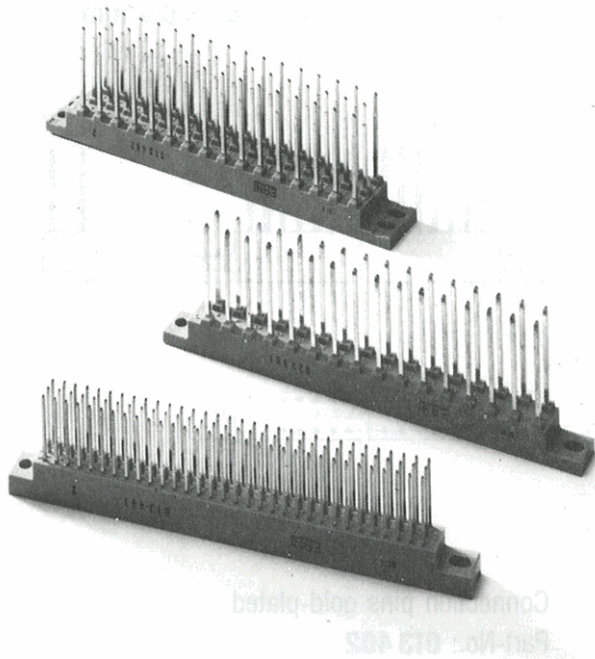

19" subracks have space for mounting female connectors to DIN 41 612 vertically in the wiring plane while the top and bottom edge wiring fields have room for mounting wiring strips and plug-on distribution strips horizontally. These strips are also suitable for mounting in the wiring plane. The wiring strips VE 64 and VE 96 with gold-plated 0,6 x 0,6 mm connection pins on a 2,54 mm grid are suitable for plugging on female connectors type C to DIN 41 612.

Wiring elements VE 32 and VE 48 with 1 x 1 mm connection pins on a grid of 5,08 mm are suitable for use as distribution strips.

The plug-on distribution strips SV 32 and SV 48 facilitate the internal and external wiring of subracks on the wiring side. The 1 x 1 mm wire-wrap pins are similar to those of the wiring strips but they are reduced to 1 x 0,6 mm in the contact area so that female connectors type C, D, or E to DIN 41 612 can be plugged on to the ends of these reduced pins.

### Electrical and mechanical characteristics

Type	VE 64	VE 96	VE 32	VE 48	SV 32	SV 48
No. of poles	64	96	32	48	32	48
Application class	EKD DIN 40 040					
Temperatur range	-65°... +125°C					
Perm. relative humidity	Yearly average $\leq$ 80 %, max. 100 %					
Minimum creep path	1,8 mm		6 mm			
Minimum air gap	1,8 mm		4 mm			
Working current at						
+ 20°C	4 A				5,5 A	
+ 70°C	2 A				4 A	
+100°C	1 A				2 A	
Test voltage 50 Hz, 1 min.	1000 V <sub>eff</sub>		3000 V <sub>eff</sub>			
Insulation resistance	10 <sup>12</sup> Ω		10 <sup>12</sup> Ω			
Insulation material	Polycarbonate 30 % GFR					
Inflammability	Self-extinguishing to UL 94 V-1					

## Wiring strips

### Dimensions, ordering information

#### Wiring strips VE 96-abc-0,6 x 0,6 mm

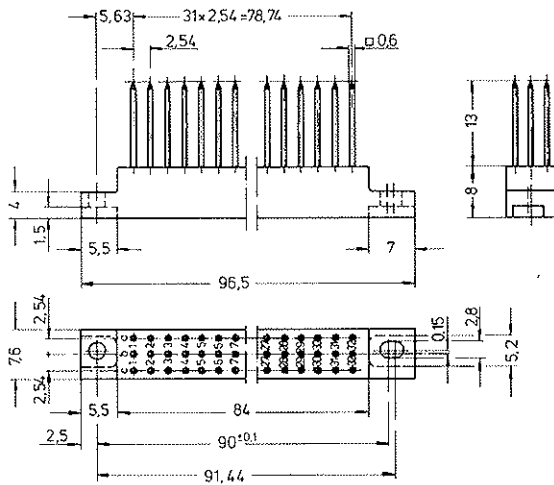

Connection pins gold-plated

Part-No.: **013 401**

#### Wiring strips VE 64-ac-0,6 x 0,6 mm

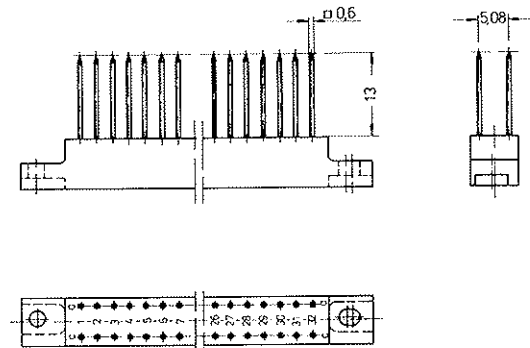

Connection pins gold-plated

Part-No.: **013 402**

#### Wiring strips VE 32-ac-1 x 1 mm

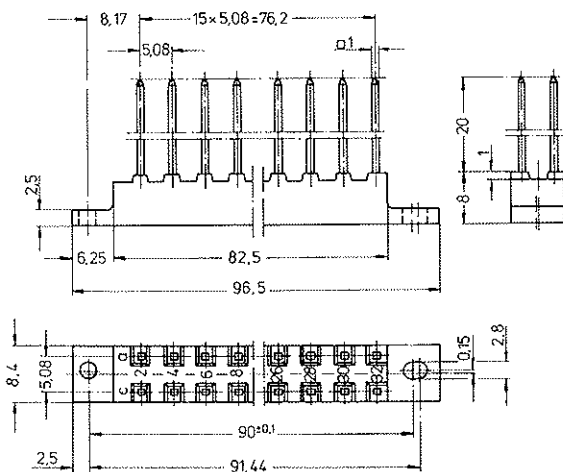

Connection pins tin-plated

Part-No.: **023 801**

#### Wiring strips VE 48-ace-1 x 1 mm

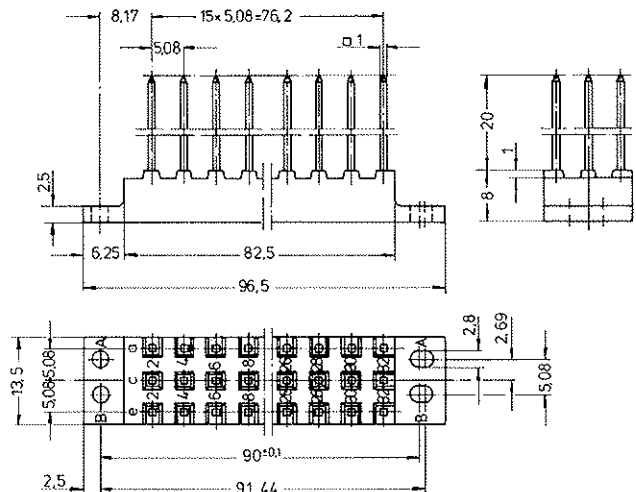

Connection pins tin-plated

Part-No.: **023 802**

**Plug-on distribution strips**  
**Dimensions, ordering information**

**Plug-on distribution strip**  
**SV 32-ac-1 x 1/1 x 0,6 mm**

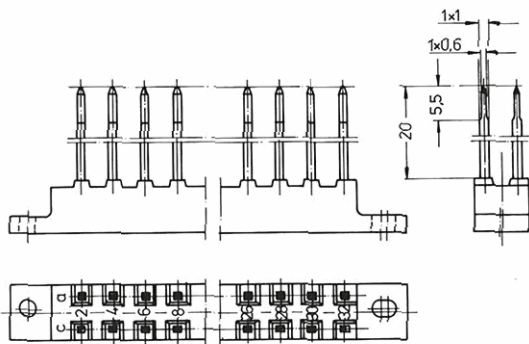

Remaining dimensions as for  
wiring strip VE 32-ac-1 x 1

Connection pins gold-plated  
Part-No.: **113 401**

**Plug-on distribution strip**  
**SV 48-ace-1 x 1/1 x 0,6 mm**

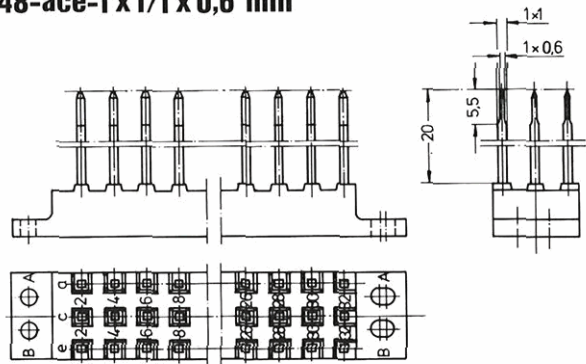

Remaining dimensions as for  
wiring strip VE 48-ace-1 x 1

Connection pins gold-plated  
Part-No.: **113 402**

---

## Index of Part-Nos.

Part-No.	Page	Part-No.	Page
013 401	28	083 527	17
013 402	28	083 528	17
023 801	28	083 529	17
023 802	28	083 531	17
033 004	8	083 533	17
033 020	17	083 535	17
033 021	17	113 401	29
033 022	17	113 402	29
043 518	11	173 001	9
043 519	11	173 002	9
043 520	11, 21	173 051	9
043 523	11, 21	173 052	9
043 549	11	173 114	9
043 550	11	173 115	9
043 551	11	173 117	9
043 552	11	193 001	20
043 553	13, 25	193 002	20
043 554	13	193 117	20
043 555	15, 23	203 001	9
043 556	15	203 002	9
043 619	15	253 001	9
043 620	15, 23	253 002	9
043 574	11	253 004	9
043 575	11	253 117	9
083 525	17	414 886	9
083 526	17	414 888	9



## Notes

**ERNI Elektroapparate GmbH**  
**P.O. Box**  
**D-73099 Adelberg**  
**Phone (07166) 50-0**  
**Fax (07166) 50119**  
**Telex 727759**

**Our products:**

Two-part connectors to DIN 41 612 and VG 95 324,  
Press-fit connectors,  
SMD connectors,  
Miniature connectors with 1.27 mm pitch,  
**ER<sub>mei</sub>**, 2.0 mm interconnection system,  
Fibre optic cable connectors,  
Subminiature D connectors,  
ERNIPRESS systems including PC Boards to customer's  
specifications plus a complete interfacing system for all connectors,  
Modular connector housing system for 6, 8, 14, 30, 64 and 96 pins,  
LDG series of DIN rail mountable miniature enclosures,  
Insulation displacement connectors for 10-96 pins,  
Pin connectors, 1-100 pins,  
Print relays with 1, 2 and 4 changeover contact elements,  
Hybrid relays with electronic input section,  
Miniature rotary code-selection switches,  
Miniature rotary stepping switches,  
Low-profile switches