

REVISIONS					
P	LTR	DESCRIPTION	DATE	DWN	APVD
	K12	ECN-22-152117	05MAY2022	RK	CDS

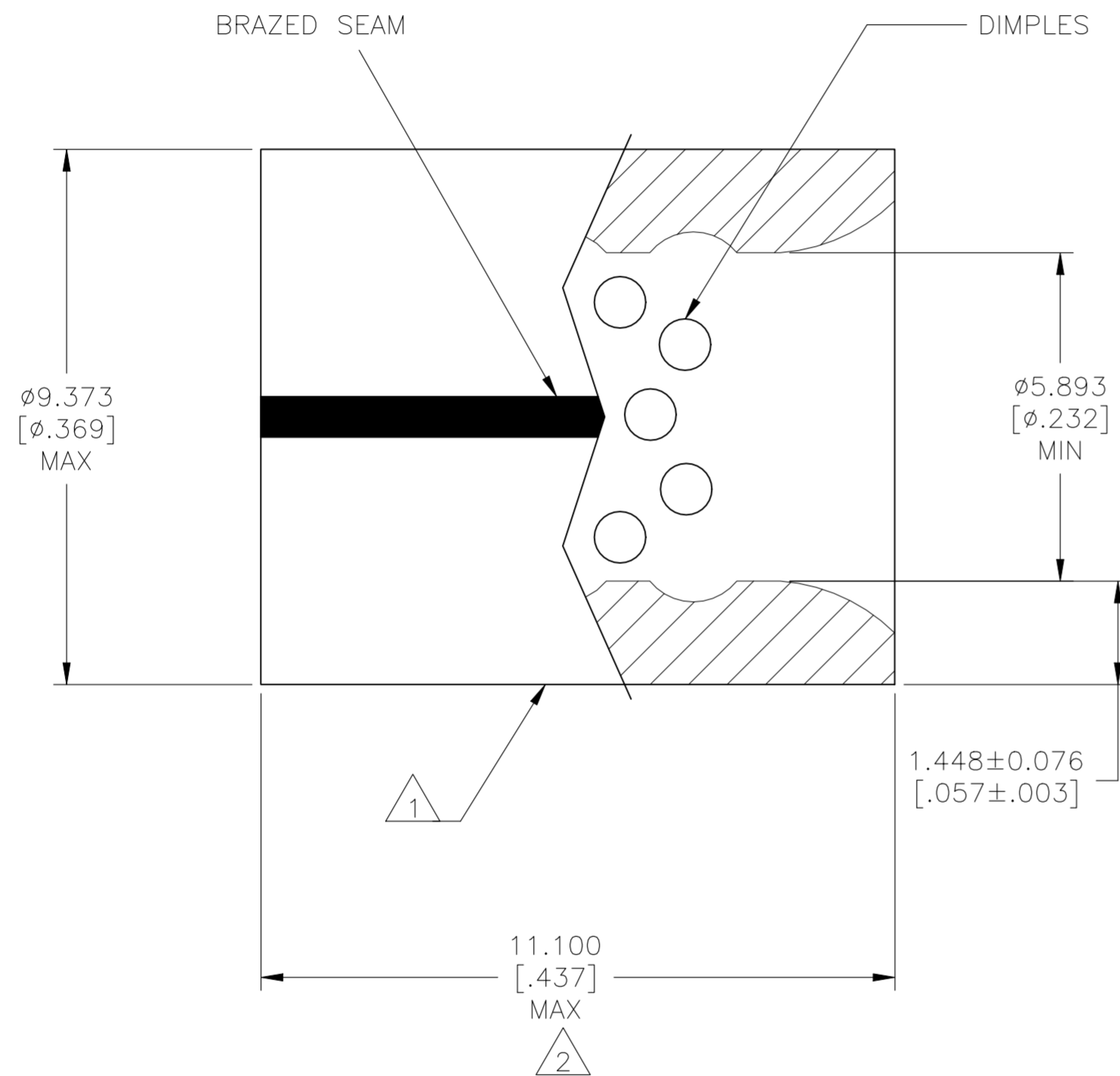
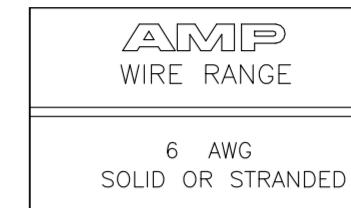

- 1 STAMP AMP 6W\* APPROX AS SHOWN.
- 2 MAXIMUM LENGTH DOES NOT INCLUDE MANUFACTURING TABS.
- 3 MATERIAL: COPPER PER ASTM B152 ANNEALED.
- 4 UL LISTED E13288, 6 AWG STRANDED.
- 5 CSA CERTIFIED LR7189, 6 AWG SOLID OR STRANDED.
- 6 0.00254 [.000100] MIN. EXT. THK. TIN PLATE PER ASTM B545.
- 7 TIN/LEAD PLATE (60/40) 0.00254 [.000100] MIN. EXT. THK. PER SAE AMS-P-81728.
- 8 GOLD PLATE 0.00127[.000050] MIN. EXT. THK. PER ASTM B488, TYPE 1, CODE C OVER NICKEL PLATE 0.00127[.000050] MIN. EXT. THK. PER SAE AMS-QQ-N-290 OVER Cu FLASH PER SAE AMS2418.
- 9 NOTE DELETED.
- 10 NICKEL PLATE 0.00762[.000300] MIN. EXT. THK. PER SAE AMS-QQ-N-290.

MAX. OPERATING TEMP.	APPROVALS	QTY	FINISH	PACKAGE TYPE	PART NO.
343°C[650°F]	---	500	10	LOOSE PIECE	34319-4
260°C[500°F]	---	500	8	LOOSE PIECE	34319-3
170°C[338°F]	---	100	7	LOOSE PIECE	34319-1
170°C[338°F]	4 5	500	6	LOOSE PIECE	34319

AMP INCORPORATED CUSTOMER SERVICE SYSTEMS		MAX RECOMMENDED OPERATING TEMPERATURE: SEE TABLE
FOR ADDITIONAL PRODUCT INFORMATION OR COPIES OF DRAWINGS AND TECHNICAL DOCUMENTS	PRODUCT INFORMATION CENTER 1-800-522-6752	VOLTAGE RATING: N/A
FOR APPLICATION TOOLING INFORMATION	TOOLING ASSISTANCE CENTER 1-800-722-1111	CIRCULAR MIL AREA: 10.5-16.8mm²[20,800-33,100] SOLID OR STRANDED
FOR ORDER ENTRY	1-800-526-5142	THIS DRAWING IS A CONTROLLED DOCUMENT FOR AMP INCORPORATED. IT IS SUBJECT TO CHANGE AND THE CONTROLLING ENGINEERING ORGANIZATION SHOULD BE CONTACTED FOR THE LATEST REVISION.

THIS DRAWING IS A CONTROLLED DOCUMENT.		DWN TA BRINKMAN 4-14-93	TE Connectivity	
DIMENSIONS: mm [INCHES]		CHK DA PATTERSON 4-14-93	NAME DA PATTERSON 4-14-93	
TOLERANCES UNLESS OTHERWISE SPECIFIED: 0 PLC ± - 1 PLC ± - 2 PLC ± - 3 PLC ± 0.127[.005] 4 PLC ± - ANGLES ± -		APVD DA PATTERSON 4-14-93	PRODUCT SPEC UL 486C	
MATERIAL 3		FINISH SEE TABLE	WEIGHT -	SIZE A2
			CAGE CODE 00779	DRAWING NO C-34319
			RESTRICTED TO -	SCALE 10:1
			CUSTOMER DRAWING	SHEET 1 OF 1
				REV K12