

Abstract

Features

- Based on an ultra-low power BLE SOC
 - ARM Cortex-M4F Core 20MHz
 - 160KB RAM
 - 512KB Flash in chip, and support external flash up to 8Mbyte
 - 32K RCOSC in chip, and support external 32K clock
- Operating Voltage: 2.7V~3.3V
- Support up to 16 IOs pinmux.
- Bluetooth Features
 - Support Bluetooth 5.0 (BLE single mode)
 - Max RF data rate 1Mbps
 - Max TX power: 7dBm
 - Min RX sensitivity: -96dBm@1Mbps
 - Support BLE Master/ Slave mode
 - Support broadcasting, data encryption, and adaptive frequency hopping
 - Support LE L2CAP
 - Support LE data length expansion
- Operating Temperature: -40°C to +105°C
- Antenna: PCB antenna or IPEX connector (Optional)

Application

- Intelligent lighting
- Smart Home Application
- Wearables
- Smart healthcare
- Portable devices

Module Type

Type	Note
EMB1082-P	PCB antenna
EMB1082-E	IPEX connector

Hardware Block

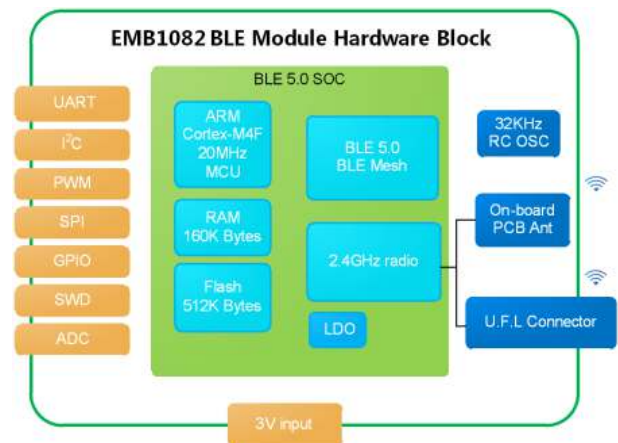

Copyright Notice

Mxchip copyrights this specification. No part of this specification may be reproduced in any form or means, without the prior written consent of Mxchip.

Version history

Date	Vision	Details
2018-10-23	1.0	Initial release
2019-03-25	1.1	Update power consumpion

Mxchip
reprint prohibited

Content

Abstract	1
Version history	1
1. Product Introduction	4
2. Pins and dimension	5
2.1 PIN ARRANGEMENT	5
2.2 PIN DEFINITION	7
3. Electrical Parameters	10
3.1 OPERATING CONDITIONS	10
3.2 POWER CONSUMPTION	10
3.3 WORKING ENVIRONMENT	11
3.4 ELECTROSTATIC DISCHARGE	11
4. RF parameters	12
4.1 BASIC RF PARAMETERS	12
4.2 GFSK PARAMETERS.....	12
5. Antenna Information	14
5.1 ANTENNA TYPE	14
5.2 PCB ANTENNA CLEARANCE ZONE	14
5.3 EXTERNAL ANTENNA CONNECTOR.....	15
6. Assembly Information and Production Guidance	16
6.1 ASSEMBLY SIZE	16
6.2 PRODUCTION GUIDANCE (IMPORTANT)	16
6.3 CONSIDERATIONS.....	18
6.4 STORAGE CONDITION	19
6.5 TEMPERATURE CURVE OF SECONDARY REFLOW.....	20
7. Reference Circuit	21
8. Module MOQ and Package Information	23
9. Sales Information and Technical Support	24

Figure Content

Figure 1 EMB1082 DIP package.....	6
Figure 2 EMB1082 half hole package	6
Figure 3 EMB1082 Package Definition.....	7
Figure 4 Minimum Clearance Zone of PCB Antenna (Unit: mm)	15
Figure 5 Size of External Antenna Connector	15
Figure 6 EWB1082 mechanical size (Unit: mm).....	16
Figure 7 Humidity Card.....	17

Figure 8 Storage Condition.....	19
Figure 9 Temperature Curve of Secondary Reflow	20
Figure 10 Power Source Circuit.....	21
Figure 11 USB to UART.....	21
Figure 12 External Interface Circuit of EMB1082	22
Figure 13 3.3V UART- 5V UART Convert Circuit.....	22

Table Content

Table 1 EMB1082 Pin Definition	7
Table 2 Range of input voltage	10
Table 3 Absolute maximum voltage rating.....	10
Table 4 EMB1082 Power Consumption	10
Table 5 Temperature and humidity condition	11
Table 6 Electrostatic Discharge Parameters.....	11
Table 7 Radio-frequency standards.....	12
Table 8 GFSK mode parameters	12
Table 9 GFSK mode RX parameters.....	12
Table 10 GFSK TX parameters.....	13

1. Product Introduction

EMB1082 is an embedded BLE module by MXCHIP. It integrates a BLE5.0 single mode SOC, including ARM Cortex-M4F Core, BLE/2.4G Radio, 160KB RAM, 512KB Flash and rich peripherals. EMB1082 uses half-hole package which is easy for soldering, and also DIP package.

Hardware diagram is shown below with three main parts:

- 32-bit Cortex-M4F Core
- BLE 2.4GHz RF
- Power management

With:

1. Up to 20MHz ARM Cortex-M4F MCU with 160KB RAM , 512KB FLASH, UART, I2C, SPI, ADC, SWD, Timer/PWM
2. RF part: support PCB antenna or IPEX connector
3. Power management: DC3.0V power supply, operating voltage range: 2.7V~3.3V

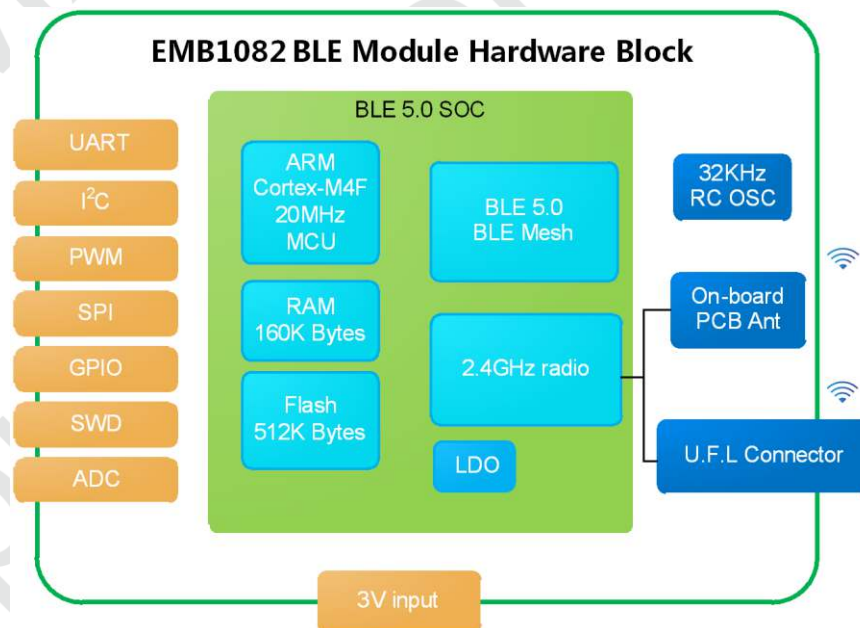

EMB1082 Hardware block

2. Pins and dimension

2.1 Pin Arrangement

EMB1082 has 21 pins, with 2.0mm pin pitch.

EMB1082 uses half-hole package and DIP package (as shown in figure 2, figure3) , which could effectively reduce the quality risk of SMT re-flow.

Solder mask openness has the same size with land. The width of solder mask is suggested to be 0.12mm to 0.14mm in SMT.

Mxchip
reprint prohibited

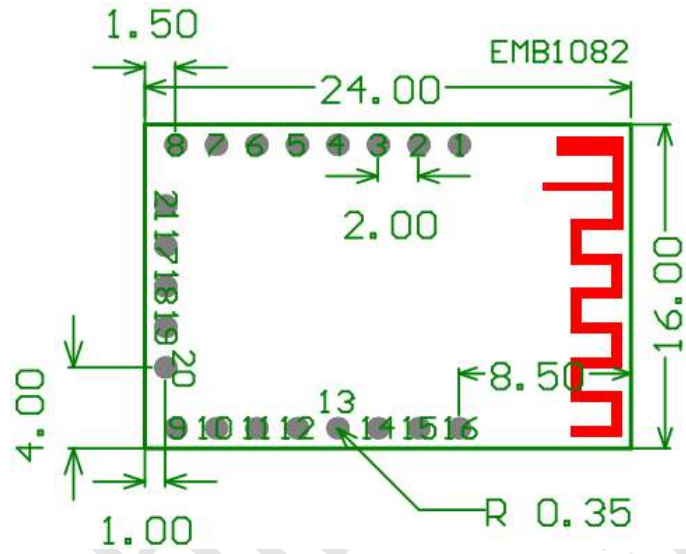

Figure 1 EMB1082 DIP package

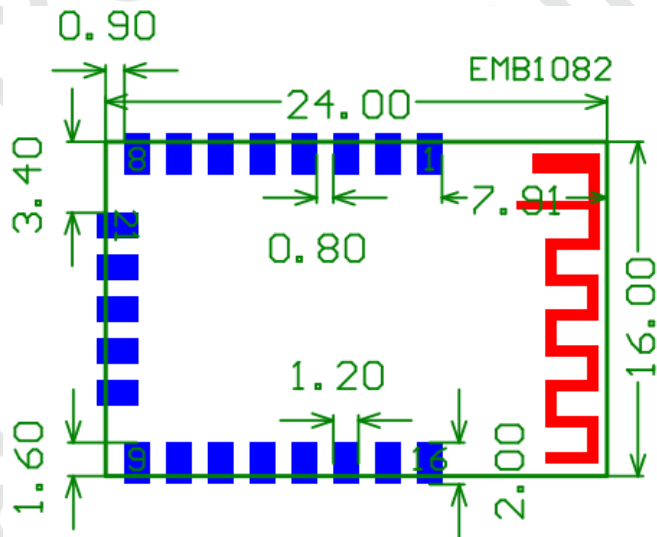

Figure 2 EMB1082 half hole package

2.2 Pin Definition

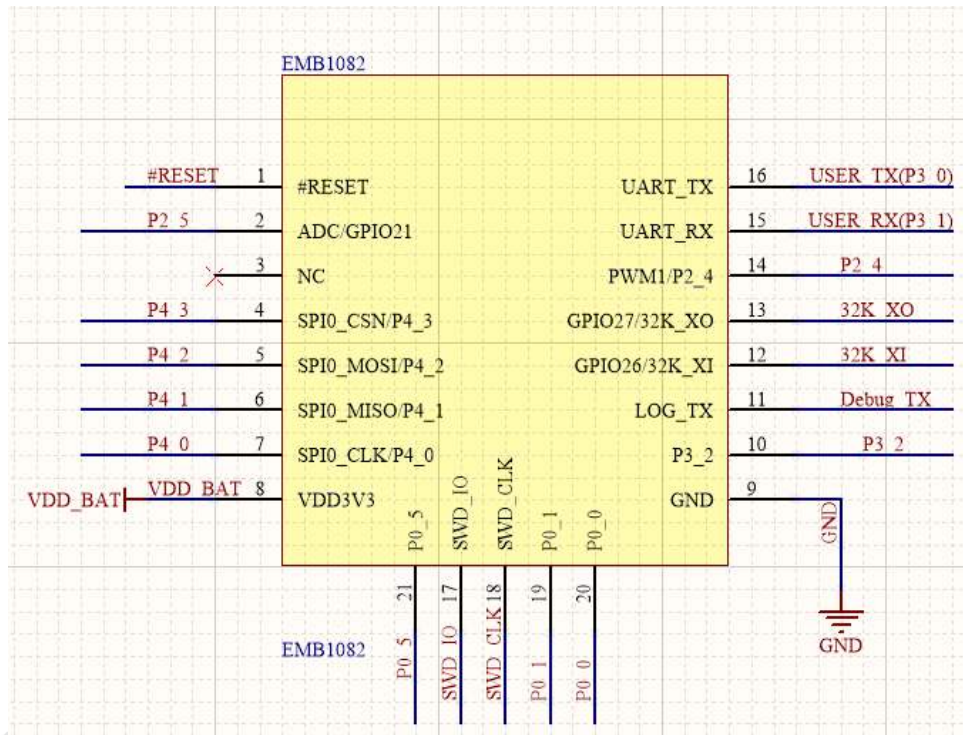

Figure 3 EMB1082 Package Definition

Table 1 EMB1082 Pin Definition

NO.	Name	Type	IO	Note
1	RESET	I		Reset, active low
2	ADC	IO	GPIO21	ADC/PWM/I2C/SPI/UART, max drive current 8mA
3	NC			
4	SPI0_CSN	IO	GPIO31	SPI_CSN/PWM/I2C/SPI/UART, max drive current 8mA
5	SPI0_MOSI	IO	GPIO30	SPI_MOSI/PWM/I2S/SPI/UART, max drive current 8mA
6	SPI0_MISO	IO	GPIO29	SPI_MISO/PWM/I2C/SPI/UART, max drive current 8mA
7	SPI0_CLK	IO	GPIO28	SPI_CLK/PWM/I2C/SPI/UART, max drive current 8mA
8	VDD	S		DC 3.0V
9	GND	S		Ground
10	P3_2	IO	GPIO26	P3_2/PWM/I2C/SPI/UART, max drive current 8mA
11	Debug_TX	IO	GPIO3	Debug log output, can't be used as other function
12	32K_XI	A/IO	GPIO26	32K_XI/PWM/I2C/SPI/UART, max drive current 8mA
13	32K_XO	A/IO	GPIO27	32K_XO/PWM/I2C/SPI/UART, max drive current 8mA
14	PWM1	IO	GPIO20	ADC/PWM/I2C/SPI/UART, max drive current 8mA
15	UART_RX	IO	GPIO25	UART_RX, or FW programming, not recommended to use as other function
16	UART_TX	IO	GPIO24	UART_TX, or FW programming, not

NO.	Name	Type	IO	Note
				recommended to use as other function
17	SWD_IO	IO	GPIO8	FW programming, not recommended to use as other function
18	SWD_CLK	IO	GPIO9	FW programming, not recommended to use as other function
19	P0_1	IO	GPIO1	GPIO/PWM/I2C/SPI/UART, max drive current 8mA
20	P0_0	IO	GPIO0	GPIO/PWM/I2C/SPI/UART, max drive current 8mA
21	P0_5	IO	GPIO5	GPIO/PWM/I2C/SPI/UART, max drive current 8mA

- Type S: power/ground, I/O: GPIO, A: Analog;

- Both UART_TX/RX and SWD can be used for firmware programming. Pull down Debug_TX and then power on the module to enter UART programming mode.

- All the IO pins can be used as other functions.

- SPI data rate: 5MHz

- 400ksps, 12bit, AUXADC

- The register setting of IO pins refer to below table:

表2 引脚复用功能与对应的寄存

0	IDEL	25	reserved	50	SPI0_CLK (master only)	75	KEY_COL_17
1	reserved	26	reserved	51	SPI0_MO (master only)	76	KEY_COL_18
2	reserved	27	UART2_TX	52	SPI0_MI (master only)	77	KEY_COL_19
3	reserved	28	UART2_RX	53	SPI2W_DATA (master only)	78	KEY_ROW_0
4	reserved	29	UART1_TX	54	SPI2W_CLK (master only)	79	KEY_ROW_1
5	I2C0_CLK	30	UART1_RX	55	SPI2W_CS (master only)	80	KEY_ROW_2
6	I2C0_DAT	31	UART1_CTS	56	reserved	81	KEY_ROW_3
7	I2C1_CLK	32	UART1_RTS	57	reserved	82	KEY_ROW_4
8	I2C1_DAT	33	IRDA_TX	58	KEY_COL_0	83	KEY_ROW_5
9	PWM2_P	34	IRDA_RX	59	KEY_COL_1	84	KEY_ROW_6
10	PWM2_N	35	UART0_TX	60	KEY_COL_2	85	KEY_ROW_7
11	PWM3_P	36	UART0_RX	61	KEY_COL_3	86	KEY_ROW_8
12	PWM3_N	37	UART0_CTS	62	KEY_COL_4	87	KEY_ROW_9
13	PWM0	38	UART0_RTS	63	KEY_COL_5	88	KEY_ROW_10
14	PWM1	39	SPI1_SS_N_0 (master only)	64	KEY_COL_6	89	KEY_ROW_11
15	PWM2	40	SPI1_SS_N_1 (master only)	65	KEY_COL_7	90	DWGPIO
16	PWM3	41	SPI1_SS_N_2 (master only)	66	KEY_COL_8	-	-
17	PWM4	42	SPI1_CLK (master only)	67	KEY_COL_9	-	-
18	PWM5	43	SPI1_MO (master only)	68	KEY_COL_10	-	-
19	PWM6	44	SPI1_MI (master only)	69	KEY_COL_11	-	-
20	PWM7	45	SPI0_SS_N_0 (slave)	70	KEY_COL_12	-	-
21	reserved	46	SPI0_CLK (slave)	71	KEY_COL_13	-	-
22	reserved	47	SPI0_SO (slave)	72	KEY_COL_14	-	-
23	reserved	48	SPI0_SI (slave)	73	KEY_COL_15	-	-
24	reserved	49	SPI0_SS_N_0 (master only)	74	KEY_COL_16	-	-

3. Electrical Parameters

3.1 Operating Conditions

EMB1082 would be unstable when input voltage is less than the lowest rated voltage.

Table 2 Range of input voltage

Symbol	Illustration	Condition	Details			
			Minimum	Typ	Maximum	Unit
VDD	Power Supply		2.7	3.0	3.3	V

There would be permanent damage in hardware if the device operates at the voltage over rated value. Meanwhile, reliability could be influenced when the device has a long-term operating at maximum voltage.

Table 3 Absolute maximum voltage rating

Symbol	Description	Minimum	Typ	Unit
VDD	Module input voltage	–	3.3	V
VIN	GPIO input voltage	–	3.6	V

3.2 Power Consumption

Table 4 EMB1082 Power Consumption

Mode	Description	Average	Max
		TA=25°C	TA=25°C
Sleep mode	Wait for 10 minutes to stop broadcasting, and test for 5 minutes	4.7uA	4.8uA
Normal working mode	Connect to Tmall Genie and control it by voice, and test for 5 minutes	14.9mA	15.1mA

Actual working current is variable at different operating mode.

3.3 Working Environment

Table 5 Temperature and humidity condition

Symbol	Name	Maximum	Unit
TSTG	Storage Temperature	-40 to +110	°C
TA	Operation Temperature	-40 to +105	°C
Humidity	Non-condensing, Relative humidity	95	%

3.4 Electrostatic Discharge

Table 6 Electrostatic Discharge Parameters

Symbol	Name	Details	Level	Maximum	Unit
V _{ESD} (HBM)	Electrostatic discharge voltage (Human Body Model)	TA = +25 °C , JESD22-A114	2	2000	V
V _{ESD} (CDM)	Electrostatic discharge voltage (Charged Device Model)	TA = +25 °C , JESD22-C101	II	500	

4. RF parameters

4.1 Basic RF parameters

Table 7 Radio-frequency standards

Name	Illustration
Working frequency	2.4GHz ISM band
Wi-Fi wireless standard	Bluetooth5.0
Modulation	GFSK
Data rate	1Mbps
Antenna type	PCB (Default) IPEX Connector (Optional)

4.2 GFSK Parameters

Table 8 GFSK mode parameters

Item	Notes
Modulation	GFSK
Frequency range	2.400GHz-2.4835GHz ISM band
Data rate	1Mbps

Table 9 GFSK mode RX parameters

RX parameter	Min	Typ.	Max	Unit
Sensitivity	-97	-96	-95	dBm
Frequency error	-10		+10	KHz

Table 10 GFSK TX parameters

test item	datarate	BT Spec			Measurement			Channel Frequency		
		Min	Typical	Max	Max	Average	Min	CH0 (2402MHz)	CH19 (2440MHz)	CH39 (2480MHz)
输出功率 (POWER_AVERAGE)	LE	-20	6.5	7.5	6.49		6.18	6.18	6.49	6.31
初始载波频率容许量 (Frequency Drift Error)	LE	-50KHz		50KHz	2.501		-3.055	1.398	2.501	-3.055
Carrier frequency offset and drift at NOC:	在正常操作模式下的载波频率偏移和漂移									
Fn max	LE	-150KHz		150KHz	4.858		2.872	2.872	4.858	4.007
F0-Fn	LE			50KHz	4.394		2.636	2.636	4.394	3.707
F1-F0	LE			20KHz	2.339		0.313	0.313	2.339	0.648
Fn-F(n-5) n=6,7,8...k	LE			20KHz	3.547		2.335	2.335	3.337	3.547
Modulation characteristics:	调制特性									
ΔF1avg	LE	225KHz		275KHz	249.489		242.04	248.111	242.043	249.489
ΔF2avg	LE	185KHz		275KHz	248.284		231.35	241.481	231.353	248.284
ΔF2avg/ΔF1avg	LE	0.8			0.99517		0.9558	0.9732781	0.9558343	0.995170128

带内杂散测试:

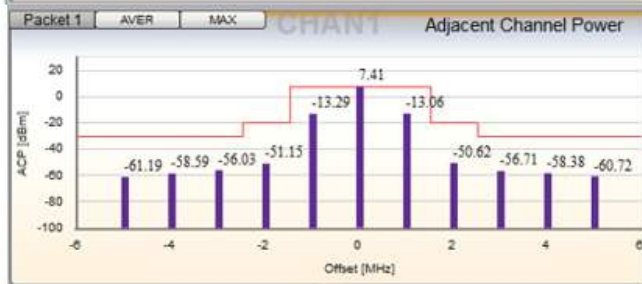
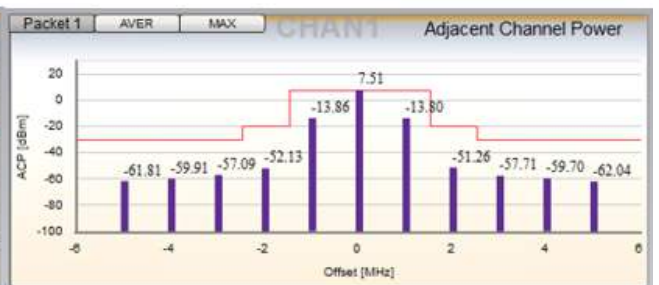

5. Antenna Information

5.1 Antenna Type

EMB1082 has two types of antenna: PCB antenna (EMB1082-P), IPEX connector (EMB1082-E).

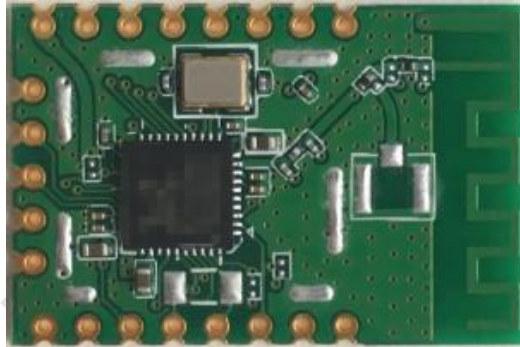

Figure 5 EMB1082-P



Figure 6 EMB1082-E

5.2 PCB Antenna Clearance Zone

Main PCB should have a distance over 16mm with other metal elements when using PCB antenna in Wi-Fi device. Shadow parts in the figure below should keep away from metal elements, sensor, interference source and other material that could cause signal interference.

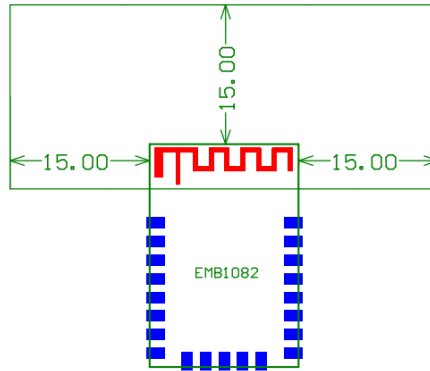

Figure 4 Minimum Clearance Zone of PCB Antenna (Unit: mm)

5.3 External Antenna Connector

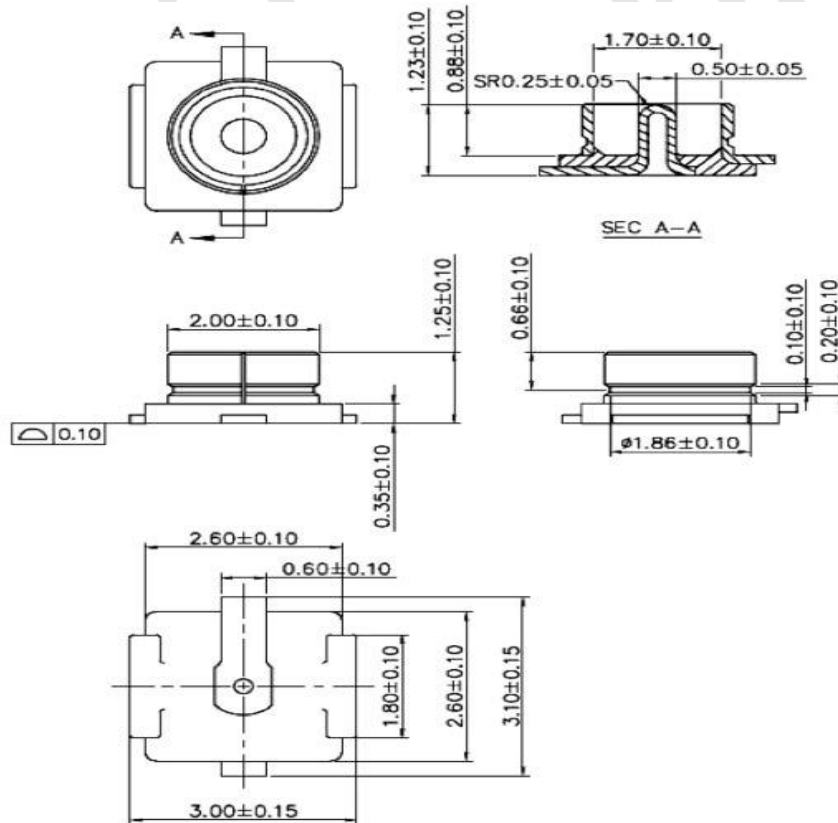

Figure 5 Size of External Antenna Connector

6. Assembly Information and Production Guidance

6.1 Assembly Size

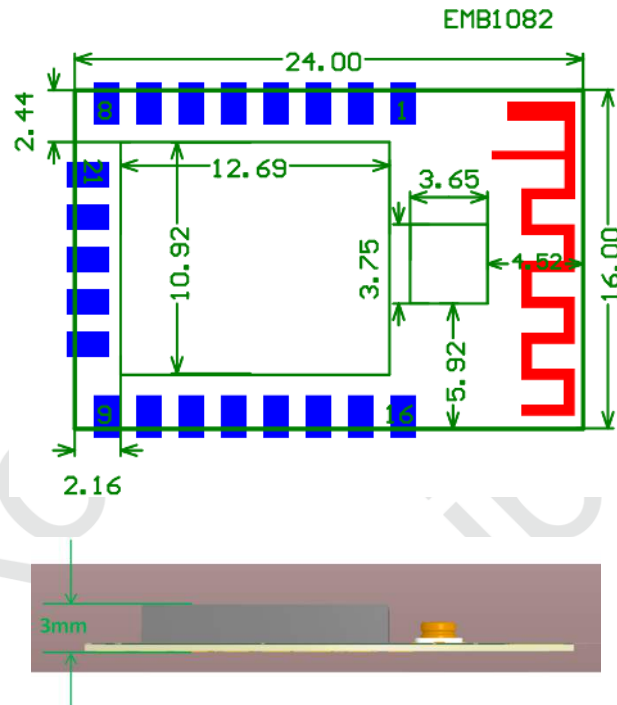

Figure 6 EWB1082 mechanical size (Unit: mm)

6.2 Production Guidance (Important)

- The stamp hole package module produced by Mxchip must completely being patched by SMT machine in 24 hours after open firmware package. Otherwise the module should be re-package by vacuum pumping and drying before patch.
 - Devices for SMT patch:
 - (1) Reflow soldering machine
 - (2) AOI detector
 - (3) Suction nozzle with 6-8mm caliber
 - Device for drying:
 - (1) Cabinet type oven
 - (2) Anti-static and high thermos tolerant tray
 - (3) Anti-static and high thermos tolerant gloves
- Conditions of product storage (Storage environment is shown in figure 8):

- Moisture bag must be stored in temperature below 30 and humidity less than 85%RH.
- Dry packaging products, the guarantee period should be from 6 months date of packing seal.
- Humidity indicator card is in the hermetic package.



Figure 7 Humidity Card

- Humidity indicator card and drying situation:
 - 2 hours drying for module if the color ring at 30%, 40%, 50% in humidity indicator card is blue after unpacking;
 - 4 hours drying for module if the color ring at 30% in humidity indicator card is pink after unpacking;
 - 6 hours drying for module if the color ring at 30%, 40% in humidity indicator card is pink after unpacking;
 - 12 hours drying for module if the color ring at 30%, 40%, 50% in humidity indicator card is pink after unpacking.
- Drying parameters:
 - Drying temperature: $125^{\circ}\text{C} \pm 5^{\circ}\text{C}$;
 - Alarm temperature: 130°C ;
 - SMT patch when the device cool down below 36°C in natural condition;
 - Dry times: 1;
 - Please dry again if the module is unsoldering in 12 hours after last drying.
- SMT is unsuitable if the module packed over 3 months. There would be serious oxidation of the pad because of immersion gold and cause false welding and lack of weld. Mxchip does not assume the corresponding responsibility;
- ESD protection is required before SMT;
- SMT patch should on the basis of reflow profile diagram, maximum temperature 245°C , reflow profile diagram is shown in figure 10;

- In order to guarantee the reflow soldering qualification rate, vision and AOI detection should be done in 10% products for the first patch to make sure the rationality of temperature control, device adsorption mode and position. Detect 5 to 10 sample every hour in the following batch production.

6.3 Considerations

- Operator should wear anti-static gloves during producing;
- No more than drying time;
- Any explosive, flammable and corrosive material is not allowed to add in drying;
- Module should be put into oven with high thermotolerant tray. Ventilation should exist between each module and no direct contact with oven;
- Make sure oven is closed when drying to prevent temperature leaking;
- Reduce opening time or keep closing the door of the oven during drying;
- Use anti-static glove to take out module when its temperature below 36°C by natural cool down after drying;
- Make sure no water and dirt in the bottom of the module;
- Temperature and humidity control is level 3 for initial modules. Storage and drying conditions are based on IPC/JEDEC J-STD-020.

6.4 Storage Condition

	CAUTION This bag contains MOISTURE-SENSITIVE DEVICES	LEVEL <div style="border: 1px solid black; padding: 5px; display: inline-block;"> 3 </div>
	If Blank, see adjacent bar code label	
<p>1. Calculated shelf life in sealed bag: 12 months at < 40°C and < 90% relative humidity (RH)</p>		
<p>2. Peak package body temperature: _____ 260 _____ °C <small>If Blank, see adjacent bar code label</small></p>		
<p>3. After bag is opened, devices that will be subjected to reflow solder or other high temperature process must</p> <p>a) Mounted within: _____ 168 _____ hrs. of factory conditions <small>If Blank, see adjacent bar code label</small></p> <p style="margin-left: 40px;">≤ 30°C/60%RH, OR</p> <p>b) Stored at <10% RH</p>		
<p>4. Devices require bake, before mounting, if:</p> <p>a) Humidity Indicator Card is > 10% when read at 23 ± 5°C</p> <p>b) 3a or 3b not met.</p>		
<p>5. If baking is required, devices may be baked for 48 hrs. at 125 ± 5°C</p>		
<p>Note: If device containers cannot be subjected to high temperature or shorter bake times are desired, reference IPC/JEDEC J-STD-033 for bake procedure</p>		
<p>Bag Seal Date: _____ <small>If Blank, see adjacent bar code label</small></p>		
<p>Note: Level and body temperature defined by IPC/JEDEC J-STD-020</p>		

Figure 8 Storage Condition

6.5 Temperature Curve of Secondary Reflow

Suggested solder paste type: SAC305, unleaded, solder paste thickness from 0.12 to 0.15, less than 2 times reflow.

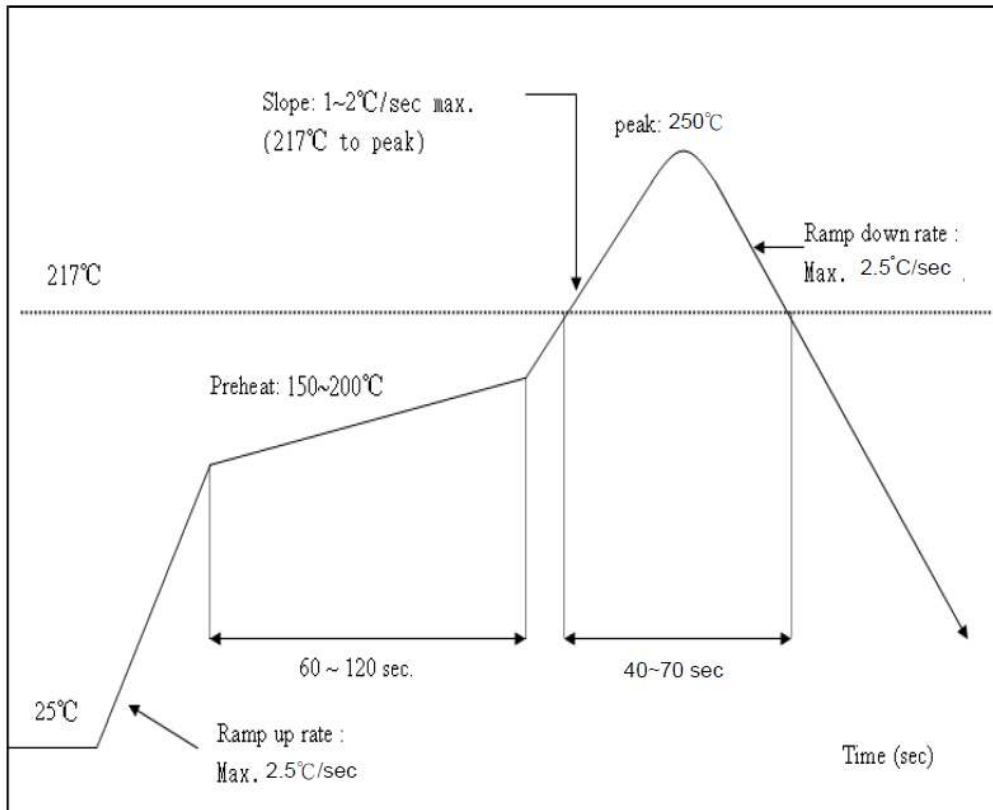
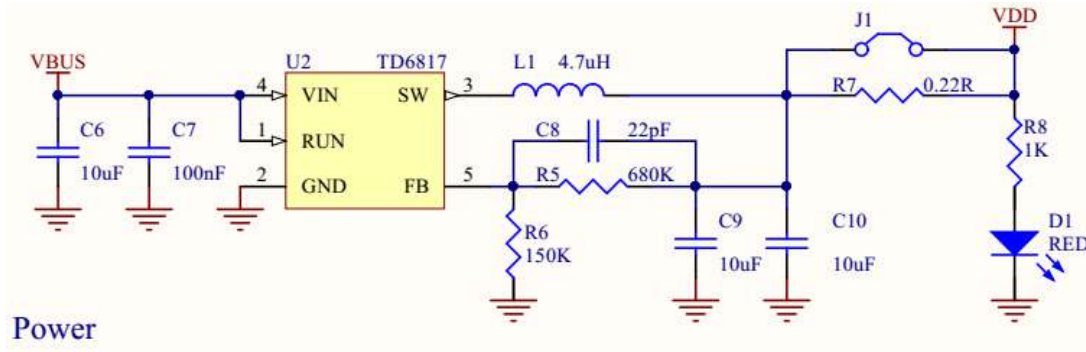

Figure 9 Temperature Curve of Secondary Reflow

7. Reference Circuit

Power source circuit is shown in figure 11, USB to UART is shown in figure 12, external interface circuit is shown in figure 13.



Power

Figure 10 Power Source Circuit

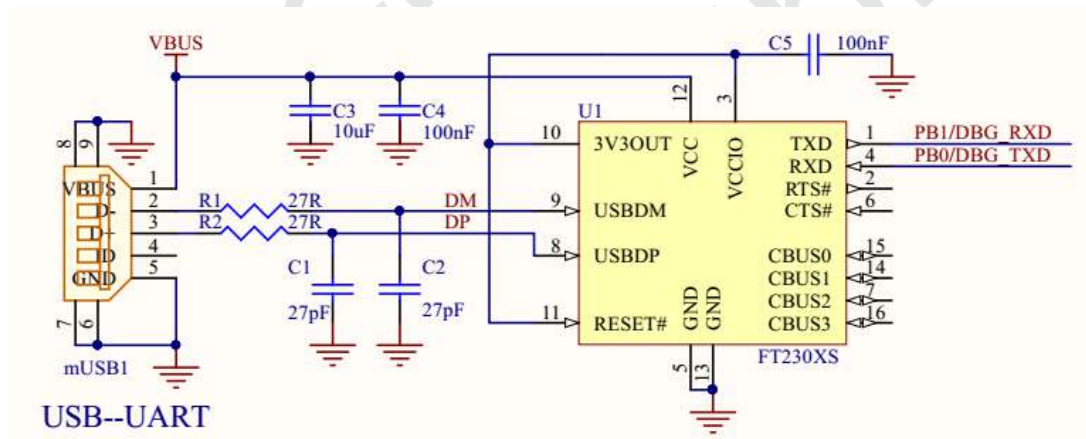

USB--UART

Figure 11 USB to UART

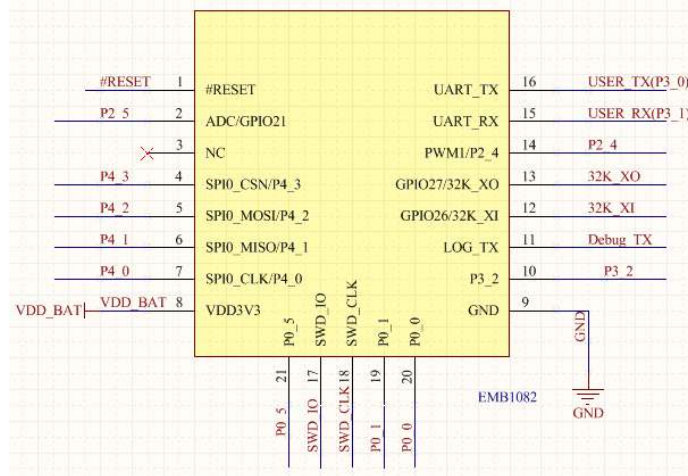

Figure 12 External Interface Circuit of EMB1082

Voltage of EMB1082 UART is 3.3V. 5V UART should convert to 3.3V UART for the users that have 5V chips. Convert circuit is shown in figure 14.

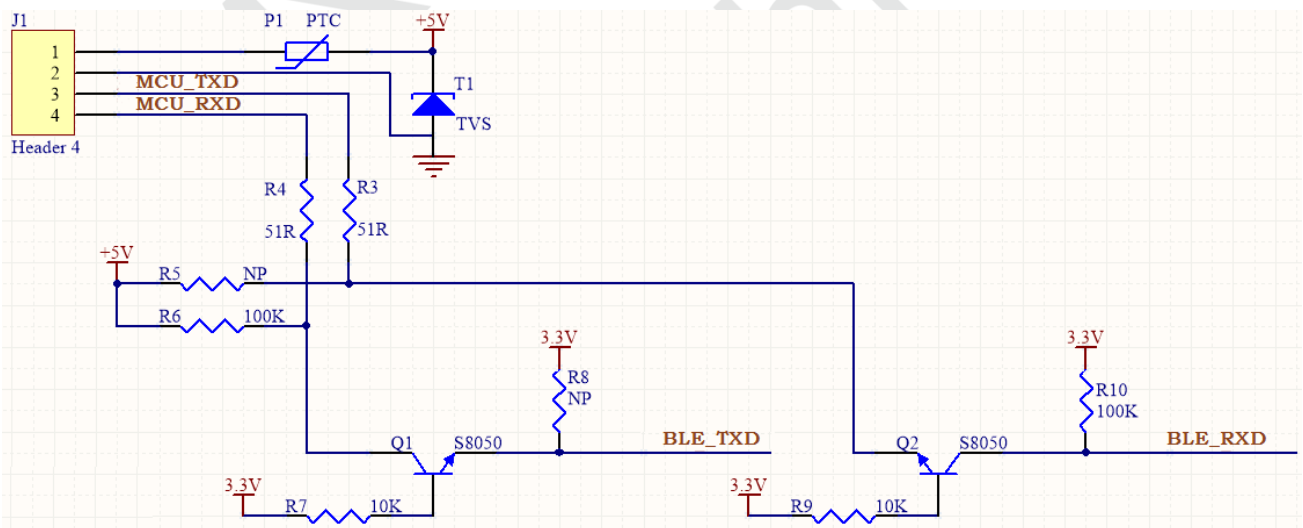

Figure 13 3.3V UART- 5V UART Convert Circuit

8. Module MOQ and Package Information

Table 16 Module MOQ and Package Information

PN	MOQ(pcs)	Package type
EMW1082-P EMW1082-E	2240	Tray

9. Sales Information and Technical Support

For consultation or purchase the product, please contact Mxchip during working hours:

From Monday to Friday, morning 9:00~12:00, afternoon 13:00~18:00

Telephone: +86-21-52655026

Contact address: 9thFloor, No.5, Lane2145 JinshaJiang Road Putuo District, ShangHai.

Postcode: 200333

Email: sales@mxchip.com

Mxchip
reprint prohibited