

FEATURES:

- Advanced CMOS Technology
- Guaranteed low skew < 200ps (max.)
- Very low propagation delay < 2.5ns (max)
- Very low duty cycle distortion < 270ps (max)
- Very low CMOS power levels
- Operating frequency up to 166MHz
- TTL compatible inputs and outputs
- Inputs can be driven from 3.3V or 5V components
- Two independent output banks with 3-state control
- 1:5 fanout per bank
- "Heartbeat" monitor output
- $V_{CC} = 3.3V \pm 0.3V$
- Available in SSOP and QSOP packages

DESCRIPTION:

The FCT3805 is a 3.3 volt clock driver built using advanced CMOS technology. The device consists of two banks of drivers, each with a 1:5 fanout and its own output enable control. The device has a "heartbeat" monitor for diagnostics and PLL driving. The MON output is identical to all other outputs and complies with the output specifications in this document. The FCT3805 offers low capacitance inputs.

The FCT3805 is designed for high speed clock distribution where signal quality and skew are critical. The FCT3805 also allows single point-to-point transmission line driving in applications such as address distribution, where one signal must be distributed to multiple receivers with low skew and high signal quality.

For more information on using the FCT3805 with two different input frequencies on bank A and B, please see AN-236.

FUNCTIONAL BLOCK DIAGRAM

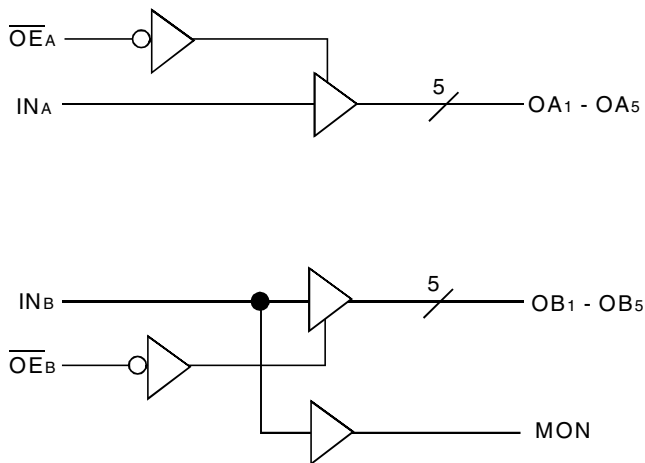

PIN CONFIGURATION

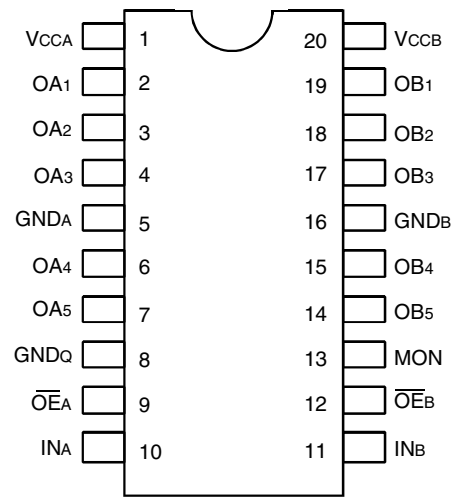

SSOP/ QSOP  
TOP VIEW

## ABSOLUTE MAXIMUM RATINGS<sup>(1)</sup>

Symbol	Description	Max	Unit
V <sub>CC</sub>	Input Power Supply Voltage	-0.5 to +4.6	V
V <sub>I</sub>	Input Voltage	-0.5 to +5.5	V
V <sub>O</sub>	Output Voltage	-0.5 to V <sub>CC</sub> +0.5	V
T <sub>J</sub>	Junction Temperature	150	°C
T <sub>STG</sub>	Storage Temperature	-65 to +165	°C

NOTE:

- Stresses greater than those listed under ABSOLUTE MAXIMUM RATINGS may cause permanent damage to the device. This is a stress rating only and functional operation of the device at these or any other conditions above those indicated in the operational sections of this specification is not implied. Exposure to absolute maximum rating conditions for extended periods may affect reliability.

## PIN DESCRIPTION

Pin Names	Description
OEA, OEB	3-State Output Enable Inputs (Active LOW)
INA, INB	Clock Inputs
OAn, OBn	Clock Outputs
MON	Monitor Output

## FUNCTION TABLE (1)

Inputs		Outputs	
OEA, OEB	INA, INB	OAn, OBn	MON
L	L	L	L
L	H	H	H
H	L	Z	L
H	H	Z	H

NOTE:

- H = HIGH  
L = LOW  
Z = High-Impedance

## CAPACITANCE (T<sub>A</sub> = +25°C, f = 1.0MHz)

Symbol	Parameter <sup>(1)</sup>	Conditions	Typ.	Max.	Unit
C <sub>IN</sub>	Input Capacitance	V <sub>IN</sub> = 0V	3	4	pF
C <sub>OUT</sub>	Output Capacitance	V <sub>OUT</sub> = 0V	—	6	pF

NOTE:

- This parameter is measured at characterization but not tested.

## DC ELECTRICAL CHARACTERISTICS OVER OPERATING RANGE

Following Conditions Apply Unless Otherwise Specified

Industrial: T<sub>A</sub> = -40°C to +85°C, V<sub>CC</sub> = 3.3V ± 0.3V

Symbol	Parameter	Test Conditions <sup>(1)</sup>		Min.	Typ. <sup>(2)</sup>	Max.	Unit
V <sub>IH</sub>	Input HIGH Level			2	—	5.5	V
V <sub>IL</sub>	Input LOW Level			-0.5	—	0.8	V
I <sub>IH</sub>	Input HIGH Current	V <sub>CC</sub> = Max.	V <sub>I</sub> = 5.5V	—	—	±1	μA
I <sub>IL</sub>	Input LOW Current	V <sub>CC</sub> = Max.	V <sub>I</sub> = GND	—	—	±1	
I <sub>OZH</sub> I <sub>OZL</sub>	High Impedance Output Current (3-State Outputs Pins)	V <sub>CC</sub> = Max.	V <sub>O</sub> = V <sub>CC</sub> V <sub>O</sub> = GND	—	—	±1 ±1	
V <sub>IK</sub>	Clamp Diode Voltage	V <sub>CC</sub> = Min., I <sub>IN</sub> = -18mA		—	-0.7	-1.2	V
I <sub>ODH</sub>	Output HIGH Current	V <sub>CC</sub> = 3.3V, V <sub>IN</sub> = V <sub>IH</sub> or V <sub>IL</sub> , V <sub>O</sub> = 1.5V <sup>(3,4)</sup>		-45	-74	-180	mA
I <sub>ODL</sub>	Output LOW Current	V <sub>CC</sub> = 3.3V, V <sub>IN</sub> = V <sub>IH</sub> or V <sub>IL</sub> , V <sub>O</sub> = 1.5V <sup>(3,4)</sup>		50	90	200	mA
I <sub>OS</sub>	Short Circuit Current	V <sub>CC</sub> = Max., V <sub>O</sub> = GND <sup>(3,4)</sup>		-60	-135	-240	mA
V <sub>OH</sub>	Output HIGH Voltage	V <sub>CC</sub> = Min. V <sub>IN</sub> = V <sub>IH</sub> or V <sub>IL</sub>	I <sub>OH</sub> = -12mA	2.4 <sup>(5)</sup>	3	—	V
			I <sub>OH</sub> = -8mA	2.4 <sup>(5)</sup>	3	—	
			I <sub>OH</sub> = -100μA	V <sub>CC</sub> - 0.2	—	—	
V <sub>OL</sub>	Output LOW Voltage	V <sub>CC</sub> = Min. V <sub>IN</sub> = V <sub>IH</sub> or V <sub>IL</sub>	I <sub>OL</sub> = 12mA	—	0.3	0.4	V
			I <sub>OL</sub> = 8mA	—	0.2	0.4	
			I <sub>OL</sub> = 100μA	—	—	0.2	

NOTES:

- For conditions shown as Max. or Min., use appropriate value specified under Electrical Characteristics for the applicable device type.
- Typical values are at V<sub>CC</sub> = 3.3V, 25°C ambient.
- Not more than one output should be shorted at one time. Duration of the test should not exceed one second.
- This parameter is guaranteed but not tested.
- V<sub>OH</sub> = V<sub>CC</sub> - 0.6V at rated current.

## POWER SUPPLY CHARACTERISTICS

Symbol	Parameter	Test Conditions <sup>(1)</sup>		Min.	Typ. <sup>(2)</sup>	Max.	Unit
I <sub>CC</sub> I <sub>CC</sub> H I <sub>CC</sub> Z	Quiescent Power Supply Current	V <sub>CC</sub> = Max. V <sub>IN</sub> = GND or V <sub>CC</sub>		—	0.1	30	μA
ΔI <sub>CC</sub>	Power Supply Current per Input HIGH	V <sub>CC</sub> = Max. V <sub>IN</sub> = V <sub>CC</sub> - 0.6V		—	45	300	μA
I <sub>CCD</sub>	Dynamic Power Supply Current per Output <sup>(3)</sup>	V <sub>CC</sub> = Max. C <sub>L</sub> = 15pF All Outputs Toggling	V <sub>IN</sub> = V <sub>CC</sub> V <sub>IN</sub> = GND	—	80	120	μA/MHz
I <sub>C</sub>	Total Power Supply Current <sup>(4)</sup>	V <sub>CC</sub> = Max. C <sub>L</sub> = 15pF All Outputs Toggling f <sub>i</sub> = 133MHz	V <sub>IN</sub> = V <sub>CC</sub> V <sub>IN</sub> = GND	—	125	150	mA
			V <sub>IN</sub> = V <sub>CC</sub> - 0.6V V <sub>IN</sub> = GND	—	125	150	
		V <sub>CC</sub> = Max. C <sub>L</sub> = 15pF All Outputs Toggling f <sub>i</sub> = 166MHz	V <sub>IN</sub> = V <sub>CC</sub> V <sub>IN</sub> = GND	—	155	195	
			V <sub>IN</sub> = V <sub>CC</sub> - 0.6V V <sub>IN</sub> = GND	—	160	195	

### NOTES:

1. For conditions shown as Max. or Min., use appropriate value specified under Electrical Characteristics for the applicable device type.

2. Typical values are at V<sub>CC</sub> = 3.3V, +25°C ambient.

3. This parameter is not directly testable, but is derived for use in Total Power Supply calculations.

4. I<sub>C</sub> = I<sub>QUIESCENT</sub> + I<sub>INPUTS</sub> + I<sub>DYNAMIC</sub>

$$I_C = I_{CC} + \Delta I_{CC} \cdot D_H \cdot N_T + I_{CCD} \cdot (f_o \cdot N_o)$$

I<sub>CC</sub> = Quiescent Current (I<sub>CC</sub>L, I<sub>CC</sub>H and I<sub>CC</sub>Z)

ΔI<sub>CC</sub> = Power Supply Current for a TTL High Input (V<sub>IN</sub> = V<sub>CC</sub> - 0.6V)

D<sub>H</sub> = Duty Cycle for TTL Inputs High

N<sub>T</sub> = Number of TTL Inputs at D<sub>H</sub>

I<sub>CCD</sub> = Dynamic Current Caused by an Input Transition Pair (HLH or LHL)

f<sub>o</sub> = Output Frequency

N<sub>o</sub> = Number of Outputs at f<sub>o</sub>

### SWITCHING CHARACTERISTICS OVER OPERATING RANGE - 3805D (3,4)

Symbol	Parameter	Conditions <sup>(1)</sup>	Min. <sup>(2)</sup>	Max.	Unit
t <sub>PLH</sub>	Propagation Delay	CL = 15pF f ≤ 133MHz	1	3	ns
t <sub>PHL</sub>	INA to OAn, INb to OBn				
t <sub>R</sub>	Output Rise Time (0.8V to 2V)		—	1.5	ns
t <sub>F</sub>	Output Fall Time (2V to 0.8V)		—	1.5	ns
t <sub>SK(O)</sub>	Same device output pin to pin skew <sup>(5)</sup>		—	270	ps
t <sub>SK(P)</sub>	Pulse skew <sup>(6,9)</sup>		—	270	ps
t <sub>SK(PP)</sub>	Part to part skew <sup>(7)</sup>		—	550	ps
t <sub>PZL</sub>	Output Enable Time		—	5.2	ns
t <sub>PZH</sub>	OEA to OAn, OEB to OBn				
t <sub>PLZ</sub>	Output Disable Time		—	5.2	ns
t <sub>PHZ</sub>	OEA to OAn, OEB to OBn				
f <sub>MAX</sub>	Input Frequency		—	133	MHz

### SWITCHING CHARACTERISTICS OVER OPERATING RANGE - 3805E (3,4)

Symbol	Parameter	Conditions <sup>(1,8)</sup>	Min. <sup>(2)</sup>	Max.	Unit
t <sub>PLH</sub>	Propagation Delay	CL = 15pF f ≤ 166MHz	0.5	2.5	ns
t <sub>PHL</sub>	INA to OAn, INb to OBn				
t <sub>R</sub>	Output Rise Time (0.8V to 2V)		—	1	ns
t <sub>F</sub>	Output Fall Time (2V to 0.8V)		—	1	ns
t <sub>SK(O)</sub>	Same device output pin to pin skew <sup>(5)</sup>		—	200	ps
t <sub>SK(P)</sub>	Pulse skew <sup>(6,9)</sup>		—	270	ps
t <sub>SK(PP)</sub>	Part to part skew <sup>(7)</sup>		—	550	ps
t <sub>PZL</sub>	Output Enable Time		—	5.2	ns
t <sub>PZH</sub>	OEA to OAn, OEB to OBn				
t <sub>PLZ</sub>	Output Disable Time		—	5.2	ns
t <sub>PHZ</sub>	OEA to OAn, OEB to OBn				
f <sub>MAX</sub>	Input Frequency		—	166	MHz

NOTES:

1. See test circuits and waveforms.
2. Minimum limits are guaranteed but not tested on Propagation Delays.
3. t<sub>PLH</sub>, t<sub>PHL</sub>, t<sub>SK(P)</sub>, and t<sub>SK(O)</sub> are production tested. All other parameters guaranteed but not production tested.
4. Propagation delay range indicated by Min. and Max. limit is due to V<sub>CC</sub>, operating temperature and process parameters. These propagation delay limits do not imply skew.
5. Skew measured between all outputs under identical transitions and load conditions.
6. Skew measured is difference between propagation delay times t<sub>PHL</sub> and t<sub>PLH</sub> of same outputs under identical load conditions.
7. Part to part skew for all outputs given identical transitions and load conditions at identical V<sub>CC</sub> levels and temperature.
8. Airflow of 1m/s is recommended for frequencies above 133MHz.
9. This parameter is measured using f = 1MHz.

## TEST CIRCUITS AND WAVEFORMS

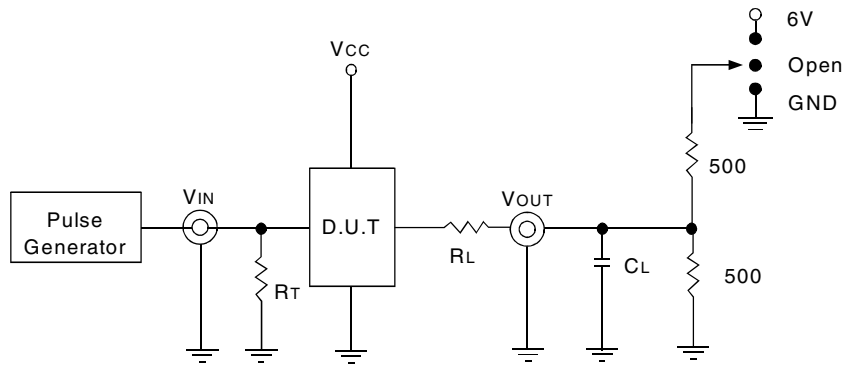

Enable and Disable Time Circuit

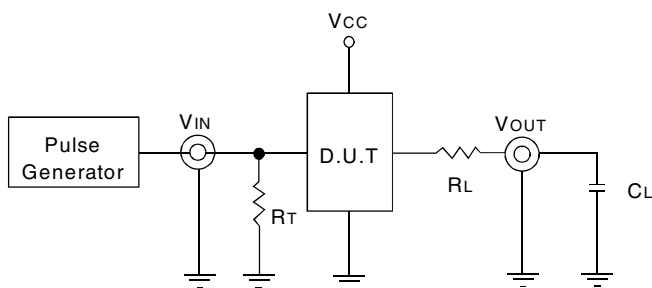

CL = 15pF Test Circuit

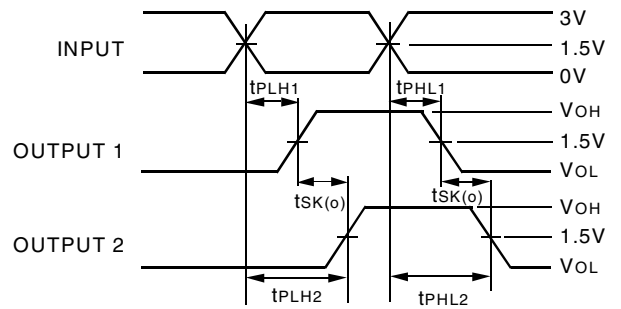

$$t_{SK(O)} = |t_{PLH2} - t_{PLH1}| \text{ or } |t_{PHL2} - t_{PHL1}|$$

Output Skew - tSK(O)

## SWITCH POSITION

Test	Switch
Disable Low Enable Low	6V
Disable High Enable High	GND

## TEST CONDITIONS

Symbol	VCC = 3.3V ±0.3V	Unit
CL	15	pF
RT	ZOUT of pulse generator	Ω
RL	33	Ω
tr / tf	1 (0V to 3V or 3V to 0V)	ns

### DEFINITIONS:

CL = Load capacitance: includes jig and probe capacitance.

RT = Termination resistance: should be equal to ZOUT of the Pulse Generator.

tr / tf = Rise/Fall time of the input stimulus from the Pulse Generator.

## TEST CIRCUITS AND WAVEFORMS

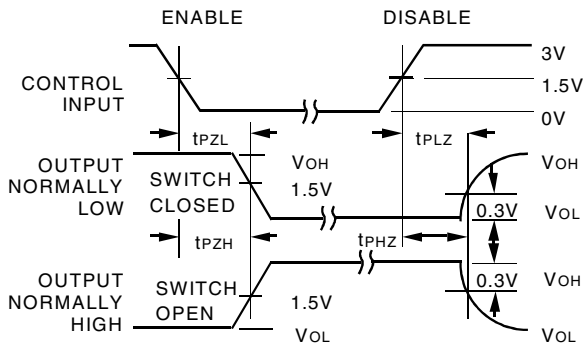

Enable and Disable Times

**NOTE:**

1. Diagram shown for input Control Enable-LOW and input Control Disable-HIGH

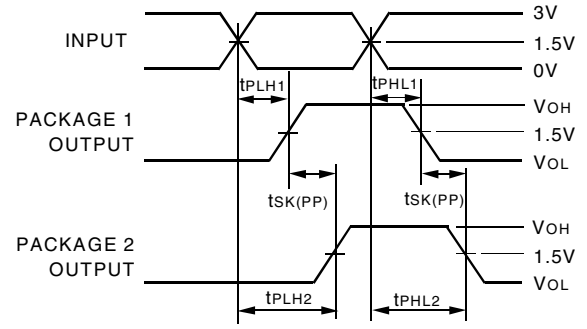

$$tsk(PP) = |tPLH2 - tPLH1| \text{ or } |tPHL2 - tPHL1|$$

Part-to-Part Skew -  $tsk(PP)$

Part-to-Part Skew is for the same package and speed grade.

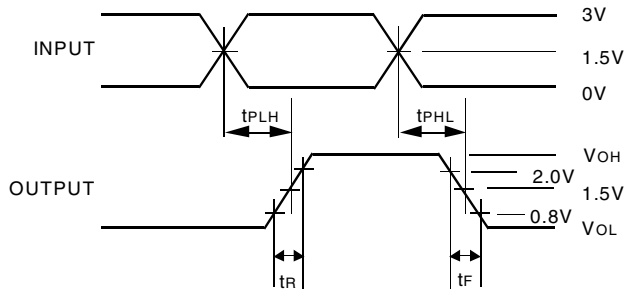

Propagation Delay

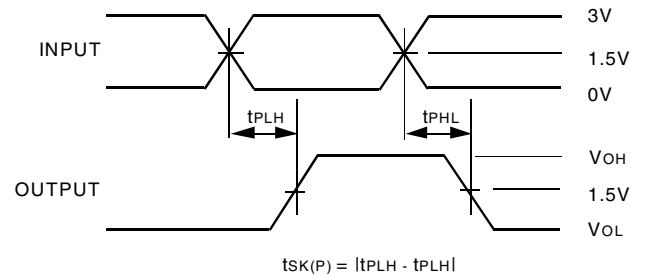

Pulse Skew

### ORDERING INFORMATION

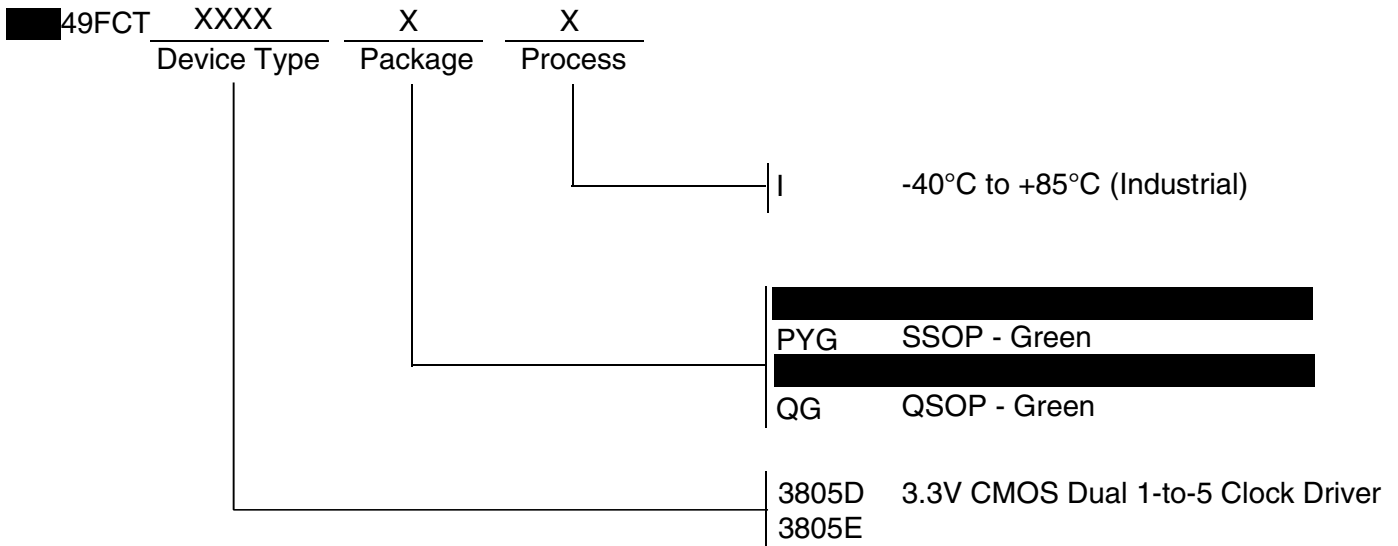

## IMPORTANT NOTICE AND DISCLAIMER

RENESAS ELECTRONICS CORPORATION AND ITS SUBSIDIARIES (“RENESAS”) PROVIDES TECHNICAL SPECIFICATIONS AND RELIABILITY DATA (INCLUDING DATASHEETS), DESIGN RESOURCES (INCLUDING REFERENCE DESIGNS), APPLICATION OR OTHER DESIGN ADVICE, WEB TOOLS, SAFETY INFORMATION, AND OTHER RESOURCES “AS IS” AND WITH ALL FAULTS, AND DISCLAIMS ALL WARRANTIES, EXPRESS OR IMPLIED, INCLUDING, WITHOUT LIMITATION, ANY IMPLIED WARRANTIES OF MERCHANTABILITY, FITNESS FOR A PARTICULAR PURPOSE, OR NON-INFRINGEMENT OF THIRD PARTY INTELLECTUAL PROPERTY RIGHTS.

These resources are intended for developers skilled in the art designing with Renesas products. You are solely responsible for (1) selecting the appropriate products for your application, (2) designing, validating, and testing your application, and (3) ensuring your application meets applicable standards, and any other safety, security, or other requirements. These resources are subject to change without notice. Renesas grants you permission to use these resources only for development of an application that uses Renesas products. Other reproduction or use of these resources is strictly prohibited. No license is granted to any other Renesas intellectual property or to any third party intellectual property. Renesas disclaims responsibility for, and you will fully indemnify Renesas and its representatives against, any claims, damages, costs, losses, or liabilities arising out of your use of these resources. Renesas' products are provided only subject to Renesas' Terms and Conditions of Sale or other applicable terms agreed to in writing. No use of any Renesas resources expands or otherwise alters any applicable warranties or warranty disclaimers for these products.

(Disclaimer Rev.1.0 Mar 2020)

### Corporate Headquarters

TOYOSU FORESIA, 3-2-24 Toyosu,  
Koto-ku, Tokyo 135-0061, Japan  
[www.renesas.com](http://www.renesas.com)

### Contact Information

For further information on a product, technology, the most up-to-date version of a document, or your nearest sales office, please visit:  
[www.renesas.com/contact/](http://www.renesas.com/contact/)

### Trademarks

Renesas and the Renesas logo are trademarks of Renesas Electronics Corporation. All trademarks and registered trademarks are the property of their respective owners.