

# Board Level Heat Sinks

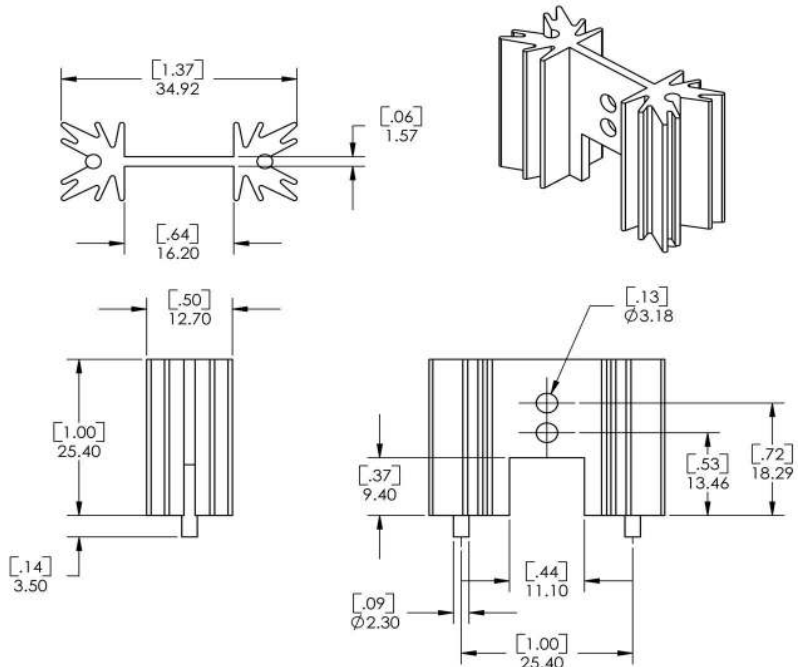

ThermaFlo

P/N: 411910B02500

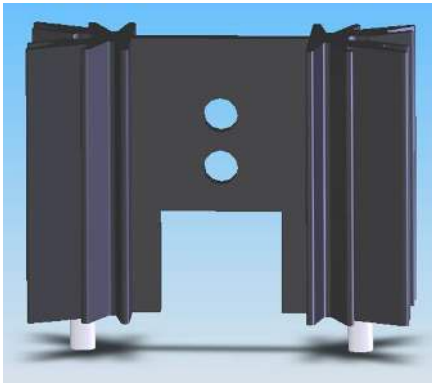

## PRODUCT SPECIFICATIONS

- Devices: TO-202 & TO-220
- Size: 12.7 x 34.9 x 25.4 mm
- Material: Aluminum
- Weight: 10.4 g
- Type: Extruded
- Finish: Black Anodized
- PCB Mounting: Solderable Pins
- Package: Bulk
- Accessories: Hardware & Thermal Interface Material

## FEATURES & BENEFITS

- Multiple Holes for Device Attachment
- Dual Device Cooling Heat Sink
- Vertical Mounting via Solderable Pins
- RoHS Compliant



## CUSTOMIZED HEATSINKS

- Specialized Plating
- Specialized Body Configurations
- Contact Applications Engineering

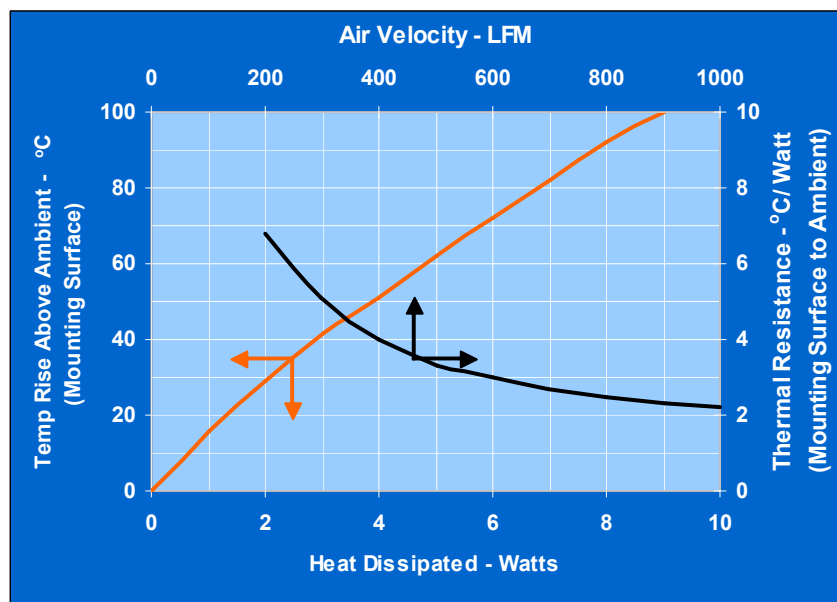

TO-202 & TO-220

**COMAIR ROTRON, INC**  
 8929 Terman Court, San Diego, CA 92121  
 Ph (858) 348-6200 Fax (858) 566-4577  
 E-mail: sales@comairrotron.com,  
 Web: www.comairrotron.com