

ASSR-1410, ASSR-1411, and ASSR-1420

General-Purpose, Form A, Solid State Relay (Photo MOSFET) (60V/0.6A/1Ω)

Description

The Broadcom[®] ASSR-14XX Series consists of an AlGaAs infrared light-emitting diode (LED) input stage that is optically coupled to a high-voltage output detector circuit. The detector consists of a high-speed photovoltaic diode array and driver circuitry to switch on/off two discrete high-voltage MOSFETs. The relay turns on (contact closes) with a minimum input current of 3 mA through the input LED. The relay turns off (contact opens) with an input voltage of 0.8V or less.

The single-channel configurations, ASSR-1410 and ASSR-1411, are equivalent to 1 Form A Electromechanical Relays (EMR), and the dual-channel configuration, ASSR-1420, is equivalent to 2 Form A EMR. They are available in 4-pin SO, 6-pin DIP, 8-pin DIP, and gull wing surface mount for DIP packages. Their electrical and switching characteristics are specified over the temperature range of -40°C to $+85^{\circ}\text{C}$. They are used for general-purpose switching of signals and low-power AC/DC loads.

ASSR-1411 enables AC/DC and DC-only output connections. For DC-only connection, the output current, I_{O} , increases to 1.2A and the on-resistance, $R_{(\text{ON})}$, reduces to 0.5Ω.

CAUTION! It is advised that normal static precautions be taken in the handling and assembly of this component to prevent damage and degradation that may be induced by ESD. The components featured in this data sheet are not to be used in military or aerospace applications or environments. The components are not AEC-Q100 qualified and are not recommended for automotive applications.

Features

- Compact solid-state bidirectional signal switch
- Single- and dual-channel normally-off Single-Pole-Single-Throw (SPST) relay
- 60V output withstand voltage
- 0.6A or 1.2A current rating (See the schematics for ASSR-1411 connections A and B.)
- Low input current: CMOS compatibility
- Low on-resistance:
 - 0.2Ω typical for DC-only
 - 0.7Ω typical for AC/DC
- High-speed switching:
 - 0.1 ms (T_{ON}), 0.02 ms (T_{OFF}) typical
- High transient immunity: >1 kV/μs
- High input-to-output insulation voltage (safety and regulatory approvals)
 - 3750 Vrms for 1 minute per UL1577
 - CSA component acceptance

Applications

- Telecommunication switching
- Data communications
- Industrial controls
- Medical
- Security
- EMR/Reed Relay replacement

Functional Diagram

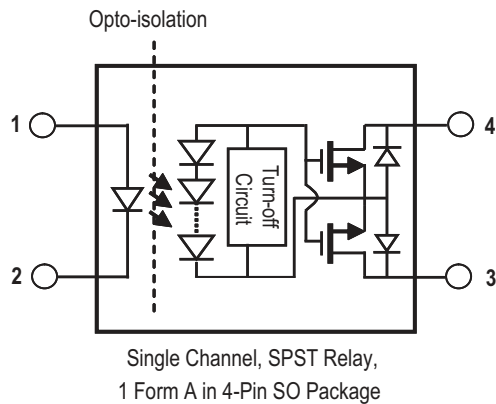

Truth Table

LED	Output
Off	Open
On	Close

Ordering Information

ASSR-xxxx is UL recognized with 3750 Vrms for 1 minute per UL1577 and is approved under CSA Component Acceptance Notice #5.

Part Number	Option	Package	Surface Mount	Gull Wing	Tape & Reel	Quantity
	RoHS Compliant					
ASSR-1410	-003E	SO-4	X			100 units per tube
	-503E		X		X	1500 units per reel
ASSR-1411	-001E	300-mil				50 units per tube
	-301E	DIP-6	X	X		50 units per tube
	-501E		X	X	X	1000 units per reel
ASSR-1420	-002E	300-mil				50 units per tube
	-302E	DIP-8	X	X		50 units per tube
	-502E		X	X	X	1000 units per reel

To order, choose a part number from the Part Number column and combine with the desired option from the Option column to form an order entry.

Example 1:

ASSR-1411-501E to order product of 300-mil DIP-6 gull wing surface mount package in tape and reel packaging and RoHS compliant.

Example 2:

ASSR-1420-002E to order product of 300-mil DIP-8 package in tube packaging and RoHS compliant.

Option data sheets are available. Contact your Broadcom sales representative or authorized distributor for information.

Schematics

ASSR-1410

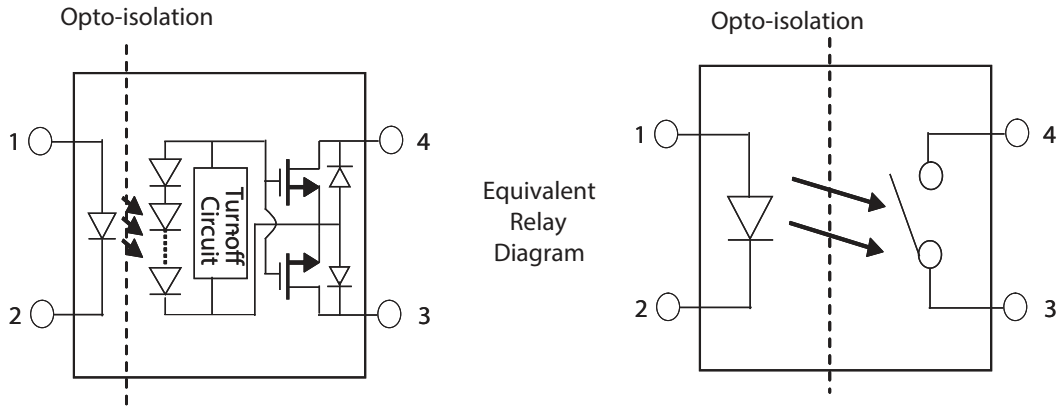

ASSR-1411 Connection A

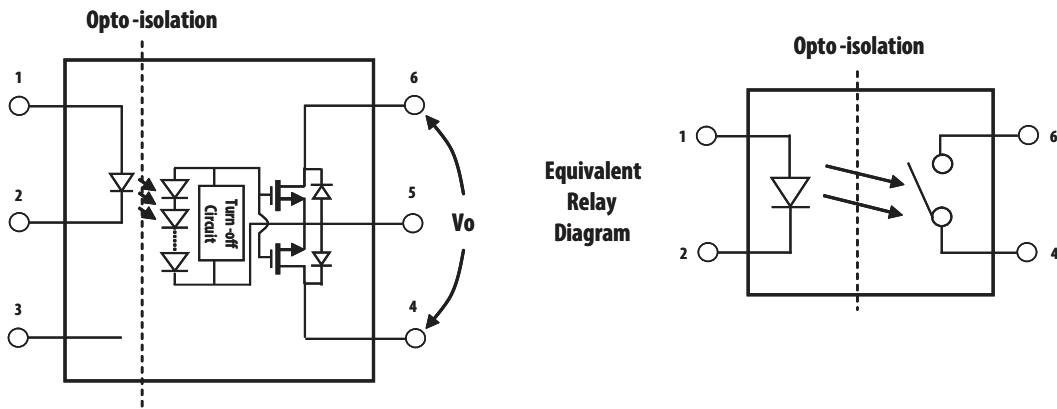

ASSR-1411 Connection B

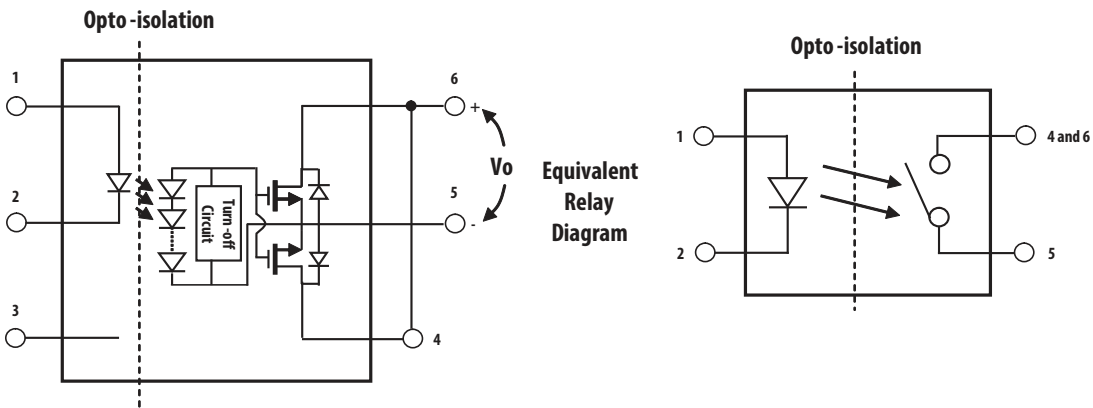

ASSR-1420

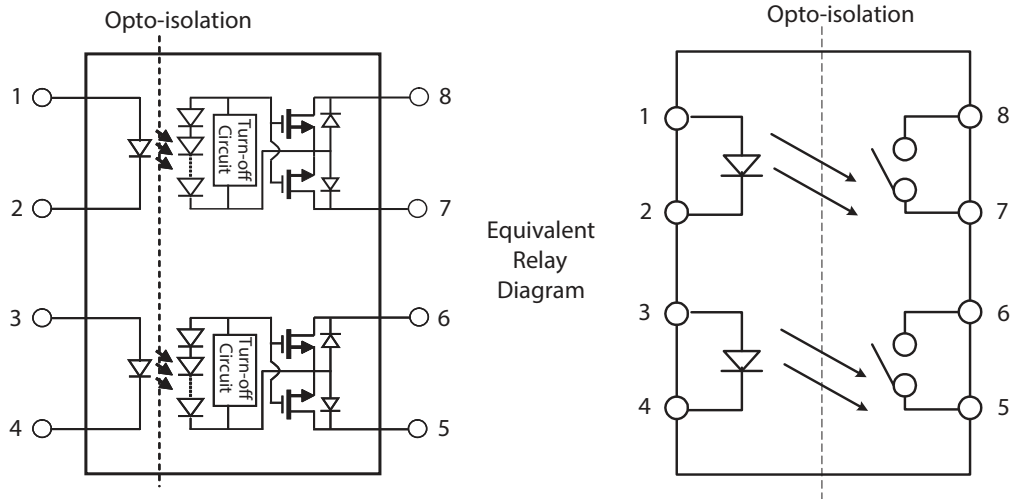

Package Outline Drawings

ASSR-1410 4-Pin Small Outline Package

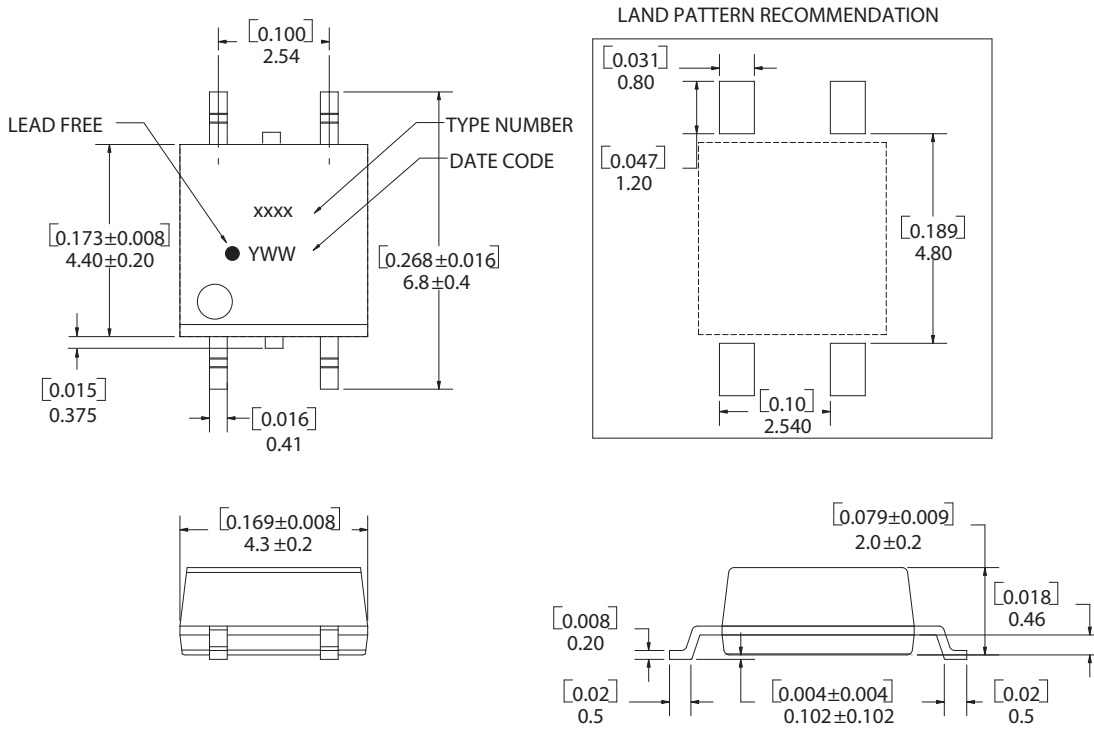

DIMENSIONS IN MILLIMETERS AND [INCHES]
 OPTION NUMBER 500 AND UL RECOGNITION NOT MARKED

ASSR-1411 6-Pin DIP Package

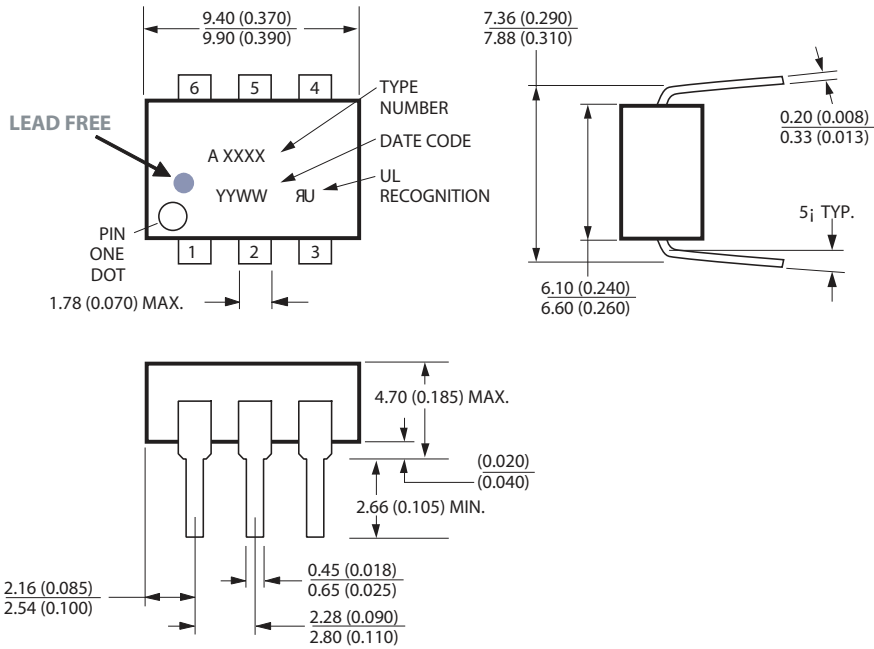

DIMENSIONS IN MILLIMETERS AND (INCHES).

ASSR-1411 6-Pin DIP Package with Gull Wing Surface Mount Option 300

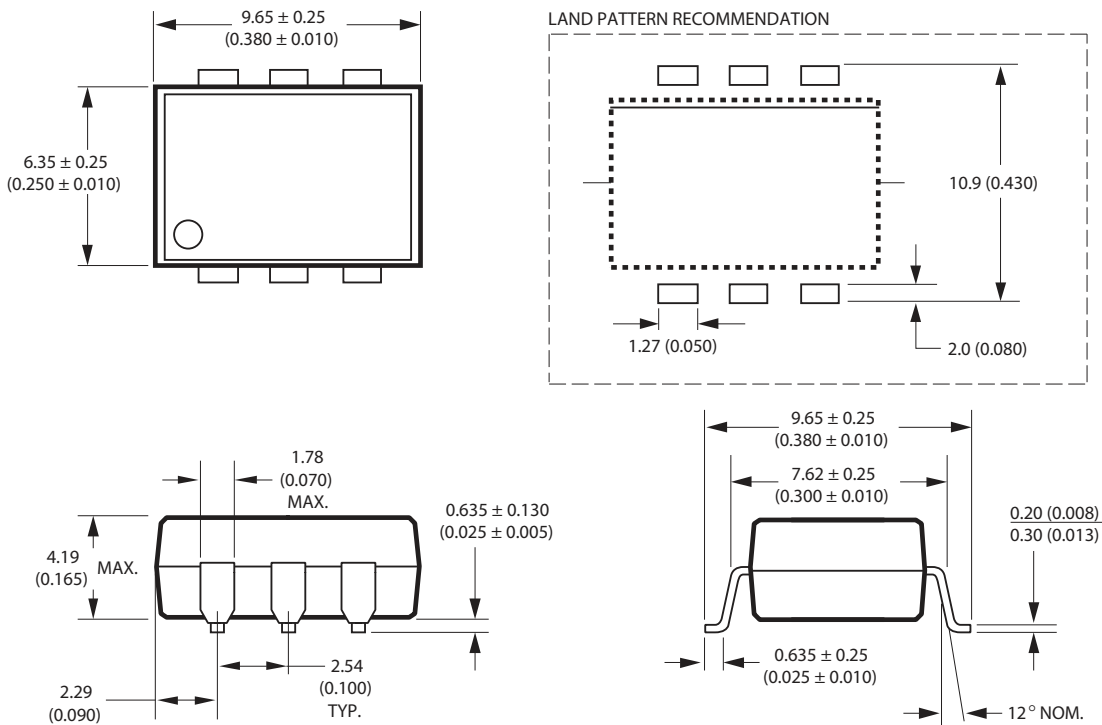

NOTE: FLOATING LEAD PROTRUSION IS 0.25 mm (10 mils) MAX.

ASSR-1420 8-Pin DIP Package

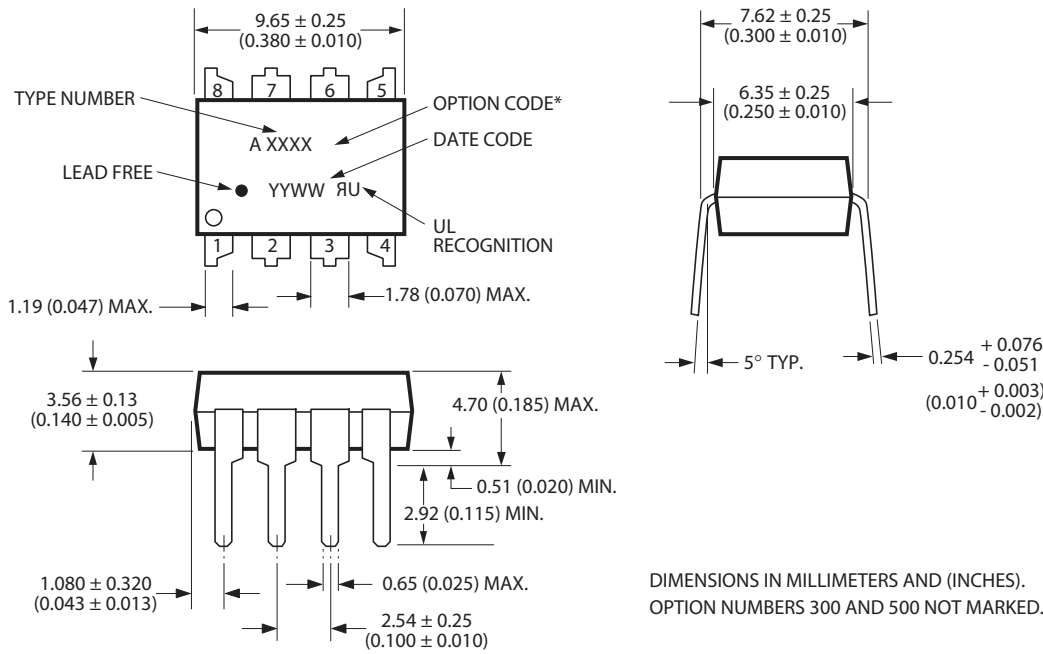

ASSR-1420 8-Pin DIP Package with Gull Wing Surface Mount Option 300

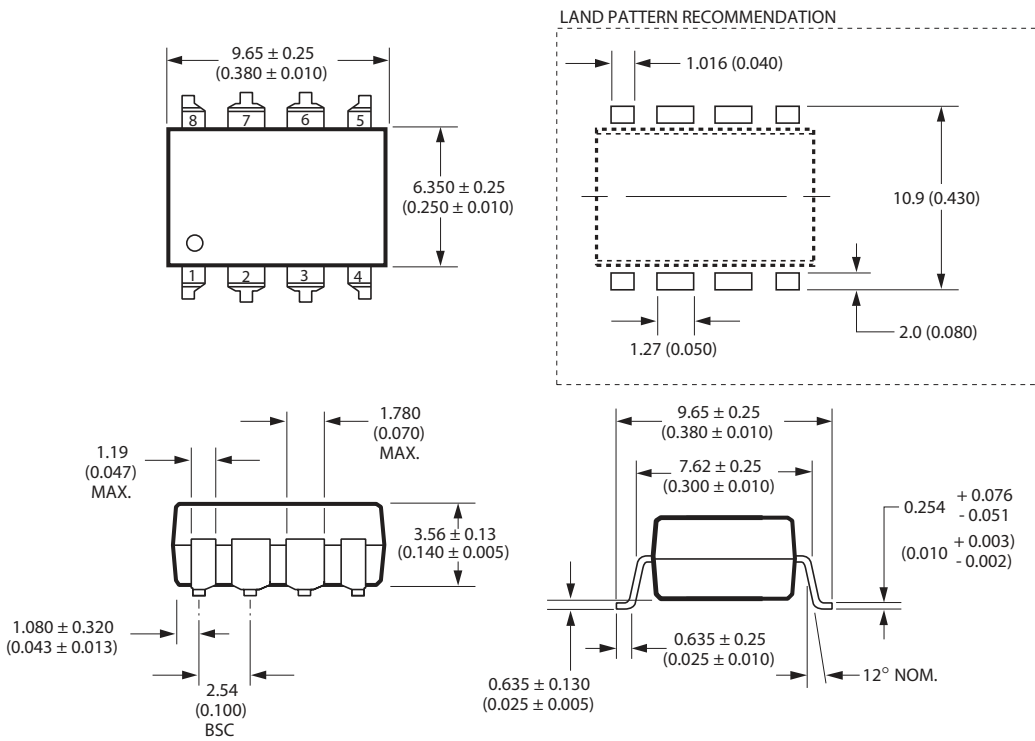

Solder Reflow Profile

Recommended reflow condition as per JEDEC Standard J-STD-020 (latest revision).

NOTE: Non-halide flux should be used.

Regulatory Information

The ASSR-1410, ASSR-1411, and ASSR-1420 are approved by the following organizations:

UL

Approved under UL 1577, component recognition program up to $V_{ISO} = 3750$ Vrms.

CSA

Approved under CSA Component Acceptance Notice #5.

Insulation and Safety Related Specifications

Parameter	Symbol	ASSR-1410	ASSR-1411 ASSR-1420	Unit	Conditions
Minimum External Air Gap (Clearance)	L(101)	4.9	7.1	mm	Measured from input terminals to output terminals, shortest distance through air.
Minimum External Tracking (Creepage)	L(102)	4.9	7.4	mm	Measured from input terminals to output terminals, shortest distance path along body.
Minimum Internal Plastic Gap (Internal Clearance)	—	0.08	0.08	mm	Through insulation distance conductor to conductor, usually the straight line distance thickness between the emitter and the detector.
Tracking Resistance (Comparative Tracking Index)	CTI	175	175	V	DIN IEC 112/VDE 0303 Part 1.
Isolation Group (DIN VDE0109)	—	IIIa	IIIa	—	Material Group (DIN VDE 0109).

Absolute Maximum Ratings

Parameter	Symbol	Min.	Max.	Unit	Note	
Storage Temperature	T_S	-55	125	°C		
Operating Temperature	T_A	-40	85	°C		
Junction Temperature	T_J	—	125	°C		
Lead Soldering Cycle	Temperature	—	260	°C		
	Time	—	10	s		
Input Current	Average	I_F	—	25	mA	
	Surge		—	50		
	Transient		—	1000		
Reversed Input Voltage	V_R	—	5	V		
Input Power Dissipation	ASSR-1410	P_{IN}	—	40	mW	
	ASSR-1411	P_{IN}	—	40	mW	
	ASSR-1420	P_{IN}	—	80	mW	
Output Power Dissipation	ASSR-1410	P_O	—	360	mW	
	ASSR-1411	P_O	—	720	mW	
	ASSR-1420	P_O	—	720	mW	
Average Output Current ($T_A = 25^\circ\text{C}$, $T_C \leq 100^\circ\text{C}$)	ASSR-1411 Connection A	I_O	—	0.6	A	a
	ASSR-1411 Connection B	I_O	—	1.2	A	
Output Voltage ($T_A = 25^\circ\text{C}$)	ASSR-1411 Connection A	V_O	-60	60	V	b
	ASSR-1411 Connection B	V_O	0	60	V	
Solder Reflow Temperature Profile	See Solder Reflow Profile .					

a. For derating, see [Figure 1](#), [Figure 2](#), [Figure 3](#), and [Figure 4](#).

b. The voltage across the output terminals of the relay should not exceed this rated withstand voltage. Overvoltage protection circuits should be added in some applications to protect against overvoltage transients.

Recommended Operating Conditions

Parameter	Symbol	Min.	Max.	Unit	Note
Input Current (ON)	$I_{F(ON)}$	3	20	mA	a
Input Voltage (OFF)	$V_{F(OFF)}$	0	0.8	V	
Operating Temperature	T_A	-40	+85	°C	

a. The threshold to switch the device is $I_F \geq 0.5$ mA; however, for qualified device performance over the temperature range, it is recommended to operate at $I_F = 5$ mA.

Package Characteristics

Unless otherwise specified, $T_A = 25^\circ\text{C}$.

Parameter	Symbol	Min.	Typ.	Max.	Unit	Conditions	Note
Input-Output Momentary Withstand Voltage	V_{ISO}	3750	—	—	Vrms	$\text{RH} \leq 50\%$, $t = 1 \text{ min}$	a, b
Input-Output Resistance	$R_{\text{I-O}}$	—	10^{12}	—	Ω	$V_{\text{I-O}} = 500 \text{ Vdc}$	
Input-Output Capacitance							a
ASSR-1410	$C_{\text{I-O}}$	—	0.4	—	pF	$f = 1 \text{ MHz}$; $V_{\text{I-O}} = 0 \text{ Vdc}$	
ASSR-1411	$C_{\text{I-O}}$	—	0.5	—	pF	$f = 1 \text{ MHz}$; $V_{\text{I-O}} = 0 \text{ Vdc}$	
ASSR-1420	$C_{\text{I-O}}$	—	0.8	—	pF	$f = 1 \text{ MHz}$; $V_{\text{I-O}} = 0 \text{ Vdc}$	

a. The device is considered a two-terminal device:

ASSR-1410 — Pin 1, 2 shorted and pin 3, 4 shorted.

ASSR-1411 — Pin 1, 2, 3 shorted and pin 4, 5, 6 shorted.

ASSR-1420 — Pin 1, 2, 3, 4 shorted and pin 5, 6, 7, 8 shorted.

b. The input-output momentary withstand voltage is a dielectric voltage rating that should not be interpreted as an input-output continuous voltage rating. For the continuous voltage rating, refer to the IEC/EN/DIN EN 60747-5-2 Insulation Characteristics Table (if applicable), your equipment level safety specification, or Broadcom Application Note 1074, *Optocoupler Input-Output Endurance Voltage*.

Electrical Specifications (DC)

Over recommended operating $T_A = -40^\circ\text{C}$ to 85°C , $I_F = 5 \text{ mA}$ to 10 mA , unless otherwise specified.

Parameter	Symbol	Min.	Typ.	Max.	Unit	Conditions	Figure	Note
Output Withstand Voltage	$ V_{\text{O(OFF)}} $	60	65	—	V	$V_F = 0.8\text{V}$, $I_O = 250 \mu\text{A}$, $T_A = 25^\circ\text{C}$		
		55	—	—	V	$V_F = 0.8\text{V}$, $I_O = 250 \mu\text{A}$	5	
Output Leakage Current	$I_{\text{O(OFF)}}$	—	—	1	μA	$V_F = 0.8\text{V}$, $V_O = 60\text{V}$		
Output Offset Voltage	$ V_{\text{OS}} $	—	1	—	μV	$I_F = 5 \text{ mA}$, $I_O = 0 \text{ mA}$		
Input Reverse Breakdown Voltage	V_R	5	—	—	V	$I_R = 10 \mu\text{A}$		
Input Forward Voltage	V_F	1.1	1.3	1.65	V	$I_F = 5 \text{ mA}$	6, 7	
Output On-Resistance	$R_{\text{(ON)}}$	—	0.2	1	Ω	$I_F = 5 \text{ mA}$, $I_O = 600 \text{ mA}$, Pulse $\leq 30 \text{ ms}$, $T_A = 25^\circ\text{C}$	8, 9	a
	$R_{\text{(ON)}}$	—	0.1	0.5	Ω	$I_F = 5 \text{ mA}$, $I_O = 1.2\text{A}$, Pulse $\leq 30 \text{ ms}$, $T_A = 25^\circ\text{C}$		

a. During the pulsed $R_{\text{(ON)}}$ measurement (I_O duration $\leq 30 \text{ ms}$), the ambient (T_A) temperature and case temperature (T_C) are equal.

Switching Specifications (AC)

Over recommended operating $T_A = -40^\circ\text{C}$ to 85°C , $I_F = 5\text{ mA}$ to 10 mA , unless otherwise specified.

Parameter	Symbol	Min.	Typ.	Max.	Unit	Conditions	Figure	Note
Turn-On Time	T_{ON}	—	0.25	0.9	ms	$I_F = 5\text{ mA}$, $I_O = 600\text{ mA}$, $T_A = 25^\circ\text{C}$	10, 14	
		—	—	1.0	ms	$I_F = 5\text{ mA}$, $I_O = 600\text{ mA}$	11	
		—	0.15	0.45	ms	$I_F = 10\text{ mA}$, $I_O = 600\text{ mA}$, $T_A = 25^\circ\text{C}$		
		—	—	0.5	ms	$I_F = 10\text{ mA}$, $I_O = 600\text{ mA}$		
Turn-Off Time	T_{OFF}	—	0.04	0.2	ms	$I_F = 5\text{ mA}$, $I_O = 600\text{ mA}$, $T_A = 25^\circ\text{C}$	12, 14	
		—	—	0.5	ms	$I_F = 5\text{ mA}$, $I_O = 600\text{ mA}$	13	
		—	0.034	0.15	ms	$I_F = 10\text{ mA}$, $I_O = 600\text{ mA}$, $T_A = 25^\circ\text{C}$		
		—	—	0.2	ms	$I_F = 10\text{ mA}$, $I_O = 600\text{ mA}$		
Output Transient Rejection	dV_O/dt	1	7	—	kV/ μs	$\Delta V_O = 60\text{V}$, $T_A = 25^\circ\text{C}$	15	
Input-Output Transient Rejection	dV_{I-O}/dt	1	≥ 10	—	kV/ μs	$\Delta V_{I-O} = 1000\text{V}$, $T_A = 25^\circ\text{C}$	16	

Applications Information

On-Resistance and Derating Curves

The Output On-Resistance, $R_{(ON)}$, specified in this data sheet is the resistance measured across the output contact when a pulsed current signal ($I_O = 0.6\text{A}$) is applied to the output pins. The use of a pulsed signal ($\leq 30\text{ ms}$) implies that each junction temperature is equal to the ambient and case temperatures. The steady-state resistance, R_{ss} , on the other hand, is the value of the resistance measured across the output contact when a DC current signal is applied to the output pins for a duration sufficient to reach thermal equilibrium. R_{ss} includes the effects of the temperature rise in the device.

Derating curves are shown in [Figure 1](#), [Figure 2](#), [Figure 3](#), and [Figure 4](#), specifying the maximum output current allowable for a given ambient temperature. The maximum allowable output current and power dissipation are related by the expression $R_{ss} = P_o(\text{max})/(I_o(\text{max}))^2$ from which R_{ss} can be calculated. Staying within the safe area ensures that the steady-state MOSFET junction temperature remains less than 125°C .

Turn-On Time and Turn-Off Time Variation

The ASSR-14xx Series exhibits a very fast turn-on and turn-off time. Both the turn-on and turn-off time can be adjusted by choosing proper forward current as depicted in [Figure 10](#) and [Figure 12](#). The changes of the turn-on and turn-off time with ambient temperature are also shown in [Figure 11](#) and [Figure 13](#).

Figure 1: Maximum Output Current Rating vs Ambient Temperature (ASSR-1410-003E)

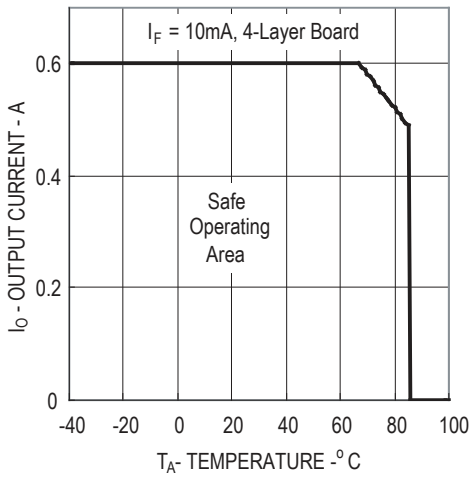

Figure 2: Maximum Output Current Rating vs Ambient Temperature (ASSR-1411-001E)

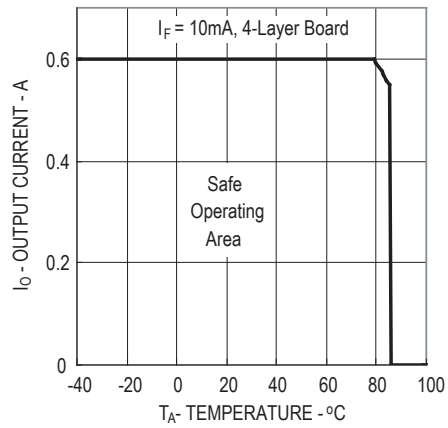

Figure 3: Maximum Output Current Rating vs Ambient Temperature (ASSR-1411-001E DC Connection)

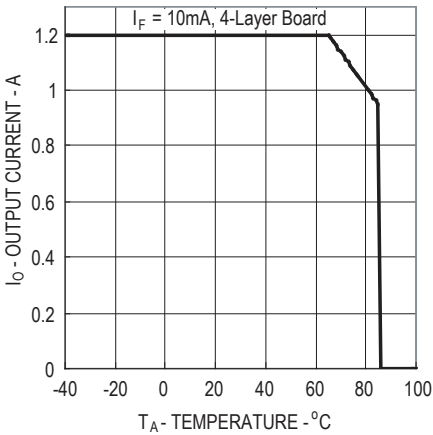

Figure 4: Maximum Output Current Rating vs Ambient Temperature (ASSR-1420-002E)

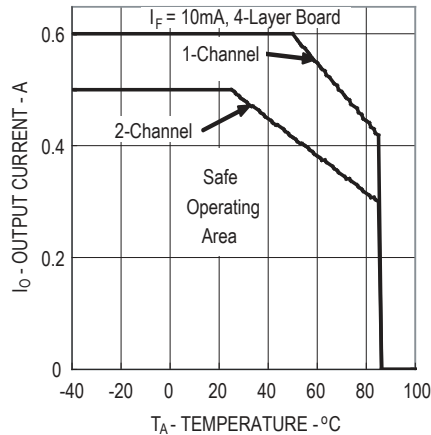

Figure 5: Normalized Typical Output Withstand Voltage vs. Temperature

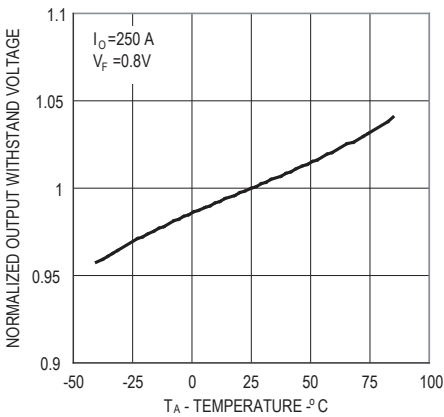

Figure 6: Typical Forward Voltage vs. Temperature

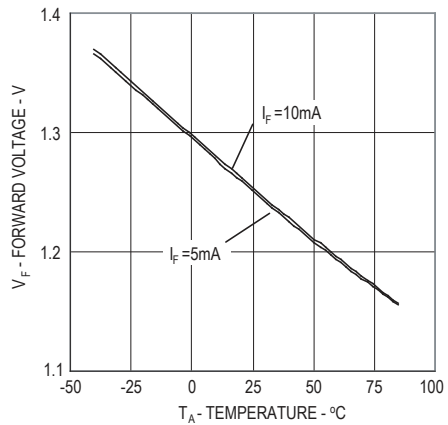

Figure 7: Typical Forward Current vs. Forward Voltage

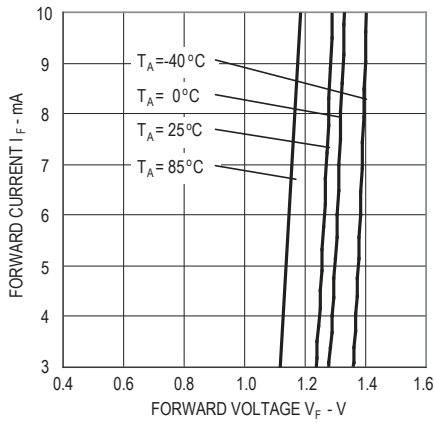

Figure 8: Typical On-Resistance vs. Temperature

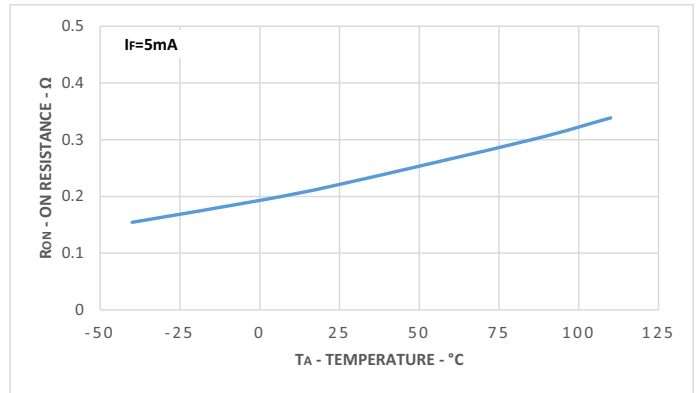

Figure 9: Typical Output Current vs. Output Voltage

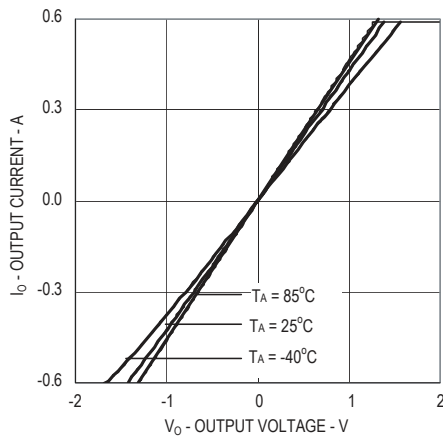

Figure 10: Typical Turn-On Time vs. Input Current

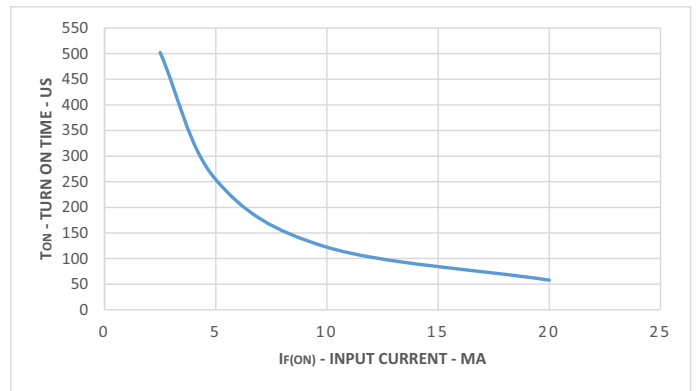

Figure 11: Typical Turn-On Time vs. Temperature

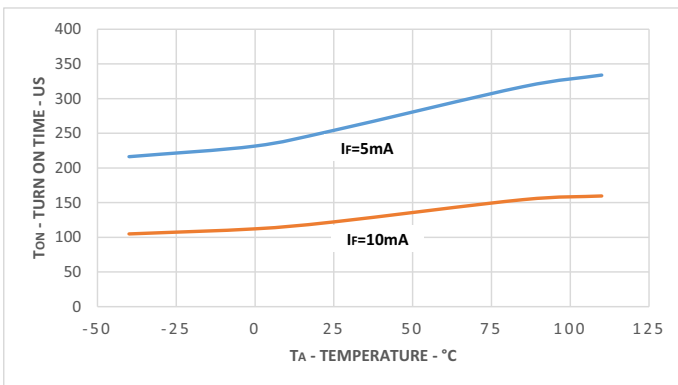

Figure 12: Typical Turn-Off Time vs. Input Current

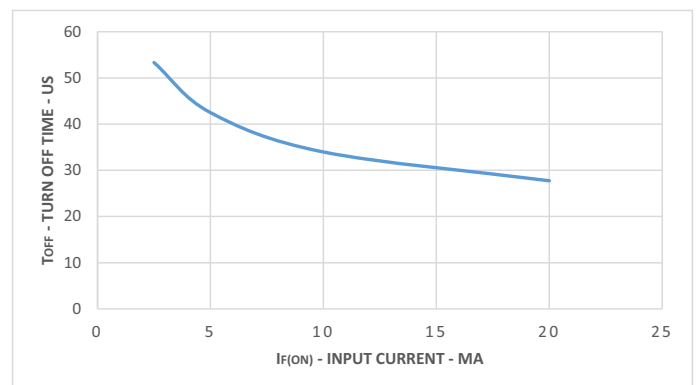

Figure 13: Typical Turn-Off Time vs. Temperature

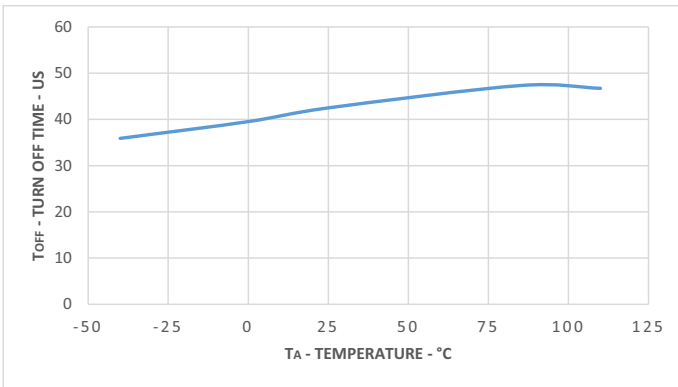

Figure 14: Switching Test Circuit for t_{ON}, t_{OFF}

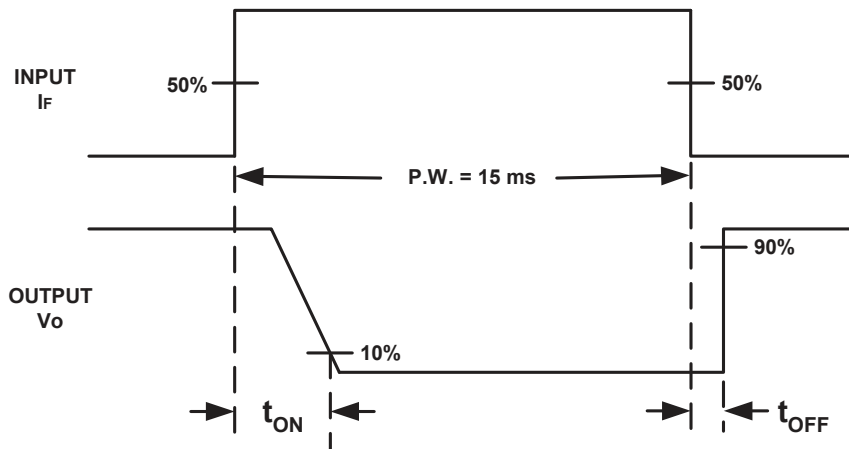
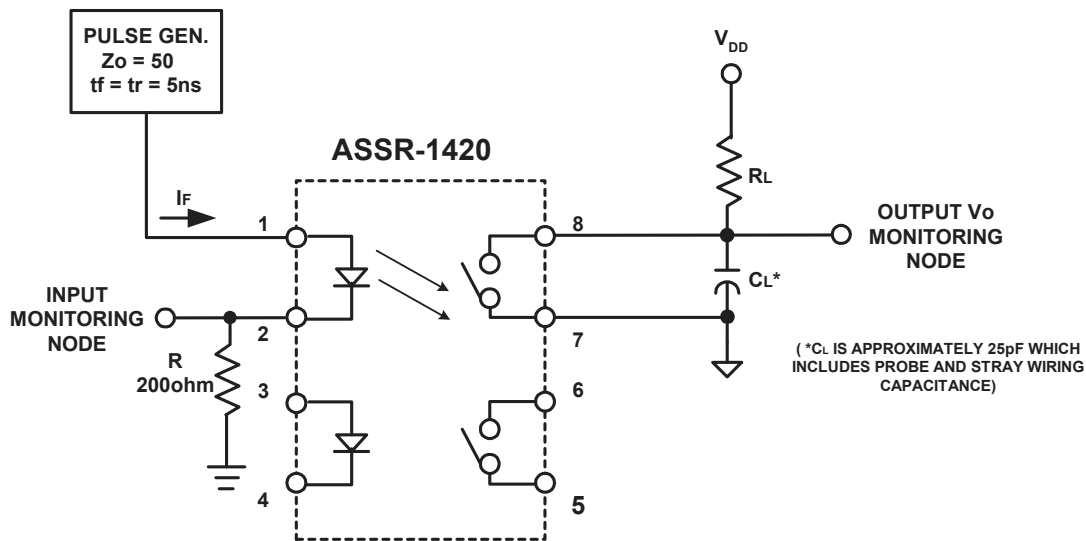
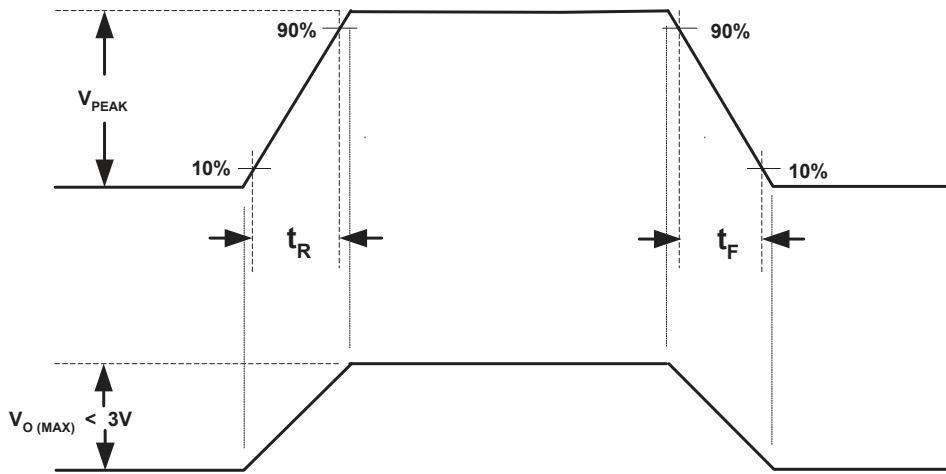
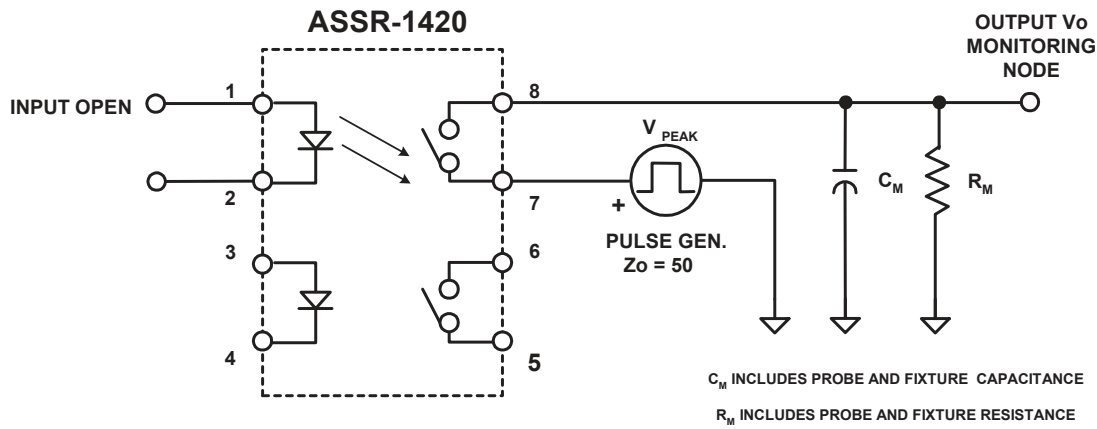

Figure 15: Output Transient Rejection Test Circuit



$$\frac{dV_o}{dt} = \frac{(0.8)V_{PEAK}}{t_R} \text{ OR } \frac{(0.8)V_{PEAK}}{t_F}$$

OVER SHOOT ON V_{PEAK} IS TO BE 10%

Figure 16: Input-Output Transient Rejection Test Circuit

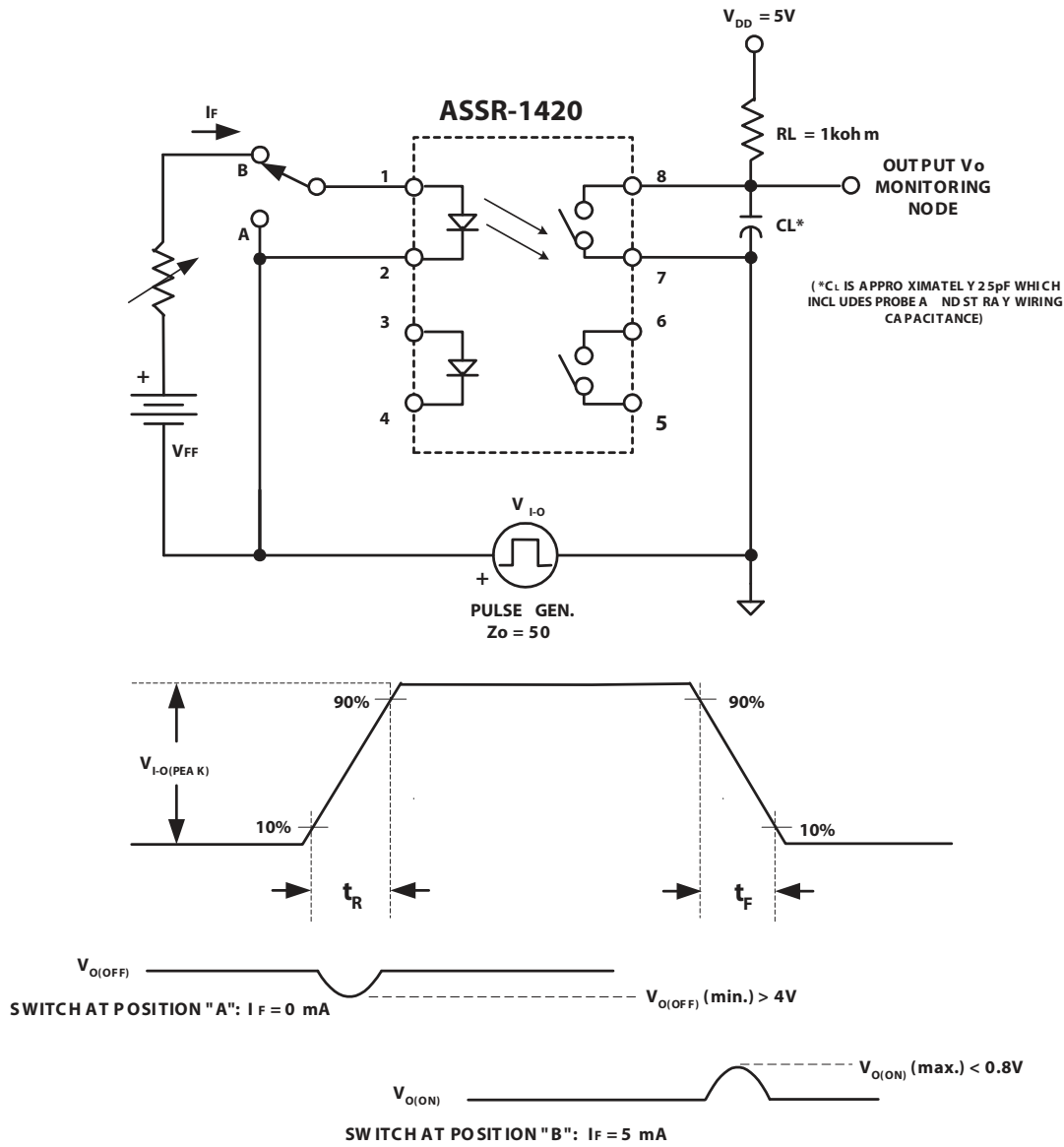

Copyright © 2005–2023 Broadcom. All Rights Reserved. The term “Broadcom” refers to Broadcom Inc. and/or its subsidiaries. For more information, go to www.broadcom.com. All trademarks, trade names, service marks, and logos referenced herein belong to their respective companies.

Broadcom reserves the right to make changes without further notice to any products or data herein to improve reliability, function, or design. Information furnished by Broadcom is believed to be accurate and reliable. However, Broadcom does not assume any liability arising out of the application or use of this information, nor the application or use of any product or circuit described herein, neither does it convey any license under its patent rights nor the rights of others.

