

LOADING PATTERN MATING SIDE

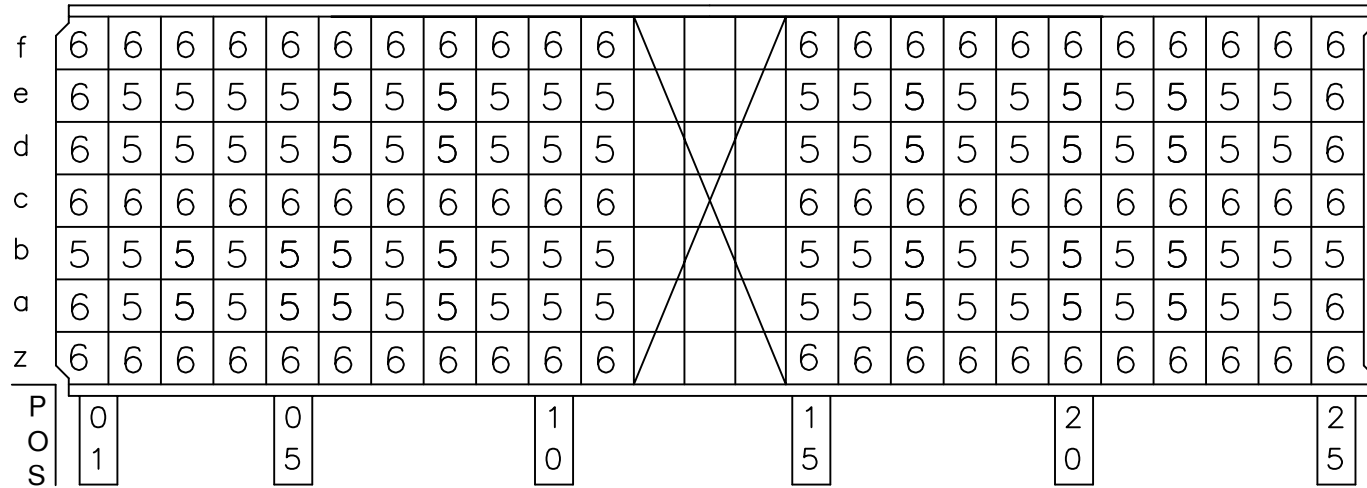

LOADED CONNECTOR ASSEMBLY (FOR EXAMPLE)

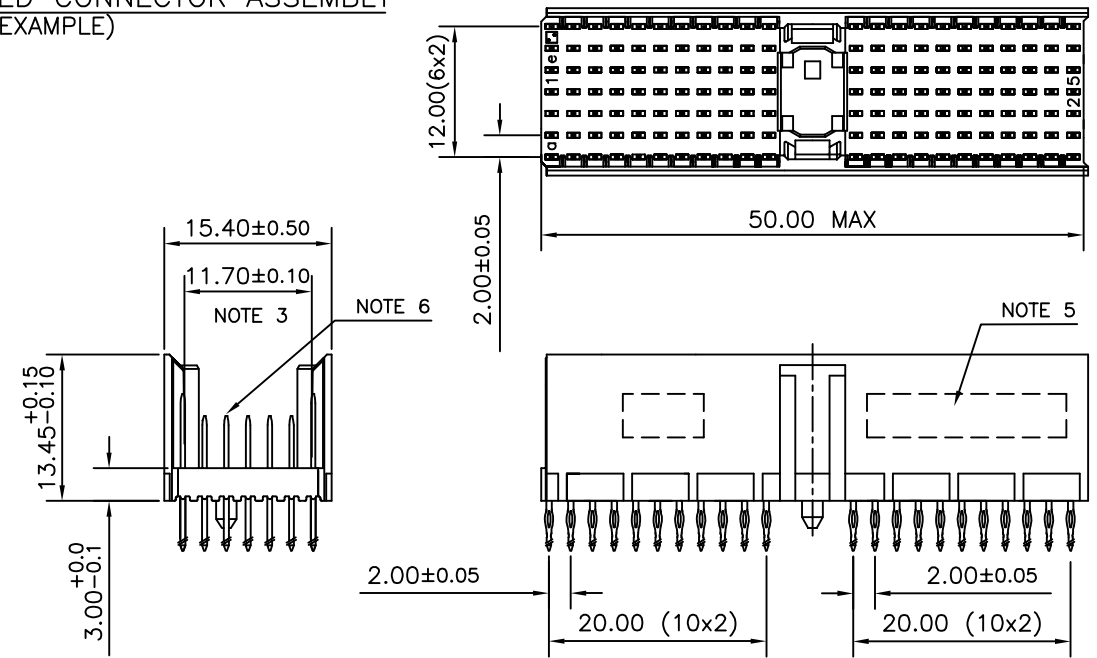

CONTACT OVERVIEW

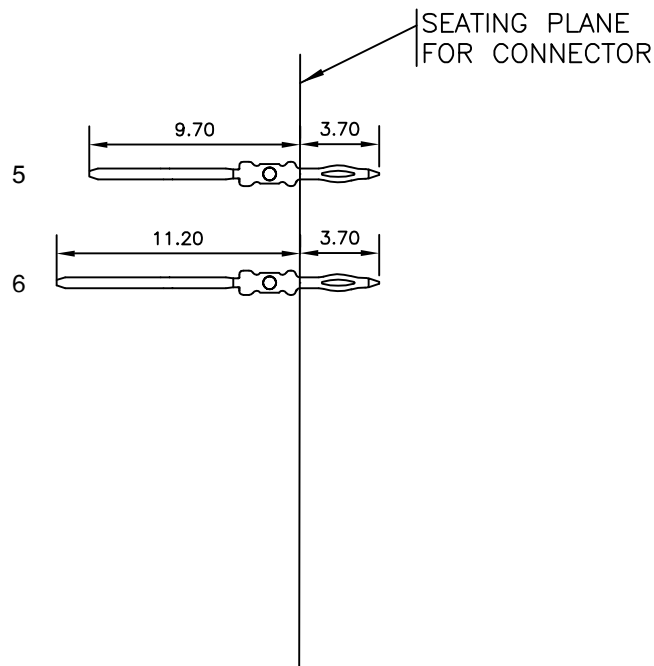

LAY-OUT P.C.B.-HOLE

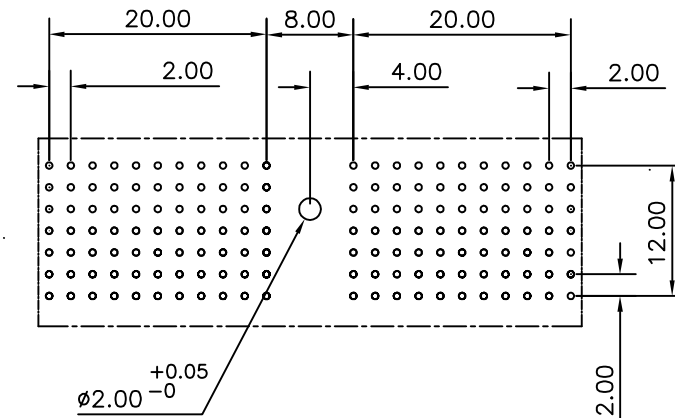

LEAD FREE INDICATOR : LF = LEAD FREE (DIGIT 15 & 16)

HM2P07PDW2N1

PLATING CODE (DIGIT 13 AND 14) (REF DRW NO. BS,C , 201844 , 003)

NOTES

- THIS PRODUCT IS CSA APPROVED.
- THIS PRODUCT IS UL RECOGNIZED.
- MEASURED AT THE BOTTOM.
- MATERIAL CONTACT: PHOSPHORBRONZE
HOUSING: CREAM WHITE GLASS FILLED POLYESTER UL-94V0
- CONNECTOR PRINTED WITH P/N AND DATE CODE.
- FOR ACTUAL CONTACT LOADINGS, SEE LOADING PATTERN MATING SIDE.
- SHAPE OF CONNECTOR HOUSING CAN ALTER DEPENDING ON PRODUCTION LOCATION
- THE PRODUCT (LF) MEETS EUROPEAN UNION DIRECTIVES AND OTHER COUNTRY REGULATIONS AS DESCRIBED IN GS-22-008
- FOR RECOMMENDED PTH DIMENSIONS REFER DRAWING : BS, A , 201572 , 001

CATALOG NO: HM2P07PDW2N1- ---

| | | | | | | | | | | | | | |
|---------------------------|--|----------------|--|-----------------------|--|-------------------------------|--|------------------|--|---------------------------------------|--|-----------------------------------|--|
| mat'l. code SEE NOTE 4 | | | | surface ISO 1302 ✓ | | tolerance ISO 406 ISO 1101 | | projection MM | | product family MLLIPACS | | | |
| ltr | | | | ecn no | | dr | | date | | tolerances unless otherwise specified | | title | |
| A | | | | 103-0042 | | BKP | | 06/08/2003 | | angles | | MPACS 5+2R STR HDR PF CONN TYPE A | |
| B | | | | 105-0182 | | MINI | | 03/10/2005 | | linear | | MM | |
| C | | | | 106-0077 | | MINI | | 22/06/2006 | | 0°±1° | | scale - | |
| | | | | | | | | dr | | MINI K VANDANATH | | 05/08/2003 | |
| | | | | | | | | enr | | BIJU K PAUL | | 05/08/2003 | |
| | | | | | | | | chr | | BIJU K PAUL | | 22/06/2006 | |
| | | | | | | | | appd | | BIJU K PAUL | | 22/06/2006 | |
| sheet index | | revision sheet | | c | | | | | | | | sheet 1 of 1 size 5 | |
| | | 1 | | | | | | | | | | A3 | |
| | | | | | | | | | | | | type Product Customer Drawing | |



Copyright FCI