

User Manual

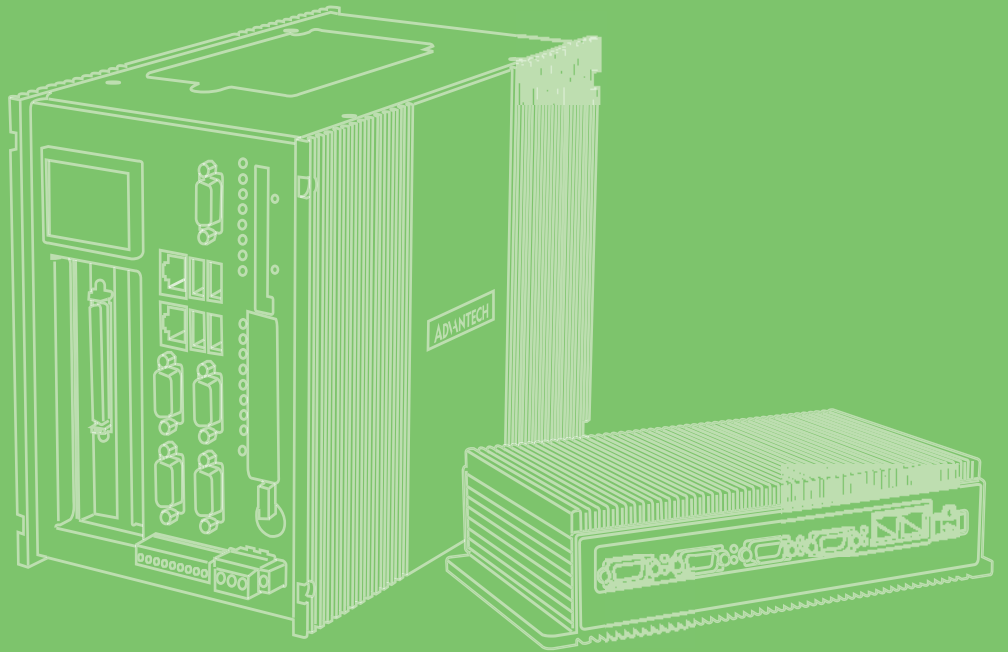

UNO-137 電腦

Intel Atom® E3940 processor
Automation Computer, with 2x
LAN, 2x COM, 4x USB, 2x DP, 8x
DIO, 1x mPCIe, and 1x M.2

ADVANTECH

Enabling an Intelligent Planet

Copyright

The documentation and the software included with this product are copyrighted 2020 by Advantech Co., Ltd. All rights are reserved. Advantech Co., Ltd. reserves the right to make improvements in the products described in this manual at any time without notice. No part of this manual may be reproduced, copied, translated or transmitted in any form or by any means without the prior written permission of Advantech Co., Ltd. Information provided in this manual is intended to be accurate and reliable. However, Advantech Co., Ltd. assumes no responsibility for its use, nor for any infringements of the rights of third parties, which may result from its use.

Acknowledgments

IBM, PC/AT, PS/2 and VGA are trademarks of International Business Machines Corporation.

Intel®, Core™ and Atom™ are the trademarks of Intel® Corporation

Microsoft Windows and MS-DOS are registered trademarks of Microsoft Corp.

All other product names or trademarks are properties of their respective owners.

Support

For more information on this and other Advantech products, please visit our website at <http://www.advantech.com>

For technical support services, please visit our support website at <http://support.advantech.com/>

This manual applies to the following models. These are abbreviated as UNO-137 products in this article

*Model name

UNO-137

*Part number:

UNO-137-E13BA

UNO137E13B2001-T,	UNO137E13B2002-T,	UNO137E13B2003-T,
UNO137E13B2004-T	UNO137E13B2005-T,	UNO137E13B2006-T,
UNO137E13B2007-T,	UNO137E13B2008-T,	UNO137E13B2009-T,
UNO137E13B2010-T	UNO137E13B2101-T,	UNO137E13B2102-T,
UNO137E13B2103-T,	UNO137E13B2104-T	UNO137E13B2105-T,
UNO137E13B2106-T,	UNO137E13B2107-T,	UNO137E13B2108-T,
UNO137E13B2109-T,	UNO137E13B2110-T	UNO137E13B2201-T,
UNO137E13B2202-T,	UNO137E13B2203-T,	UNO137E13B2204-T
UNO137E13B2205-T,	UNO137E13B2206-T,	UNO137E13B2207-T,
UNO137E13B2208-T,	UNO137E13B2209-T,	UNO137E13B2210-T
UNO137E13B2301-T,	UNO137E13B2302-T,	UNO137E13B2303-T,
UNO137E13B2304-T,	UNO137E13B2305-T,	UNO137E13B2306-T,
UNO137E13B2307-T,	UNO137E13B2308-T,	UNO137E13B2309-T,
UNO137E13B2310-T	UNO137E13B2401-T,	UNO137E13B2402-T,
UNO137E13B2403-T,	UNO137E13B2404-T	UNO137E13B2405-T,
UNO137E13B2406-T,	UNO137E13B2407-T,	UNO137E13B2408-T,

Part No. 2003013700

Printed in Taiwan

Edition 1

August 2020

UNO137E13B2409-T,
UNO137E13B2502-T,
UNO137E13B2505-T,
UNO137E13B2508-T,
UNO137E13B2601-T,
UNO137E13B2604-T,
UNO137E13B2607-T,
UNO137E13B2610-T

UNO137E13B2410-T,
UNO137E13B2503-T,
UNO137E13B2506-T,
UNO137E13B2509-T,
UNO137E13B2602-T,
UNO137E13B2605-T,
UNO137E13B2608-T,

UNO137E13B2501-T,
UNO137E13B2504-T,
UNO137E13B2507-T,
UNO137E13B2510-T
UNO137E13B2603-T,
UNO137E13B2606-T,
UNO137E13B2609-T,

Product Warranty (2 years)

Advantech warrants to you, the original purchaser, that each of its products will be free from defects in materials and workmanship for two years from the date of purchase.

This warranty does not apply to any products which have been repaired or altered by persons other than repair personnel authorized by Advantech, or which have been subject to misuse, abuse, accident or improper installation. Advantech assumes no liability under the terms of this warranty as a consequence of such events.

Because of Advantech's high quality-control standards and rigorous testing, most of our customers never need to use our repair service. If an Advantech product is defective, it will be repaired or replaced at no charge during the warranty period. For out-of-warranty repairs, you will be billed according to the cost of replacement materials, service time and freight. Please consult your dealer for more details.

If you think you have a defective product, follow these steps:

1. Collect all the information about the problem encountered. (For example, CPU speed, Advantech products used, other hardware and software used, etc.) Note anything abnormal and list any onscreen messages you get when the problem occurs.
2. Call your dealer and describe the problem. Please have your manual, product, and any helpful information readily available.
3. If your product is diagnosed as defective, obtain an RMA (return merchandise authorization) number from your dealer. This allows us to process your return more quickly.
4. Carefully pack the defective product, a fully-completed Repair and Replacement Order Card and a photocopy proof of purchase date (such as your sales receipt) in a shippable container. A product returned without proof of the purchase date is not eligible for warranty service.
5. Write the RMA number visibly on the outside of the package and ship it prepaid to your dealer.

Declaration of Conformity

CE

This product has passed the CE test for environmental specifications when shielded cables are used for external wiring. We recommend the use of shielded cables. This kind of cable is available from Advantech. Please contact your local supplier for ordering information.

FCC Class A

Note: This equipment has been tested and found to comply with the limits for a Class A digital device, pursuant to part 15 of the FCC Rules. These limits are designed to provide reasonable protection against harmful interference when the equipment is operated in a commercial environment. This equipment generates, uses, and can radiate radio frequency energy and, if not installed and used in accordance with the instruction manual, may cause harmful interference to radio communications. Operation of this equipment in a residential area is likely to cause harmful interference in which case the user will be required to correct the interference at his own expense.

警告使用者

這是甲類測試產品，在居住的環境中使用時，可能會造成射頻干擾，在這種情況下，使用者會被要求採取某些適當的對策。

Technical Support and Assistance

1. Visit the Advantech web site at www.advantech.com/support where you can find the latest information about the product.
2. Contact your distributor, sales representative, or Advantech's customer service center for technical support if you need additional assistance. Please have the following information ready before you call:
 - Product name and serial number
 - Description of your peripheral attachments
 - Description of your software (operating system, version, application software, etc.)
 - A complete description of the problem
 - The exact wording of any error messages

Safety Precaution - Static Electricity

Follow these simple precautions to protect yourself from harm and the products from damage.

- To avoid electric shock, always disconnect the power from your PC chassis before you work on it. Don't touch any components on the CPU card or other cards while the PC is on.
- Disconnect power before making any configuration changes. The sudden rush of power as you connect a jumper or install a card may damage sensitive electronic components.

Safety Instructions

1. Read these safety instructions carefully.
2. Keep this User Manual for later reference.
3. Disconnect this equipment from any AC outlet before cleaning. Use a damp cloth. Do not use liquid or spray detergents for cleaning.
4. For plug-in equipment, the power outlet socket must be located near the equipment and must be easily accessible.
5. Keep this equipment away from humidity.
6. Put this equipment on a reliable surface during installation. Dropping it or letting it fall may cause damage.

7. The openings on the enclosure are for air convection. Protect the equipment from overheating. **DO NOT COVER THE OPENINGS.**
 8. Make sure the voltage of the power source is correct before connecting the equipment to the power outlet.
 9. Position the power cord so that people cannot step on it. Do not place anything over the power cord.
 10. All cautions and warnings on the equipment should be noted.
 11. If the equipment is not used for a long time, disconnect it from the power source to avoid damage by transient over-voltage.
 12. Never pour any liquid into an opening. This may cause fire or electrical shock.
 13. Never open the equipment. For safety reasons, the equipment should be opened only by qualified service personnel.
 14. If one of the following situations arises, get the equipment checked by service personnel:
 - The power cord or plug is damaged
 - Liquid has penetrated into the equipment
 - The equipment has been exposed to moisture
 - The equipment does not work well, or you cannot get it to work according to the user's manual
 - The equipment has been dropped and damaged
 - The equipment has obvious signs of breakage
 15. **DO NOT LEAVE THIS EQUIPMENT IN AN ENVIRONMENT WHERE THE STORAGE TEMPERATURE MAY GO BELOW -40° C (-4 °F) OR ABOVE 70 °C (158 °F). THIS COULD DAMAGE THE EQUIPMENT. THE EQUIPMENT SHOULD BE IN A CONTROLLED ENVIRONMENT.**
 16. **CAUTION: DANGER OF EXPLOSION IF BATTERY IS INCORRECTLY REPLACED. REPLACE ONLY WITH THE SAME OR EQUIVALENT TYPE RECOMMENDED BY THE MANUFACTURER, DISCARD USED BATTERIES ACCORDING TO THE MANUFACTURER'S INSTRUCTIONS.**
 17. The sound pressure level at the operator's position according to IEC 704-1:1982 is no more than 70 dB (A).
 18. This product is intended to be supplied by an UL certified power supply or dc source with SELV output, rated 10 Vdc, 7.7A minimum and Tma 40 degree. If you need further assistance, please contact Advantech for further information.
 19. Ensure that the voltage of the power source is correct before connecting the equipment to a power outlet. The power outlet socket should have a grounded connection.
 20. For use in pollution free environments and indoor use.
 21. This equipment is not suitable for use in locations where children are likely to be present.
 22. If the equipment is used in a manner not specified by the Advantech, the protection provided by the equipment may be impaired.
 23. The equipment contains no user-serviceable parts. Do not open, Return to manufacturer for servicing.
 24. Do not block air ventilation holes.
 25. This is open type equipment and should be installed in a suitable enclosure.
- DISCLAIMER:** This set of instructions is given according to IEC 704-1. Advantech disclaims all responsibility for the accuracy of any statements contained herein.

Consignes de sécurité

1. Lire attentivement les instructions de sécurité.
2. Conserver ce manuel pour utilisation ultérieure,
3. Débranchez cet équipement de toute prise secteur avant de le nettoyer. Utilisez seulement un chiffon humide. N'utilisez pas de détergent liquide ou pulvérisé pour le nettoyage.
4. Gardez cet équipement à l'abri de l'humidité.
5. Placez cet équipement sur une surface fiable pendant l'installation. Le faire ou bien le laisser tomber peut causer des dégâts.
6. Les ouvertures sur l'enceinte servent à la convection de l'air. Protégez l'équipement contre surchauffe. **NE COUVREZ PAS LES OUVERTURES.**
7. Assurez-vous que la tension de la source d'alimentation est correcte avant de connecter l'équipement à une prise de courant. La prise de courant doit avoir une connexion à la terre.
8. Placez le câble d'alimentation de manière à ce que personne ne puisse marcher dessus. Ne placez rien sur le câble d'alimentation.
9. Toutes les mises en garde et tous les avertissements sur l'équipement doivent être notés.
10. Si l'équipement n'est pas utilisé pendant une longue période, débranchez-le de la source d'alimentation pour éviter tout endommagement dû à une surtension transitoire.
11. Ne jamais verser de liquide dans une ouverture. Cela pourrait provoquer un incendie ou un choc électrique.
12. N'ouvrez jamais l'équipement. Pour des raisons de sécurité, l'équipement doit être ouvert uniquement par du personnel qualifié.
13. Si l'une des situations suivantes se présente, faites vérifier l'équipement par le personnel de service:
 - un liquide a pénétré dans l'équipement
 - L'équipement a été exposé à l'humidité.
 - L'équipement ne fonctionne pas bien, ou vous ne pouvez pas le faire fonctionner selon le manuel de l'utilisateur.
 - The equipment does not work well, or you cannot get it to work according to the user's manual
 - L'équipement est tombé et endommagé
 - L'équipement présente des signes évidents de rupture.
14. **NE LAISSEZ PAS CET ÉQUIPEMENT DANS UN ENVIRONNEMENT OU LA TEMPÉRATURE DE STOCKAGE PEUT ÊTRE INFÉRIEURE À -40 ° C (-4 ° F) OU BIEN SUPÉRIEURE À 70 ° C (158 ° F). CECI POURRAIT ENDOMMAGER L'EQUIPEMENT. L'ÉQUIPEMENT DEVRAIT ÊTRE DANS UN ENVIRONNEMENT CONTRÔLÉ.**
15. Ce produit est destiné à être alimenté par une source d'alimentation certifiée UL ou par une source cc convenant à une utilisation à une température minimale de 40 degrés Celsius, dont la sortie est conforme à la norme SELV et dont la puissance nominale est de 10 Vdc, 7.7 A, en cas de besoin. contactez Advantech pour plus d'informations.
16. Pour une utilisation dans des environnements non polluant et à l'intérieur.
17. C'est appareil ne doit pas être utilisé dans des endroits où se trouvent des enfants.
18. Si l'équipement est utilisé d'une manière non spécifiée par le fabricant, la protection fournie par l'équipement peut être altéré

19. L'équipement ne contient aucune pièce réparable par l'utilisateur. Ne pas ouvrir, retourner au fabricant pour réparation.
20. Ne bloquez pas les ou es de ventilation.
21. Il s'agit d'un équipement de type ouvert et doit être installé dans un boîtier approprié

ATTENTION: Danger d'explosion si la batterie est mal remplacée. Remplacer uniquement par le même type ou équivalent recommandé par le fabricant. Jeter les piles usagées selon les instructions du fabricant.

安全指示

1. 請仔細閱讀此安全操作說明。
2. 請妥善保存此用戶手冊供日後參考。
3. 用濕抹布清洗設備前，請確認拔除電源線。請勿使用液體或去污噴霧劑清洗設備。
4. 對於使用電源線的設備，設備周圍必須有容易接觸到的電源插座。
5. 請勿在潮濕環境中試用設備。
6. 請在安裝前確保設備放置在可靠的平面上，意外摔落可能會導致設備損壞。
7. 設備機殼的開孔適用於空氣對流，從而防止設備過熱。請勿覆蓋開孔。
8. 當您連接設備到電源插座前，請確認電源插座的電壓符合要求。
9. 請將電源線佈置在人們不易絆倒的位置，請勿在電源線上覆蓋任何雜物。
10. 請注意設備上所有的警告標示。
11. 如果長時間不使用設備，請拔除與電源插座的連結，避免設備被超標的電壓波動損壞。
12. 請勿讓任何液體流入通風口，以免引起火災或短路。
13. 請勿自行打開設備。為了確保您的安全，請透過經認證的工程師來打開設備。
14. 如遇下列情況，請由專業人員維修：
 - 電源線或插頭損壞；
 - 設備內部有液體流入；
 - 設備曾暴露在過度潮濕環境中使用；
 - 設備無法正常工作，或您無法透過用戶手冊來正常工作；
 - 設備摔落或損壞；
 - 設備有明顯外觀損；
15. 請勿將設備放置在超出建議溫度範圍的環境，即不要低於 -40°C (-40°F) 或高於 70°C (158°F)，否則可能會造成設備損壞。
16. 注意：若電池更換不正確，將有爆炸危險。因此，只可以使用製造商推薦的同一種或者同等型號的電池進行替換。請按照製造商的指示處理舊電池。
17. 根據 IEC 704 - 1:1982 規定，操作員所在位置音量不可高於 70 分貝。
18. 限制區域：請勿將設備安裝於限制區域使用。
19. 免責聲明：請安全訓示符合 IEC 704 - 1 要求。研華公司對其內容之準確性不承擔任何法律責任。
20. 消費者若使用電源适配器供电，则应购买配套使用获得 CCC 认证并满足标准要求的电源适配器。

Contents

Chapter 1	Overview.....	1
1.1	Introduction	2
1.2	Safety Precautions	2
1.3	Packing List.....	3
1.4	Hardware Specifications	3
1.4.1	General	3
1.4.2	System Hardware	4
1.4.3	I/O Interfaces	4
1.4.4	Environment.....	4
1.4.5	Certifications	5
1.4.6	Extension Kit (Optional).....	5
1.5	Dimensions	6
	Figure 1.1 UNO-137 Dimensions.....	6
	Figure 1.2 UNO-137 Dimensions (With Optional Extension kit) ..	6
Chapter 2	Hardware Functionality	7
2.1	Introduction	8
	Figure 2.1 Diagram of Connector Locations on UNO-137 (Top Side)	8
	Figure 2.2 Diagram of Key Components Location on UNO-137 (Bottom Side).....	8
	Table 2.1: Key components, Connectors on Board.....	9
2.2	External I/O Connector.....	10
	Figure 2.3 Front Panel of UNO-137.....	10
	Figure 2.4 Top View of UNO-137	10
2.2.1	Power Connector	11
2.2.2	LAN: Ethernet Connector.....	11
2.2.3	USB Connector.....	11
2.2.4	Display Connector.....	11
2.2.5	COM Connector.....	12
	Table 2.2: COM Connector Pin Assignments.....	12
2.2.6	Digital Input and Output	13
	Figure 2.5 Isolated DI Wet Connection Diagram	14
	Figure 2.6 Isolated DI Dry Connection Diagram	14
	Figure 2.7 Isolated DO Connection Diagram.....	14
2.3	Internal I/O Connectors and Switches.....	15
	Figure 2.8 Locations Internal I/O Connectors/Switches for UNO-137.....	15
	Table 2.3: Internal Connectors and Jumper Switches	15
2.3.1	SATA Connector/SATA Power Connector.....	16
2.3.2	M.2 Connector	16
2.3.3	mPCIe Connector	16
2.3.4	Nano SIM Slot.....	16
2.4	Others	17
	Figure 2.9 LED Indicators, Reset Buttons, and Antenna Hole...	17
2.4.1	LED Indicators	17
2.4.2	Reset Buttons	17
2.4.3	Antenna Hole	18
	Figure 2.10Diagram of Maximum OD Value for Antenna Hole...	18
Chapter 3	Initial Setup	19

3.1	Chassis Grounding	20
	Figure 3.1 Chassis Grounding Connection Diagram	20
3.2	Connecting Power.....	20
3.3	Storage Installation (optional)	21
	3.3.1 Installing a 2.5" HDD/SSD	21
	3.3.2 Installing M.2 SSD	24
3.4	Din-Rail Installation	25
3.5	Wireless Module Installation (Optional)	26
3.6	Extension Kit Installation (Optional).....	30
3.7	Remote Power & Reset Settings	34
	Table 3.1: Remote Power/On & Reset Settings	34
3.8	BIOS Setting	34

Appendix A System Settings/Pin Assignments.. 35

A.1	Power Connector (CN1).....	36
	Table A.1: Power Connector Pin Assignments.....	36
A.2	LAN: Ethernet Connector (CN4)	36
	Table A.2: Ethernet Connector Pin Assignments	36
A.3	USB Connector (CN5,CN6)	37
	A.3.1 USB 2.0 Connector.....	37
	Table A.3: Connector Pin Assignments	37
	A.3.2 USB 3.0 Connector.....	37
	Table A.4: USB 3.0 Connector Pin Assignments.....	37
A.4	Display Connector (CN2,CN3).....	38
	Table A.5: Display Port Adapter cable Pin Assignments	38
A.5	SATA Connector/ SATA Power Connector	39
	A.5.1 SATA Connector (SATA1).....	39
	Table A.6: SATA Connector Pin Assignments.....	39
	A.5.2 SATA Power Connector (CN9).....	39
	Table A.7: SATA Power Connector Pin Assignments	39
A.6	M.2 Connector (CN15).....	40
	Table A.8: M.2 B Key Connector Pin Assignments	40
A.7	mPCIe Connector (MINI1)	41
	Table A.9: mPCIe Connector Pin Assignments	41
A.8	COM Port RS232/422/485 Settings	42
	A.8.1 RS232/422/485 Setting (SW1)	42
	A.8.2 COM Port RS422/485 Termination Resistor Setting	43
A.9	AT/ATX Setting (SW8).....	43
A.10	Board to Board Connector (Reserved for Expansion) (CN13).....	44
	Table A.10:Expansion Board to Board Connector Pin Assignments	
	44	
A.11	TPM 2.0 BIOS Setting.....	45
A.12	CPU Turbo Mode BIOS Setting	46

Chapter 1

Overview

This chapter overviews specifications for UNO-137.

- Introduction
- Safety Precautions
- Accessories
- Hardware Specifications
- Dimensions

1.1 Introduction

Advantech's new UNO-1 series serve as modular Integrated Edge Controllers. They provide configuration flexibility for customers seeking to cost effectively optimize their services. The new integrated Din-rail mounting kit is designed to be more ruggedized and user-friendly, making it a perfect fit for control cabinets.

This new UNO-137 model features a ruggedized design with an industrial-grade Intel Atom® E3940 1.6GHz processor and built-in 8GB DDR3L RAM. It supports a wide temperature range (-40 ~ 70 °C/-40 ~ 158 °F) and sufficient I/O - including 2 x LAN, 2 x RS-232/422/485, 3 x USB 3.0, 1 x USB 2.0, 8 x DI, 8 x DO, and 2 x DP++. It also supports 1x full-size Mini PCIe slot, 1x M.2, and 1x Nano SIM card slots to enable expansion. An optional 2nd stack extension kit supports 1 x iDoor module, such as industrial Fieldbus, as well as I/O and peripheral modules. This expandability makes Advantech's UNO-1 series an excellent choice for various industrial applications. Additionally, UNO-1's flexible expandability and control functions meet emerging demands for industry 4.0.

1.2 Safety Precautions

Below are a few safety precautions for preventing injury when making connections. In most cases, users can use a standard cable for connection.

Warning! *Always disconnect the power cord from the chassis before manual handling. Do not connect the chassis while the system power is on. A sudden rush of power can damage sensitive electronic components. Only experienced electronics personnel should open the chassis.*



Warning! *Toujours à la terre pour éliminer toute charge d'électricité statique avant toucher UNO-137. Appareils électroniques modernes sont très sensibles à charges d'électricité statique. Utilisez un bracelet antistatique à tout moment. Placez tous composants électroniques sur une surface antistatique ou dans un statique-sac blindé.*



Caution! *Always ground yourself to remove any static electric charge before touching UNO-137. Modern electronic devices are very sensitive to static electric charges. Use a grounding wrist strap at all times. Place all electronic components on a static-dissipative surface or in a static shielded bag.*



Caution! *Toujours débrancher le cordon d'alimentation de votre boîtier lorsque vous êtes travailler. Ne branchez pas lorsque l'appareil est allumé. Un afflux soudain de puissance peut endommager les composants électroniques sensibles. Seulement connu personnel de l'électronique devraient ouvrir le châssis.*



1.3 Packing List

Please refer to below packing list:

- UNO-137 (with din-rail mount)
- 1 x 2x5 Plug-in block for COM port
- 1 x 2x1 Plug-in block for power wiring
- 1 x 2x10 Plug-in block for digital I/O wiring
- 4x M3x5L screws for HDD installation
- 1x M2x4L screw for mPCIe card installation
- 1 x Earth-Ground cable
- 1 x SATA cable
- Quick Start Guide
- Simplified Chinese manual
- China RoHs sheet
- Warranty card

If anything is missing or damaged, contact your distributor or sales representative immediately.

1.4 Hardware Specifications

1.4.1 General

Dimensions (W x D x H)	35 x 105 x 150 mm (1.4 x 4.1 x 5.9 in)
Weight (Net)	0.8 kg (1.7 lbs)
Mounting	DIN-rail
Power Requirement	10 - 36V _{DC}
Power Consumption	21W (typical), 47W (Max) *For USB iDoor(PCM-24U2U3-BE): Max to 56W *For PoE iDoor(PCM-24R2PE-AE): Max to 77W

1.4.2 System Hardware

BIOS	AMI UEFI 128Mbit
Watchdog Timer	Programmable 255 levels timer interval, from 1 to 255 sec
Hardware Security	TPM 2.0
Processor	Intel Atom® E3940 1.6GHz (up to 1.8GHz)
Memory	Built-in 8GB DDR3L 1600MHz (Up to 8GB)
Graphics Engine	Intel® HD Graphics
Ethernet	Intel® i210-IT GbE, IIEEE802.1AS, 802.3az
LED Indicators	1x Programmable, 1x Power, 1x RTC Battery and LAN (Active, Status)
Storage	1 x M.2 B-key 2242 SSD (SATA/USB Signal) 1 x 2.5"SSD/HDD (up to 9.5 mm/0.37 in in height)
Expansion	1 x Full size mPCIe slot (PCIe/USB Signal) 1 x M.2 B-key 3042 or 3052 Module (SATA/USB Signal) 1 x Nano SIM card slot

Note! The M.2 B key can support either 2242 (w/SATA signal) or 3042/3052 Module (w/ USB signal)



1.4.3 I/O Interfaces

Serial Ports	2 x RS-232/422/485 (terminal block), 50 ~115.2 kbps (Isolation Protection: 2500 V _{DC})
LAN Ports	2 x 10/100/1000 Mbps IEEE 802.3u 1000BASE-T Fast Ethernet (RJ-45)
USB Ports	3 x USB 3.2 Gen1, and 1 x USB 2.0 (Type A)
Isolated DIO	8-ch digital input, 8-ch digital output (Isolation Protection: 2500V _{DC})
Displays	2 x DP 1.2, up to 4096x2306@60Hz
Power Connector	1 x 2 Pin (terminal block)

1.4.4 Environment

Operating Temperature*	-40 ~ 70 °C (-40 ~ 158 °F) with 0.7m/s airflow, with wide-temp (-40 ~ 85 °C/-40 ~ 185 °F) peripherals (e.g. Memory, 2.5" SSD/HDD, wireless modules)
Storage Temperature	- 40 ~ 85 °C (-40 ~ 185 °F)
Relative Humidity	95% RH @ 40 °C/104 °F, non-condensing
Shock Protection	Operating, IEC 60068-2-27, 50G, half sine, 11ms
Vibration Protection	Operating, IEC 60068-2-64, 4Grms, random, 5 ~500Hz, 1hr/ axis (SSD) Operating, IEC 60068-2-64, 0.3 Grms, random, 5 ~ 500Hz, 1hr/ axis (HDD)

Note! It is recommended to use 2.5" SSD under the temperature of 70 °C/158 °F.



1.4.5 Certifications

Certification	CE, FCC, UL 61010-2-201, CCC, BSMI
----------------------	------------------------------------

1.4.6 Extension Kit (Optional)

UNO-137 features a modularized design. Advantech offers an optional 2nd stack extension kit for users to expand the functionality using an Advantech iDoor module.

Part number	UNO-137-ID1EA
Description	2nd stack extension kit to support 1 x iDoor on UNO-137-E13BA
Ports	1 x iDoor
Dimensions (W x D x H)	35 x 105 x 150 mm (1.4 x 4.1 x 5.9 in)
Weight	0.2 kg (0.4 lbs)

Note! *The system operating temperature can keep 60 °C (140 °F) with most of the iDoor modules. (Exception: PoE iDoor, USB 3.0 iDoor)*



1.5 Dimensions

35 x 105 x 150 mm (1.4 x 4.1 x 5.9 in)

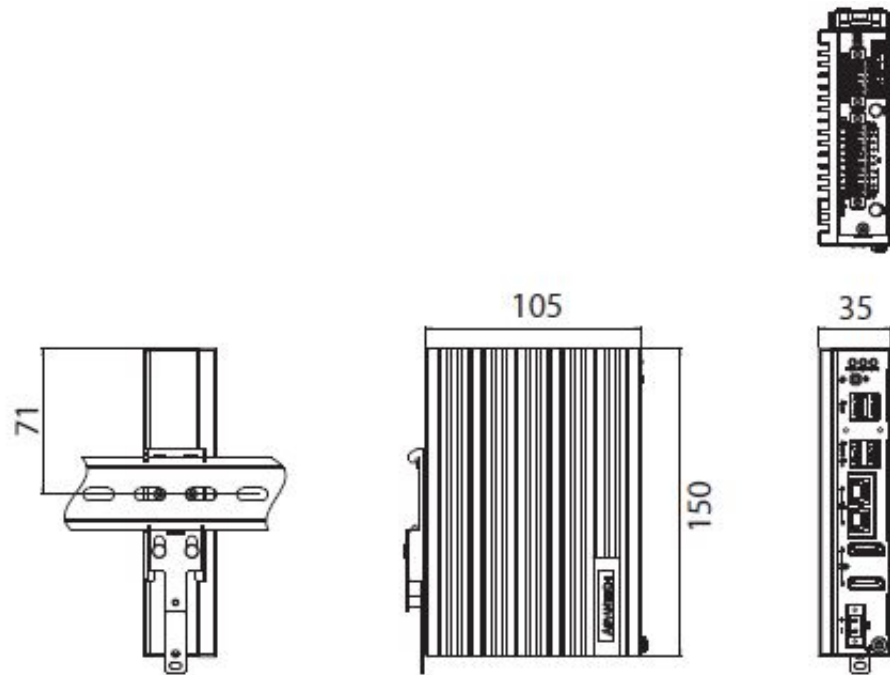

Figure 1.1 UNO-137 Dimensions

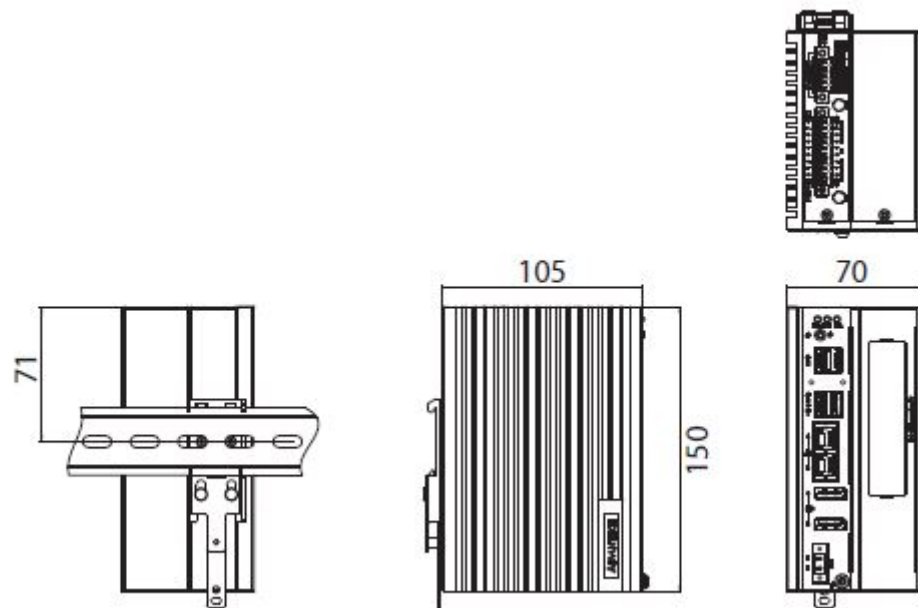

Figure 1.2 UNO-137 Dimensions (With Optional Extension kit)

Chapter 2

Hardware Functionality

This chapter details setup instructions for UNO-137's hardware functions. It includes connecting peripherals and indicators.

- Introduction
- External I/O Connector
- Internal I/O Connector
- LED Indicators
- Reset Buttons
- Antenna Hole

2.1 Introduction

The following diagram demonstrates the location of UNO-137's motherboard's key components and internal/external connectors.

TOP

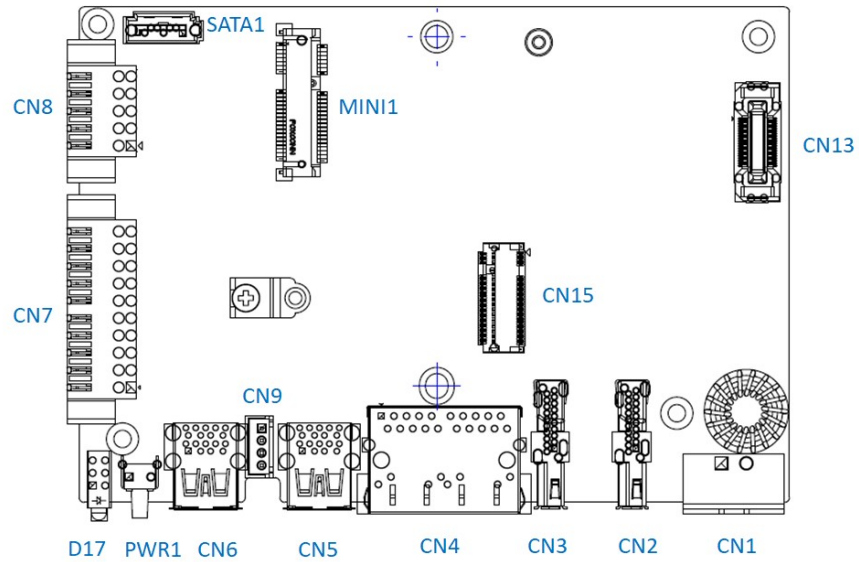

Figure 2.1 Diagram of Connector Locations on UNO-137 (Top Side)

BOT

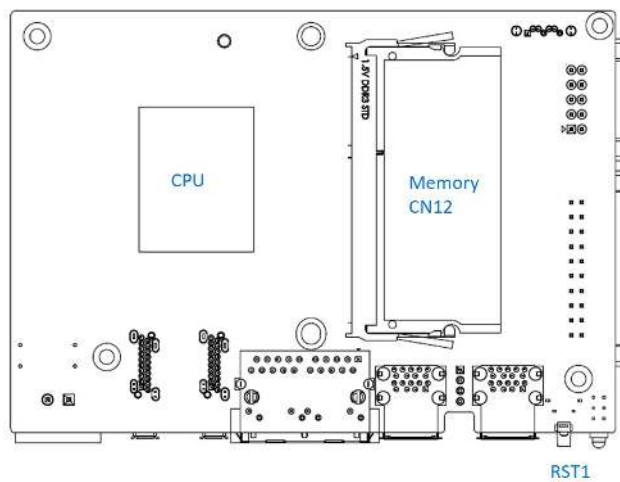

Figure 2.2 Diagram of Key Components Location on UNO-137 (Bottom Side)

Table 2.1: Key components, Connectors on Board		
Category	Label	Function
External	PWR1	Power Button
	RST1	Reset Button
	CN1	Power Connector
	CN2	Displayport Connector
	CN3	Displayport Connector
	CN4	LAN Connector
	CN5	USB 2.0+3.0 Connector
	CN6	USB 3.0 Connector
	CN7	8DI/ 8DO Terminal Connector
	CN8	COM Port Terminal Connector (RS232/422/485)
Internal	CN9	SATA Power Connector
	SATA1	SATA Signal Connector
	MINI1	MiniPCIe Connector
	CN13	Reserve for connector expansion
	CN15	M.2 B key for 2242/3042/3052 Connector
	CN12	Memory slot

2.2 External I/O Connector

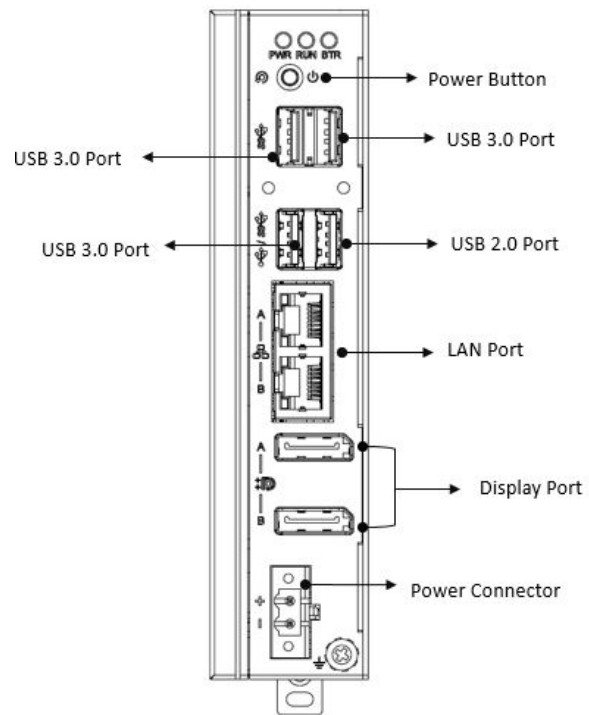

Figure 2.3 Front Panel of UNO-137

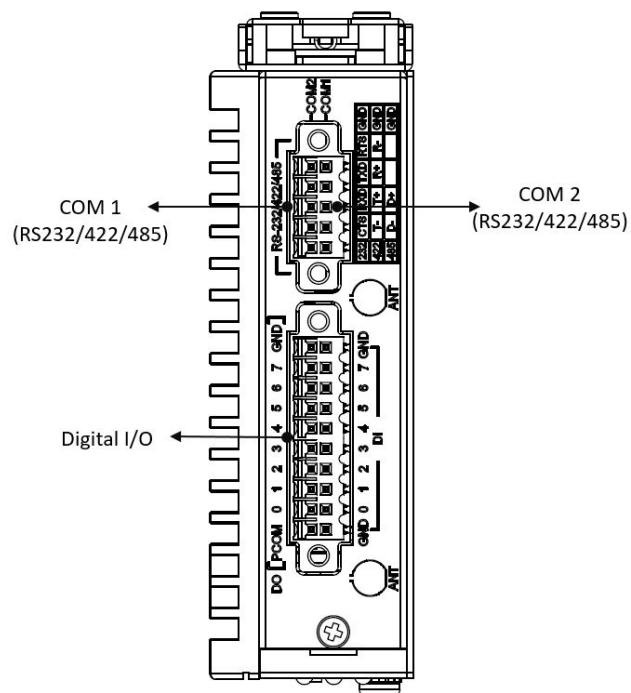

Figure 2.4 Top View of UNO-137

2.2.1 Power Connector

UNO-137 comes with a Phoenix connector that carries 10 - 36 V_{DC} external power input, and features reversed wiring protection. Therefore, the system will not accrue damage from reversed polarity of ground lines and power lines. (Please refer to User Manual - Appendix A.1 for pin assignments)

2.2.2 LAN: Ethernet Connector

UNO-137 is equipped with two Gigabit LAN controllers. An Intel® i210 Ethernet controller that complies with IEEE 802.3u 10/100/1000 Base-T is used as the controller chip. The Ethernet port is a standard RJ-45 jack. Additionally, LED indicators are provided on the front of the device to indicate the system's Link (off/green/orange) and Active (green) status. (Please refer to User Manual- Appendix A.2 for pin assignments.)

2.2.3 USB Connector

UNO-137 features 4x USB ports that comply with USB EHCI, 3 for Rev. 3.0, 1 for Rev. 2.0 specifications. The USB connectors support plug-and-play and hot-swapping functionality for external devices. Additionally, this can be enabled/disabled in the BIOS menu. (Please refer to User Manual- Appendix A.3 for pin assignments.)

2.2.4 Display Connector

The UNO-137 provides 2x DP 1.2 connector for a high resolution interface up to 4096 x 2306 @ 60Hz, It also supports DP++ that can be compatible with passive adapter. (Please refer to User Manual- Appendix A.4 for pin assignments.)

2.2.5 COM Connector

UNO-137 has 2 COM RS232/422/485 ports of terminal block type. They offer transmission speeds of 50 ~115.2 kbps.

The default mode for both COM ports (COM1&COM2)is RS-232 Mode. Settings can be adjusted via an on-board switch (SW1).

(Please refer to User Manual- Appendix A.8 for RS232/422/485 settings).

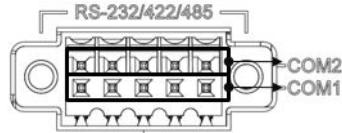
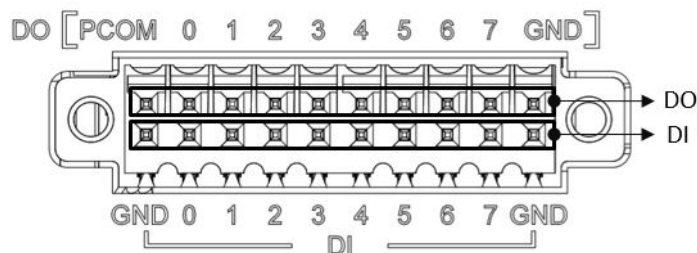

Table 2.2: COM Connector Pin Assignments

Pin	COM1 Mode	Signal Name	Pin	COM2 Mode	Signal Name
1	RS232	CTS	2	RS232	CTS
	RS422	T-		RS422	T-
	RS485	D-		RS485	D-
3	RS232	RXD	4	RS232	RXD
	RS422	T+		RS422	T+
	RS485	D+		RS485	D+
5	RS232	TXD	6	RS232	TXD
	RS422	R+		RS422	R+
	RS485			RS485	
7	RS232	RTS	8	RS232	RTS
	RS422	R-		RS422	R-
	RS485			RS485	
9	RS232	GND	10	RS232	GND
	RS422	GND		RS422	GND
	RS485	GND		RS485	GND

2.2.6 Digital Input and Output

There are 8x digital inputs and 8x digital outputs configured from GPIO pins for on/off triggering and status reading.



The following table indicates the mapping for DIO and GPIO

GPIO Pin	Pin 0	Pin1	Pin2	Pin3
DI Pin	DI0	DI1	DI2	DI3
GPIO Pin	Pin 4	Pin5	Pin6	Pin7
DI Pin	DI4	DI5	DI6	DI7
GPIO Pin	Pin 8	Pin9	Pin10	Pin11
DO Pin	DO0	DO1	DO2	DO3
GPIO Pin	Pin 12	Pin13	Pin14	Pin15
DO Pin	DO4	DO5	DO6	DO7

Use SW6 to set Wet Contact and Dry Contact for Digital input

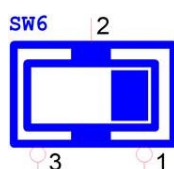

Dry: Configure to Setting 1 (Default)

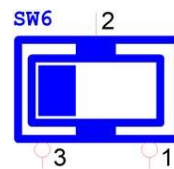

Wet: Configure to Setting 3

Digital Input

- Input Channels 8
- Input Voltage (Wet Contact), Configure SW6 to Setting 3
 - Logic 0: 10~30 V_{DC}
 - Logic 1: 0~3 V_{DC}
- Input Voltage (Dry Contact), Configure SW6 to Setting 1
 - Logic 0: Shorted to GND
 - Logic 1: Open
- Isolation Protection 2,500 V_{DC}
- Over-voltage Protection 30 V_{DC}
- Opto-Isolator Response 50 μs

Digital Output

- Output Channels 8
- Output Voltage: 5~30V_{DC}
- Output Capability Sink: 500 mA max./channel
- Opto-Isolator Response 50 μs

Isolated Digital Input

Each of the 8 x isolated digital input channels accept voltages from 0 to 30 V. The following figure shows how to connect an external input source to the isolated inputs of UNO-137.

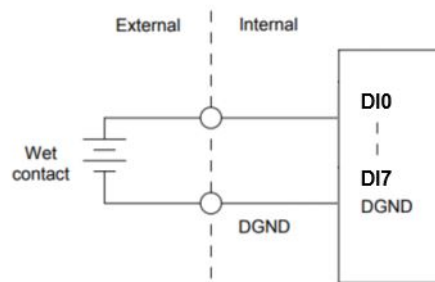

Figure 2.5 Isolated DI Wet Connection Diagram

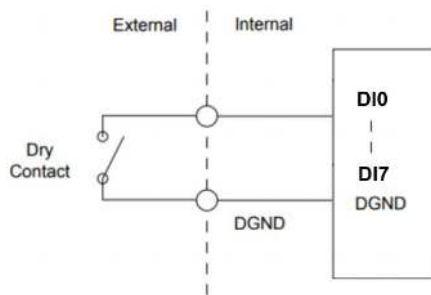

Figure 2.6 Isolated DI Dry Connection Diagram

Isolated Digital Output

If the external voltage source (5~30 V) is connected to each isolated digital output channel and its isolated digital output turns on (500 mA max./ ch), the board's current will sink from the external voltage source. The following figure shows how to connect an external output load to the isolated outputs on UNO-137.

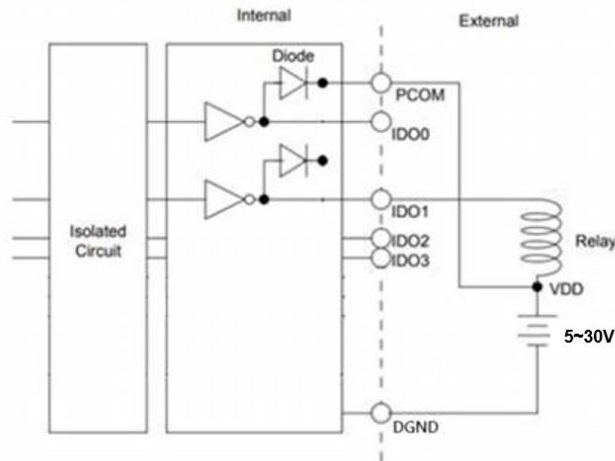

Figure 2.7 Isolated DO Connection Diagram

2.3 Internal I/O Connectors and Switches

The following figure demonstrates the locations of internal connectors and switches on the UNO-137's motherboard.

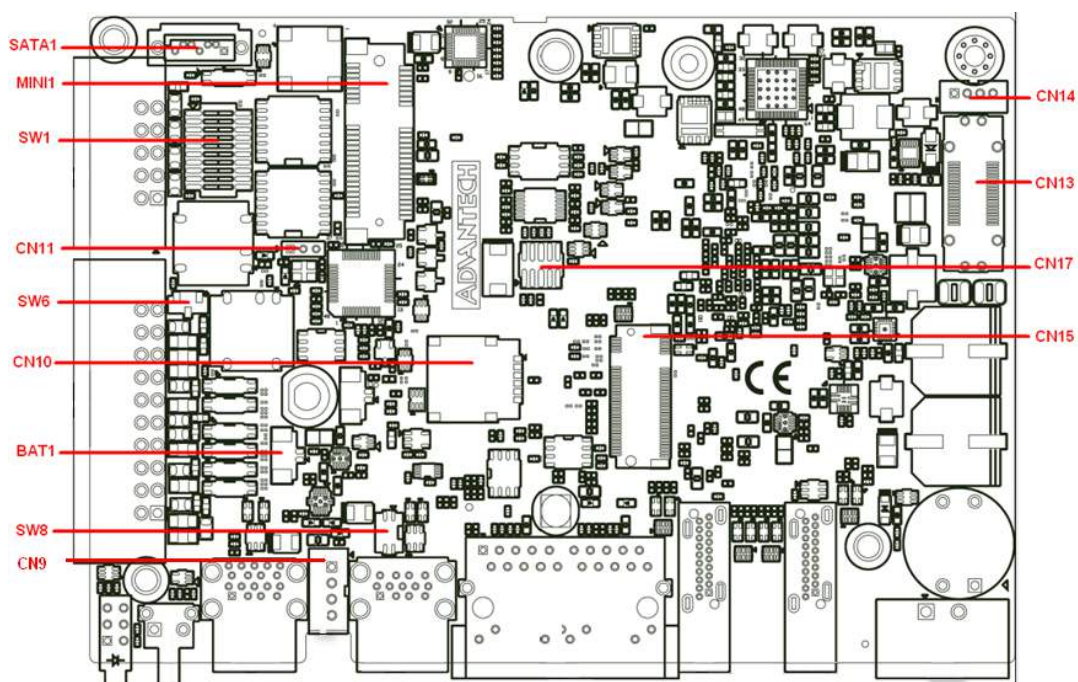

Figure 2.8 Locations Internal I/O Connectors/Switches for UNO-137

Table 2.3: Internal Connectors and Jumper Switches

Label	Function
MINI1	MiniPCIe Connector
CN15	M.2 B key for 2242/3042/3052 Connector
CN10	Nano SIM slot Connector
CN14*	iDoor Power Connector
SATA1	SATA Signal Connector
CN9	SATA Power Connector
CN13	Reserve for connector expansion
CN17	Debug Connector
CN11	Clear CMOS Connector
SW1	COM Port RS232/422/485 settings
SW6	DI Setting (Dry/Wet)
SW8	AT/ATX/Remote setting
BAT1	RTC Battery Connector

Note! *This power is from DC Power inputs



Configure the UNO-137 to match the needs of your application by setting switches, The following details the switch setting definitions:

Dip switch definition:
Bit 1: on

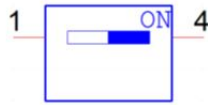

Bit 1: off

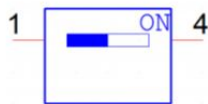

2.3.1 SATA Connector/SATA Power Connector

There're two required onboard connectors needed to connect with 2.5" SATA SSD/HDD. the location labeled "SATA1" is for SATA connector, and the location labeled "CN9" is for SATA power connector.

(Please refer to User Manual- Chapter 3.3 for installation details and User Manual- Appendix A.5 for pin assignments.)

2.3.2 M.2 Connector

There is one M.2 B Key connector for M.2 cards, labeled "CN15" on the board. This M.2 interface is a SATA signal co-lay with a USB signal. It will automatically detect which device you installed and determine the appropriate SATA or USB signal to use. Therefore, it supports the installation of M.2 2242 (w/SATA signal) or 3042/3052 module (w/ USB Signal).

(Please refer to User Manual- Chapter 3.3 & 3.5 for installation details and User Manual-Appendix A.6 for pin assignments.)

2.3.3 mPCIe Connector

There's one sockets for full size PCI Express mini cards, labeled "MINI1" on the board.

It supports iDoor module for diversified applications such as isolated COM port, Pro-fibus, WLAN GPRS, LTE, and MRAM. Users can install the iDoor easily with optional extension kit.

(Please refer to User Manual- Chapter 3.6 for extension kit installation details and UserManual-Appendix A.7 for pin assignments.)

2.3.4 Nano SIM Slot

There's one Nano SIM Slot for supporting LTE function, labeled "CN10" on board. In addition to install SIM card on "CN10", users are required to install a LTE Module on "CN15" M.2 B Key to enable the functionality.

2.4 Others

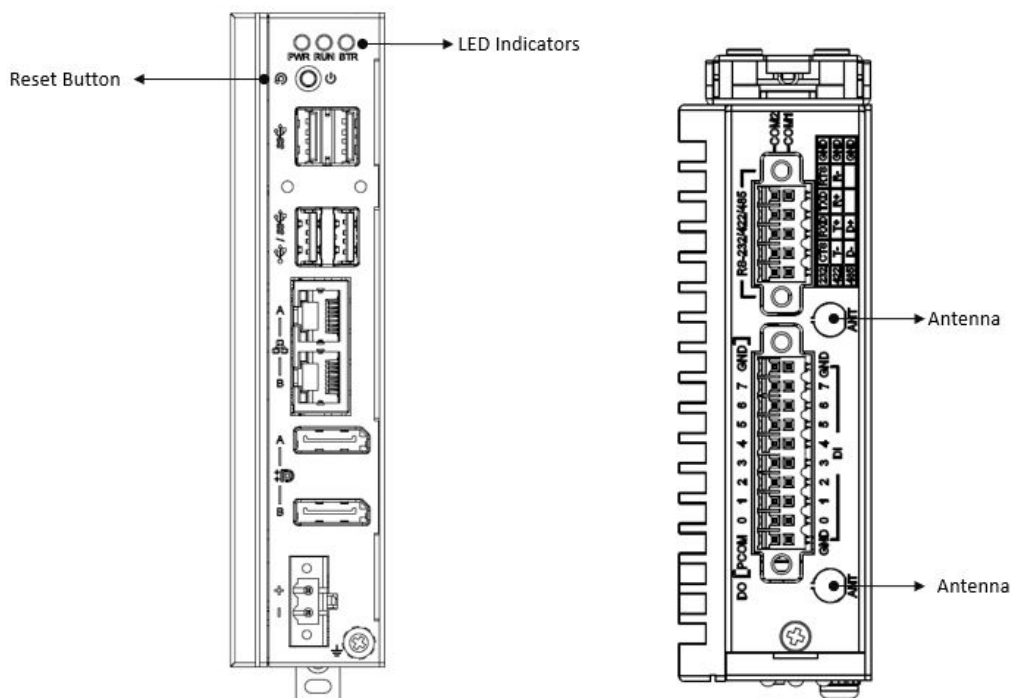

Figure 2.9 LED Indicators, Reset Buttons, and Antenna Hole

2.4.1 LED Indicators

Three LEDs indicate the status of the system’s power, RTC battery, and programmable LED for user’s configurations.

- PWR(Power): Green indicates “normal” and orange indicates “standby”.
- BTR(RTC Battery): Red indicates a low RTC battery. Check the RTC battery.
- RUN(Programmable): Users can configure the LED indicator’s behavior through GPO signal controls. Green indicates under programming.

2.4.2 Reset Buttons

Press the “Reset” button to initiate a hardware reset.

2.4.3 Antenna Hole

This product offers two antenna mounting holes covered by pre-cut holes for users to install an antenna kit for LTE or wireless functions.

Note! Please be aware of the Maximum OD value of the Antenna Hole when selecting antenna

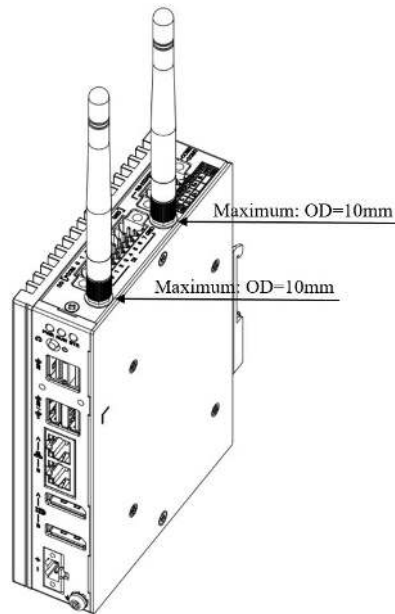

Figure 2.10 Diagram of Maximum OD Value for Antenna Hole

Chapter 3

Initial Setup

This chapter explains how to initialize the UNO-137

- Chassis Grounding
- Connecting Power
- Storage Installation (Optional)
- Din-Rail Installation
- Wireless Module Installation (Optional)
- Expansion Module Installation (Optional)
- Remote Power/On & Reset Setting
- BIOS Settings

3.1 Chassis Grounding

The UNO-137 provides good EMI protection and a stable grounding base. There is an easy-to-connect chassis grounding point.

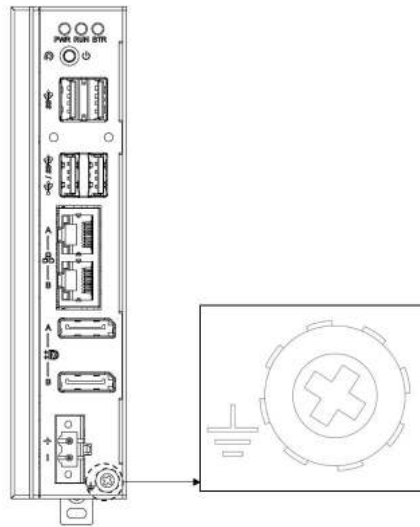

Figure 3.1 Chassis Grounding Connection Diagram

Use the Grounding cable (16 AWG) from the accessory bag to connect the chassis ground with the Earth ground.

3.2 Connecting Power

This product is intended to be supplied by an approved power adapter or DC power source. This adapter is rated at 10 - 36Vdc, 7.7-1.31A and has a Tmax of 70 °C (158 °F). If you need further assistance or information, please contact Advantech.

Note! *It is recommended to choose a 120W adapter when selected iDoor expansion module(e.g. PCM-24R2PE) is installed. Recommended PN: 96PSA-A120W19T2-3*



Follow the following instructions:

1. Insert the positive and negative wires into the V+ and V- contacts on the terminal block connector.
2. Tighten the wire-clamps' screws to prevent the DC wires from coming loose.

Take the following guidelines into consideration before wiring the device:

1. The terminal block is suitable for 12-24 AWG (12A). Torque value 7 lb-in. Use copper conductors only.
2. The temperature rating of the input connection cable should higher than 95 °C (203 °F)

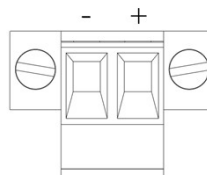

3.3 Storage Installation (optional)

UNO-137 supports the installation of one 2.5" HDD/ SSD and one M.2 2242 SSD. The installation is demonstrated in the following steps.

3.3.1 Installing a 2.5" HDD/SSD

1. Remove 2 screws from UNO's back cover.

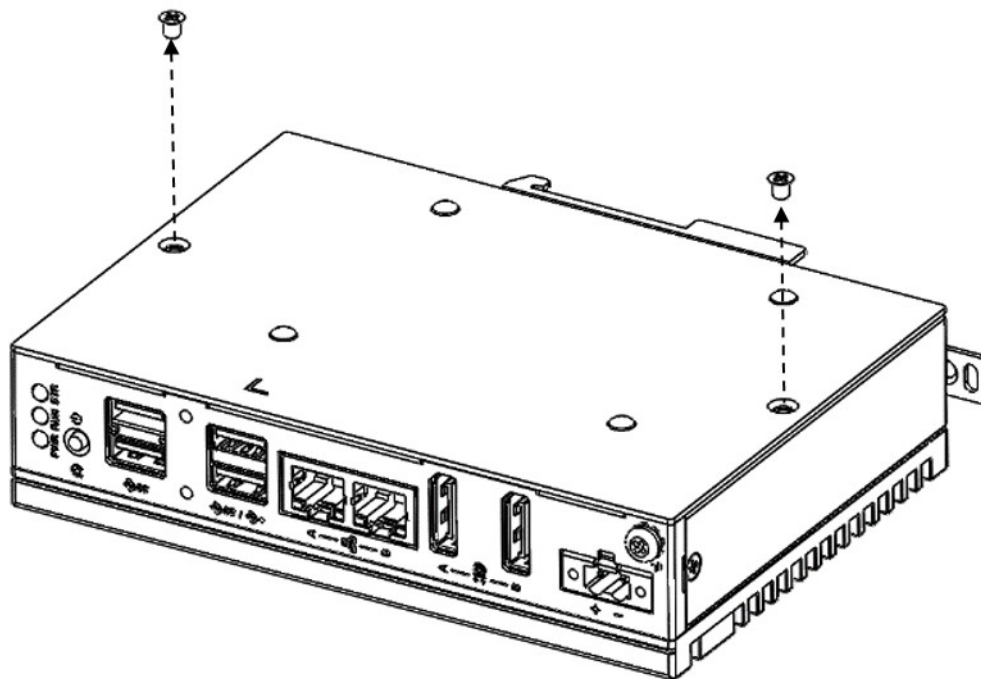

2. Remove the 4x plugs on the back cover, and secure the HDD/SSD with the 4 x M3x5L screws.

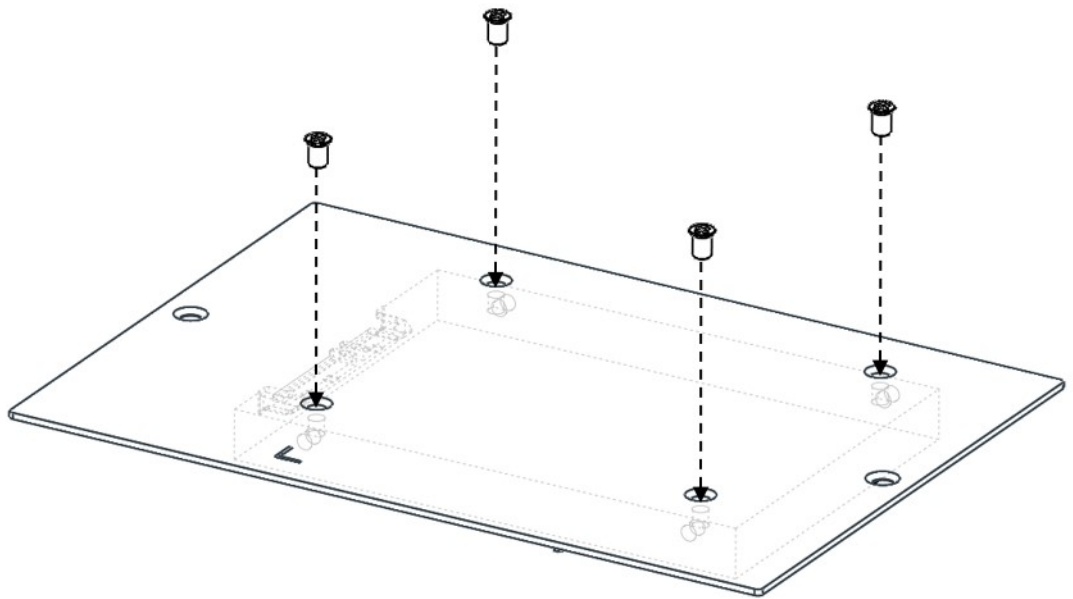
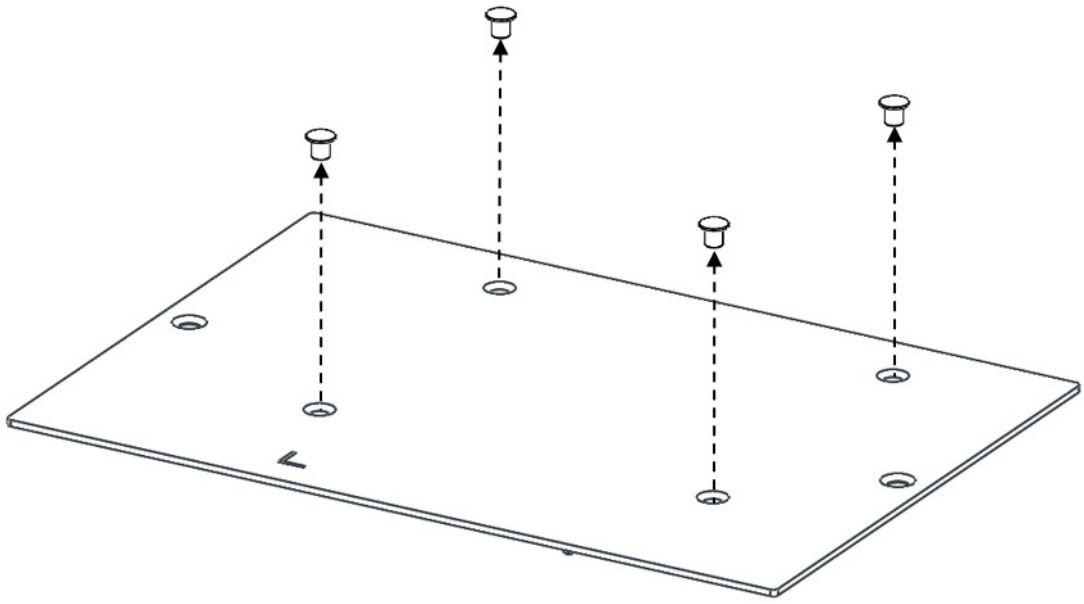

3. Plug in *SATA cable
 - (1) Plug in the SATA cable on the location: "SATA1", "CN9". Connect SATA cable with SSD/HDD.
 - (2) Fix the back cover with the provided screws from Step 1.

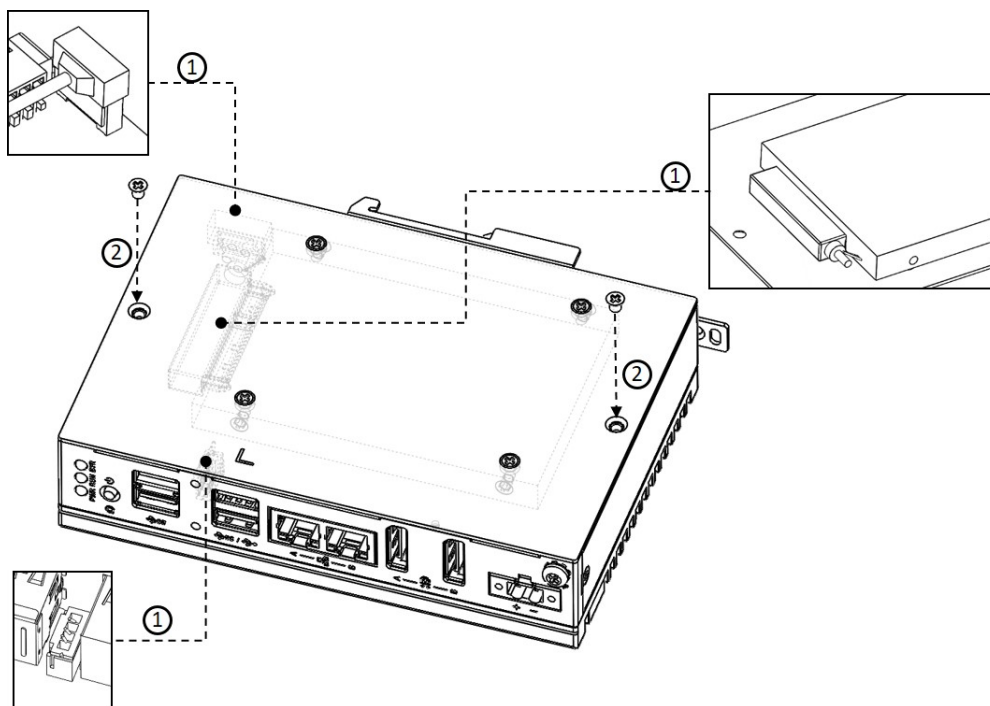

*4 x M3x5L screws, 1 x SATA cable are in accessory bag.

3.3.2 Installing M.2 SSD

1. Remove 2x screws from the back cover of UNO.
2. Remove the provided screws from the board.

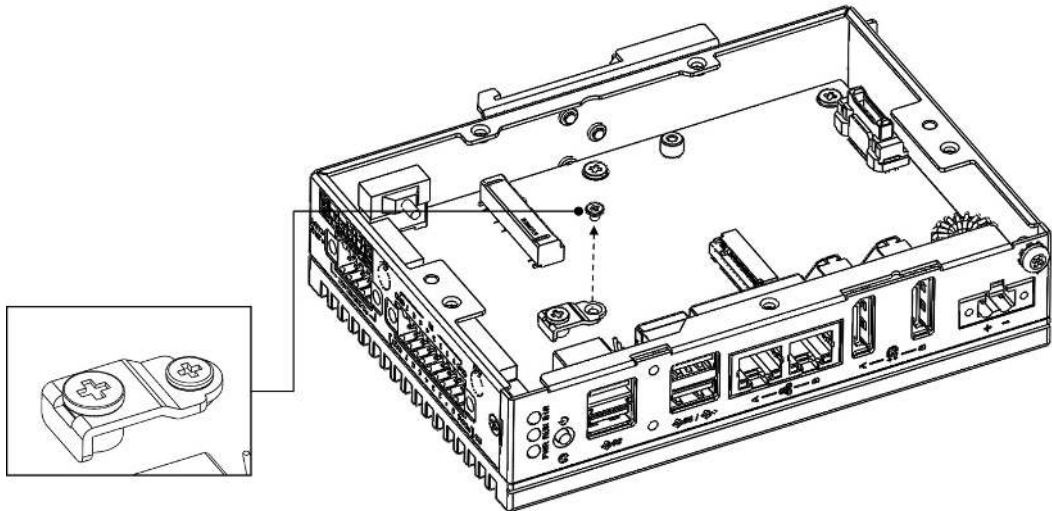

3. Insert the M.2 card on the location: "CN15". Secure it with the provided screws from Step 2.

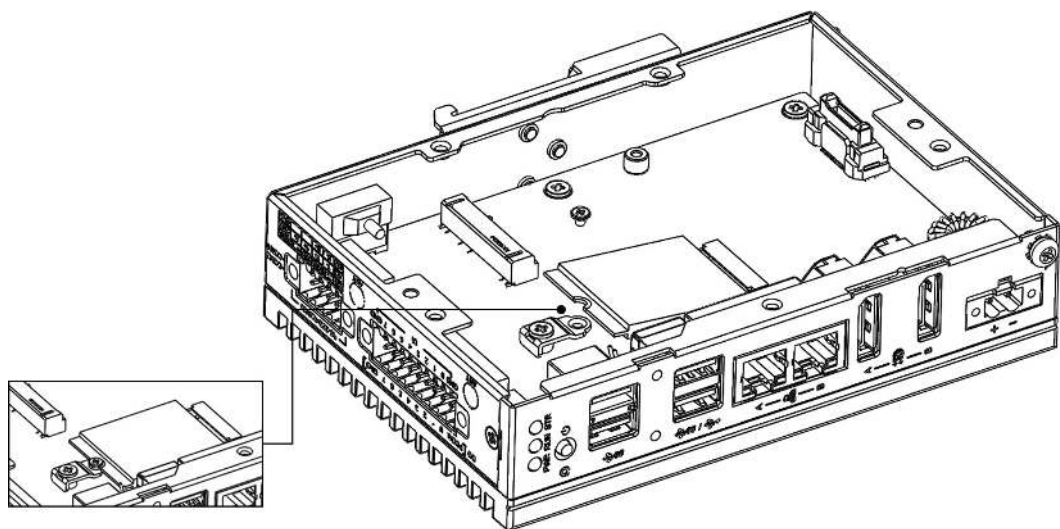

3.4 Din-Rail Installation

1. Install UNO-137 on the rail and secure it to the rail.

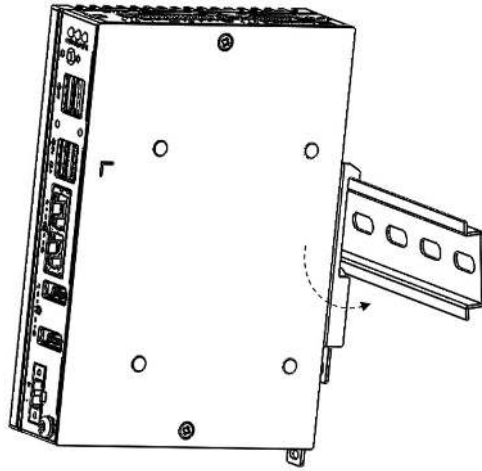

2. Pull down the "Release Latch" for disassembly using a screwdriver.

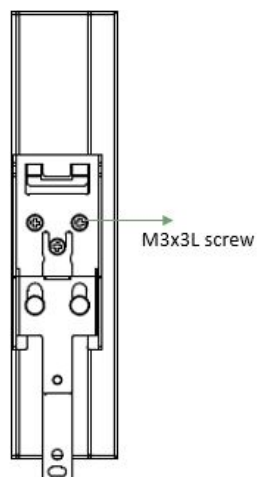
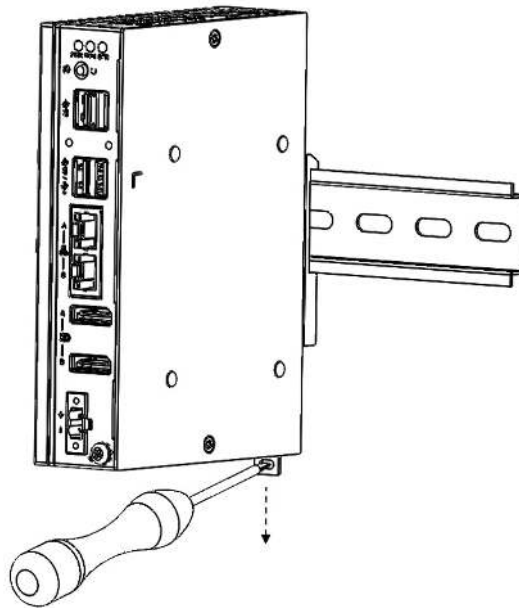

3.5 Wireless Module Installation (Optional)

UNO-137 supports to install WiFi iDoor/M.2 3042/M.2 3052 module. Follow the steps below for installation:

1. Remove 2 screws from back cover of UNO.
2. Remove the plug of antenna pre-cut hole(s) on the top panel for antenna installation

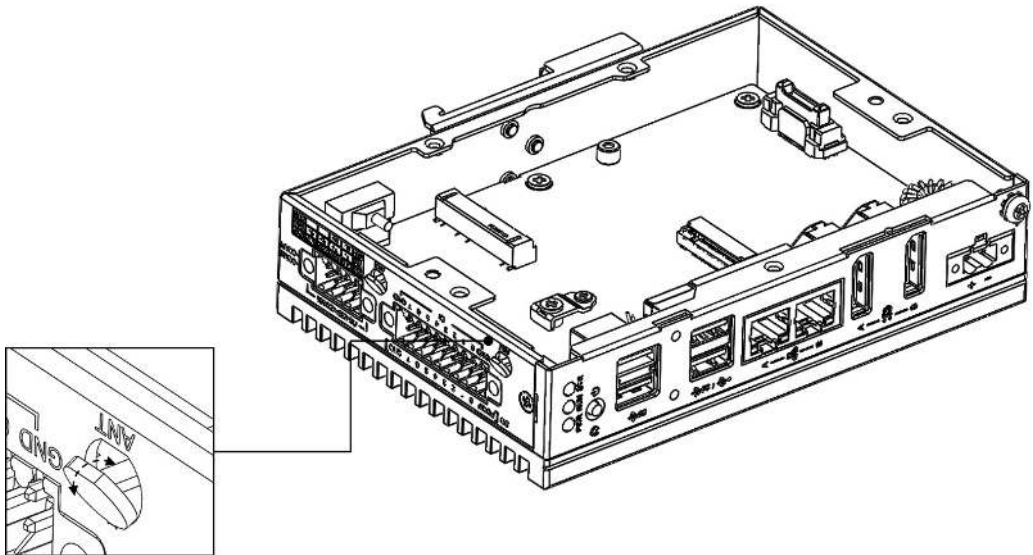

3. Plug the Module onto the board:
 - For *iDoor WiFi module: Please refer to 3.6 Extension Kit Installation for iDoor installation
 - For M.2 3042/M.2 3052 Module: Plug onto M.2 B Key connector (Location: CN15)
 - (1) Remove the provided screws from the board

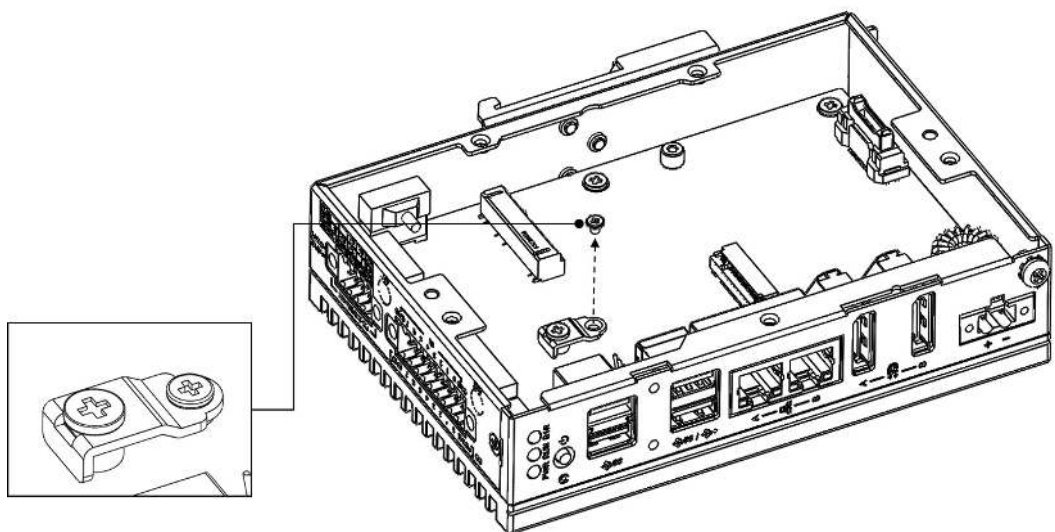

- (2) Insert the M.2 card to the location: "CN15" and secure it with the provided screws from Step 3-1

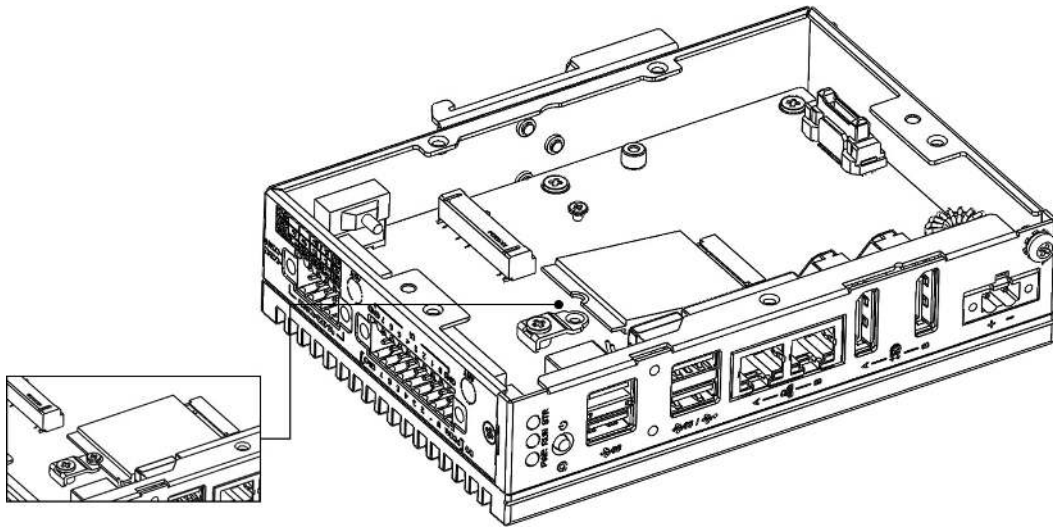

4. Install the SMA connector of *Antenna cable to the Antenna hole

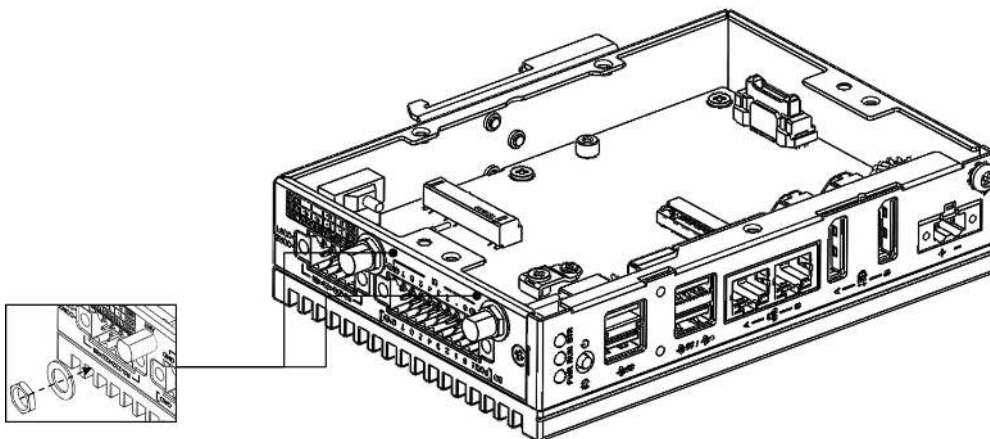

5. Connect the MHF of Antenna cable with module
6. Return the back cover and gently screw it into place

7. Assemble the *Antenna on the SMA connector of the Antenna cable

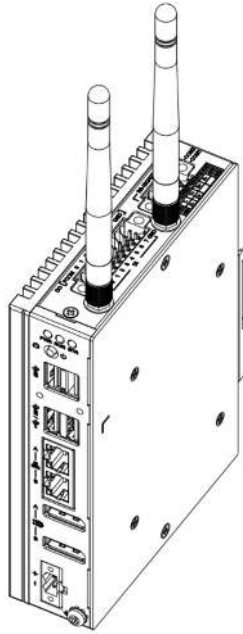

*Wireless Module, Antenna cable, Antennas are optional, please contact Advantech for further information.

Note! If you need to install M.2 3052 Module, please follow the following steps



1. Remove the on-board “bracket”

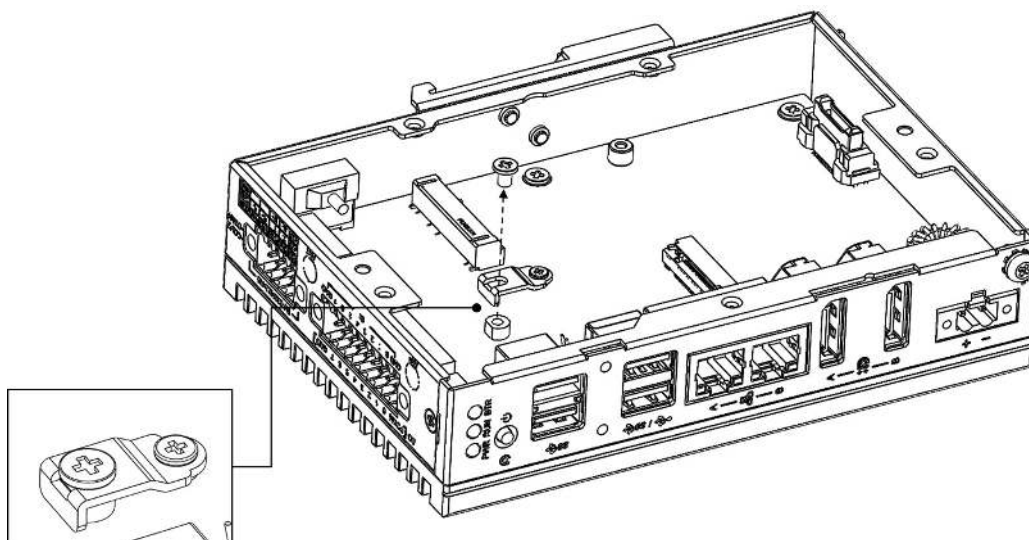

2. Use the provided screws from Step1 to fix the M.2 3052 module

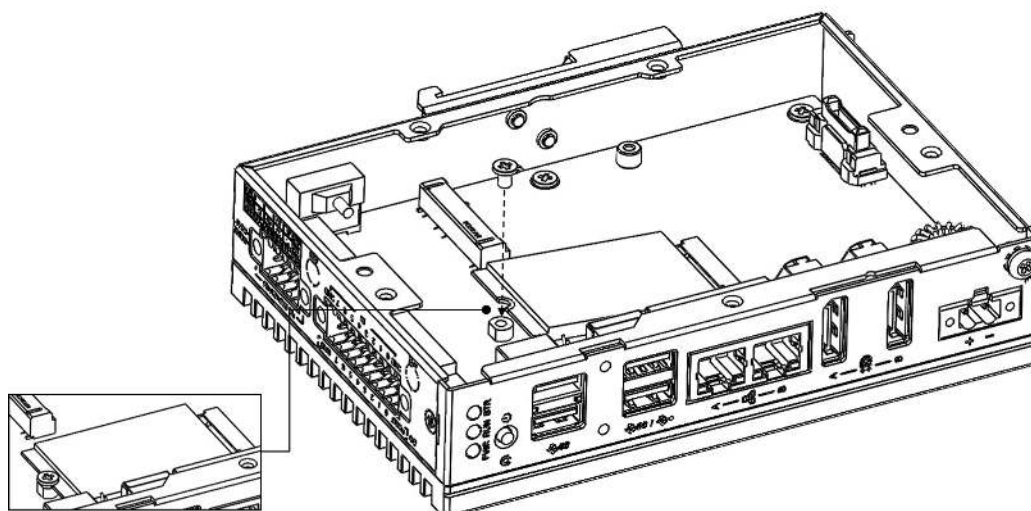

3.6 Extension Kit Installation (Optional)

You can additionally install 2nd stack iDoor extension kit (PN:UNO-137-ID1EA) on UNO-137 to expand its functionality:

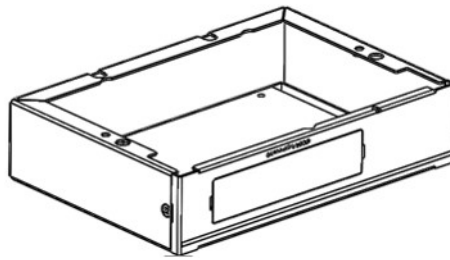

The accessory list for iDoor extension kit (PN:UNO-137-ID1EA)

5 x M3x4L screws for extension kit installation

4 x M3x4L screws for HDD installation

Follow the steps below for extension kit Installation:

1. Remove 2 screws from back cover of UNO-137.

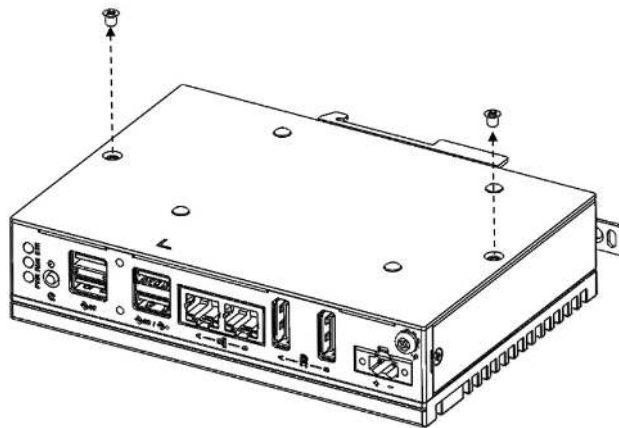

2. Detach the iDoor dummy cover from the iDoor extension kit.

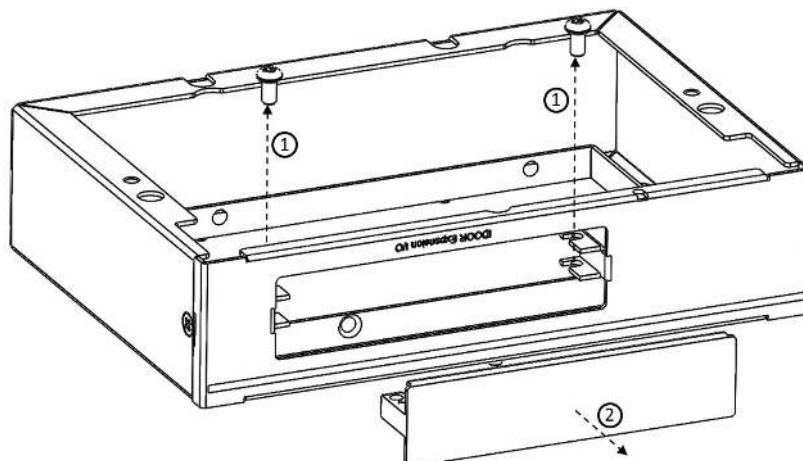

3. Install and secure the iDoor module with the provided screws from Step 2

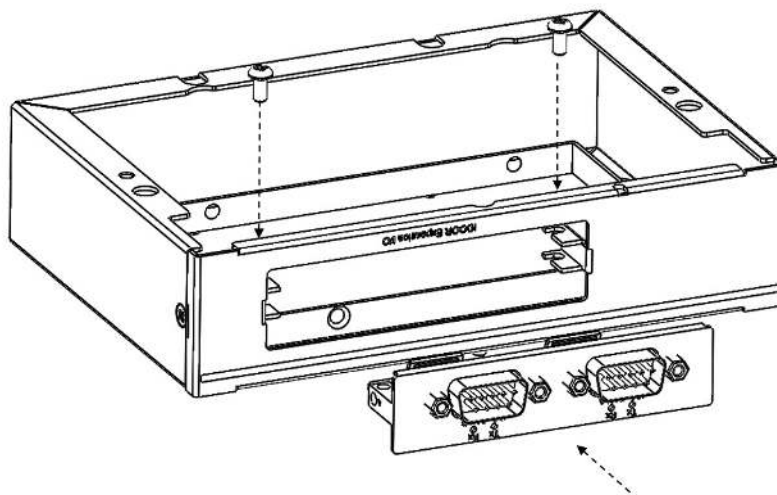

4. Extension Kit Installation:
 - (1) Connect the mPCIe connector of iDoor module onto the board of UNO-137, and fix it with the M2x4L screw from the accessory bag of UNO-137
 - (2) Fix iDoor extension kit onto UNO-137 with 5 x M3x4L screws from its accessory bag

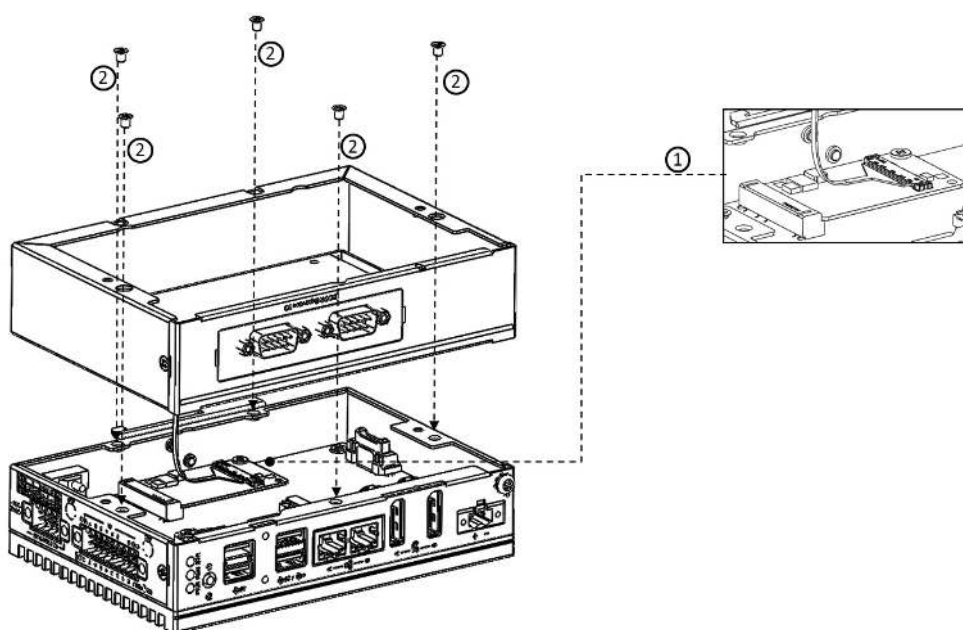

5. Return the back cover of UNO-137 with the provided screws from Step 1

Note! When installing 2nd stack extension kit (UNO-137-ID1EA), the 2.5" HDD/SSD installation instructions are changed as below.



1. Detach the HDD bracket from 2nd stack extension kit, then fix the 2.5" HDD/SSD to the HDD bracket with the 4 x M3x4L screws from the accessory bag of iDoor extension kit

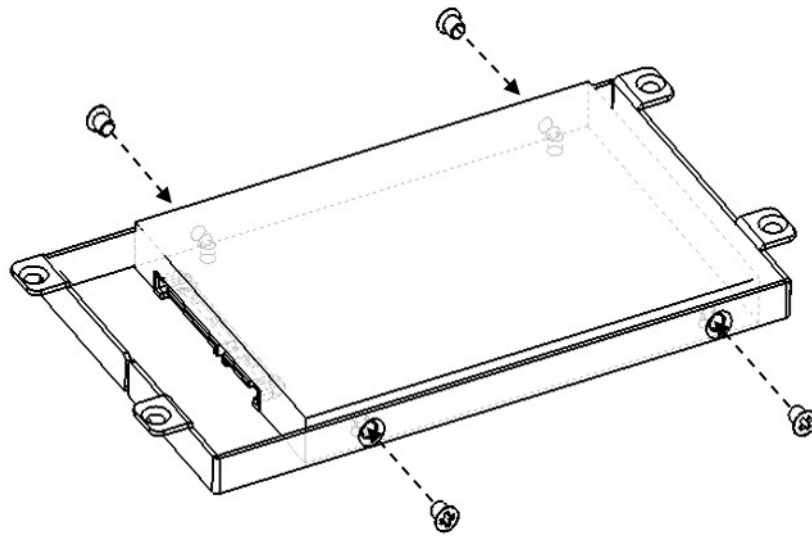

2. Fix the HDD bracket back onto the extension kit with the provided screws from step 1.

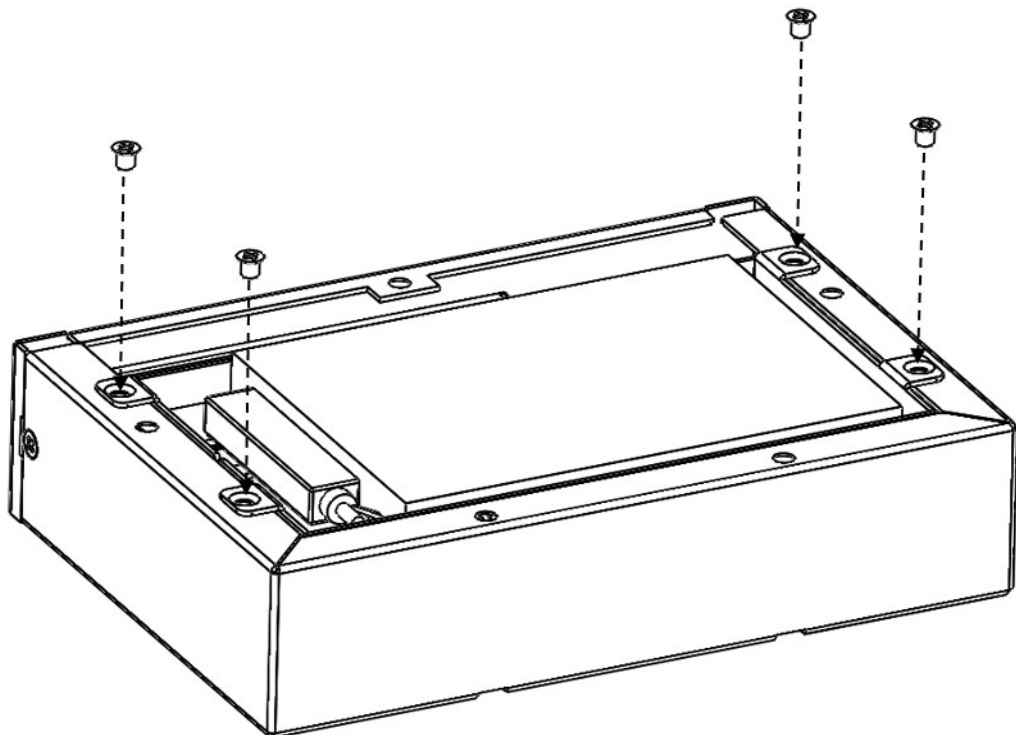

3. Extension Kit installation:
 - (1) Plug in SATA cable onto the board of UNO-137 and connect with SSD/HDD.
 - (2) Fix extension kit onto UNO-137 with 5 x M3x4L screws from its accessory bag

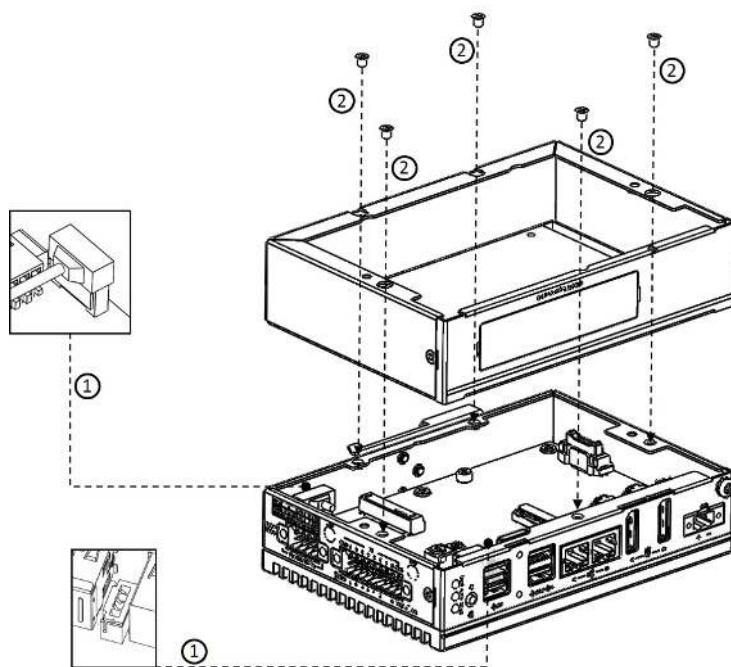

4. Return the back cover of UNO-137.

3.7 Remote Power & Reset Settings

UNO-137 supports remote power & reset functions through DI connector with the switch setting (SW8) on the motherboard. The default setting is for DI6/DI7 functionality. If you want to configure UNO-137 for remote control functions, configure SW8-Bit 2 to “on”, then DI6 can be used for remote power settings, and DI7 can be used for remote reset setting.

Table 3.1: Remote Power/On & Reset Settings



Description	Instruction	SW8
DI function for DI6/ DI7(Default)	Bit 2 off	
Remote Setting Function	Bit 2 on	

3.8 BIOS Setting

With the BIOS Setup program, you can modify BIOS settings and control the special features of your computer. The Setup program uses a number of menus for making changes and turning special features on or off.

Press the “ESC” key upon the first boot up to enter the BIOS setup screen, after then, press the “Del” key during the Power On Self Test (POST) process to enter the BIOS setup screen, otherwise the system will continue the POST process.

(Please refer to User Manual- Appendix A.11/ A.12 for more settings)

Appendix **A**

System Settings/Pin
Assignments

A.1 Power Connector (CN1)

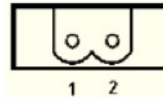

Table A.1: Power Connector Pin Assignments

Pin	Signal	Description
1	Power IN V+	10 - 36 V _{DC}
2	Power IN V- (GND)	

A.2 LAN: Ethernet Connector (CN4)

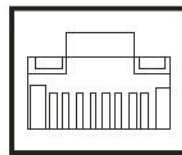

Table A.2: Ethernet Connector Pin Assignments

RJ45 Pin	Signal	Description
1	MDI0+	<ul style="list-style-type: none"> ■ In BASE-T: Media Dependent Interface[0]: ■ 1000BASE-T: In MDI configuration, MDI[0]+/- corresponds to BI_DA+/- and in MDI-X configuration MDI[0]+/- corresponds to BI_DB+/-. ■ 10BASE-T and 100BASE-TX: In MDI configuration, MDI[0]+/- is used for the transmit pair and in MDIX configuration MDI[0]+/- is used for the receive pair.
2	MDI0-	
3	MDI1+	<ul style="list-style-type: none"> ■ In BASE-T: Media Dependent Interface[1]: ■ 1000BASE-T: In MDI configuration, MDI[1]+/- corresponds to BI_DB+/- and in MDI-X configuration MDI[1]+/- corresponds to BI_DA+/-. ■ 10BASE-T and 100BASE-TX: In MDI configuration MDI[1]+/- is used for the receive pair and in MDI-X configuration MDI[1]+/- is used for the transmit pair.
6	MDI1-	
4	MDI2+	<ul style="list-style-type: none"> ■ In BASE-T: Media Dependent Interface[3:2]: ■ 1000BASE-T: In MDI and in MDI-X configuration, MDI[2]+/- corresponds to BI_DC+/- and MDI[3]+/- corresponds to BI_DD+/-. ■ 100BASE-TX: Unused. ■ 10BASE-T: Unused.
5	MDI2-	
7	MDI3+	
8	MDI3-	

Left LED		Right LED	
10Link	100 Link	1000 Link	Active
Off	Orange	Green	Green

A.3 USB Connector (CN5,CN6)

A.3.1 USB 2.0 Connector

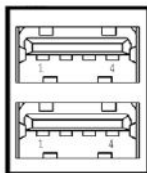

Table A.3: Connector Pin Assignments

Pin	Signal Name	Description
1	VBUS	Power
2	D-	USB2.0 differential pair
3	D+	
4	GND	Ground for power return

A.3.2 USB 3.0 Connector

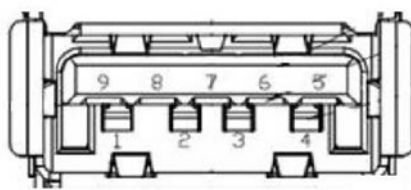

Table A.4: USB 3.0 Connector Pin Assignments

Pin	Signal Name	Description
1	VBUS	Power
2	D-	USB 2.0 differential pair
3	D+	
4	GND	Ground for power return
5	StdA_SSRX-	SuperSpeed receiver differential pair
6	StdA_SSRX+	
7	GND_DRIAN	Ground for signal return
8	StdA_SSTX-	SuperSpeed transmitter differential pair
9	StdA_SSTX+	

A.4 Display Connector (CN2,CN3)

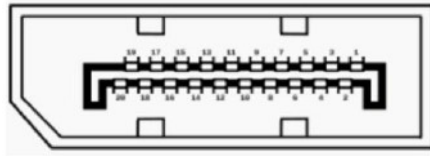

Table A.5: Display Port Adapter cable Pin Assignments

Pin	Signal Name
1	ML_Lane 0 (p)
2	GND
3	ML_Lane 0 (n)
4	ML_Lane 1 (p)
5	GND
6	ML_Lane 1 (n)
7	ML_Lane 2 (p)
8	GND
9	ML_Lane2 (2)
10	ML_Lane 3 (p)
11	GND
12	ML_Lane 3 (n)
13	CONFIG1
14	CONFIG2
15	AUX CH (p)
16	GND
17	AUX CH (n)
18	Hot Plug
19	Return
20	DP_PWR

A.5 SATA Connector/ SATA Power Connector

A.5.1 SATA Connector (SATA1)

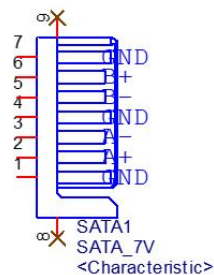

Table A.6: SATA Connector Pin Assignments

Pin	Signal Name
1	GND
2	SATA0_C_TX+
3	SATA0_C_TX-
4	GND
5	SATA0_RX-
6	SATA0_RX+
7	GND

A.5.2 SATA Power Connector (CN9)

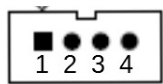

Table A.7: SATA Power Connector Pin Assignments

Pin	Signal Name	Description
1	+V5SATA	Power
2	GND	Ground for power return
3	GND	Ground for power return
4	NC	Reserved

A.6 M.2 Connector (CN15)

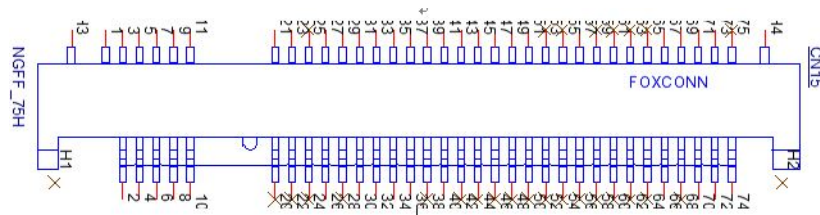

Table A.8: M.2 B Key Connector Pin Assignments

Pin	Signal Name	Pin	Signal Name
1	M2_SATA1_DET	2	+V3.3_M2
3	GND	4	+V3.3_M2
5	GND	6	M2_LTE_PWR_OFF#
7	M2_LTE_USB_DP	8	M2_LTE_W1_DISABLE_N
9	M2_LTE_USB_DN	10	+V3.3_M2
11	GND	12	Mechanical notch B
13	Mechanical notch B	14	Mechanical notch B
15	Mechanical notch B	16	Mechanical notch B
17	Mechanical notch B	18	Mechanical notch B
19	Mechanical notch B	20	NC
21	NC	22	NC
23	WAKE_ON_WAN#	24	NC
25	NC	26	M2_LTE_W2_DISABLE_N
27	GND	28	NC
29	USB_Z_SSRX1-	30	M2_SIM1_RESET
31	USB_Z_SSRX1+	32	M2_SIM1_CLK
33	GND	34	M2_SIM1_DATA
35	USB_C_SSTX1-	36	M2_SIM1_PWR
37	USB_C_SSTX1+	38	NC
39	GND	40	M2_SIM2_DET
41	SATA1_RX+	42	NC
43	SATA1_RX-	44	NC
45	GND	46	NC
47	SATA1_C_TX-	48	NC
49	SATA1_C_TX+	50	NC
51	GND	52	NC
53	NC	54	NC
55	NC	56	NC
57	GND	58	NC
59	NC	60	NC
61	NC	62	NC
63	NC	64	NC
65	NC	66	M2_SIM1_DET
67	LTE_RST#_P67	68	NC
69	NC	70	+V3.3_M2
71	GND	72	+V3.3_M2
73	GND	74	+V3.3_M2
75	NC		

A.7 mPCIe Connector (MINI1)

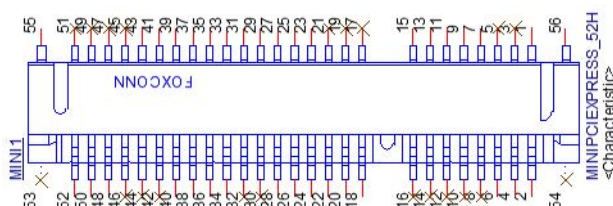

Table A.9: mPCIe Connector Pin Assignments

Pin	Signal Name	Pin	Signal Name
1	PCIE_WAKE#_3.3	2	+V3.3_MINI
3	NC	4	GND
5	NC	6	+V1.5
7	+V3.3	8	NC
9	GND	10	NC
11	CLK_PCIE_mPCIe1-	12	NC
13	CLK_PCIE_mPCIe1+	14	NC
15	GND	16	NC
17	NC	18	GND
19	NC	20	WIFI_DISABLE#
21	NC	22	MINI_PLTRST#
23	PCIE_mPCIe_RX4-	24	+V3.3_MINI
25	PCIE_mPCIe_RX4+	26	GND
27	GND	28	+V1.5
29	GND	30	NC
31	PCIE_TX2-_Z	32	NC
33	PCIE_TX2+Z	34	GND
35	GND	36	USB_Z_P0-
37	GND	38	USB_Z_P0+
39	+V3.3_MINI	40	GND
41	+V3.3_MINI	42	NC
43	MPCIe_PWRSEL	44	NC
45	NC	46	NC
47	NC	48	+V1.5
49	NC	50	GND
51	NC	52	+V3.3_MINI

A.8 COM Port RS232/422/485 Settings

The default setting for the COM port is RS-232. This can be changed to RS-422 or RS-485 modes can be configured by adjusting switch on the motherboard.

A.8.1 RS232/422/485 Setting (SW1)

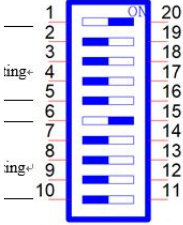
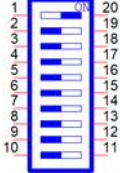
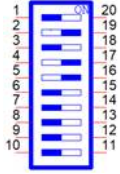
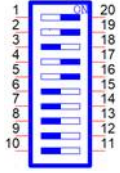
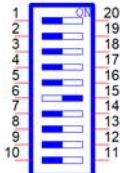
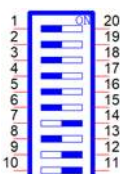
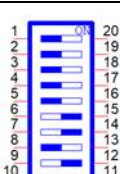

SW1 Default		
Description	This switch is used to select RS232/422/485 mode settings	
Default	RS232 mode	
RS232 Mode	Bit 1 ON Bit 2,3,4,5,6,7,8,9,10 OFF	
COM1 RS485 Mode	Bit 2,4,5 ON Bit 1,3,6,7,8,9,10 OFF	
RS422 Mode	Bit 1,2,4,5 ON Bit 3,6,7,8,9,10 OFF	
RS232 Mode	Bit 6 ON Bit 1,2,3,4,5,7,8,9,10 OFF	
COM2 RS485 Mode	Bit 7,9,10 ON Bit 1,2,3,4,5,7,8 OFF	
RS422 Mode	Bit 6,7,9,10 ON Bit 1,2,3,4,5,8 OFF	

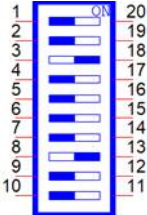
A.8.2 COM Port RS422/485 Termination Resistor Setting

SW1	Termination Resistor setting	
Description	This switch is used to select Termination Resistor (120 ohm) for long distance transmissions or device matching.	
Default	Bit3 off & Bit8 off	
COM1	Bit3 on	
COM2	Bit8 on	

A.9 AT/ATX Setting (SW8)

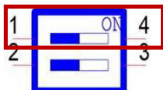
SW8 can be used for AT/ATX setting. The default setting is AT mode. See the following table for switch configuration.

SW8 Default		
Description	Instruction	SW8
AT Mode (Default)	Bit 1 off	
ATX Mode	Bit 1 on	

A.10 Board to Board Connector (Reserved for Expansion) (CN13)

Table A.10: Expansion Board to Board Connector Pin Assignments

Pin	Signal Name	Pin	Signal Name
1	eDP_HPDP#	2	GND
3	eDP_TX0+	4	eDP_TX0-
5	GND	6	eDP_TX1+
7	eDP_TX1-	8	GND
9	eDP_AUX+	10	eDP_AUX-
11	GND	12	PLTRST_B2B#
13	PMU_SLP_S3#	14	eDP_VDDEN_1V8
15	eDP_BKLTEN_1V8	16	eDP_BKLCTL_1V8
17	EC_LVDS_BKLT_EN	18	EC_LVDS_BKLT_CTL
19	ouch_EN_1V8	20	PCIE_WAKE#_3.3
21	GND	22	CLK_PCIE_mPCIe0+
23	CLK_PCIE_mPCIe0-	24	GND
25	PCIE_TX2+	26	PCIE_TX2-
27	GND	28	PCIE_RX2+
29	PCIE_RX2-	30	GND
31	NC	32	NC
33	GND	34	NC
35	NC	36	GND
37	USB2_P2+	38	USB2_P2-
39	GND	40	PCIE_MINI1_CLKREQ#

A.11 TPM 2.0 BIOS Setting

The UNO-137 systems support TPM 2.0 functionality. This can be enabled or disabled in the BIOS menu by following the instructions provided below:

1. Power on the UNO-137 system and press “Delete” to enter the BIOS configuration menu.
2. On the “Advanced” tab, select the “Trusted Computing” item.

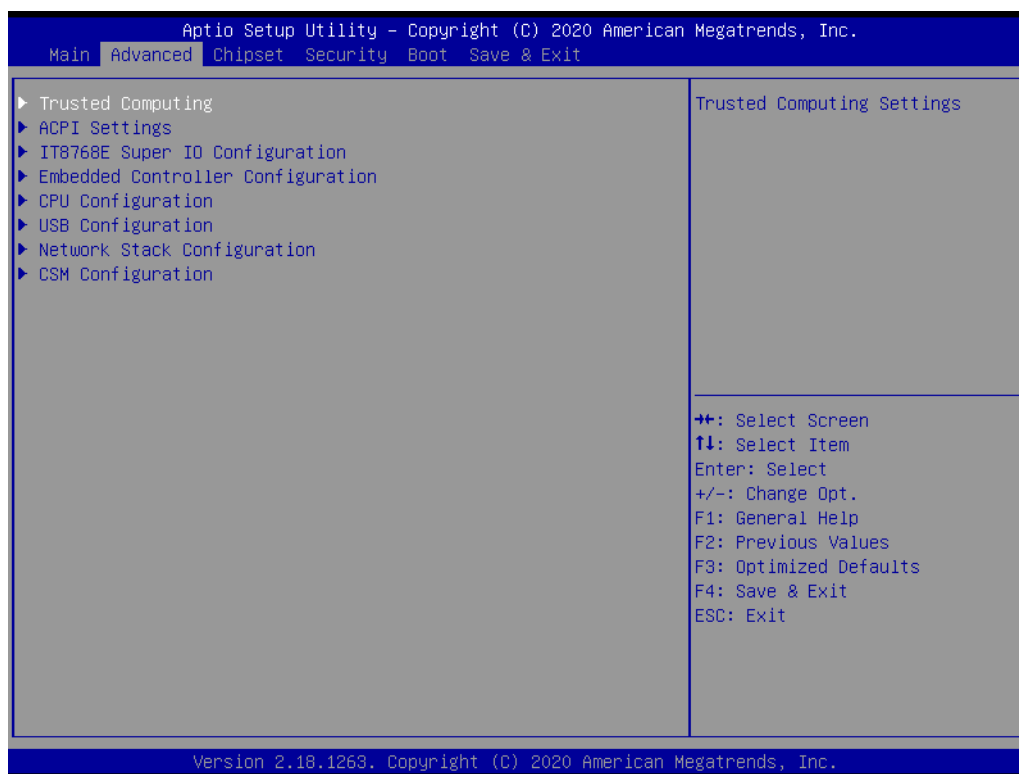

3. Then select the “Security Device Support” item.
4. Choose “enable/disable” to enable or disable the TPM 2.0 function (The default setting is to disable this function)

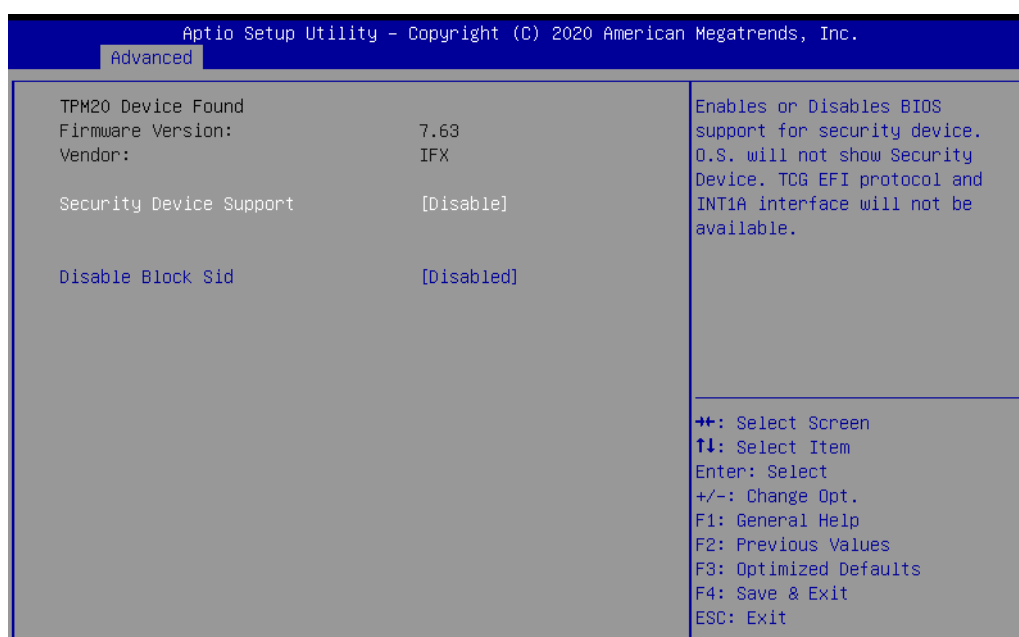

A.12 CPU Turbo Mode BIOS Setting

The UNO-137 systems support CPU Turbo mode. This can be enabled or disabled in the BIOS menu by following the instructions :

1. Power on the UNO-137 system and press “Delete” to enter the BIOS configuration menu.
2. On the “Advanced” tab, select the “CPU Configuration” item.

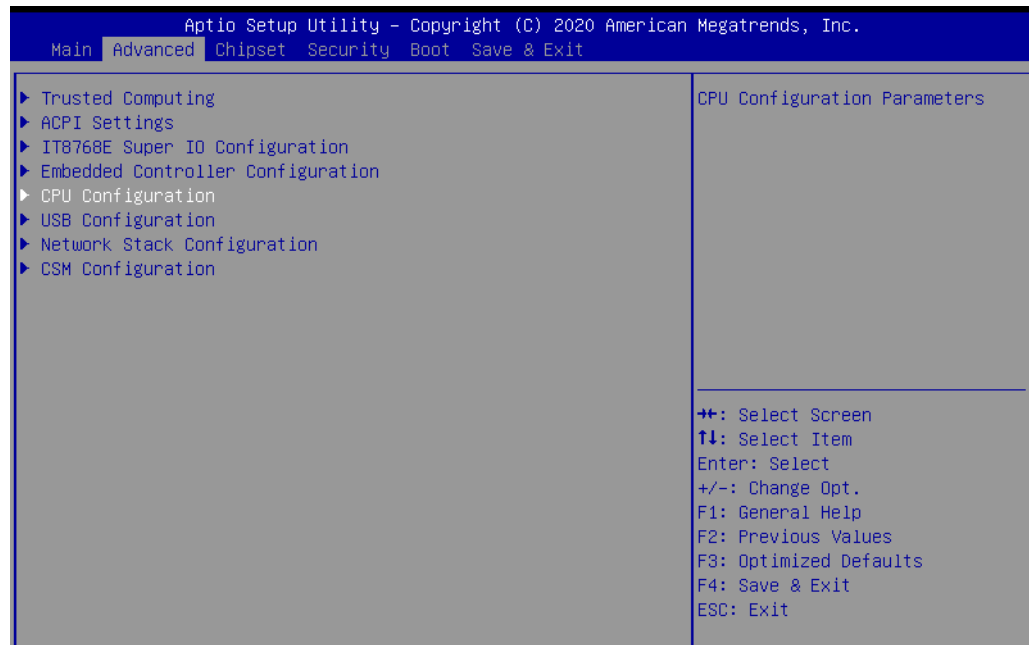

3. Then select the “CPU Power Management” item.

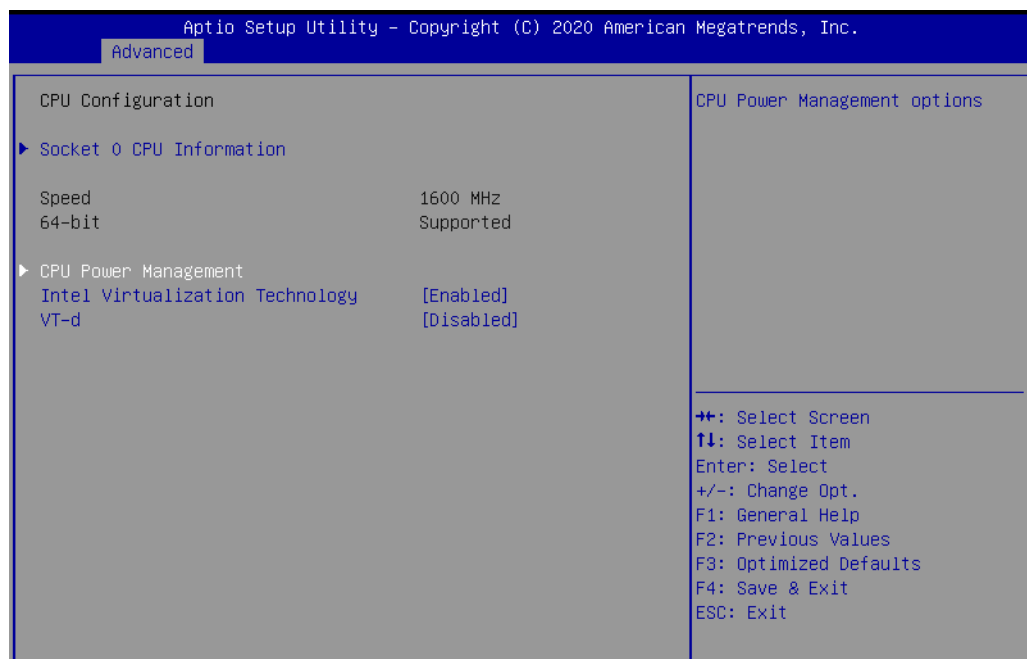

4. Choose “enable/disable” to enable or disable the CPU Turbo mode (The default setting is to disable this function)

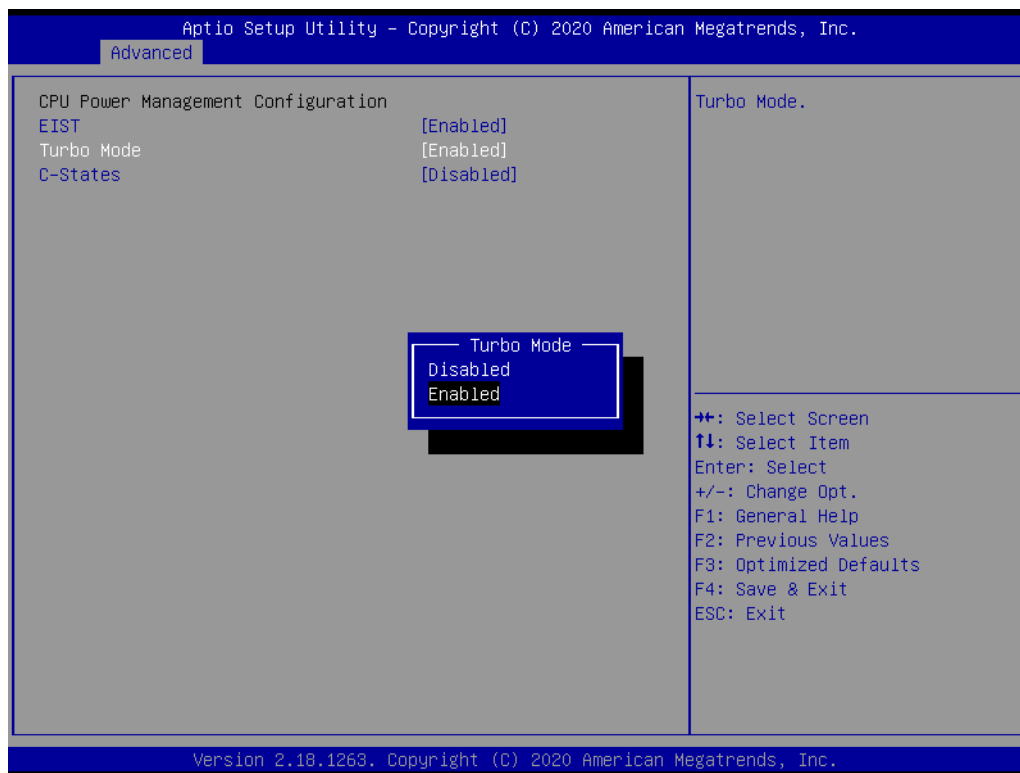

ADVANTECH

eAutomation

www.advantech.com

Please verify specifications before quoting. This guide is intended for reference purposes only.

All product specifications are subject to change without notice.

No part of this publication may be reproduced in any form or by any means, electronic, photocopying, recording or otherwise, without prior written permission from the publisher.

All brand and product names are trademarks or registered trademarks of their respective companies.

© Advantech Co., Ltd. 2020