

## EnerChip™ EP Universal Energy Harvester Eval Kit

### Features

CBC-EVAL-09 is a universal energy harvesting (EH) evaluation kit that combines any one of multiple EH transducers with the EnerChip™ EP CBC915-ACA Energy Processor and the EnerChip CBC51100 100uAh solid state battery module that has two 50uAh EnerChip solid state batteries connected in parallel. The purpose of this evaluation platform is to enable designers to quickly develop Energy Harvesting applications. The EVAL-09 ships with a solar cell for initial evaluation kit testing. A photo of CBC-EVAL-09 board is shown in Figure 1.

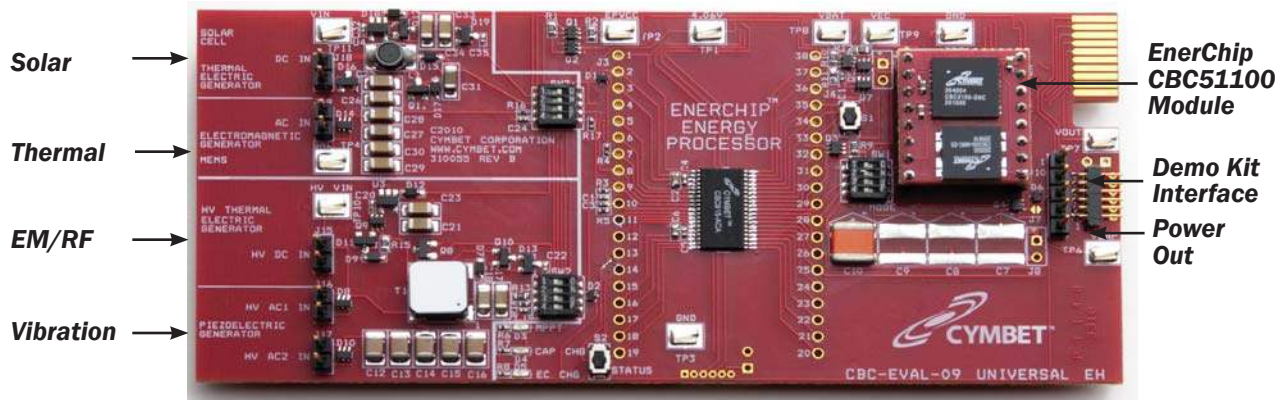

Figure 1: CBC-EVAL-09 Demo Kit - 5 x 2 inches

### System Description

There are several new technology advances on the EVAL-09: the ability to use any type of EH transducer, the EnerChip Energy Processor that uses high energy efficiency Maximum Peak Power Tracking algorithms, and EnerChip Solid State Batteries for energy storage when the EH transducer is inactive.

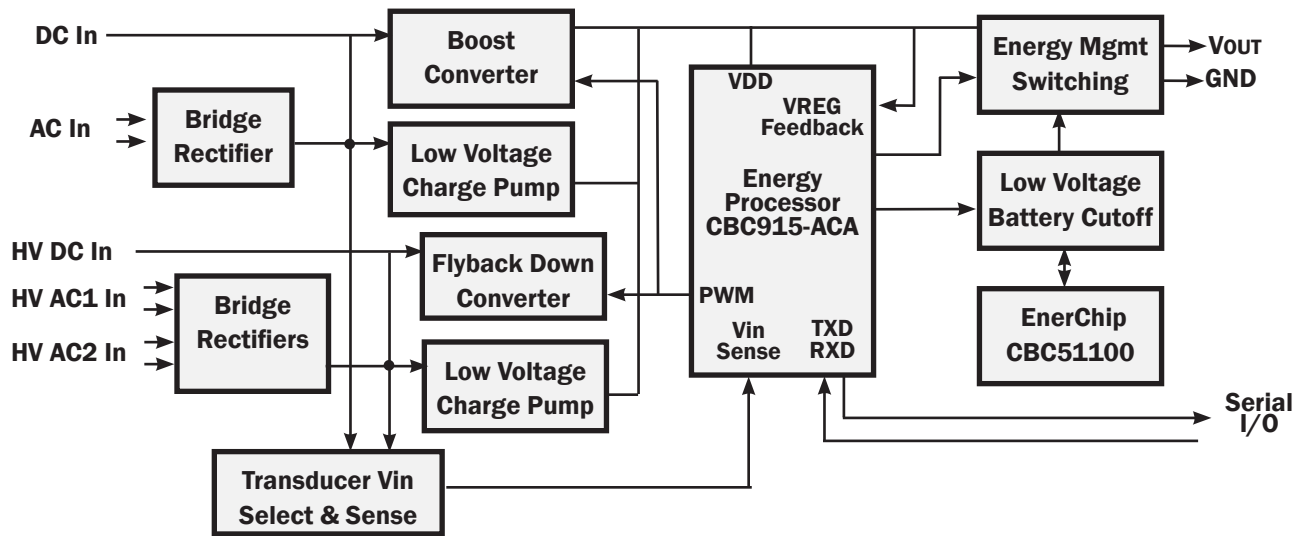

Figure 2: EnerChip CBC-EVAL-09 Demo Kit Block Diagram, with the CBC51100 EnerChip 100uAh Module

# CBC-EVAL-09 EnerChip EP Universal EH Eval Kit

---

## EVAL-09 Block Diagram Explanations

This section describes the EVAL-09 functional blocks shown in Figure 2.

**DC IN** - Energy Harvesting transducer input below 4.06V DC. Normally a photovoltaic cell.

**AC IN** - Energy Harvesting transducer input below 4.06V AC. An example might be an electromagnetic input from a flow harvester.

**HV DC IN** - Energy Harvesting constant impedance transducer input from 4.06V DC to 20VDC. Normally a photovoltaic cell or higher voltage thermoelectric generator.

**HV AC1 IN and HV AC2 IN** - Energy Harvesting transducer input from 4.06V DC to 20V AC. Normally a piezoelectric vibrational harvester. A single input can be utilized on HV AC1. If two piezo electric beams are mechanically coupled together in the same transducer unit, the two outputs can be connected to HV AC1 and HV AC2.

**Bridge Rectifiers** - Rectifies from AC to DC for AC In or HV AC IN.

**Boost Converter** - Boosts the DC In or AC IN voltage to 4.06 Volts.

**Low Voltage Charge Pumps (2)** - Used to start up the CBC915 Energy Processor.

**Flyback Down Converter** - Drop HV DC IN or HV AC1 IN/HV AC2 IN down to 4.06V.

**Energy Processor** - EnerChip EP CBC915 finds the Maximum Peak Power Tracking point of the EH transducer input,

**Transducer Input Voltage Select and Sense Switches** - Monitors all input voltages and connects to the Energy Processor.

**EnerChip CBC51100 Solid State Battery Module** - Two EnerChip 50uAh solid state batteries (CBC3150 and CBC050) for energy storage.

**Low Voltage Cut-off** - Should the voltage on the EnerChips fall below 3.0VDC, this circuit disconnects the batteries so they do not discharge further.

**Energy Management Switching Matrix** - Controls the routing of Vout to the system load. User selectable switches indicate the EH transducer input to voltage output.

**Serial I/O** - These 2 communications lines connect the Energy Processor to another microcontroller such as the TI MSP430 MCU on the eZ430-RF2500 demo kit wireless end device that would plug into connector J9.

# CBC-EVAL-09 EnerChip EP Universal EH Eval Kit

## CBC-EVAL-09 Module Connectors and Switches

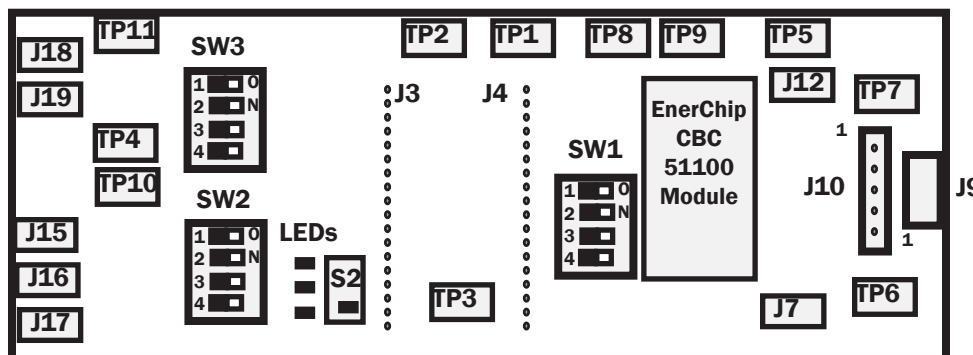

Figure 3: EnerChip EVAL-09 Connections, Test Points and Switches

J18 Low Voltage DC Input	
Pin Number(s)	Designation
1	Positive input
2	GND
Connector Type: 2 pin 100mil	

J19 Low Voltage AC Input	
Pin Number(s)	Designation
1	AC input
2	AC input
Connector Type: 2 pin 100mil	

J15 High Voltage DC Input	
Pin Number(s)	Designation
1	Positive input
2	GND
Connector Type: 2 pin 100mil	

J16 High Voltage AC Input 1	
Pin Number(s)	Designation
1	AC input 1
2	AC input 1
Connector Type: 2 pin 100mil	

J17 High Voltage AC Input 2	
Pin Number(s)	Designation
1	AC input 2
2	AC input 2
Connector Type: 2 pin 100mil	

Test Points for User	
TP Number	Designation
1	4.06V
2	EPVCC
3, 4, 5	GND
6	VCAP
7	V <sub>OUT</sub>
8	VBAT
9	VEC
10	HV DC Vin
11	DC Vin
Connector Type: Clip Lead	

J3 EnerChip EP Pins	
Pin Number(s)	Description
1-19	See CBC915 Datasheet
Connector Type: Circular pad	

J4 EnerChip EP Pins	
Pin Number(s)	Description
20-38	See CBC915 Datasheet
Connector Type: Circular pad	

J9 Connector for User	
Pin Number(s)	Designation
1	RXD
2	GND
3	Not Connected
4	Not Connected
5	V <sub>OUT</sub>
6	TXD
Connector Type: Rt. Angle SIP	

J10 Connector for User	
Pin Number(s)	Designation
1	TXD
2	RXD
3	V <sub>BAT</sub>
4	GND
5	V <sub>OUT</sub>
Connector Type: Vertical SIP	

J7 Connector - External Battery	
Pin Number(s)	Description
1,2	Bypass Diode
Connector Type: Circular pad	

J12 Connector - External Battery	
Pin Number(s)	Description
1	Vextbat input
2	GND
Connector Type: Circular pad	

# CBC-EVAL-09 EnerChip EP Universal EH Eval Kit

---

## EVAL-09 Module Connector and Test Point Explanations

The purpose and use of the connectors identified in Figure 3 and in the previous tables are:

**J1, J2, J8, J11, J13, J14 Connectors** - not user accessible.

**J3 Connector** - EnerChip EP pins 1-19 probe points and access vias.

**J4 Connector** - EnerChip EP pins 20-38 probe points and access vias.

**J5, J6 Connectors** - EVAL-09 debug interface connectors for development system access. Contact Cymbet Applications Engineering for additional details if required.

**J7 Connector** - Bypass diode circular pad trace to select an optional external rechargeable lithium battery with 4.1V charging voltage.

**J9 Connector** - Six pin right angle connector for serial port, Vout and Ground. Normally used for connection to TI eZ430-RF2500 wireless end device or another target system.

**J10 Connector** - Five pin vertical connector for user access to serial port, Vout and Ground.

**J12 Connector** - Access vias for an optional external rechargeable lithium battery with 4.1V charging voltage.

**J15 Connector** - High Voltage DC Input from EH Transducer such as a thermoelectric generator (TEG).

**J16 Connector** - High Voltage AC Input 1 normally used by a piezoelectric EH transducer.

**J17 Connector** - High Voltage AC Input 2 normally used by a piezoelectric EH transducer .

**J18 Connector** - Low voltage DC Input normally used by a photovoltaic cell.

**J19 Connector** - Low voltage AC Input normally used by a thermoelectric generator or electromagnetic generator.

**Cable Assembly** - A 5-conductor cable with a header connector at each end is provided with CBC-EVAL-09 to facilitate connection between the J5 connector and a 5-pin header on the user's board.

**TP1** - the output of the boost converter or FLYBACK converter capacitor. Typical value is 4.06V.

**TP2** - EPVCC - Voltage used to power the CBC915 device should be 3.6V

**TP3, TP3, TP5** - Ground

**TP6** - VCAP - voltage of the output capacitor should be 3.6V

**TP7** - VOUT - output voltage to the target system should be 3.6V

**TP8** - VBAT - output of battery cut-off circuit should be 4.06V

**TP9** - VEC - EnerChip output voltage feeding battery cutoff circuit should be in the range of 4.06VDC to 3.0VDC. Caution: do not leave voltmeter or scope probes attached to this TP. Will discharge EnerChip.

**TP10** - HV V In - DC voltage from the HV DC In or HV AC1 IN or HV AC2 IN ports

**TP11** - V In - DC voltage from the DC In or AC1 IN ports

# CBC-EVAL-09 EnerChip EP Universal EH Eval Kit

## EVAL-09 Transducer Input Switch Settings

There are 3 DIP slider switches on the EVAL-09 for use in selecting the Energy Harvesting Transducer input to the rest of the on-board circuitry. The location of the switches are shown on the EVAL-09 layout diagram shown in Figure 3. There can only be one EH transducer attached to the EVAL-09 at anytime. Combining transducer inputs is not supported.

### Photovoltaic (Solar) Cell Transducer Input Selection on J18

SW3			SW2			SW1		
Slide #	OFF	ON	Slide #	OFF	ON	Slide #	OFF	ON
1		X	1	X		1	X	
2		X	2	X		2	X	
3		X	3	X		3	X	
4		X	4	X		4	X	

### Thermoelectric Generator Transducer Input Selection on J18

SW3			SW2			SW1		
Slide #	OFF	ON	Slide #	OFF	ON	Slide #	OFF	ON
1		X	1	X		1	X	
2		X	2	X		2	X	
3		X	3	X		3		X
4	X		4	X		4	X	

### Electromagnetic/RF Generator Transducer Input Selection on J19

SW3			SW2			SW1		
Slide #	OFF	ON	Slide #	OFF	ON	Slide #	OFF	ON
1		X	1	X		1	X	
2		X	2	X		2	X	
3		X	3	X		3		X
4		X	4	X		4		X

### Piezoelectric Generator Transducer Input Selection on J16 and/or J17

SW3			SW2			SW1		
Slide #	OFF	ON	Slide #	OFF	ON	Slide #	OFF	ON
1	X		1		X	1	X	
2	X		2		X	2	X	
3	X		3		X	3	X	
4	X		4		X	4		X

# CBC-EVAL-09 EnerChip EP Universal EH Eval Kit

---

## EVAL-09 Mode Inquiry Switch and LED Mode Indicators

A push button switch S2 as shown in Figure 3 is used to display the EVAL-09 energy conversion state and charging status. There are 3 LEDs that indicate the 3 modes.

**MPPT LED** – Maximum Peak Power Tracking - Indicates the Energy Processor is adjusting the input impedance to match the transducer impedance. Any time the Energy Processor is performing the MPPT function, the LED will flash momentarily (1 millisecond). The LED will be lit momentarily every time the Energy Processor enters this state or when the push button is pressed. To force MPPT state, hold S2 while connecting the EH transducer. When MPPT LED flashes, release pushbutton. Target system MCU or SW1 changes can also force MPPT.

**Output Holding Cap Charge LED** – This indicates the capacitor used to hold output charge for the target load is being charged. The LED will be lit momentarily every time the Energy Processor enters this state or when the push button is pressed.

**EnerChip Charge LED** - This indicates the EnerChip devices are being charged. The LED will be lit momentarily every time the Energy Processor enters this state or when the push button is pressed.

Charge Sequence Complete - Independent of the push button, once the Energy Processor has completed the sequence of MPPT, Cap Charge and EnerChip Charge, all three LEDs will be flashed for 1 millisecond.

Normal Operating Status - When the Energy Processor is in the Normal Operation State, if the user presses the push button S2 all three LEDs will be flashed for 1msec,

EVAL-09 Output Power Disconnect – In order to remove the output voltage from the target load, the S2 push button is pressed and held for 10 seconds. Initially all three LEDs will flash and after 10 seconds Cap Charge and EC Charge LEDs will flash indicating the output voltage has been disconnected.

EVAL-09 Output Power Reconnect - In order apply output voltage to the target load, the S2 push button is pressed and held for 10 seconds. Initially Cap Charge and EC Charge LEDs will flash and after 10 seconds all three LEDs will flash indicating the output voltage has been reconnected.

Note that during the time the S2 push button is depressed no power is passed from the EVAL-09 to the connected target system.

## Suggested Energy Harvesting Transducers

**Thermoelectric Generators (TEGs)** - There are several vendors of Thermoelectric generators. MicroPelt model MPG-D651 or MPG-D671 have been verified with the CBC-EVAL-09. MicroPelt evaluation system is TE-Power PLUS described on [www.micropelt.com](http://www.micropelt.com) and available at Mouser. Nextreme also supplies a small TEG model eTEG HV56 Power Generator. Contact Nextreme directly at [www.nextreme.com](http://www.nextreme.com).

**Piezo Electric Generator** - There are several vendors of Piezoelectric generators. Mide piezo units V20W, V25W, V21B, V21BL, V22B and V22BL have been verified with the CBC-EVAL-09. Mide's website is [www.mide.com](http://www.mide.com). Another vendor is Advanced Cerametrics with model numbers PFCB-W14, PFCB-W24, and PFCB-W54 will work with the EVAL-09. ACI's website is [www.advancedcerametrics.com](http://www.advancedcerametrics.com).

**Alternate Energy Harvesting Generators** - New solutions for harvesting ambient energy are emerging from companies and universities worldwide. Please contact Cymbet Applications Engineering to discuss any ideas or solutions you are exploring.

# CBC-EVAL-09 EnerChip EP Universal EH Eval Kit

## Operating Characteristics

Parameter	Condition	Min	Typical	Max	Units	
Input Luminous Intensity (DC In; using PV panel provided)	Minimum operating Lux	200 <sup>(1)</sup>	-	-	Lux	
	Full charge rate	700 <sup>(1)</sup>	-	-	Lux	
Average Continuous Output Power (measured at VOUT pin; using PV panel provided)	1000 Lux (FL), battery not charging	-	350	-	μW	
	200 Lux (FL), battery not charging	-	80	-	μW	
DC IN Operating Voltage at Transducer Peak Power Point	source impedance 100Ω to 200Ω	0.2	-	2.5	V	
	source impedance >200Ω	0.5	-	4.0	V	
HV DC IN Operating Voltage at Transducer Peak Power Point	source impedance 10kΩ to 100kΩ	5.0	-	20	V	
DC IN Open Circuit Turn-on Voltage	25 °C	0.4	-	-	V	
HV DC IN Open Circuit Turn-on Voltage	25 °C	5.0	-	-	V	
AC IN Operating Voltage at Transducer Peak Power Point	source impedance 100Ω to 10kΩ	1.2	-	12	Vpp	
HV AC IN (1 and 2) Operating Voltage at Transducer Peak Power Point	source impedance 10kΩ to 100kΩ	14.7	-	57	Vpp	
Quiescent Current	Boost converter on	-	20	-	μA	
	Boost converter off; EnerChips connected	-	800	-	nA	
	CBC915 off; EnerChips connected	-	115	-	nA	
VOUT; 2 μA Load	Battery charged	3.5	3.55	3.6	V	
VCHG Charging Voltage	25 °C	-	4.06	-	V	
Battery Cutoff Voltage	4.7kΩ load	3.0	3.3	3.6	V	
Pulse Discharge Current	20 msec	-	30	-	mA	
Self-Discharge (non-recoverable average)	25 °C	-	2.5	-	% per year	
Operating Temperature	-	0	25	70	°C	
Recharge Cycles (to 80% of rated capacity; 4.1 V charge voltage)	25 °C	10% depth-of-discharge	5000	-	-	-
		50% depth-of discharge	1000	-	-	-
	40 °C	10% depth-of-discharge	2500	-	-	-
		50% depth-of-discharge	500	-	-	-
Recharge Time (to 80% of rated 100μAh capacity) <sup>(2)</sup>	From 50% state-of-charge	-	10	-	minutes	
	From deep discharge	-	50	-	minutes	
Capacity	100μA discharge; 25 °C	100	-	-	μAh	

(1) Fluorescent (FL) light.

(2) Assuming charge rate is not limited by input power available from transducer.

**Specifications subject to change without notice.**

# CBC-EVAL-09 EnerChip EP Universal EH Eval Kit

## EVAL-09 Circuit Schematics

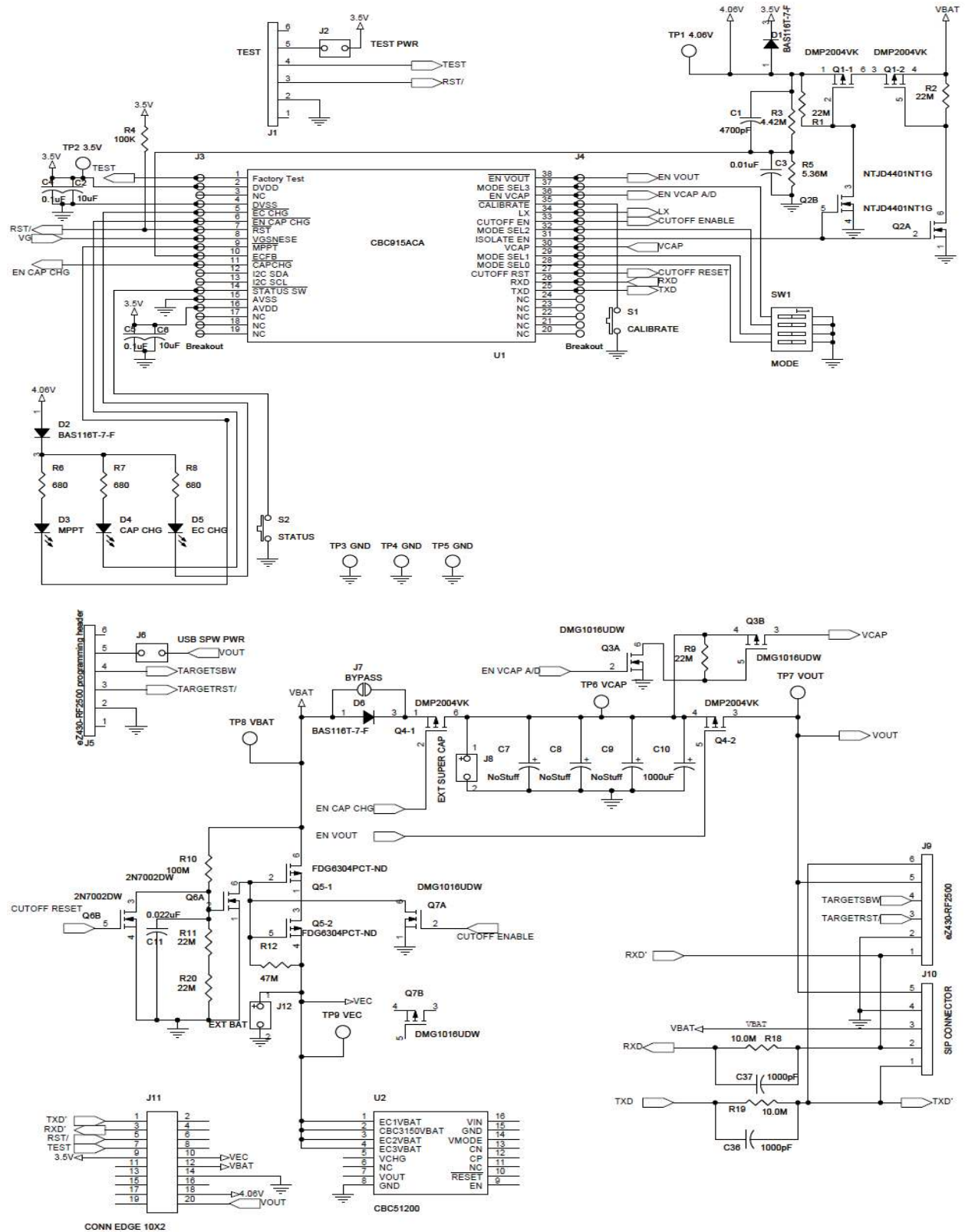



# CBC-EVAL-09 EnerChip EP Universal EH Eval Kit

## EVAL-09 Circuit Schematics

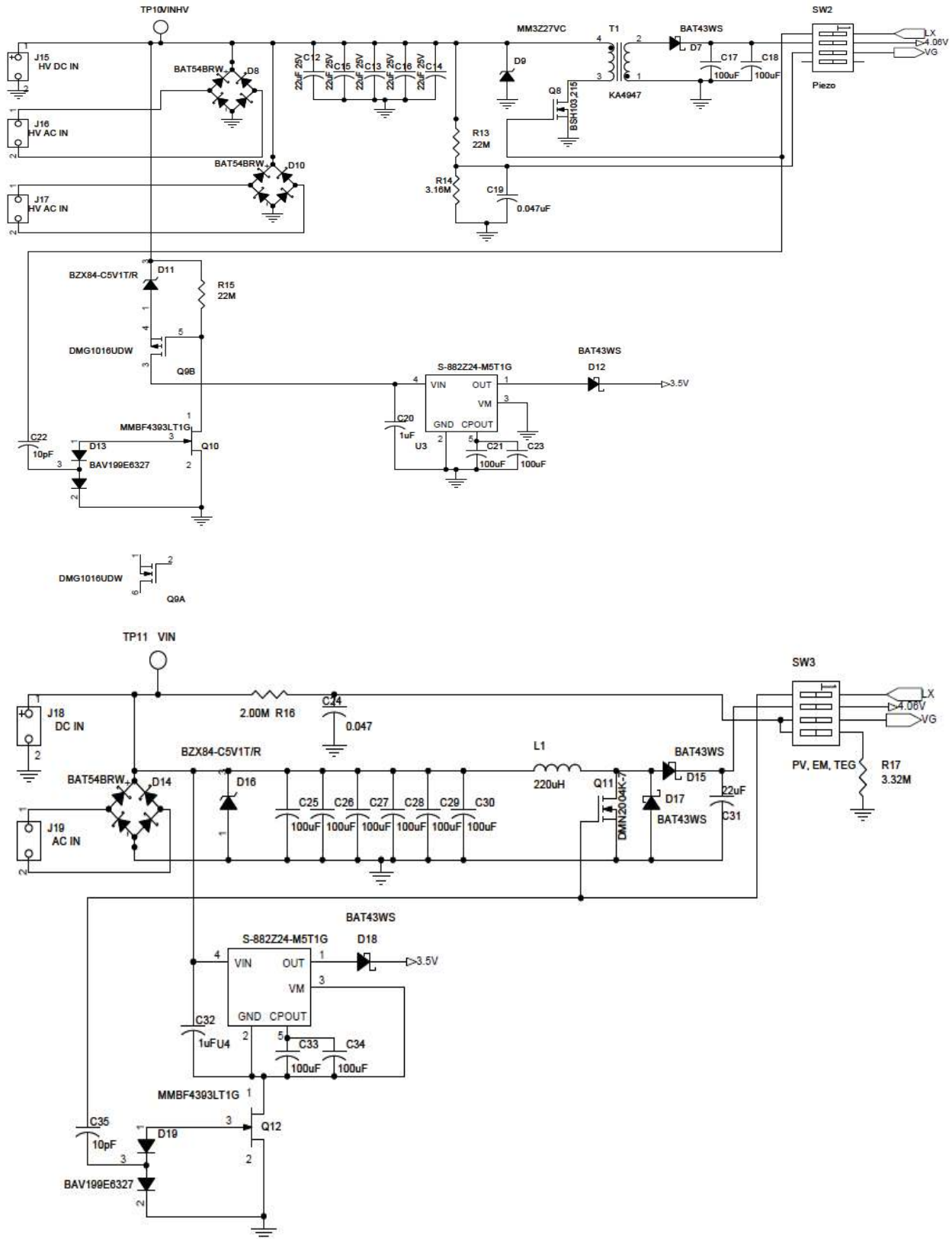

# CBC-EVAL-09 EnerChip EP Universal EH Eval Kit

## CBC-EVAL-09 Bill of Materials

The components on the EVAL-09 main board are as follows:

Quantity	Reference Designator	Manufacturer	Manufacturer Part #	Description
3	R6,R7,R8	Yageo	RC0402JR-07680RL	RES 680 OHM 1/16W 5% 0402 SMD
1	R4	Vishay/Dale	CRCW0402100KFKED	RES 100K OHM 1/16W 1% 0402 SMD
1	R16	Vishay/Dale	CRCW04022M00FKED	RES 2.00M OHM 1/16W 1% 0402 SMD
1	R3	Vishay/Dale	CRCW04024M42FKED	RES 4.42M OHM 1/16W 1% 0402 SMD
1	R14	Vishay/Dale	CRCW04023M16FKED	RES 3.16M OHM 1/16W 1% 0402 SMD
1	R17	Vishay/Dale	CRCW04023M32FKED	RES 3.32M OHM 1/16W 1% 0402 SMD
1	R5	Vishay/Dale	CRCW04025M36FKED	RES 5.36M OHM 1/16W 1% 0402 SMD
1	R11	Panasonic - ECG	ERJ-8GEYK226V	RESISTOR 22M OHM 1/4W 10% 1206
1	R20	Stackpole Electronics Inc	RMCF0805JT22M0	RES 22M OHM 1/8W 5% 0805 SMD
1	R12	Vishay/Dale	CRCW080547M0JPTA	RES 47M OHM 1/8W 5% 1206 SMD
1	R10	Vishay/Dale	CRCW1206100M0JPTAHR	RES 100M OHM 1/4W 5% 1206 SMD
2	R18,R19	Stackpole	RMCF1H610M 1%R	RES 10M OHM 1/10W 1% 0603 SMD
5	R1,R2,R9,R13,R15	Stackpole	RMCF0603JT22M0CT-ND	RES 22M OHM 1/10W 5% 0603 SMD
2	C22,C35	Murata Electronics N.A.	GRM1555C1H100JZ01D	CAP CER 10PF 50V 5% COG 0402
2	C36,C37	Murata Electronics N.A.	GRM155R71H102KA01D	CAP CER 1000PF 50V 10% X7R 0402
1	C1	Murata Electronics N.A.	GRM155R71E472KA01D	CAP CER 4700PF 25V 10% X7R 0402
1	C3	Murata Electronics N.A.	GCM155R71H103KA55D	CAP CER .01UF 50V X7R 0402
2	C19,C24	Murata Electronics N.A.	GCM155R71E473KA55D	CAP CER .047UF 25V X7R 0402
2	C4,C5	Murata Electronics N.A.	GRM155R61A104KA01D	CAP .1UF 10V CERAMIC X5R 0402
1	C11	Taiyo Yuden	LMK105B7223KV-F	CAP .022UF 10V CERAMIC X5R 0402
2	C20,C32	Panasonic - ECG	ECJ-0EB1A105M	CAP CERAMIC 10UF 10V X5R 0402
2	C2,C6	TDK Corporation	C1608X5R0J106M	CAP CER 10UF 6.3V X5R 0603
5	C12,C13,C14,C15,C16	TDK Corporation	C3225Y5V1E226Z	CAP CER 22UF 25V Y5V 1210
1	C31	Murata Electronics N.A.	GRM31CR60J226KE19L	CAP 22UF 6.3V CERAMIC X5R 1206
12	C17,C18,C21,C23,C25,C26,C27, C28,C29,C30,C33,C34	Murata Electronics N.A.	GRM31CF50J107ZE01L	CAP CER 100UF 6.3V Y5V 1206
1	C10	Vishay/Sprague	592D108X96R3R2T20H	CAP TANT 1000UF 6.3V 10% SMD
1	L1	Coil Craft	DS1608C-224MLB	INDUCTOR 220uH SHIELDED SMD
1	T1	Coil Craft	KA4947-AL	FLYBACK TRANSFORMER
3	D1,D2,D6	Diodes Inc	BAS116T-7-F	DIODE SWITCH 85V 150MW SOT523
5	D7,D12,D15,D17,D18	Micro Commercial Co.	BAT43WS-TP	DIODE SCHOTTKY 30V 200MA SOD323
3	D8,D10,D14	Micro Commercial Co	BAT54BRW-TP	DIODE ARRAY SCHOTTKY 200MW 30V SOT363
2	D11,D16	NXP Semiconductors	BZX84-C5V1 T/R	DIODE ZENER 250mW 5.1V 5% SOT23
3	D3,D4,D5	OSRAM Opto	LO L29K-H2L1-24-0-2-R18-Z	LED SMARTLED 606NM OPN 0603 SMD
1	D9	Fairchild	MM3Z27VC	DIODE ZENER 27V 200mW SOD-323F
2	D13,D19	Infineon Technologies	BAV199E6327	DIODE ARRAY 85V SOT-23
1	Q11	Diodes Inc	DMN2004K-7	MOSFET N-CH 540MA 20V SOT-23
3	Q3,Q7,Q9	Diodes Inc	DMG1016UDW	MOSFET N-P 20,8V 630MA SOT-363
2	Q1,Q4	Diodes Inc	DMP2004VK	MOSFET 2P-CH 8V 775MA SOT-563
1	Q5	Fairchild	FDG6304P	IC FET DGTL P-CHAN DUAL SC70-6
1	Q6	mcc	2N7002Dw	MOSFET N-CHAN DUAL 25V SC70-6
1	Q2	Diodes Inc	BSS138DW-7-F	MOSFET 2N-CH 20V 630MA SOT-363
1	Q8	NXP Semiconductors	BSH103,215	MOSFET N-CH 30V 0.85A SOT23
		NXP Semiconductors	PMBF4393,215	
2	Q10,Q12	ON Semiconductor	MMBF4393LT1G	TRANS JFET SW N-CHAN 30V SOT23
2	U3,U4	Seiko Instruments	S-882224-M5T1G	IC CHARGE PUMP CONV 2.4V SOT23-5
1	U1	Cymbet	CBC915-ACA	ENERCHIP ENERGY PROCESSOR
1	U2	Cymbet	CBC51100	16-PIN DIP 100uAh ENERCHIP CC MODULE
0.3	J15,J16,J17,J18,J19,J10	Samtec	TSW-150-07-G-S	CONN HEADER 50POS .100" SGL GOLD
0.12	J9	Mill-Max	850-10-050-20-001000	CONN HEADER RT ANG 50POS .050
0.25	U2	Mill-Max	310-43-164-41-001000	STRIP SOCKET 64 PIN SOLDER TAIL rohs
1	PCB1	Cymbet	310055 REV. C	PRINTED CIRCUIT BOARD
4	FEET	3M	SJ-5303	BUMPON HEMISPHERE .44X.20 CLEAR
1	LABEL			SERIAL NUMBER LABEL - BAR CODE
	TP1,TP2,TP3,TP4,TP5,TP6, TP7,TP8,TP9,TP10,TP11	Keystone Electronics	5016	PC TEST POINT COMPACT SMT
3	Sw1,Sw2,Sw3	Copal Electronics Inc	CHS-04TA	SWITCH DIP 4-POS SLIDE SMD
1	S2	E-Switch	TL1015AF160QG	SWITCH TACT TOP ACT 160GF SMD

# CBC-EVAL-09 EnerChip EP Universal EH Eval Kit

---

## Pulse Discharge Current for a Wireless End Device

Pulse discharge currents place special demands on batteries. Repeated delivery of pulse currents exceeding the recommended load current of a given chemistry will diminish the useful life of the cell. The effects can be severe, depending on the amplitude of the current and the particular cell chemistry and construction. Pulse currents of tens of milliAmperes are common in wireless sensor systems during transmit and receive modes. Moreover, the internal impedance of the cell often results in an internal voltage drop that precludes the cell from delivering the pulse current at the voltage necessary to operate the external circuit.

This important issue is covered in Cymbet Applications note AN-1025 available on [cymbet.com](http://cymbet.com).

## Battery Protection

The EVAL-09 board contains a low battery cutoff circuit that prevents the EnerChips on the CBC51100 module from being completely discharged - a condition that would permanently damage the battery. The cutoff circuit places a parasitic 400nA load on the battery - a load that would discharge the two EnerChips in approximately 125 hours, or just over 5 days. If the EnerChips are allowed to reach the cutoff voltage at such low discharge currents, their specified cycle life will be reached after a few hundred of such deep discharge cycles. To avoid this condition and extend the service life of the EnerChip, it is advisable to program the MCU to count transmission cycles or elapsed time to determine when the EnerChips' state-of-charge is approximately 50%, at which time the MCU would force itself or another system circuit element to briefly draw high power from the CBC-EVAL-09, forcing the CBC-EVAL-09 circuit into a cutoff mode and thereby disconnecting the EnerChips from the circuit. Drawing a brief burst of a few milliamperes from the CBC-EVAL-09 will force the cutoff condition to occur within a few seconds. This will ensure that the charge/discharge cycle life of the EnerChips will be greater than 5000, as rated. To calculate the number of hours the EnerChips are capable of supplying energy to the load, add the cutoff current to the average load current drawn by the system and divide the sum into the combined 100 $\mu$ Ah capacity of the two EnerChips. The quotient is the number of hours until the EnerChip is totally depleted. Divide that number in half to reach the 50% depth-of-discharge time.

## Guidelines for Attaching Other Energy Harvesting Transducers

Other energy harvesting transducers (e.g., inductive, piezoelectric, thermoelectric) may be attached to the CBC-EVAL-09. As configured, the CBC-EVAL-09 will operate with many other transducer types. However, performance specifications of these other transducers - namely output impedance - will affect the power conversion efficiency of the CBC-EVAL-09 kit as designed. Please contact Cymbet Applications Engineering at the phone number shown below to discuss your specific application and desired alternate transducer(s).

## System Level Considerations when Using a Low Power Energy Harvester

The EVAL-09 is capable of supplying 10s to 100s of  $\mu$ W of continuous power to the load. Most applications operating with radios and microcontrollers typically need 10s to 100s of mW of power under peak load conditions. The disparity between what is available and what is needed can be made up by limiting the amount of time the load is powered and waiting sufficient time for the energy harvester to replenish the energy storage device before the subsequent operation commences. In typical remote RF sensor applications, the 'on' time will be on the order of 5-20ms, with an 'off' time of several seconds to several hours depending on the application and available energy source. The duty cycle is an important consideration when designing a wireless system. While it is relatively straightforward to calculate a power budget and design a system to work within the constraints of the power and energy available, it is easy to overlook the power required to initialize the system to a known state and to complete the radio link with the host system or peer nodes in a mesh network. The initialization phase can sometimes take two to three times the power needed for steady state operation.

Ideally, the hardware should be in a low power state when the system power-on reset is in its active state. If this is not possible, the microcontroller should place the hardware in a low power state as soon as possible. After this is done, the microcontroller should be put into a sleep state long enough for the energy harvester

## CBC-EVAL-09 EnerChip EP Universal EH Eval Kit

---

to replenish the energy storage device. If the power budget is not exceeded during this phase, the system can continue with its initialization. Next, the main initialization of the system, radio links, analog circuits, and so forth, can begin. Care should be taken to ensure that the time the system is on during this phase does not exceed the power budget. Several sleep cycles might be needed to 'stair step' the system up to its main operational state. The EnerChip EP CBC915-ACA Energy Processor has a serial port to communicate to a microcontroller when energy is available.

### Circuit Recommendations to Save Power

In most system power budgets, the peak power required is not as critical as the length of time the power is required. Careful selection of the message protocol for the RF link can have a significant impact on the overall power budget. In many cases, using higher power analog circuits that can be turned on, settle quickly, and be turned off can decrease the overall energy consumed. Microcontroller clock frequency can also have a significant impact on the power budget. In some applications it might be advantageous to use a higher microcontroller clock frequency to reduce the time the microcontroller and peripheral circuits are active. Avoid using circuits that bias microcontroller digital inputs to mid-level voltages; this can cause significant amounts of parasitic currents to flow. Use  $10M\Omega$  to  $22M\Omega$  pull-up/down resistors where possible. However, be aware that high circuit impedances coupled with parasitic capacitance can make for a slow rise/fall time that can place the voltage on the microcontroller inputs at mid-levels, resulting in parasitic current flow. One solution to the problem is to enable the internal pull-up/down resistor of the microcontroller input to force the input to a known state, then disable the resistor when it's time to check the state of the line. If using the microcontroller's internal pull-up/down resistors on the inputs to bias push-button switches in a polled system, leave the pull-up/down resistor disabled and enable the resistor only while checking the state of the input port. Alternatively, in an interrupt-driven system, disable the pull-up/down resistor within the first few instructions in the interrupt service routine. Enable the pull-up/down resistor only after checking that the switch has been opened.

Microcontroller pull-up/down resistors are typically less than  $100k\Omega$  and will be a huge load on the system if left on continuously while a button is being pressed or if held for any significant length of time. For even greater reduction in power, use external pull-up/down resistors in the  $10M\Omega$  to  $22M\Omega$  range. Bias the external resistor not with the power rail but with a microcontroller port. The same algorithm used for internal pull-up/down resistors can then be used to save power. The CHARGE line on the CBC5301 has a  $10M\Omega$  pull-up resistor with a very slow rise time. Use an internal microcontroller pull-down resistor to force the CHARGE line low all of the time and then disable the pull-down resistor to check the state of the line. This will keep the CHARGE line from biasing the input at mid level for long periods of time which could cause large parasitic currents to flow.

# CBC-EVAL-09 EnerChip EP Universal EH Eval Kit

---

## Frequently Asked Questions

- Q: Do I have enough input power from the EH transducer to charge the EnerChip batteries?  
A: The CBC915 energy processor is initially started with charge pump U3 in piezo mode or U4 when in low voltage mode and accumulates enough charge into the CPOUT capacitors to then dump this charge in to the CBC915 VCC line. This action can be monitored on TP2 (EPVCC) test point. The voltage will typically be around 2.5 volts and last for a few seconds if there is sufficient energy to operate the charge pump, but not enough energy to run the CBC915 energy processor. If there is sufficient energy to sustain the CBC915 energy processor, the TP2 voltage will start up at 2.5V and then jump up to approximately 3.5V. At this point the MPPT LED will flash indicating the CBC915 is entering the Maximum Peak Power Tracking state. Checking TP1 4.06V for a voltage near 4.06 Volts while the energy processor is finding the MPP point will also give an indication if sufficient power is available.
- Q: What if I short-circuit the output?  
A: The disconnect circuit will disconnect the EnerChip devices from the output after the capacitor is discharged below 3.0V. This prevents the EnerChips from being discharged too deeply. The EnerChip device will automatically reconnect after the capacitor is recharged.
- Q: What happens if I want to run a larger pulse current application?  
A: See application note AN-1025. The EVAL-09 output capacitor bank can be sized to drive almost any load as long as the duration is not too long. AN-1025 describes how to calculate the capacitor size.
- Q: What happens if the EnerChip is short-circuited? Will it explode or leak harmful chemicals?  
A: No. There are no harmful chemicals to leak and the energy storage cells will not explode.
- Q: How long will the CBC-EVAL-09 module operate with no ambient light?  
A: This depends on many factors, including load power consumption, EnerChip state-of-charge, operating temperature, etc. The EnerChips on the CBC51100 module provide 100 $\mu$ Ah of discharge capacity when fully charged.
- Q: How long will the CBC-EVAL-09 module last if I use it every day and input power is available most of the time?  
A: The CBC-EVAL-09 module should last at least 10 years.
- Q: How long will the two EnerChips on the CBC51100 module hold a charge, assuming no input power?  
A: The self-discharge of the EnerChip is a function of several parameters, including temperature. Self-discharge specifications can be found in the product data sheets at <http://www.cymbet.com/content/products-resource-docs.asp>.
- Q: What happens if the EnerChip is left in a discharged state for a long period of time?  
A: Leaving the EnerChip in a discharged state is not detrimental to its performance.
- Q: I see no voltage on VOUT.  
A: Make sure there is sufficient input power to operate the CBC3150 charge pump and that the output is not short-circuited.
- Q: Will the CBC-EVAL-09 disconnect the EnerChips before they become too deeply depleted?  
A: Yes, the CBC-EVAL-09 has a cutoff circuit that will prevent the EnerChips from being damaged due to over-discharge. However, repeatedly operating the system in a mode that allows the cutoff circuit to be invoked at deep discharge will cause premature capacity fade and shorter product life. If it is anticipated that the low voltage cutoff point will be reached, it is better to put the system into a high power mode to force cutoff at a higher state-of-charge, thereby prolonging the life of the EnerChips.

## CBC-EVAL-09 EnerChip EP Universal EH Eval Kit

- Q: How can the EVAL-09 startup time be reduced and the time it takes the CBC915 to find the maximum peak power point?
- A: The EVAL-09 utilizes a Seiko S-882Z24-M5T1G charge pump to accumulate energy at startup and then dumps this energy into the CBC915 energy processor. Once the CBC915 starts up, it automatically disables the Seiko charge pump and operates a more efficient inductive boost converter. Another approach to start the CBC915 when energy is available, is to pre-charge the on-board EnerChips and then use the base of an NPN bipolar transistor to sense when input voltage is available and tie the collector of the transistor into the cutoff circuit as a wired OR. When energy is available from the energy harvesting transducer, the transistor will turn on and cause energy stored in the EnerChips to initially power the CBC915 energy processor. This approach has the advantage of being “instant on”, but requires a board-level manufacturing process that can pre-charge the EnerChips and requires a transducer to have a minimum of one forward PN junction voltage before the transistor will turn on. The charge pump method operates at a lower voltage but in the case of piezo electric transducers has a large impedance mismatch between the piezo element and the input into the charge pump so it can take a long time (several minutes) before enough charge is accumulated to dump into the CBC915 energy processor.

The length of time the CBC915 takes to find the maximum peak power point is largely influenced by the stability of the input signal generated by the energy harvesting transducer. Mechanical transducers tend to have the most electrical input noise and consequently take the most time for the CBC915 to find the maximum peak power point. Take steps to reduce noise such as filter capacitors in the several thousand microfarad range. After the first time the CBC915 finds the maximum peak power point, the coefficients used to find the point are stored in memory. The next time the CBC915 is powered up it will use the coefficients and not try to find the maximum peak power point again unless the system falls out of voltage regulation or is commanded to find the maximum peak power point by the application circuit microcontroller.

### Ordering Information

EnerChip Part Number	Description	Notes
CBC-EVAL-09	EnerChip Universal Energy Harvesting Demo Kit	Contains Solar Cell and CBC51100 Module
CBC915-ACA	EnerChip EP Energy Processor	Packaged in Tape and Reel or Tubes
CBC050-M8C	EnerChip 50uAh Solid State Battery	Packaged in Tape and Reel or Tubes
CBC3150-D9C	EnerChip CC 50uAh Solid State Battery with Charge Control	Packaged in Tape and Reel or Tubes

#### Disclaimer of Warranties; As Is

The information provided in this data sheet is provided “As Is” and Cymbet Corporation disclaims all representations or warranties of any kind, express or implied, relating to this data sheet and the Cymbet battery product described herein, including without limitation, the implied warranties of merchantability, fitness for a particular purpose, non-infringement, title, or any warranties arising out of course of dealing, course of performance, or usage of trade. Cymbet battery products are not approved for use in life critical applications. Users shall confirm suitability of the Cymbet battery product in any products or applications in which the Cymbet battery product is adopted for use and are solely responsible for all legal, regulatory, and safety-related requirements concerning their products and applications and any use of the Cymbet battery product described herein in any such product or applications.

**Cymbet, the Cymbet Logo and EnerChip are trademarks of Cymbet Corporation. All Rights Reserved  
EnerChip products and technology are covered by one or more patents or patents pending.**