

THIS DRAWING IS THE PROPERTY OF DAVIES MOLDING COMPANY, IS SUBMITTED SOLELY AS A DESIGN OR ENGINEERING PROJECT. WE ACCEPT NO RESPONSIBILITY WHATSOEVER FOR THE PRACTICAL APPLICATION OF THE PIECES MADE TO THIS DESIGN.

M NO.	3084
CAVITY	3084
CORE	3084
TOP PIN	LONG (1.501)
SLEEVE	3084
PIN	3084
INSERT	10035

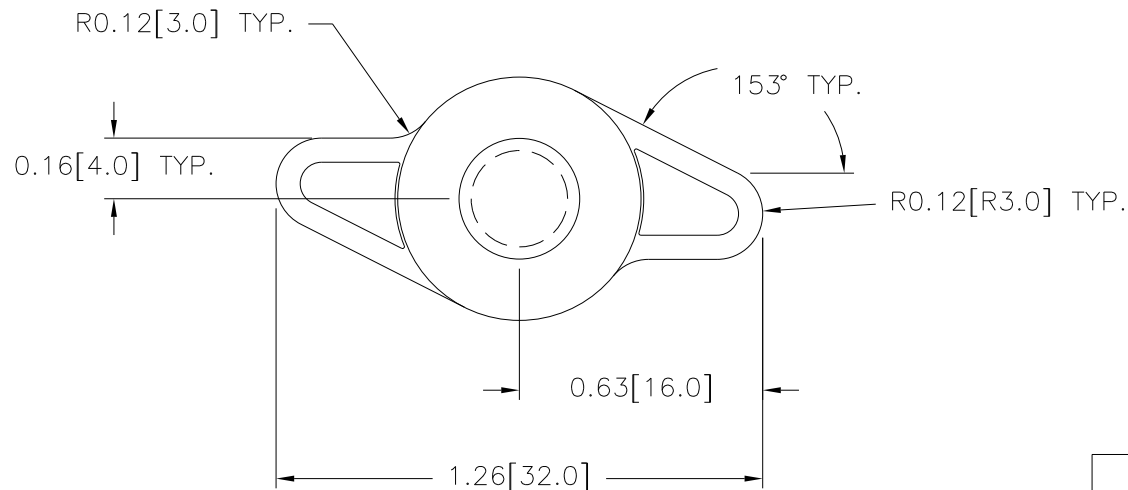
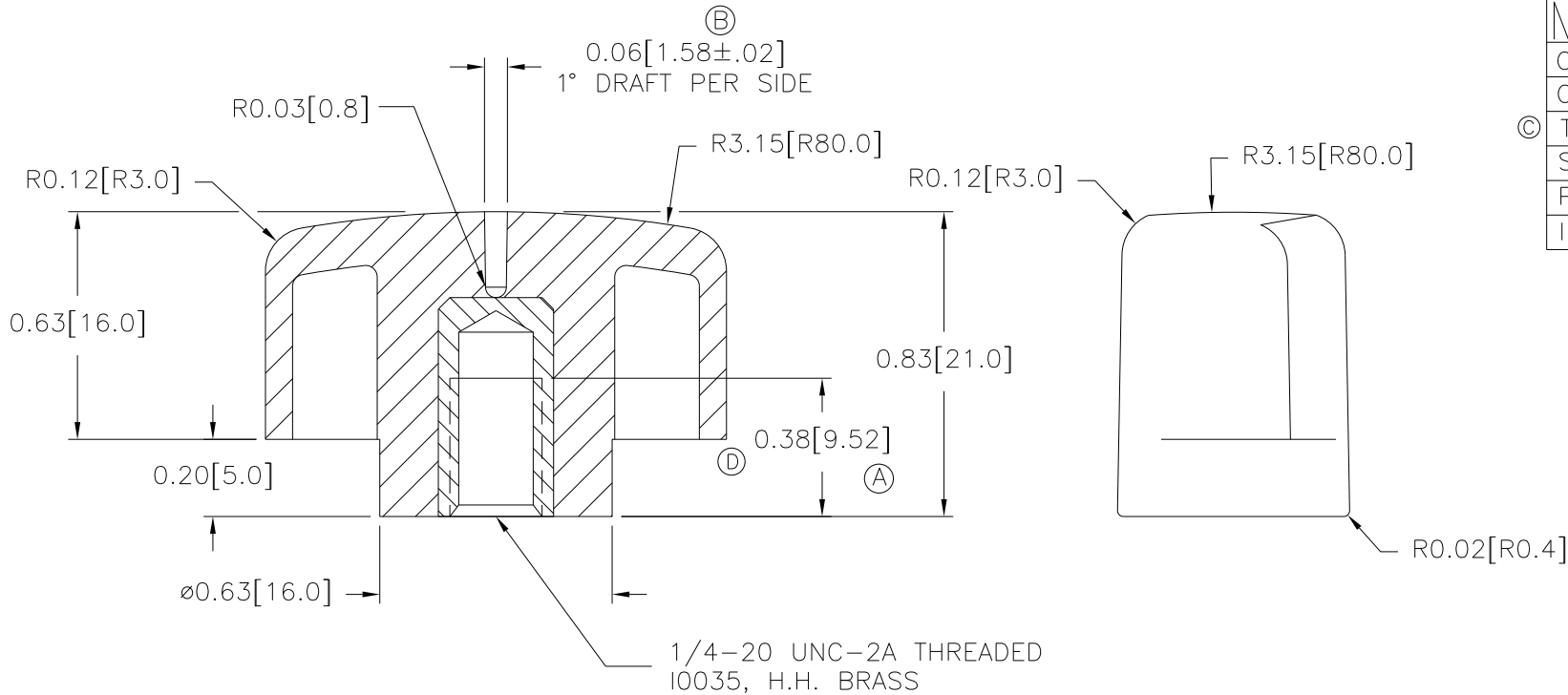

MATERIAL: HIPS (CLB) (E)  
COLOR: BLACK

NOTE(S) :

- (1) DRAFT PER SIDE 1° MAX. UNLESS OTHERWISE SPECIFIED.
- (2) DIMENSIONS SHOWN ARE MINUS DRAFT.
- (3) ALL EXTERNAL SURFACES TO BE RAWAL TEXTURE (MT-11010)
- (4) MOLDED PARTS MUST PASS IMPACT TEST PER S-B POWER TOOL COMPANY STD. C-5.6 IS
- (5) GATE AND EJECTOR PIN LOCATIONS MUST BE APPROVED BY S-B POWER TOOL CO. ENGINEERING DEPT. AND SHOWN ON DWG.
- (6) ALL RADII TO BLEND SMOOTH WITH ADJOINING SURFACES.

E	ADDED MAT. CODE	JAM	6/25/12
D	REMOVED RADIUS	JAM	10/15/09
C	WAS 1.515	TS	5/14/2001
B	WAS 1.60	TL	7/21/99
A	WAS 6.35	TL	7/21/99
-	WAS SK3084-2	TS	9/9/98

TOLERANCES: UNLESS OTHERWISE SPECIFIED	DO NOT SCALE DRAWING
DECIMALS: X.XXX ± .005 X.XX ± .015	MM: X.XX ± 0.15MM X.X ± 0.4MM
FRACTIONS ± 1/64	ANG. ± 1°

CHANGES