

# F5B, Metallized Polyester Film with Integrated Suppression Diode 18 – 63 VDC

## Overview

The F5B series is a metallized polyester (MKT) film capacitor with an integrated suppression diode, encapsulated in a thermosetting, resin-filled, plastic box with tinned wire leads. Box material is solvent-resistant and flame-retardant, meeting the requirements of UL 94 V-0.

## Applications

For worldwide use as EMI/RFI and advanced transient voltage suppressors for automotive motors and other suppression applications. These include engine blower fans, central locking systems, heating/air-conditioning blowers, electric sun roofs, electric window regulators, fuel/oil pumps, electric windshield wipers, and electrically operated seats. This through-hole EMI/RFI suppression element is mainly used for automotive applications without a printed circuit board (e.g. motor suppression) or mixed through-hole and surface-mount printed circuit boards.

## Benefits

- Low-inductive MKT capacitors in parallel construction with a high-power bidirectional transient voltage suppressor diode in a single case that provides superior suppression results
- Approvals: AEC-Q200 (in progress), ISO7637
- Rated Voltage: 18 – 63 VDC
- Capacitance Range: 0.1 – 2.2  $\mu$ F
- Lead Spacing: 5 mm
- Capacitance Tolerance:  $\pm$ 10%,  $\pm$ 20%
- Climatic Category: 55/125/56 IEC 60068-1
- Tape & Reel packaging in accordance with IEC 60286-2
- RoHS compliance and lead-free terminations
- Operating temperature range: -55°C to +125°C

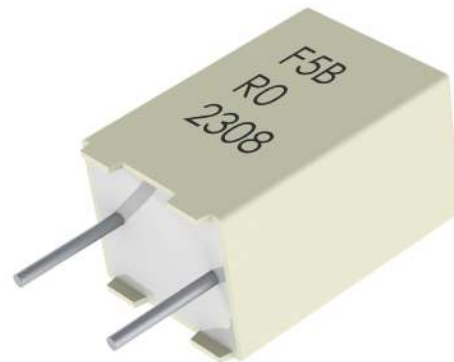

## Part Number System

F5B	H	C	4100	DQ	A	7	K
Series	Rated Voltage (VDC)	Lead Spacing (mm)	Capacitance Code (pF)	Lead and Packaging Code	Diode Breakdown Voltage $V_{BR}$ at 1 mA	Size Code	Capacitance Tolerance
Film Capacitor/ Diode Unit	B = 18 H = 25 J = 30 N = 45 C = 50 D = 63	C = 5 mm	Digits 2 – 4 indicate the first three digits of the capacitance value. The first digit indicates the number of zeros to be added.	See Ordering Options Table	See Diode Breakdown Voltage table	See Dimension Table	K = $\pm$ 10% M = $\pm$ 20%

## Ordering Options Table

Lead Spacing Nominal (mm)	Type of Leads and Packaging	Lead Length (mm)	Lead and Packaging Code
5	<b>Standard Lead and Packaging Options</b>		
	Bulk (Bag) – Short Leads	4 +2/-0	AA
	Ammo Pack	$H_0 = 18.5 \pm 0.5$	DQ
	<b>Other Lead and Packaging Options</b>		
	Bulk (Bag) – Long Leads	17 +1/-2	Z3
	Tape & Reel (Standard Reel)	$H_0 = 18.5 \pm 0.5$	CK

## Dimensions – Millimeters

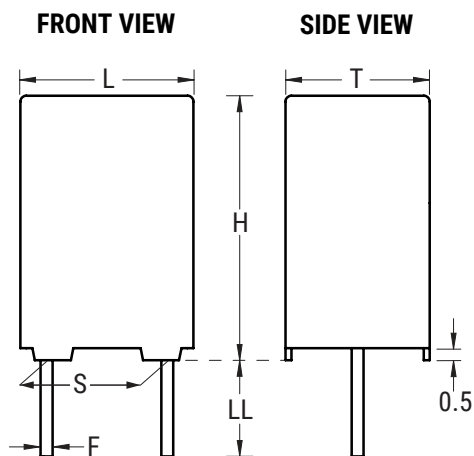

Rated Capacitance $\mu\text{F}$	Size Code	S		T		H		L		F	
		Nominal	Tolerance	Nominal	Tolerance	Nominal	Tolerance	Nominal	Tolerance	Nominal	Tolerance
0.1 – 1.2	7	5	$\pm 0.4$	6.1	Maximum	11.1	Maximum	7.5	Maximum	0.6	$\pm 0.05$
1.5 – 2.2	8	5	$\pm 0.4$	7.3	Maximum	13.1	Maximum	7.5	Maximum	0.6	$\pm 0.05$

**Note: See the Ordering Options Table for lead length (LL) options.**

## Circuit Diagram

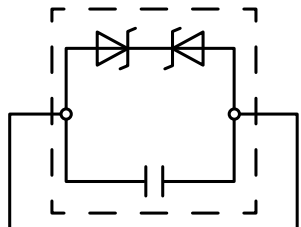

## Diode Breakdown Voltage & Clamping Voltage Table

Part Number Digit 4		Part Number Digit 12		Clamping Voltage (Pulse 10/700 $\mu$ s)	
Letter	$V_R$ (VDC)	Letter	$V_{BR}$ (VDC)	$V_C$ (V)	$I_p$ (A)
B	18	B	22	28	24
B	18	E	27	33	31
H	25	A	30	36	20
H	25	C	33	40	19
J	30	D	36	43	18
J	30	I	39	46	17
J	30	N	44	52	16
N	45	B	53	62	14
C	50	C	68	78	12
D	63	C	78	89	11

## Performance Characteristics

Rated Voltage	18 – 63 VDC (For temperature over 100°C a decreasing factor of 2% per degree has to be applied on the rated voltage $V_R$ )
Capacitance Range	0.1 – 2.2 $\mu$ F
Capacitance Tolerance	$\pm 10\%$ , $\pm 20\%$
Temperature Range	-55°C to +125°C
Climatic Category	55/125/56, IEC 60068-1
Leakage Current	$\leq 50 \mu$ A at $V_R$
Approvals	AEC-Q200 (in progress), ISO 7637-2
Dissipation Factor	0.01 (1 kHz at 25°C $\pm 5^\circ$ C)
Test Voltage Between Terminals	100 VDC
Insulation Resistance	1 M $\Omega$ at 12 V (24 V for $V_R > 24$ V)
Diode	600 W TVS diode, bidirectional
Peak Current Pulse	10/700 $\mu$ s
Peak Current	See Diode Breakdown Voltage & Clamping Voltage Table

## Environmental Compliance

All KEMET pulse capacitors are RoHS compliant.



## Impedance Graph

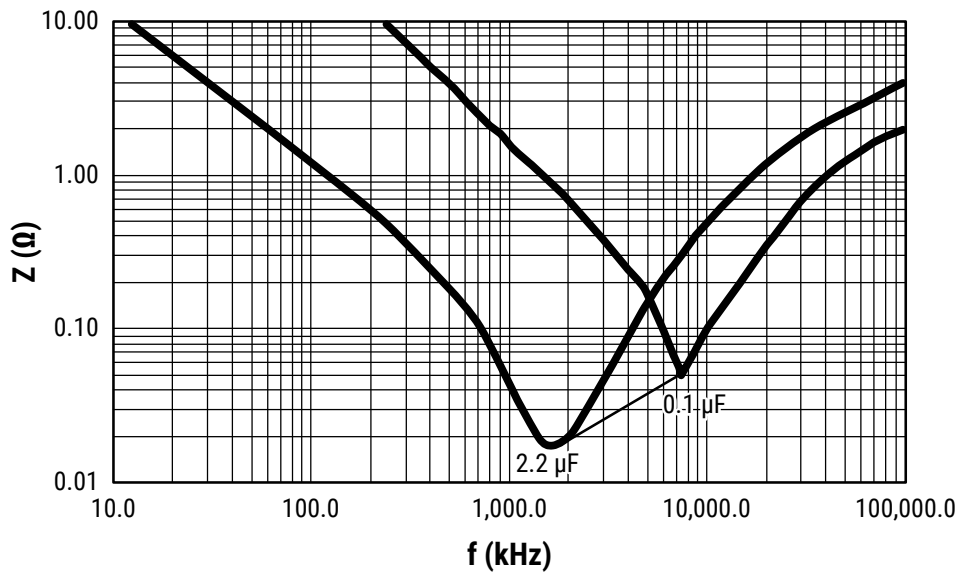

## Environmental Test Data

Test	Conditions	Performance	
Damp Heat Steady State	+40°C ±2°C and 93% ±2% RH, 56 days	Δ C/C	≤ 5%
		V <sub>BR</sub> Change	≤ 10%
		DF Change	≤ 50 x 10 <sup>-4</sup> at 1 kHz
		Leakage Current at V <sub>R</sub>	≤ 100 μA
Endurance	+125°C ±2°C/100°C ±2°C, 0.5 x V <sub>R</sub> /1.0 x V <sub>R</sub> , 1,000 hours	Δ C/C	≤ 10%
		V <sub>BR</sub> Change	≤ 10%
		DF Change	≤ 50 x 10 <sup>-4</sup> at 1 kHz
		Leakage Current at V <sub>R</sub>	≤ 100 μA
Resistance to Soldering Heat	+260°C ±5°C, 10 ±1 second	Δ C/C	≤ 3%
		V <sub>BR</sub> Change	≤ 5%
		DF Change	≤ 30 x 10 <sup>-4</sup> at 1 kHz
		Leakage Current at V <sub>R</sub>	≤ 50 μA
Peak Current Derating	Pulse 10/700 μs, 300 V <sub>p</sub> , 100 cycles with alternating polarity, 120 seconds between each current peak	Δ C/C	≤ 10%
		V <sub>BR</sub> Change	≤ 10%
		DF Change	≤ 30 x 10 <sup>-4</sup> at 1 kHz
		Leakage Current at V <sub>R</sub>	≤ 100 μA
Long-Term Stability (After 2 Years)	-40°C to +80°C, ≤ 70% humidity	Δ C/C	≤ 3%
		V <sub>BR</sub> Change	≤ 5%
		DF Change	≤ 20 x 10 <sup>-4</sup> at 1 kHz
		Leakage Current at V <sub>R</sub>	≤ 50 μA
Reliability Failure Criteria	Reference MIL HDB 217 +40°C ±2°C, 0.5 x V <sub>R</sub> , ≤ 5 FIT	Δ C/C	> 10%
		V <sub>BR</sub> Change	> 10%
		DF Change	≥ 20 x 10 <sup>-4</sup> at 1 kHz
		Leakage Current at V <sub>R</sub>	> 200 μA

**Table 1 – Ratings & Part Number Reference**

Capacitance Value (µF)	VDC	Max Dimensions in mm			Lead Spacing (S)	Diode Breakdown Voltage (VDC)	KEMET Part Number	Legacy Part Number
		T	H	L				
0.10	18	6.1	11.1	7.5	5.0	22	5BBC3100(1)B7(2)	F5BBC3100(1)B7(2)
0.10	18	6.1	11.1	7.5	5.0	27	5BBC3100(1)E7(2)	F5BBC3100(1)E7(2)
0.22	18	6.1	11.1	7.5	5.0	22	5BBC3220(1)B7(2)	F5BBC3220(1)B7(2)
0.22	18	6.1	11.1	7.5	5.0	27	5BBC3220(1)E7(2)	F5BBC3220(1)E7(2)
0.33	18	6.1	11.1	7.5	5.0	22	5BBC3330(1)B7(2)	F5BBC3330(1)B7(2)
0.33	18	6.1	11.1	7.5	5.0	27	5BBC3330(1)E7(2)	F5BBC3330(1)E7(2)
0.47	18	6.1	11.1	7.5	5.0	22	5BBC3470(1)B7(2)	F5BBC3470(1)B7(2)
0.47	18	6.1	11.1	7.5	5.0	27	5BBC3470(1)E7(2)	F5BBC3470(1)E7(2)
0.56	18	6.1	11.1	7.5	5.0	22	5BBC3560(1)B7(2)	F5BBC3560(1)B7(2)
0.56	18	6.1	11.1	7.5	5.0	27	5BBC3560(1)E7(2)	F5BBC3560(1)E7(2)
0.68	18	6.1	11.1	7.5	5.0	22	5BBC3680(1)B7(2)	F5BBC3680(1)B7(2)
0.68	18	6.1	11.1	7.5	5.0	27	5BBC3680(1)E7(2)	F5BBC3680(1)E7(2)
0.82	18	6.1	11.1	7.5	5.0	22	5BBC3820(1)B7(2)	F5BBC3820(1)B7(2)
0.82	18	6.1	11.1	7.5	5.0	27	5BBC3820(1)E7(2)	F5BBC3820(1)E7(2)
1.00	18	6.1	11.1	7.5	5.0	22	5BBC4100(1)B7(2)	F5BBC4100(1)B7(2)
1.00	18	6.1	11.1	7.5	5.0	27	5BBC4100(1)E7(2)	F5BBC4100(1)E7(2)
1.20	18	6.1	11.1	7.5	5.0	22	5BBC4120(1)B7(2)	F5BBC4120(1)B7(2)
1.20	18	6.1	11.1	7.5	5.0	27	5BBC4120(1)E7(2)	F5BBC4120(1)E7(2)
1.50	18	7.3	13.1	7.5	5.0	22	5BBC4150(1)B8(2)	F5BBC4150(1)B8(2)
1.50	18	7.3	13.1	7.5	5.0	27	5BBC4150(1)E8(2)	F5BBC4150(1)E8(2)
1.80	18	7.3	13.1	7.5	5.0	22	5BBC4180(1)B8(2)	F5BBC4180(1)B8(2)
1.80	18	7.3	13.1	7.5	5.0	27	5BBC4180(1)E8(2)	F5BBC4180(1)E8(2)
2.20	18	7.3	13.1	7.5	5.0	22	5BBC4220(1)B8(2)	F5BBC4220(1)B8(2)
2.20	18	7.3	13.1	7.5	5.0	27	5BBC4220(1)E8(2)	F5BBC4220(1)E8(2)
0.10	25	6.1	11.1	7.5	5.0	30	5BHC3100(1)A7(2)	F5BHC3100(1)A7(2)
0.10	25	6.1	11.1	7.5	5.0	33	5BHC3100(1)C7(2)	F5BHC3100(1)C7(2)
0.22	25	6.1	11.1	7.5	5.0	30	5BHC3220(1)A7(2)	F5BHC3220(1)A7(2)
0.22	25	6.1	11.1	7.5	5.0	33	5BHC3220(1)C7(2)	F5BHC3220(1)C7(2)
0.33	25	6.1	11.1	7.5	5.0	30	5BHC3330(1)A7(2)	F5BHC3330(1)A7(2)
0.33	25	6.1	11.1	7.5	5.0	33	5BHC3330(1)C7(2)	F5BHC3330(1)C7(2)
0.47	25	6.1	11.1	7.5	5.0	30	5BHC3470(1)A7(2)	F5BHC3470(1)A7(2)
0.47	25	6.1	11.1	7.5	5.0	33	5BHC3470(1)C7(2)	F5BHC3470(1)C7(2)
0.56	25	6.1	11.1	7.5	5.0	30	5BHC3560(1)A7(2)	F5BHC3560(1)A7(2)
0.56	25	6.1	11.1	7.5	5.0	33	5BHC3560(1)C7(2)	F5BHC3560(1)C7(2)
0.68	25	6.1	11.1	7.5	5.0	30	5BHC3680(1)A7(2)	F5BHC3680(1)A7(2)
0.68	25	6.1	11.1	7.5	5.0	33	5BHC3680(1)C7(2)	F5BHC3680(1)C7(2)
0.82	25	6.1	11.1	7.5	5.0	30	5BHC3820(1)A7(2)	F5BHC3820(1)A7(2)
0.82	25	6.1	11.1	7.5	5.0	33	5BHC3820(1)C7(2)	F5BHC3820(1)C7(2)
1.00	25	6.1	11.1	7.5	5.0	30	5BHC4100(1)A7(2)	F5BHC4100(1)A7(2)
1.00	25	6.1	11.1	7.5	5.0	33	5BHC4100(1)C7(2)	F5BHC4100(1)C7(2)
1.20	25	6.1	11.1	7.5	5.0	30	5BHC4120(1)A7(2)	F5BHC4120(1)A7(2)
1.20	25	6.1	11.1	7.5	5.0	33	5BHC4120(1)C7(2)	F5BHC4120(1)C7(2)
1.50	25	7.3	13.1	7.5	5.0	30	5BHC4150(1)A8(2)	F5BHC4150(1)A8(2)
1.50	25	7.3	13.1	7.5	5.0	33	5BHC4150(1)C8(2)	F5BHC4150(1)C8(2)
1.80	25	7.3	13.1	7.5	5.0	30	5BHC4180(1)A8(2)	F5BHC4180(1)A8(2)
1.80	25	7.3	13.1	7.5	5.0	33	5BHC4180(1)C8(2)	F5BHC4180(1)C8(2)
2.20	25	7.3	13.1	7.5	5.0	30	5BHC4220(1)A8(2)	F5BHC4220(1)A8(2)
2.20	25	7.3	13.1	7.5	5.0	33	5BHC4220(1)C8(2)	F5BHC4220(1)C8(2)
0.10	30	6.1	11.1	7.5	5.0	36	5BJC3100(1)D7(2)	F5BJC3100(1)D7(2)
0.10	30	6.1	11.1	7.5	5.0	39	5BJC3100(1)I7(2)	F5BJC3100(1)I7(2)
0.10	30	6.1	11.1	7.5	5.0	44	5BJC3100(1)N7(2)	F5BJC3100(1)N7(2)
0.22	30	6.1	11.1	7.5	5.0	36	5BJC3220(1)D7(2)	F5BJC3220(1)D7(2)
0.22	30	6.1	11.1	7.5	5.0	39	5BJC3220(1)I7(2)	F5BJC3220(1)I7(2)
0.22	30	6.1	11.1	7.5	5.0	44	5BJC3220(1)N7(2)	F5BJC3220(1)N7(2)
0.33	30	6.1	11.1	7.5	5.0	36	5BJC3330(1)D7(2)	F5BJC3330(1)D7(2)
0.33	30	6.1	11.1	7.5	5.0	39	5BJC3330(1)I7(2)	F5BJC3330(1)I7(2)
0.33	30	6.1	11.1	7.5	5.0	44	5BJC3330(1)N7(2)	F5BJC3330(1)N7(2)
0.47	30	6.1	11.1	7.5	5.0	36	5BJC3470(1)D7(2)	F5BJC3470(1)D7(2)
0.47	30	6.1	11.1	7.5	5.0	39	5BJC3470(1)I7(2)	F5BJC3470(1)I7(2)
0.47	30	6.1	11.1	7.5	5.0	44	5BJC3470(1)N7(2)	F5BJC3470(1)N7(2)

(1) Insert lead and packaging code. See Ordering Options Table for available options.

(2) Capacitance tolerance: K= ±10%, M = ±20%.

**Table 1 – Ratings & Part Number Reference cont.**

Capacitance Value (µF)	VDC	Max Dimensions in mm			Lead Spacing (S)	Diode Breakdown Voltage (VDC)	KEMET Part Number	Legacy Part Number
		T	H	L				
0.56	30	6.1	11.1	7.5	5.0	36	5BJC3560(1)D7(2)	F5BJC3560(1)D7(2)
0.56	30	6.1	11.1	7.5	5.0	39	5BJC3560(1)I7(2)	F5BJC3560(1)I7(2)
0.56	30	6.1	11.1	7.5	5.0	44	5BJC3560(1)N7(2)	F5BJC3560(1)N7(2)
0.68	30	6.1	11.1	7.5	5.0	36	5BJC3680(1)D7(2)	F5BJC3680(1)D7(2)
0.68	30	6.1	11.1	7.5	5.0	39	5BJC3680(1)I7(2)	F5BJC3680(1)I7(2)
0.68	30	6.1	11.1	7.5	5.0	44	5BJC3680(1)N7(2)	F5BJC3680(1)N7(2)
0.82	30	6.1	11.1	7.5	5.0	36	5BJC3820(1)D7(2)	F5BJC3820(1)D7(2)
0.82	30	6.1	11.1	7.5	5.0	39	5BJC3820(1)I7(2)	F5BJC3820(1)I7(2)
0.82	30	6.1	11.1	7.5	5.0	44	5BJC3820(1)N7(2)	F5BJC3820(1)N7(2)
1.00	30	6.1	11.1	7.5	5.0	36	5BJC4100(1)D7(2)	F5BJC4100(1)D7(2)
1.00	30	6.1	11.1	7.5	5.0	39	5BJC4100(1)I7(2)	F5BJC4100(1)I7(2)
1.00	30	6.1	11.1	7.5	5.0	44	5BJC4100(1)N7(2)	F5BJC4100(1)N7(2)
1.20	30	6.1	11.1	7.5	5.0	36	5BJC4120(1)D7(2)	F5BJC4120(1)D7(2)
1.20	30	6.1	11.1	7.5	5.0	39	5BJC4120(1)I7(2)	F5BJC4120(1)I7(2)
1.20	30	6.1	11.1	7.5	5.0	44	5BJC4120(1)N7(2)	F5BJC4120(1)N7(2)
1.50	30	7.3	13.1	7.5	5.0	36	5BJC4150(1)D8(2)	F5BJC4150(1)D8(2)
1.50	30	7.3	13.1	7.5	5.0	39	5BJC4150(1)I8(2)	F5BJC4150(1)I8(2)
1.50	30	7.3	13.1	7.5	5.0	44	5BJC4150(1)N8(2)	F5BJC4150(1)N8(2)
1.80	30	7.3	13.1	7.5	5.0	36	5BJC4180(1)D8(2)	F5BJC4180(1)D8(2)
1.80	30	7.3	13.1	7.5	5.0	39	5BJC4180(1)I8(2)	F5BJC4180(1)I8(2)
1.80	30	7.3	13.1	7.5	5.0	44	5BJC4180(1)N8(2)	F5BJC4180(1)N8(2)
2.20	30	7.3	13.1	7.5	5.0	36	5BJC4220(1)D8(2)	F5BJC4220(1)D8(2)
2.20	30	7.3	13.1	7.5	5.0	39	5BJC4220(1)I8(2)	F5BJC4220(1)I8(2)
2.20	30	7.3	13.1	7.5	5.0	44	5BJC4220(1)N8(2)	F5BJC4220(1)N8(2)
0.10	45	6.1	11.1	7.5	5.0	53	5BNC3100(1)B7(2)	F5BNC3100(1)B7(2)
0.22	45	6.1	11.1	7.5	5.0	53	5BNC3220(1)B7(2)	F5BNC3220(1)B7(2)
0.33	45	6.1	11.1	7.5	5.0	53	5BNC3330(1)B7(2)	F5BNC3330(1)B7(2)
0.47	45	6.1	11.1	7.5	5.0	53	5BNC3470(1)B7(2)	F5BNC3470(1)B7(2)
0.56	45	6.1	11.1	7.5	5.0	53	5BNC3560(1)B7(2)	F5BNC3560(1)B7(2)
0.68	45	6.1	11.1	7.5	5.0	53	5BNC3680(1)B7(2)	F5BNC3680(1)B7(2)
0.82	45	6.1	11.1	7.5	5.0	53	5BNC3820(1)B7(2)	F5BNC3820(1)B7(2)
1.00	45	6.1	11.1	7.5	5.0	53	5BNC4100(1)B7(2)	F5BNC4100(1)B7(2)
1.20	45	6.1	11.1	7.5	5.0	53	5BNC4120(1)B7(2)	F5BNC4120(1)B7(2)
1.50	45	7.3	13.1	7.5	5.0	53	5BNC4150(1)B8(2)	F5BNC4150(1)B8(2)
1.80	45	7.3	13.1	7.5	5.0	53	5BNC4180(1)B8(2)	F5BNC4180(1)B8(2)
2.20	45	7.3	13.1	7.5	5.0	53	5BNC4220(1)B8(2)	F5BNC4220(1)B8(2)
0.10	50	6.1	11.1	7.5	5.0	68	5BCC3100(1)C7(2)	F5BCC3100(1)C7(2)
0.22	50	6.1	11.1	7.5	5.0	68	5BCC3220(1)C7(2)	F5BCC3220(1)C7(2)
0.33	50	6.1	11.1	7.5	5.0	68	5BCC3330(1)C7(2)	F5BCC3330(1)C7(2)
0.47	50	6.1	11.1	7.5	5.0	68	5BCC3470(1)C7(2)	F5BCC3470(1)C7(2)
0.56	50	6.1	11.1	7.5	5.0	68	5BCC3560(1)C7(2)	F5BCC3560(1)C7(2)
0.68	50	6.1	11.1	7.5	5.0	68	5BCC3680(1)C7(2)	F5BCC3680(1)C7(2)
0.82	50	6.1	11.1	7.5	5.0	68	5BCC3820(1)C7(2)	F5BCC3820(1)C7(2)
1.00	50	6.1	11.1	7.5	5.0	68	5BCC4100(1)C7(2)	F5BCC4100(1)C7(2)
1.20	50	6.1	11.1	7.5	5.0	68	5BCC4120(1)C7(2)	F5BCC4120(1)C7(2)
1.50	50	7.3	13.1	7.5	5.0	68	5BCC4150(1)C8(2)	F5BCC4150(1)C8(2)
1.80	50	7.3	13.1	7.5	5.0	68	5BCC4180(1)C8(2)	F5BCC4180(1)C8(2)
2.20	50	7.3	13.1	7.5	5.0	68	5BCC4220(1)C8(2)	F5BCC4220(1)C8(2)
0.10	63	6.1	11.1	7.5	5.0	82	5BDC3100(1)C7(2)	F5BDC3100(1)C7(2)
0.22	63	6.1	11.1	7.5	5.0	82	5BDC3220(1)C7(2)	F5BDC3220(1)C7(2)
0.33	63	6.1	11.1	7.5	5.0	82	5BDC3330(1)C7(2)	F5BDC3330(1)C7(2)
0.47	63	6.1	11.1	7.5	5.0	82	5BDC3470(1)C7(2)	F5BDC3470(1)C7(2)
0.56	63	6.1	11.1	7.5	5.0	82	5BDC3560(1)C7(2)	F5BDC3560(1)C7(2)
0.68	63	6.1	11.1	7.5	5.0	82	5BDC3680(1)C7(2)	F5BDC3680(1)C7(2)
0.82	63	6.1	11.1	7.5	5.0	82	5BDC3820(1)C7(2)	F5BDC3820(1)C7(2)
1.00	63	6.1	11.1	7.5	5.0	82	5BDC4100(1)C7(2)	F5BDC4100(1)C7(2)
1.20	63	6.1	11.1	7.5	5.0	82	5BDC4120(1)C7(2)	F5BDC4120(1)C7(2)
1.50	63	7.3	13.1	7.5	5.0	82	5BDC4150(1)C8(2)	F5BDC4150(1)C8(2)
1.80	63	7.3	13.1	7.5	5.0	82	5BDC4180(1)C8(2)	F5BDC4180(1)C8(2)
2.20	63	7.3	13.1	7.5	5.0	82	5BDC4220(1)C8(2)	F5BDC4220(1)C8(2)
Capacitance Value (µF)	VDC	T (mm)	H (mm)	L (mm)	Lead Spacing (S)	Diode Breakdown Voltage (VDC)	KEMET Part Number	Legacy Part Number

(1) Insert lead and packaging code. See Ordering Options Table for available options.

(2) Capacitance tolerance: K= ±10%, M = ±20%.

## Maximum Soldering Temperature

In order to achieve optimal solderability, we suggest the following:

- Set the temperature so that the maximum temperature inside the element is below 160°C.
- Solder within the following temperature profiles, especially for iron soldering:

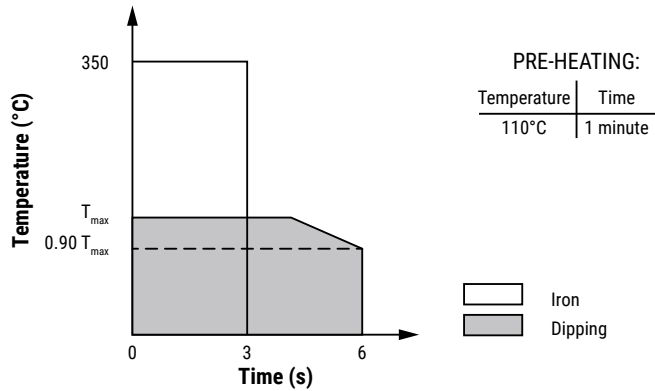

## General Conditions

- If two solderings are required, allow for recovery time until the temperature on the capacitor surface is below 50°C.
- Avoid passing through the adhesive curing oven when fixing surface-mount parts in combination with through-hole parts. Insert through-hole parts only after curing the surface-mount parts.
- Avoid reflow soldering by combining the lead type with surface-mount parts.



## Marking

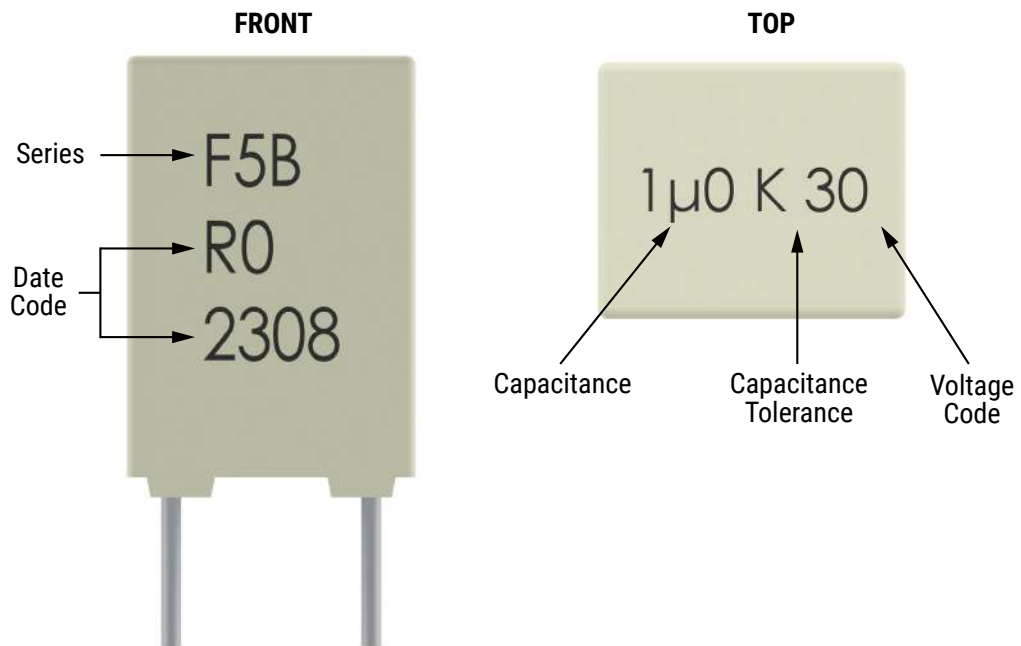

## Packaging Quantities

Lead Spacing	Thickness (mm)	Height (mm)	Length (mm)	Bulk Short Leads	Bulk Long Leads	Standard Reel 355 mm	Ammo
5	4.6	9.6	7.4	1,500	2,000	1,400	1,900
	5.1	10.1	7.5	1,000	1,500	1,200	1,700
	6.1	11.1	7.5	2,000	1,000	1,000	1,400
	7.3	13.1	7.5	1,500	750	800	1,150

## Lead Taping & Packaging (IEC 60286-2)

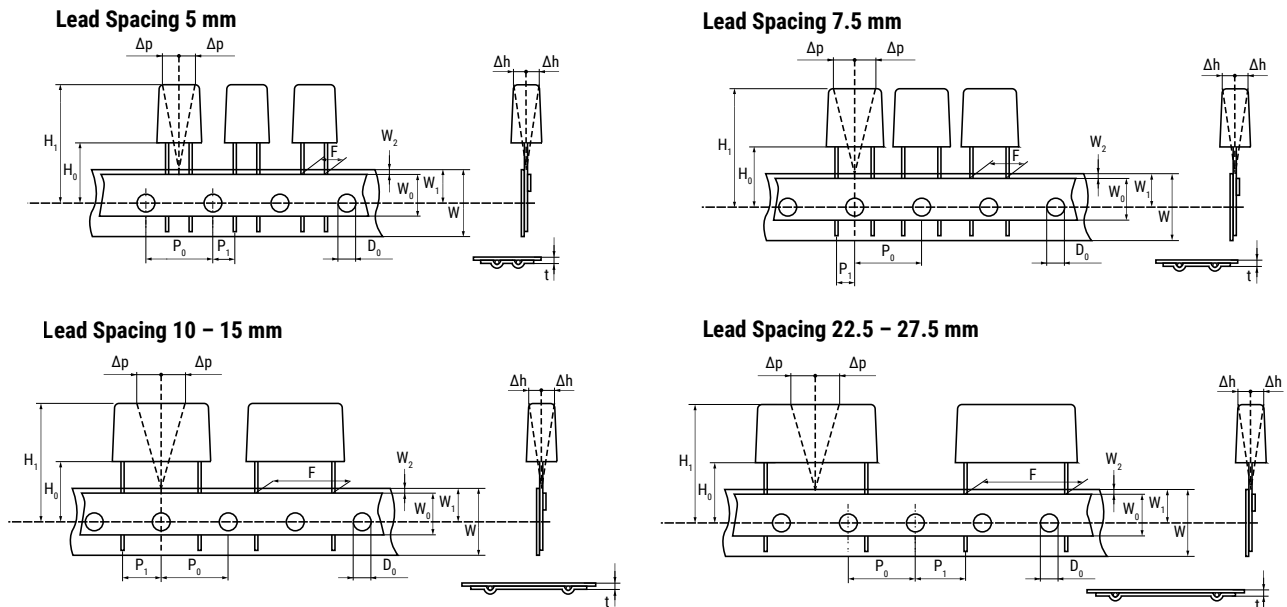

## Taping Specification

Dimensions in mm									Standard IEC 60286-2
Lead Spacing	+0.6/-0.1	F	5.0	7.5	10.0	15.0	22.5	27.5	F
Carrier Tape Width	+1/-0.5	W	18.0	18.0	18.0	18.0	18.0	18.0	18 <sup>+1/-0.5</sup>
Hold-Down Tape Width	Minimum	W <sub>0</sub>	6.0	6.0	9.0	10.0	10.0	10.0	
Position of Sprocket Hole	±0.5	W <sub>1</sub>	9.0	9.0	9.0	9.0	9.0	9.0	9 <sup>+0.75/-0.5</sup>
Distance Between Tapes	Maximum	W <sub>2</sub>	3.0	3.0	3.0	3.0	3.0	3.0	3.0
Sprocket Hole Diameter	±0.2	D <sub>0</sub>	4.0	4.0	4.0	4.0	4.0	4.0	4.0
Feed Hole Lead Spacing	±0.2 <sup>(1)</sup>	P <sub>0</sub> <sup>(3)</sup>	12.7	12.7	12.7	12.7	12.7	12.7	12.7
Distance Lead – Feed Hole	±0.7	P <sub>1</sub>	3.85	3.75	7.7	5.2	7.8	5.3	P <sup>1</sup>
Deviation Tape – Plane	Maximum	Δp	1.3	1.3	1.3	1.3	1.3	1.3	1.3
Lateral Deviation	±2	Δh	2.0	2.0	2.0	2.0	2.0	2.0	2.0
Total Thickness	±0.2	t	0.7	0.7	0.7	0.7	0.9 <sup>MAX</sup>	0.9 <sup>MAX</sup>	0.9 <sup>MAX</sup>
Sprocket Hole/Cap Body	±0.5	H <sub>0</sub> <sup>(2)</sup>	18.5 <sup>±0.5</sup>	18.5 <sup>±0.5</sup>	18.5 <sup>±0.5</sup>	18.5 <sup>±0.5</sup>	18.5 <sup>±0.5</sup>	18.5 <sup>±0.5</sup>	18 <sup>+2/-0</sup>

(1) Maximum cumulative feed hole error, 1 mm per 20 parts.

(2) 16.5 mm available on request.

(3) 15 mm available on request (F ≥ 10 mm).

## Lead Taping & Packaging (IEC 60286-2) cont.

### Ammo Specifications

Series	Dimensions (mm)		
	H	W	T
F5A, F5B, F5D	360	340	59
F6xx, F8xx			
PHExxx, PMExxx, PMRxxx	330	330	50

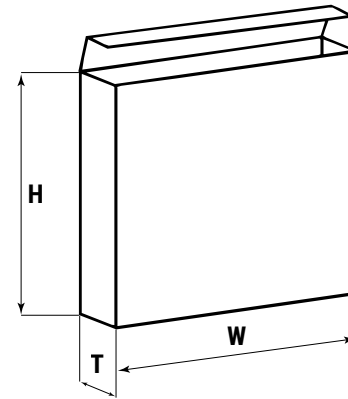

### Reel Specifications

Series	Dimensions (mm)		
	D	H	W
F5A, F5B, F5D	355	30	55 (Max)
F6xx, F8xx	500	25	
PHExxx, PMExxx, PMRxxx	360	30	46 (Max)
	500		

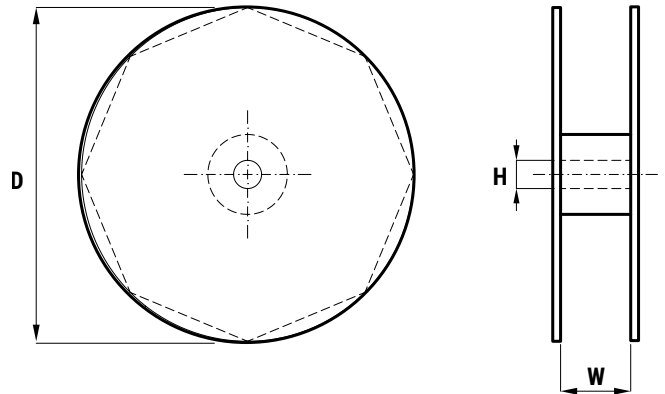

## KEMET Electronics Corporation Sales Offices

For a complete list of our global sales offices, please visit [www.kemet.com/sales](http://www.kemet.com/sales).

---

### Disclaimer

YAGEO Corporation and its affiliates do not recommend the use of commercial, automotive, and/or COTS grade products for high reliability applications or manned space flight.

All product specifications, statements, information and data (collectively, the "Information") in this datasheet are subject to change. The customer is responsible for checking and verifying the extent to which the Information contained in this publication is applicable to an order at the time the order is placed. All Information given herein is believed to be accurate and reliable, but it is presented without guarantee, warranty, or responsibility of any kind, expressed or implied.

Statements of suitability for certain applications are based on KEMET Electronics Corporation's ("KEMET") knowledge of typical operating conditions for such applications, but are not intended to constitute – and KEMET specifically disclaims – any warranty concerning suitability for a specific customer application or use. The Information is intended for use only by customers who have the requisite experience and capability to determine the correct products for their application. Any technical advice inferred from this Information or otherwise provided by KEMET with reference to the use of KEMET's products is given gratis, and KEMET assumes no obligation or liability for the advice given or results obtained.

Although KEMET designs and manufactures its products to the most stringent quality and safety standards, given the current state of the art, isolated component failures may still occur. Accordingly, customer applications which require a high degree of reliability or safety should employ suitable designs or other safeguards (such as installation of protective circuitry or redundancies) in order to ensure that the failure of an electrical component does not result in a risk of personal injury or property damage.

**Warning: The component F5B is a combined passive suppression component. Overloading with high voltage or voltage transients can strongly damage the component with the risk of fire.** Although all product-related warnings, cautions and notes must be observed, the customer should not assume that all safety measures are indicated or that other measures may not be required.