

1 Appearance

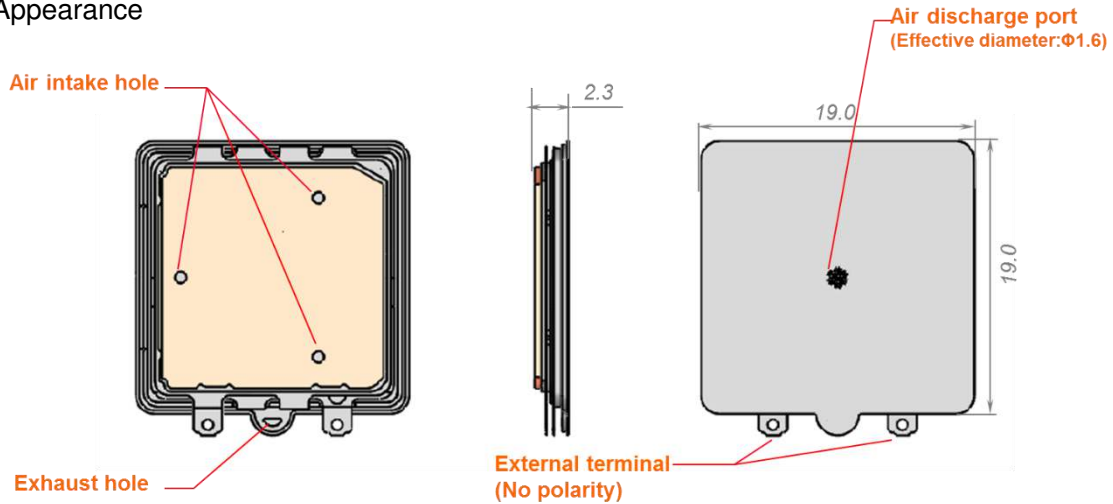

Table. 1-1

Item	Specificaton	Condition
Outside dimension/tolerance	19±0.15mm	Except the terminal
Thickness/tolerance	2.3±0.2mm	

2 Ratings

Table.2-1

Rating	Value	Unit	Condition
Operating Voltage Range	8 to 18 ※1-1	Vdc	Back pressure < 10kPa
	8 to 19.5 ※1-1	Vdc	Back pressure ≥ 10kPa
Environmental Operating Temperature Range	0 to +45 ※1-2	°C	-

※1-1 Voltage to be applied to recommended driver circuit.

Less than 8Vdc driving may be occurred oscillation failure.

The pump can be driven by a voltage of 18 Vdc or more, only in the case where the back pressure is +10 kPa.

If the back pressure is less than +10 kPa, and in addition the pump is driven by a voltage of 18 Vdc or more, there is a possibility of a breakdown occurring.

※1-2 Pump's performance may decrease by self heating.

Please use it in its metal surface (Marking side) temperature less than or equal to 60°C.

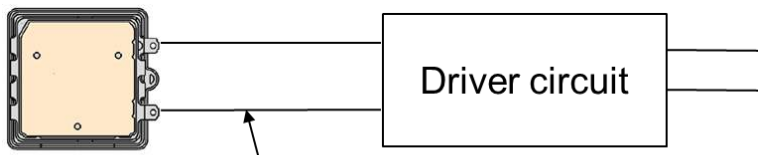

It is recommended that the customer solder the external wiring.

3 Performance

3.1 Air Performance

Table. 3-1

Item	Specification	Condition
Free Flow Rate @18Vdc	≥ 155 ml/min	Ambient temperature:18 to 28°C Relative humidity: 25 to 85%RH Atmospheric pressure: 950 to 1020 hPa
Static Pressure @19.5Vdc	≥ 50 kPa	

3.2 Electrical Performance

Table. 3-2

Item	Specification	Condition
Drive Resonant Frequency	21.5 to 24.5kHz	

Note:

This catalog is for reference only and not an official product specification document, therefore, please review and approve our official product specification before ordering this product.

4 Typical Characteristic ※4-1

Table. 4-1

Item	
Free Flow Rate (0kPa) @18Vdc	200ml/min
Power consumption @Free Flow Rate 18Vdc	0.8W
Static Pressure (0ml/min) @19.5Vdc	60kPa
Power consumption @Static Pressure 19.5Vdc	1.1W
Exhaust time ※4-2	≤ 10 sec
Drive Resonant Frequency	23kHz

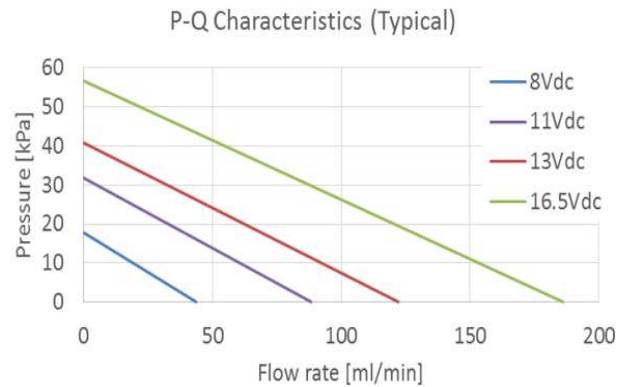

※4-1 There are not guaranteed values.

※4-2 Time during which the pressure in the 100cc tank connected to MZB3004T04 which is connected to 100cc tank falls from 260mmHg to 15mmHg when the MZB3004T04 is turned off.

5 Test Result

※The following test results are only experimental results and are not guaranteed.

5.1 Physical Stress Test

Table. 5-1

Item	Test Condition	Number	Result
Vibration	Applying the vibration of maximum amplitude 1.5mm and vibration frequency 10 to 55Hz/10G in each of 3 perpendicular directions for 5min x 24 times. Sweep method:log	10	G
Shock	100G/6msec, Applying the shock of 100G 3 times for six aspects.	10	G
Free Drop	30 cm height, wood floor, 3 times	10	G
Outer Terminal Strength	(1) Pull Test force 2.5N, tensile direction is horizontal direction for terminal,time-of-stressing 10 seconds (2) Bend Bending direction is vertical direction (+0° , -90°) for terminal. Marking side is + direction. Time-of-stressing is 2-3 seconds	Each direction 10	G

Judgement condition:

After test, characteristics of table 3-1 and table 3-2 are within spec or variation in the characteristics is within 15%

5.2 Strage Test

Table. 5-2

Item	Test Condition	Number	Result
Cold	Pump shall be left in a chamber (Temperature:-40±2°C) for 500 hours, then measured after leaving in natural condition for 2 hours.	10	G
Dry Heat	Pump shall be left in a chamber (Temperature:+70±2°C,65±5%RH) for 500 hours, then measured after leaving in natural condition for 2 hours.	10	G
Humidity	Pump shall be left in a chamber (95±5%R.H.at +55±2°C) for 500 hours, then measured after leaving in natural condition for 2 hour.	10	G
Thermal schock test	Test temperature -25±3 °C / 60±2 °C, Test time 30 min/, 30 min, 500 cycles tested, then measured after leaving in natural condition for 2 hours.	10	G

Note) At Murata test condition

Judgement condition:

After test, characteristics of table 3-1 and table 3-2 are within spec or variation in the characteristics is within 20%.

5.3 Driving Test

Table. 5-3

Item	Test Condition	Number	Result
Continuous Driving Test 1	Drive Voltage:16.5Vdc Drive mode:Pressure mode (Closed space) In crean room Driving period:500hr Environmental temperature:Room temperature	5	G
Continuous Driving Test 2	Drive Voltage:16.5Vdc Drive mode:Flow mode (Opened space) In crean room Driving period:500hr Environmental temperature:Room temperature	5	G

Note) At Murata test condition

The metal surface (Marking side) temperature of the products was 60 ° C or less when driven under the above conditions.

Judgement condition:

After test, characteristics of table 3-1 and table 3-2 are within spec or variation in the characteristics is within 20%.

6 Dimensions

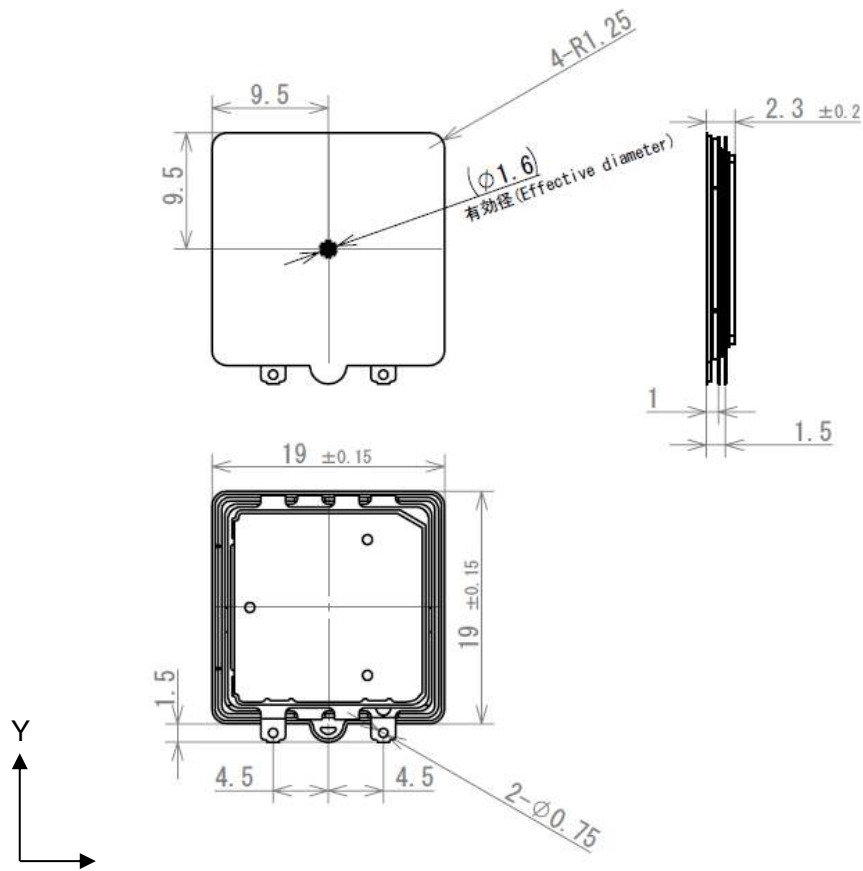

※ The dimensions without tolerances shown in the following figure are reference values.

7 Printing

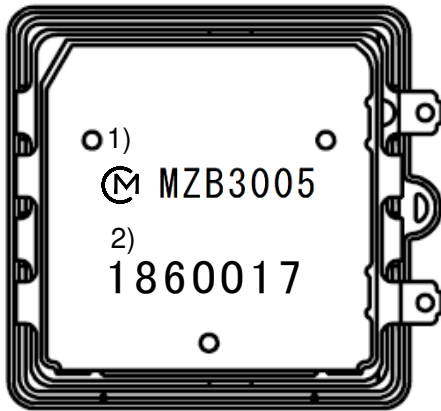

1. Company symbol () and Parts number: MZB3005

2. Lot no.: 7 letters

- (1) Year : the last 2 digits of the year
- (2) Month : 1~9, X:Oct., Y:Nov., Z:Dec.
- (3) Lot No : 0001~9999

The serial number each lot
 • Parts number details

Ex.)2018. June lot

18	6	0017
(1)	(2)	(3)

laser marking above letters

•Parts number details

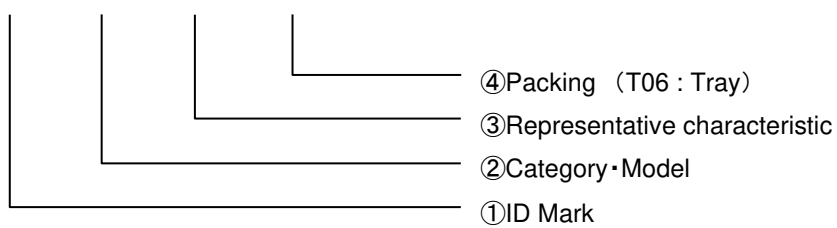
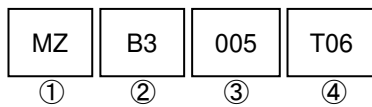

8 Packing Standard
8.1 Dimensions of Tray

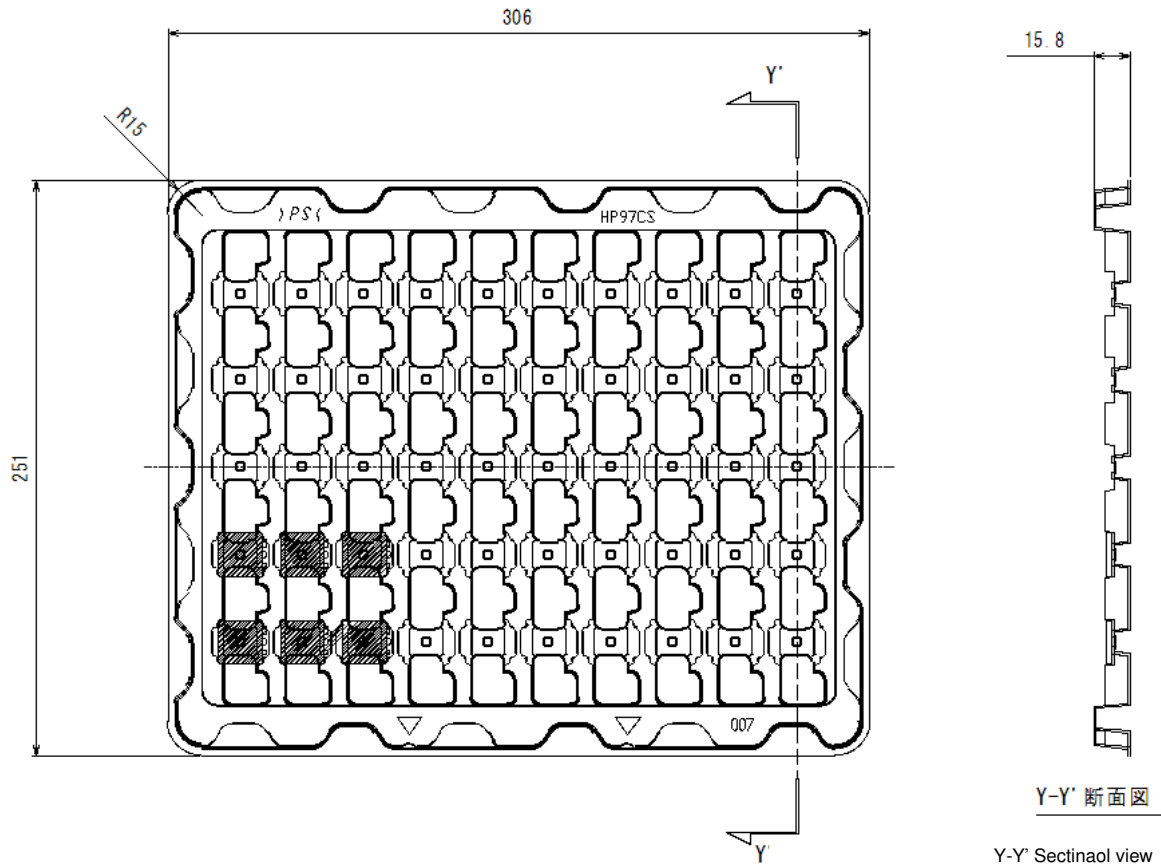

Y-Y' 断面图

Y-Y' Sectional view

8.2 Packaging Form

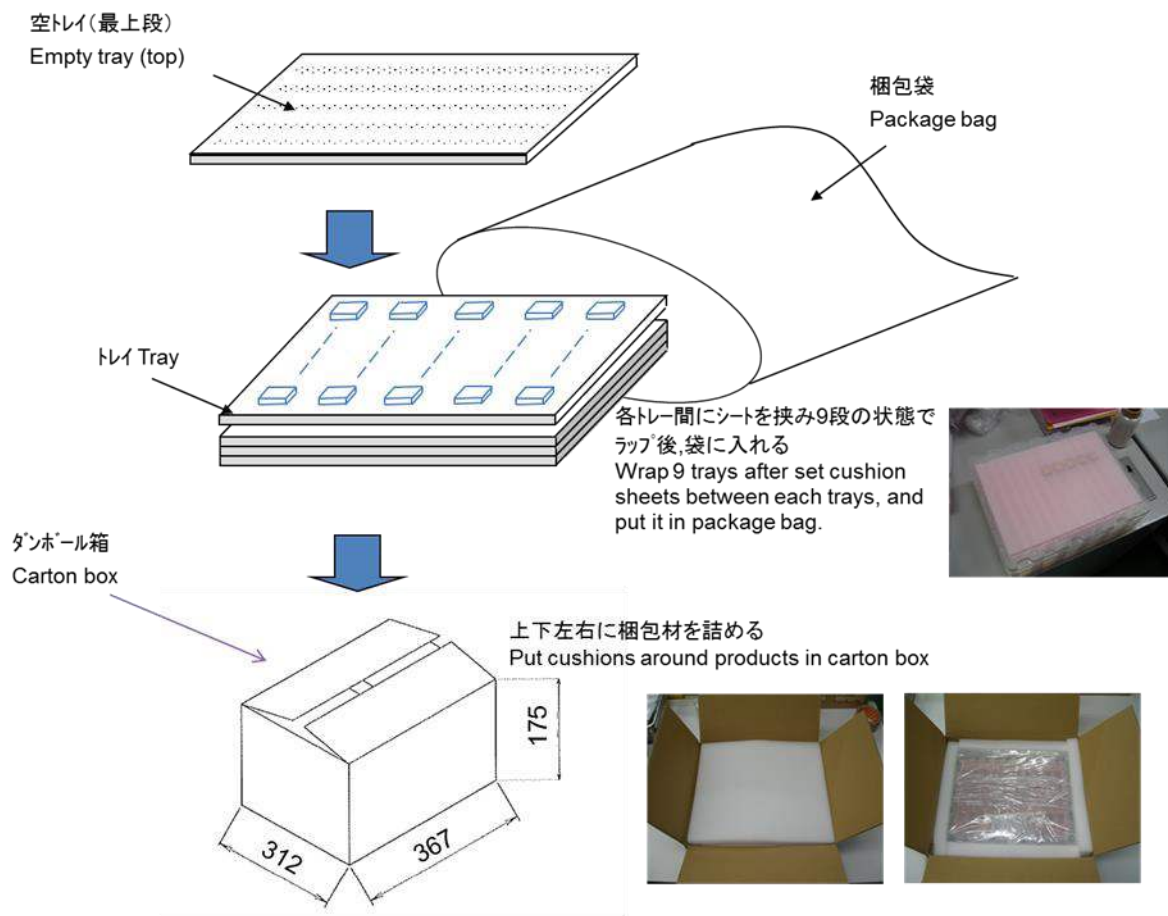

8.3 The Quantity per a box

Packaging Quantity: 400 pieces max. (= 50 pieces /tray x 8 trays)

However, total number of tray is 9 trays because empty tray is set on the top

Maximum 3 Lot mix/carton box

8.4 Content of Outer Label

The minimum packaging unit shall be a box. Each minimum package unit of pumps shall be in a carton box and it shall be clearly marked with your company name, customer's and Murata's part numbers, quantity and so on.

9. Considerations for soldering

9.1 Wiring

Lead wire should be through from back side terminal hole to top side.
And soldering is enough to treat top side only.

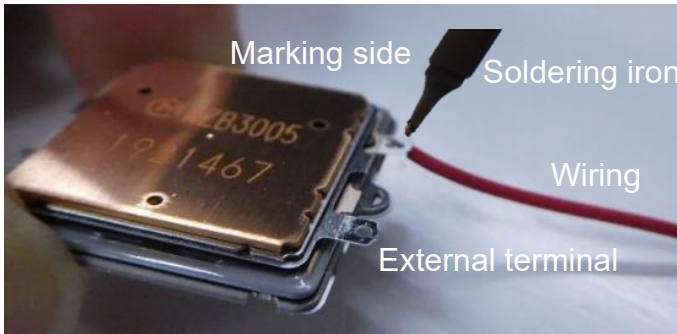

9-2. Condition for soldering

Please solder the sample by using the soldering iron, and please don't touch the housing directly.

Soldering Conditions	
Temperature of iron	≤350°C
Contact time	≤3Sec / each terminal
Note	less than 3 cycle (350°C,3sec(max.) /cycle)

Note) Please careful excessive terminal bent.
To avoid trouble, please keep bending force to terminal 2.5N or less.

10.  Cautions

10-1 Limitation of applications

The products are designed and produced for application in ordinary electronic equipment (AV equipment, OA equipment, telecommunication, etc). If the products are to be used in devices requiring extremely high reliability following the application listed below, you should consult with the Murata staff in advance.

- Aircraft equipment.
- Aerospace equipment
- Undersea equipment.
- Power plant control equipment.
- Medical equipment.
- Transportation equipment (vehicles, trains, ships, etc.).
- Traffic signal equipment.
- Disaster prevention / crime prevention equipment.
- Data-processing equipment.
- Application which malfunction or operational error may endanger human life and property of assets.
- Application which related to occurrence the serious damage
- Application of similar complexity and/ or reliability requirements to the applications listed in the above.

10-2 Fail-safe

If product malfunctions may result in serious damage, including that to human life, sufficient fail-safe measures must be taken, including the following:

- (1) Installation of protection circuits or other protective device to improve system safety
- (2) Installation of redundant circuits in the case of single-circuit failure

11 Instruction for use

- 11-1. Our company doesn't bear any responsibility with respect to problems connecting the product with your equipment.
- 11.2 Since the product sucks and discharges air, contaminants and dust in the air tend to accumulate inside the pump, and the contaminants and dust will influence the operation time. Use the product in a clean environment, or use a filter to remove at least submicron level of contaminants to prevent particles and dust from entering.
(※The use of filter does not guarantee suppression of the characteristics deterioration of the product.) Our company doesn't bear any responsibility with respect to the problems.
- 11.3 Please do not touch the component (included nozzle, Outer terminal.) with bare hands.
- 11.4 Applying load on the product during operation may cause characteristics drop or sound noise generation. And more, when you push the center of a body temporarily at the time of assembly, etc., please do not apply load more than 1kgf (10N).
- 11.5 Don't bend the external terminal to the marking side because there is a possibility of the terminal breaking.
- 11.6 Please refrain from using the product under the condensation environment.
- 11.7 When the drive of the product is stopped while it is connected to it with the container of 10cc or less, the noisy may occur. But it isn't a defect.
- 11.8 Please pay attention to protect operating circuit from surge voltage provided by something
- 11.9 Please pay attention never to apply DC voltage and over 100mA current to the product.
- 11.10 Washing of the component is not acceptable, because it is not sealed.
- 11.11 Automatic mounting (SMT) is not acceptable.
- 11.12 No effect for the performance even if there are scratches on appearance and tarnishes of material.
- 11.13 Please take electrostatic countermeasure with wrist band etc.

12 Notice on Storage

12.1 Please store the products in room where the temperature/humidity is stable. And avoid such places where there are large temperature changes. Please store the products.

Under the following conditions : Temperature -10 to +40 deg

Humidity 10 to 85% RH

12.2 Expire date (Shelf life) of the products is 6 months after delivery under the conditions of a sealed and an unopened package. Please use the products within 6 months after delivery. If you store the products for a long time (more than 6months), use carefully because the products may be degraded in the solder-ability and/or rusty. Please confirm solder-ability and characteristics for the products regularly

12.3 Please do not store the products in a chemical atmosphere (Acids, Alkali, Bases, Organic gas, Sulfides and so on), because the characteristics may be reduced in quality, and/or be degraded in the solder-ability due to the storage in a chemical atmosphere.

12.4 Please do not put the products directly on the floor without anything under them to avoid damp places and/or dusty places

12.5 Please do not store the products in the places such as : in a damp heated place, in a place where direct sunlight comes in, in place applying vibrations.

12.6 Please use the products immediately after the package is opened, because the characteristics may be reduced in quality, and/or be degraded in the solder-ability due to storage under the poor condition.

12.7 Please do not drop products to avoid cracking of ceramic element.

13 Note

- 13.1 Please make sure that your product has been evaluated and confirmed against your specifications when our product is mounted to your product.
- 13.2 Product specifications are subject to change or our products in it may be discontinued without advance notice.
- 13.3 This catalog is for reference only and not an official product specification document, therefore, please review and approve our official product specification before ordering this product.

(Reference material)

Recommended circuit driver

Schematic

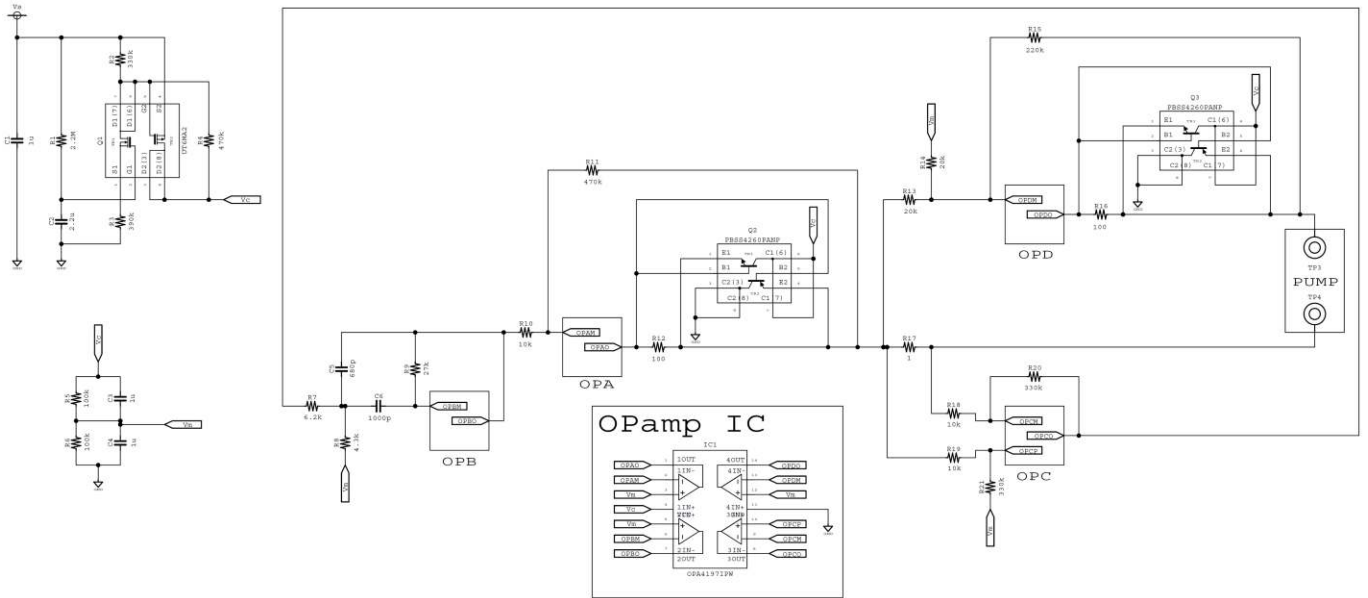

BOM

PartsCategory	PartsName	Sum	VendorName	Value	M-Rated	Reference	note
OPAMP	OPA4197IPWR	1	TI	-	-	IC1	-
MOSFET	UT6MA2TCR	1	ROHM	-	-	Q1	-
TRANSISTOR	PBSS4260PANP	2	NXP	-	-	Q2,Q3	-
RESISTOR	RK73B1ETTP225J	1	KOA	2.2M	0.1W	R1	±5%
RESISTOR	RK73B1ETTP334J	3	KOA	330k	0.1W	R2,R20,R21	±5%
RESISTOR	RK73B1ETTP394J	1	KOA	390k	0.1W	R3	±5%
RESISTOR	RK73B1ETTP474J	2	KOA	470k	0.1W	R4,R11	±5%
RESISTOR	RK73B1ETTP104J	2	KOA	100k	0.1W	R5,R6	±5%
RESISTOR	RK73B1ETTP622J	1	KOA	6.2k	0.1W	R7	±5%
RESISTOR	RK73B1ETTP432J	1	KOA	4.3k	0.1W	R8	±5%
RESISTOR	RK73H1ETTP2702F	1	KOA	27k	0.1W	R9	±1%
RESISTOR	RK73B1ETTP103J	3	KOA	10k	0.1W	R10,R18,R19	±5%
RESISTOR	RK73B1ETTP101J	2	KOA	100	0.1W	R12,R16	±5%
RESISTOR	RK73B1ETTP203J	2	KOA	20k	0.1W	R13,R14	±5%
RESISTOR	RK73B1ETTP224J	1	KOA	220k	0.1W	R15	±5%
RESISTOR	RK73B1ETTP1R0J	1	KOA	1	0.1W	R17	±5%
CAPACITOR	GRM155R6YA105KE11D	3	MURATA	1u	35V	C1,C3,C4	±10%
CAPACITOR	GRM155R61E225KE11D	1	MURATA	2.2u	25V	C2	±10%
CAPACITOR	GRM1552C1H681FA01D	1	MURATA	680p	50V	C5	±1%
CAPACITOR	GRM1552C1H102FA01D	1	MURATA	1000p	50V	C6	±1%

Notes on connecting with your equipment

- Our company doesn't bear any responsibility with respect to problems connecting the product with your equipment.
- We recommend the use of double-sided tape about connecting the product with your equipment. We recommend that you attach the double-sided tape to your equipment first.
- Please don't apply load more than 10N when you push toe center of a body.
- We recommend a metal for the material of the adhered part. If you use a resin, please use a low water absorbent resin.
- Be less than equal to $\Phi 3.0\text{mm}$ about the diameter of center in order to reduce the pressure receiving area. But be bigger than $\Phi 1.6\text{mm}$ to avoid fixing to air discharge port.
- Avoid fixing to four corners of our product.

(The vibrations of the piezoelectric element are propagated to them. If they are fixed, the state of vibrations will change and the performance of our product will decrease.)

