



Instructions atmospheric pressure transmitter (485 type) V1.0

# **RS-QY-N01-2-4**

## **Atmospheric pressure Transmitter user's Guide (485 type)**

Document version: V1.0



Instructions atmospheric pressure transmitter (485 type) V1.0





## Context

1. Introduction.....	4
1.1 Product Overview .....	4
1.2 Features .....	4
1.3 Main Specifications.....	4
1.4 Product Selection .....	5
1.5 System frame diagram.....	5
2. Installation instructions .....	5
2.1 Equipment installation check .....	6
2.2 Interface Description.....	6
2.3 electrical wiring.....	6
2.4 Description field wiring 485 .....	6
3. Configure the software installation and use .....	6
3.1 Software Selection .....	6
3.2 parameter settings .....	6
4. Communication Protocol .....	9
4.1 The basic parameters of Communications .....	9
4.2 Frame format definition data.....	9
4.3 Register Address .....	9
4.4 protocol examples and explanation.....	10
5. Common Problems and Solutions .....	10
5.1 device can not connect to a PLC or PC.....	10
6. Contact.....	11
7. Document History .....	11
8. Size housing.....	11



# 1. Introduction

## 1.1 Product Overview

RS-QY-N01-2 atmospheric pressure transmitter made of imported high-precision measuring means, high-accuracy temperature compensation device, high stability, low drift high repeatability; easy selection of wall-mounted housing is fixed to the wall. Need accommodation suitable temperature measuring barometric pressure monitoring and small weather station, altimeter, agricultural greenhouses, archives and the like.

## 1.2 Features

Wide DC supply voltage 10-30V

Standard ModBus-RTU protocol

Atmospheric pressure and temperature measured simultaneously

0-120Kpa wide pressure range, can be applied to various altitudes

## 1.3 Main Specifications

DC power supply (default)	10 ~ 30V DC	
Accuracy	Air pressure	$\pm 0.15\text{Kpa}@25\text{ }^{\circ}\text{C}$ 75Kpa
	temperature	$\pm 0.5\text{ }^{\circ}\text{C}$ (25 $^{\circ}\text{C}$ ) (default)
Transmitter circuit operating temperature	-20 $^{\circ}\text{C}$ ~ + 60 $^{\circ}\text{C}$ , 0 % RH ~ 80% RH	
Measuring medium	air	
Measuring range	Air pressure	0 ~ 120Kpa
	temperature	-40 $^{\circ}\text{C}$ ~ 80 $^{\circ}\text{C}$ (customizable)
Long - term stability	Air pressure	-0.1Kpa / Year
	temperature	$\leq 0.1\text{ }^{\circ}\text{C}$ / Year
Response time	$\leq 1\text{S}$	
output signal	485 (modbus) protocol Baud Rate: 2400, 4800 (default), 9600 Data bit length: 8	



	Parity mode: none Stop bit length: 1 The default ModBus Address: 1 Support Function code: 03
Parameter configuration	Software configuration
Power consumption	≤ 0.5W

### 1.4 Product Selection

RS-			Ren Shuo company code
	QY -		Atmospheric pressure transmitter
		N01-	485 (modbus) protocol
			2-4
			Probe built-in

### 1.5 System frame diagram

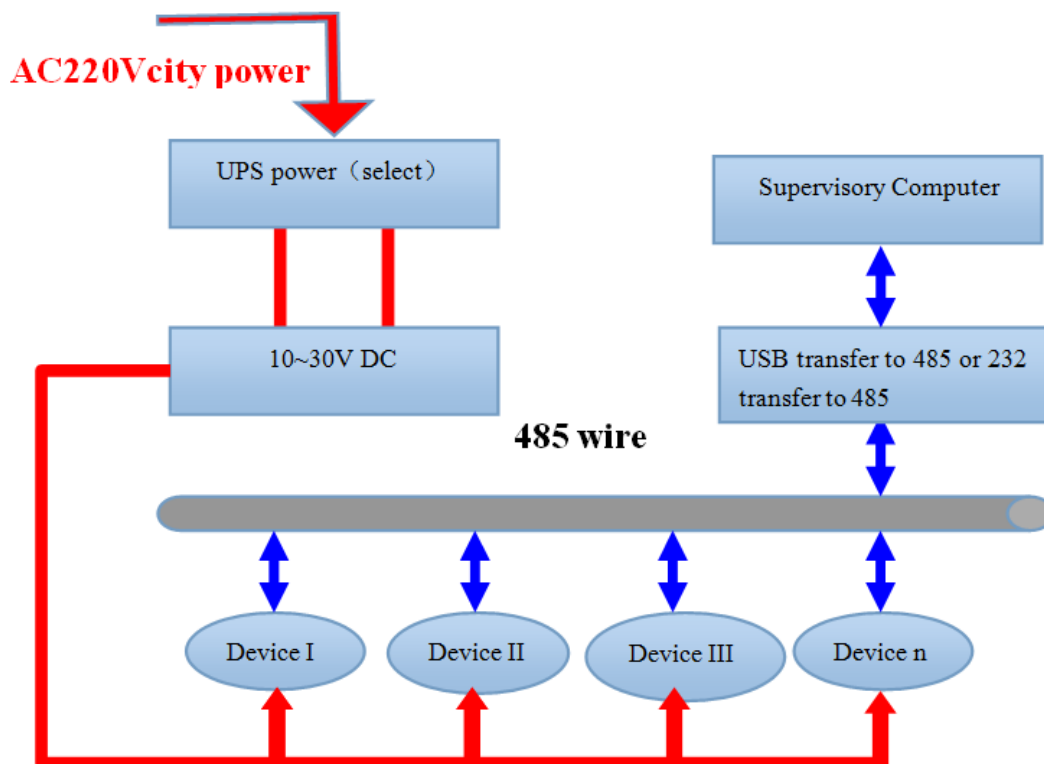

## 2. Installation instructions



## 2.1 Equipment installation check

Equipment List:

- transmitter equipment 1
- certificate, warranty card, service card, etc.
- 12V / 2A 1 water supply station (optional)
- USB to 485 (optional)
- 485 terminating resistor (optional)

## 2.2 Interface Description

Wide voltage power input 10 ~ 30 V can. Note that the signal line wiring 485 A / B two lines can not be reversed, the address bus between multiple devices must not conflict.

## 2.3 electrical wiring

	Line color	Description
Electricity source	brown	A positive power supply (10 ~ 30 V DC)
	black	Negative power supply
through letter	yellow	485 -A
	blue	485 -B

## 2.4 Description field wiring 485

When a plurality of types of devices 485 connected to the same bus, the field wiring have certain requirements, refer to the specific data packet "485 field wiring device manual."

## 3. Configure the software installation and use

### 3.1 Software Selection

Opening the datagram, and choosing “test software” ---- “485 parameter setting software”

and finding out  485参数配置工具 control KTControl Micros... and opening it.

### 3.2 parameter settings



## Instructions atmospheric pressure transmitter (485 type) V1.0

① select the right COM port (“my computer——properties——device manager——Port”) and check the COM port from the Port, the name of several different kinds of 485 transmitter drive

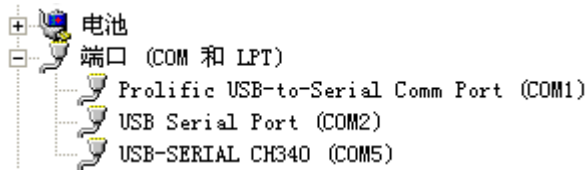

② connect with only one device and be powered, and click “test the baud rate” of the software to test the device baud rate and address, the default baud rate is 4800bit/s and default address is 0x01

③change the address and baud rate based on the application requirement, and meanwhile the current situation of the device function can be checked

④if the test is not success, please check the device wiring and 485 drive installation situation again

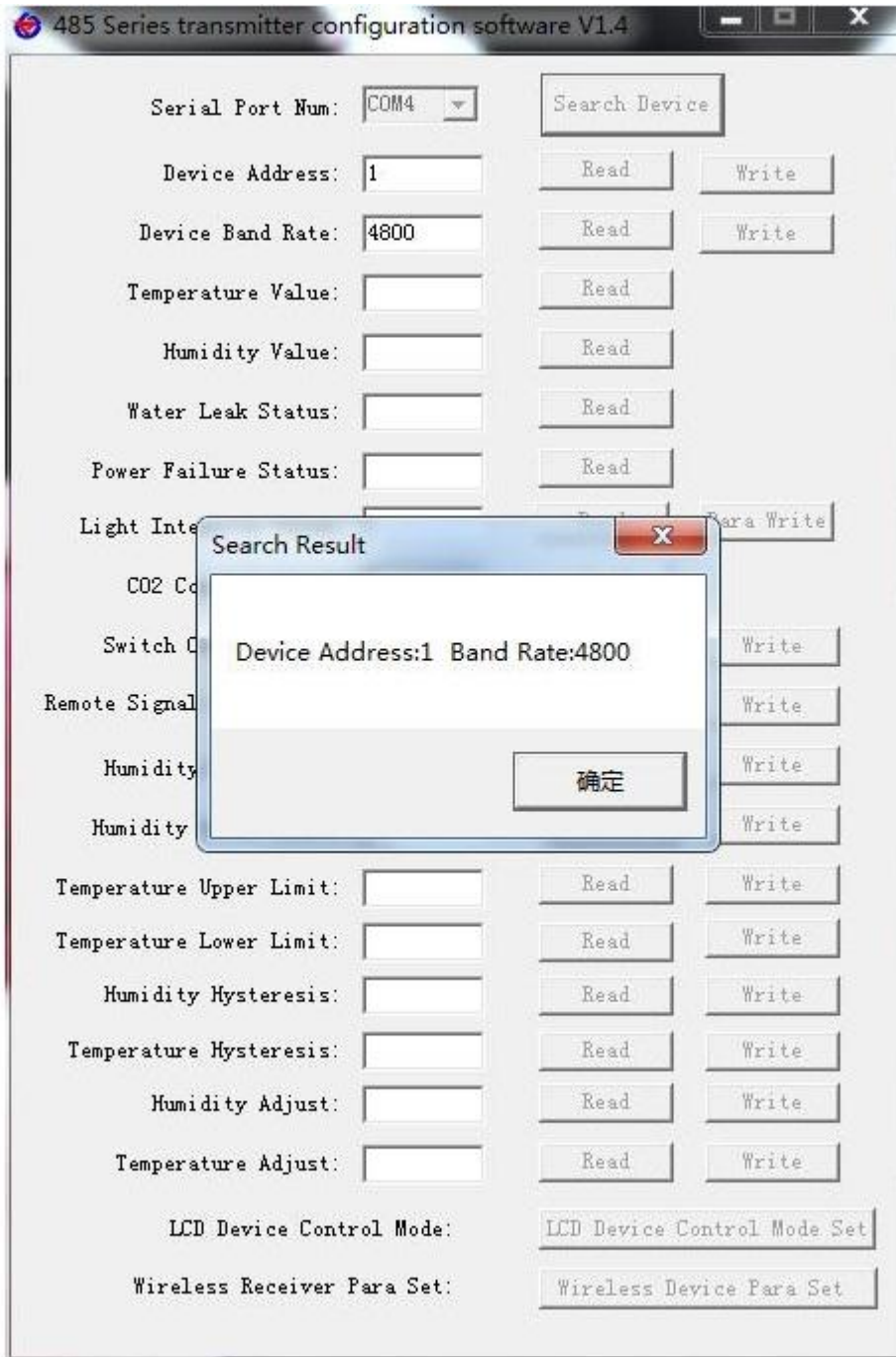





## 4. Communication Protocol

### 4.1 The basic parameters of Communications

Ed code	8-bit binary
Data bits	8
Parity bit	no
Stop bit	1
Error checking	CRC (cyclic redundancy code)
Baud rate	2400bit / s, 4800bit / s, 9600 bit / s can be set, the default setting is 48 00bit / s

### 4.2 Frame format definition data

Using Modbus - RTU communication protocol, in the following format:

Initial structure  $\geq$  4 byte time

address code = 1 byte

function code = 1 byte

Data area = N bytes

Error checking = 16-bit CRC

End structure  $\geq$  4 byte time

Address code: for the address of the transmitter, the communication network is the only (factory default 0x01).

Function Code: The host command functions such directions, the transmitter has used only the function code 0x03 (read data register).

Data area: data area is the specific communication data, note data of 16bits endian!

CRC code: two-byte checksum.

Host query frame structure:

address code	function code	Register start address	Register length	Check code low	Check code high
1 byte	1 byte	2 bytes	2 bytes	1 byte	1 byte

Slave Answer Frame Structure:

address code	function code	Valid bytes	Data area	Second data area	The first data region N	Check code
1 byte	1 byte	1 byte	2 bytes	2 bytes	2 bytes	2 bytes

### 4.3 Register Address



Register address	PLC or configuration address	content	operating
0000 H	40001	Air pressure Upload data 10 times real data	Read only
0001 H	40002	temperature Upload data 10 times real data	Read only

## 4.4 protocol examples and explanation

**Example: Read the atmospheric pressure and the temperature of the device address 0x01**

Inquiry frame:

address code	function code	Start address	Data length	Check code low	Check code high
0x 01	0x0 3	0x00 0x00	0x00 0x0 2	0x C4	0x 0B

Answer frame: (E.g., the pressure reading is 1 5. 1 Kpa, a temperature of -10.1 deg.] C)

address code	function code	Returns the number of valid bytes	Air pressure	Temperature value	Check code low	Check code high
0x 01	0x0 3	0x0 4	0x0 0 0x9 7	0x FF 0x 9B	0x 4B	0x 84

Temperature calculation:

When the temperature is below 0 °C When the temperature data is uploaded in the form of complement.

Temperature: FF9B H (hexadecimal) = --101 => Temperature = -10.1 °C

Pressure is calculated:

Pressure: 97 H (hexadecimal) = 151 => Pressure = 1 5. 1 Kpa

## 5. Common Problems and Solutions

### 5.1 device can not connect to a PLC or PC

possible reason:

- 1) computer has multiple COM ports, port selection is not correct.
- 2) device address error, or there is a duplicate device address (factory default all 1).
- 3) The baud rate, parity, data bits, stop bits error.



- 4) The master polling interval and response wait time is too short, it is required more than 200ms provided.
- 5) 485 has turned off, or A, B line reversed.
- 6) the number of devices or the wiring too long, to be near the power supply, plus booster 485, while increasing 120  $\Omega$  termination resistor.
- 7) USB drive switch 485 is not installed or damaged.
- 8) equipment damage.

## 6. Contact

Shandong RenKe Control Technology Co.,Ltd.  
Post code: 250101  
Tel: +86-531-58720832  
Fax: +86-531-67805165  
Website address: [www.temperaturehumiditysensor.com](http://www.temperaturehumiditysensor.com)

## 7. Document History

V1.0 documents created.

## 8. Size housing

**Overall dimensions: 100 × 85 × 26 mm**