



# QTS-1710 SERIES Combustible Gas Transmitter

The QTS-1710 Series utilizes a standard pellistor bead technology for the measurement of combustible gases. The sensor is resistant to poisoning substances such as Silicones, Sulphur and Chlorinated compounds. The Sensor is mounted to an explosion-proof housing while the transmitter provides a 3-wire, linear 4 to 20 mA output signal that is proportional to the LEL (Lower Explosive Limit) of the calibrated combustible gas. Test jacks are provided to monitor the transmitter signal without having to interrupt the output signal and Zero and Span adjustments allow for field calibration. Calibration and bump testing should be completed every three months in all combustible or explosive atmospheres. Calibration gases and 0.5

liter/minute gas regulators are not available through ACI. These should be purchased through your local gas supply company or companies such as Portagas® (Praxair®, Inc.) or Mesa Specialty Gases®. See the Q8 Combustible and Toxic Gas transmitter product data sheet for all applications that require a local display, remote sensor and a wider range of gases and output options. Refer to all applicable Federal, State, Provincial and Local Health and Safety laws and regulations before using these products.

**Applications:** Mechanical Rooms, Warehouses, Refrigeration Plants, Industrial Plants, Process Monitoring, Leak Detection, Parking Garages, Auto/Truck Maintenance Facilities

**The QTS-1710 Series Gas Transmitters are covered by ACI's Two (2) Year Limited Warranty. The warranty can be found in the front of ACI's Sensors & Transmitters catalog, as well as on ACI's website, [www.workaci.com](http://www.workaci.com).**

## PRODUCT SPECIFICATIONS

<b>Supply Voltage   Protection:</b>	12 to 30 VDC   0.5A Socketed Pico Fuse
<b>Supply Current   Power Consumption:</b>	125 mA maximum (80 mA, typical)   3.75 Watts maximum
<b>Maximum Load (@ 24 VDC):</b>	700 Ohms (500 Ohms @ 20 VDC and 200 Ohms @ 12 VDC)
<b>Output Signal:</b>	4-20 mA (3-Wire; Power, Gnd/Com, Signal)
<b>Factory Set Range:</b>	See Gas Sensor Selection & Specification Table on back of data sheet
<b>Accuracy   Repeatability:</b>	+/- 1% LEL Methane   +/- 1% LEL Methane
<b>Zero Drift:</b>	< 2% of Range / Month at 68°F (20°C)
<b>Response Time (T90):</b>	< 30 Seconds, typical (< 10 seconds for 50% Full Scale Step Change)
<b>Sensor Warm Up Time</b>	24 Hours (Allow 24 hours before calibrating sensor after initial installation)
<b>Sensor Type:</b>	Dual Element Poison Resistant Catalytic Pellistor Bead
<b>Sensor Gas Types:</b>	Hydrocarbon Combustible Gases
<b>Sensor Life Expectancy:</b>	3 to 5 years, typical
<b>Unit Shelf Life:</b>	6 Months from date of purchase (Must be installed and operational)
<b>Replacement Sensor:</b>	Contact ACI
<b>Recommended Maintenance:</b>	Accuracy & Bump test every 3 months or as required by Code (Replace sensor as needed)
<b>Enclosure Specifications (Type, Material Type, Flammability, NEMA/IP Rating, Explosion Proof):</b>	Industrial Connection Head; Cast Aluminum Epoxy Coated; NEMA 4X (IP66) Weatherproof Rating Type 7 & 9 Explosion Proof Class 1 Div. 1, Groups B, C, D also 316 SS Sensor Housing Group A Rated; CSA, FM (Factory Mutual), EX (Explosion Proof), UL listed
<b>Operating Temperature:</b>	-40 to 122°F (-40 to 50°C)
<b>Operating Humidity:</b>	0 to 99% RH, non-condensing
<b>Operating Atmospheric Pressure <sup>1</sup>:</b>	14.696 psi (1.0132 bar) +/- 10%
<b>Recommended Storage Temperature/Humidity:</b>	32 to 68°F (0 to 20°C)   15 to 90% RH, Non-Condensing
<b>Wiring Connections   Wire Size:</b>	Screw Terminal Blocks   16 to 24 AWG (0.51 to 1.30 mm) Shielded Twisted Pair
<b>Terminal Block Torque Rating:</b>	0.37 ft-lb (0.502 Nm) Nominal
<b>Coverage Area   Mounting Height:</b>	See Gas Sensor Selection & Specification Table on back of data sheet
<b>Approvals:</b>	RoHS, CSA-4828-02 inspected to C22.2 No. 30 and C22.2 No. 142 (CSA File #: 088890 0 000)
<b>Product Weight:</b>	5.00 lbs (2.27 kg)
<b>Product Dimensions (L x W x H):</b>	<b>Wall Mount Version:</b> 10.70" (271.78 mm) x 5.71" (145.04 mm) x 4.25" (107.95 mm) <b>Duct Mount Version:</b> 7.50" (190.50 mm) x 5.71" (145.04 mm) x 7.50" (190.50 mm)

**Note:** When installed @ > 3000' above sea level, the gas transmitters must be verified for accuracy & re-calibrated as needed after installation





**DIMENSIONAL DRAWING**

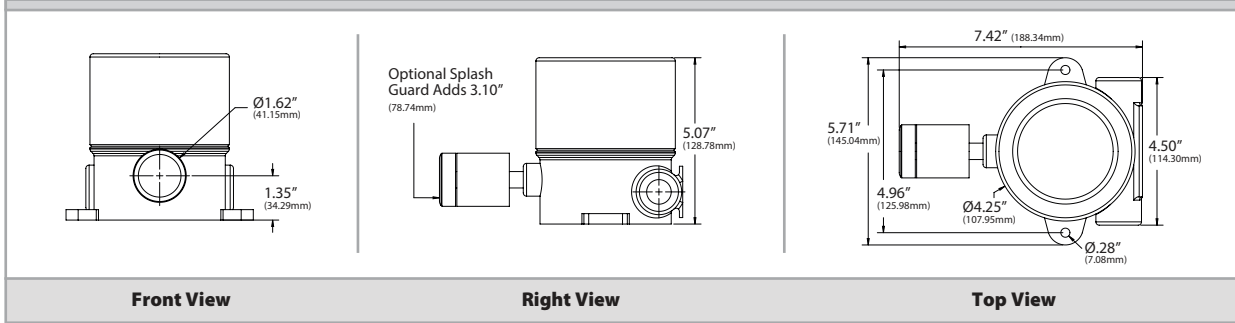

**SENSOR SELECTION AND SPECIFICATION**

**COVERAGE AREA**

Gas Type	Symbol	100% LEL <sup>1</sup> In % By Volume	Measurement Range	Square Footage	Radius	Mounting Height
Acetylene	C2H2	2.5 %	0 to 100% LEL	5000 ft <sup>2</sup> (464.5 m <sup>2</sup> )	40 ft (12.2 m)	Mid **
Benzene	C6H6	1.2 %	0 to 100% LEL	5000 ft <sup>2</sup> (464.5 m <sup>2</sup> )	40 ft (12.2 m)	Low **
Cyclohexane	C6H12	1.3 %	0 to 100% LEL	5000 ft <sup>2</sup> (464.5 m <sup>2</sup> )	40 ft (12.2 m)	Low **
Ethane	C2H6	3.0 %	0 to 100% LEL	5000 ft <sup>2</sup> (464.5 m <sup>2</sup> )	40 ft (12.2 m)	Low **
Ethanol	C2H6O	3.3 %	0 to 100% LEL	5000 ft <sup>2</sup> (464.5 m <sup>2</sup> )	40 ft (12.2 m)	Low **
Gasoline	---	1.3 %	0 to 100% LEL	5000 ft <sup>2</sup> (464.5 m <sup>2</sup> )	40 ft (12.2 m)	Low **
Hexane	C6H14	1.1 %	0 to 100% LEL	5000 ft <sup>2</sup> (464.5 m <sup>2</sup> )	40 ft (12.2 m)	Low **
Hydrogen	H2	4.0 %	0 to 100% LEL	7500 ft <sup>2</sup> (696.7 m <sup>2</sup> )	49 ft (14.9 m)	High **
Iso-Octane	C8H18	0.79 %	0 to 100% LEL	5000 ft <sup>2</sup> (464.5 m <sup>2</sup> )	40 ft (12.2 m)	Low **
Iso-Propyl Alcohol	C3H8O	2.0 %	0 to 100% LEL	5000 ft <sup>2</sup> (464.5 m <sup>2</sup> )	40 ft (12.2 m)	Low **
n-Butane	C4H10	1.9 %	0 to 100% LEL	5000 ft <sup>2</sup> (464.5 m <sup>2</sup> )	40 ft (12.2 m)	Low **
n-Octane	C8H18	1.0 %	0 to 100% LEL	5000 ft <sup>2</sup> (464.5 m <sup>2</sup> )	40 ft (12.2 m)	Low **
n-Pentane	C5H12	1.5 %	0 to 100% LEL	5000 ft <sup>2</sup> (464.5 m <sup>2</sup> )	40 ft (12.2 m)	Low **
Methane	CH4	5.0 %	0 to 100% LEL	7500 ft <sup>2</sup> (696.7 m <sup>2</sup> )	49 ft (14.9 m)	High **
Nonane	C9H20	0.85 %	0 to 100% LEL	5000 ft <sup>2</sup> (464.5 m <sup>2</sup> )	40 ft (12.2 m)	Low **
n-Propyl Alcohol	C3H8O	2.2 %	0 to 100% LEL	5000 ft <sup>2</sup> (464.5 m <sup>2</sup> )	40 ft (12.2 m)	Low **
Propane	C3H8	2.1 %	0 to 100% LEL	7500 ft <sup>2</sup> (696.7 m <sup>2</sup> )	49 ft (14.9 m)	High **

**Note<sup>1</sup>:** Lower Explosive Limit (LEL) | **Note<sup>\*\*</sup>:** Low = 1.0' (0.31m) above floor | Mid = 4.0 to 6.0' (1.20 to 1.83m) above floor | High = 0.5' to 1.5' (0.15 to 0.46m) below ceiling

**CUSTOM ORDERING**

Model # Example: QTS 171 0 1 X S P 0 0 0 0

**MODEL #**

<b>A. Sensor Series</b> <i>No Selection Required</i>	QTS	<b>QTS</b>
<b>B. Gas Transmitter</b> <i>No Selection Required</i>	171 = Combustible Transmitter Series	<b>171</b>
<b>C. Configuration</b> <i>Select One (1)</i>	0 = Methane 2 = Ethane 4 = n-Butane 6 = n-Octane 8 = Gasoline 1 = Acetylene 3 = Propane 5 = n-Pentane 7 = Hydrogen 9 = Other (Please Advise)	
<b>D. Factory Supplied</b> <i>No Selection Required</i>	1 = Factory Provided	<b>1</b>
<b>E. Revision</b> <i>No Selection Required</i>	X = Default	<b>X</b>
<b>F. Enclosure</b> <i>No Selection Required</i>	S = Aluminum, Epoxy Coated Weatherproof Industrial NEMA 4X, 7, 9 Enclosure	<b>S</b>
<b>G. Sensor Guard</b> <i>Select One (1)</i>	0 = No Sensor Splash Guard   P = Sensor Splash Guard	
<b>H. Factory Supplied</b> <i>No Selection Required</i>	0 = Default	<b>0</b>
<b>I. Factory Supplied</b> <i>No Selection Required</i>	0 = Default	<b>0</b>
<b>J. Factory Supplied</b> <i>No Selection Required</i>	0 = Default	<b>0</b>
<b>K. Calibration/Options</b> <i>Select One (1)</i>	0 = Default*   X = Non-Standard Calibration (Specify)   S = Special Options (Contact ACI)*	

**Note\*:** All transmitters are calibrated using a correlation method with Methane Gas and detection constants as shown. Calibration with actual target gas is available upon special request

**ACCESSORIES ORDERING**

Model # Example: 79030-103 -OR- 126566

Model #	Item #	Description
79030-103	126566	QTS-1710 Combustible Calibration Adaptor

