

| CONTACT SIZE | MIN. INSUL O.D. | MAX. INSUL O.D. | TYPICAL WIRE RANGE | CURRENT RATING |
|--------------|------------------|------------------|--------------------|----------------|
| 16 | 2.54mm (.100 in) | 3.40mm (.134 in) | 14-20AWG | 13 AMPS |

| REVISIONS | | | | | |
|-----------|-----|-----------------------|-----------|-----|------|
| REV | ECO | DESCRIPTION | DATE | BY | APPR |
| A1 | - | RELEASE | 11APR2019 | JAH | - |
| A2 | - | CORRECTED CROSS TABLE | 10MAY2021 | JAH | - |

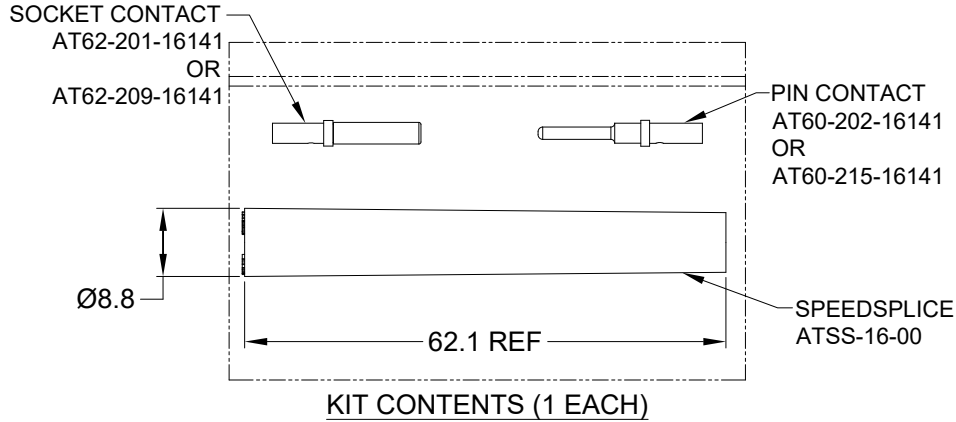

| PIN | DEUTSCH CROSS |
|----------------|----------------|
| ATSS-16-00 | JS-16-00 |
| AT60-202-16141 | 0460-202-16141 |
| AT60-215-16141 | 0460-215-16141 |
| AT62-201-16141 | 0462-201-16141 |
| AT62-209-16141 | 0462-209-16141 |

NOTES: UNLESS OTHERWISE SPECIFIED

- MATERIAL:
CONTACTS: COPPER ALLOY; NICKEL PLATED
INTEGRATED CONTACT RETENTION SYSTEM
SPEEDSPlice SEAL: SILICONE RUBBER
- CONTACT SIZE: 16
- SPECIFICATIONS:
3.1 CURRENT RATING: 13 AMPS
3.2 CONTACT MILLIVOLT DROP: 60 MILLIVOLT
DROP @ 13 AMP TEST CURRENT.
3.3 RoHS COMPLIANT
- RECOMMENDED WIRE RANGE: SEE CHART
- AVAILABLE HAND CRIMPER: CA-5D12
- ALL DIMENSIONS ARE FOR REFERENCE USE ONLY

| ASY P/N | RECOMMENDED WIRE RANGE | PIN CONTACT P/N | SOCKET CONTACT P/N |
|---------------|------------------------|-----------------|--------------------|
| ATSS-16-KIT01 | 16-20 AWG | AT60-202-16141 | AT62-201-16141 |
| ATSS-16-KIT02 | 14 AWG | AT60-215-16141 | AT62-209-16141 |

| QUANTITY | PART NUMBER | DESCRIPTION | ITEM |
|--|-------------|---|---------------------|
| MATERIALS LIST | | | |
| UNLESS OTHERWISE SPECIFIED 1) All dimensions are in metric(mm). 2) Tolerances are as follows: 1 PL DEC ±0.30 2 PL DEC ±0.15 3 PL DEC ±0.08 3) Note reference = | | SIGNATURES DATE DRAWN: J.HEAD 11APR2019 CHECKED: ENGINEER: APPROVAL: CUSTOMER: | |
| MATERIAL SPECIFICATIONS: | | Amphenol Sine Systems - www.amphenol-sine.com 44724 Morley Drive Clinton Township, MI 48036 | |
| PROCESS SPECIFICATIONS: | | | |
| NEXT ASSY: | | KIT, SPEEDSPlice & SIZE 16 SOLID CONTACTS. 16-20 AWG | |
| THIS DRAWING IS SUPPLIED FOR INFORMATION ONLY. DESIGN FEATURES, SPECIFICATIONS AND PERFORMANCE DATA SHOWN HEREON ARE THE PROPERTY OF THE AMPHENOL CORPORATION. NO RIGHTS OF REPRODUCTION ARE IMPLIED. ALL DIMENSIONS ARE SUBJECT TO NORMAL MANUFACTURING VARIATIONS. | | SIZE: A C- | REVISION: A2 |
| | | SCALE: NONE | SHEET 1 OF 1 |