

RECOMMENDED P.W.B. PATTERN LAYOUT
HATCHING AREA : PATTERN AND SOLDER PROHIBITED AREA

RECOMMENDED STENCIL MASK LAYOUT
RECOMMENDED STENCIL THICKNESS : T=0.08MM

- NOTE
- MATERIALS
HOUSING : LCP UL94-V0 (COLOR BLACK)
SIGNAL CONTACT : COPPER ALLOY
FIXING TAB : COPPER ALLOY
 - PLATING
SIGNAL CONTACT : Au FLASH OVER Ni UNDER PLATING (Ni BARRIER, LUBRICANT)
FIXING TAB : Au FLASH OVER Ni UNDER PLATING (ONLY CONTACT AND TAIL AREA)
 - MATE WITH: 103R***BB10*
 - CO-PLANARITY FOR SIGNAL CONTACT TERMINALS AND FIXING TAB MUST BE 0.08mm MAX.
 - THIS PRODUCT MEETS RoHS AND SONY SS-00259.
 - THE HOUSING WILL WITHSTAND EXPOSURE TO 250°C PEAK TEMPERATURE FOR 10SECONDS IN A REFLOW SOLDERING OVEN.
 - THE DOCUMENT MAY BE CHANGED WITHOUT PRIOR NOTICE.
 - PART NUMBER: 103P***BB10*

PIN POS. _____ 0: MASS PRODUCTION PACKAGE SPEC (15000PCS/REEL)
9: SAMPLE PACKAGE SPEC (2000PCS/REEL)

REV.	ECR/ECN No.	DESCRIPTION	DRAWN/DATE	CHECKED/DATE	APPROVED/DATE
X3		ADD 12PIN AND 20PIN	Hanson 12/16/'20	Sam 12/16/'20	Sam 12/16/'20
X4		ADD 8, 40, 48, 60PIN	Hanson 01/05/'21	Sam 01/05/'21	Sam 01/05/'21

9. RECOMMENDED REFLOW TEMPERATURE PROFILE USING LEAD-FREE SOLDER PASTE.

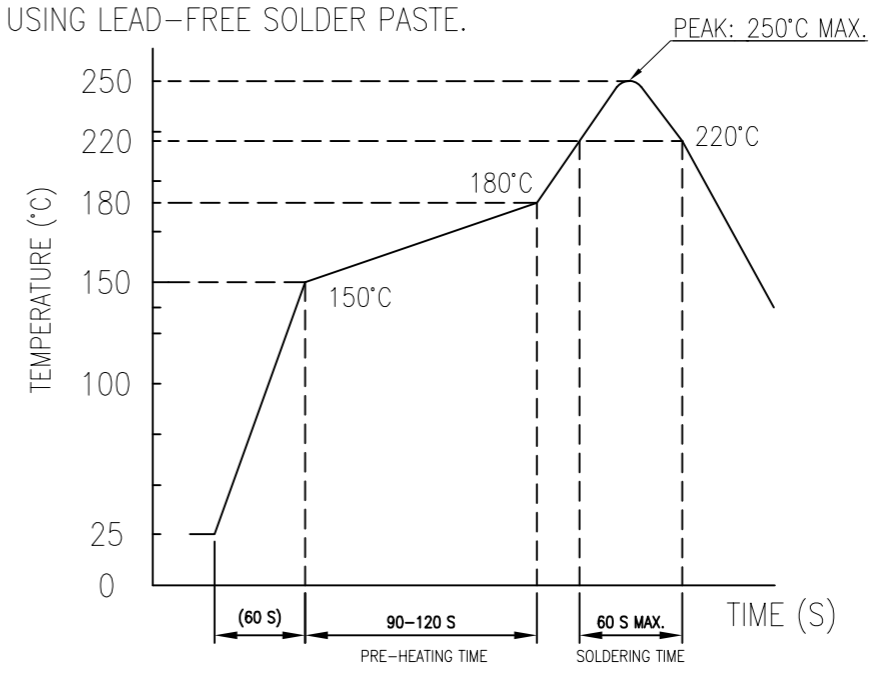

32	11.33	12.33	10.15	103P060BB10*	60 pin
24	9.58	10.58	8.40	103P050BB10*	50 pin
24	9.23	10.23	8.05	103P048BB10*	48 pin
24	7.83	8.83	6.65	103P040BB10*	40 pin
24	6.78	7.78	5.60	103P034BB10*	34 pin
16	6.08	7.08	4.90	103P030BB10*	30 pin
16	5.03	6.03	3.85	103P024BB10*	24 pin
16	4.33	5.33	3.15	103P020BB10*	20 pin
16	3.63	4.63	2.45	103P016BB10*	16 pin
16	3.28	4.28	2.10	103P014BB10*	14 pin
16	2.93	3.93	1.75	103P012BB10*	12 pin
16	2.58	3.58	1.40	103P010BB10*	10 pin
16	2.23	3.23	1.05	103P008BB10*	8 pin
16	1.58	2.88	0.70	103P006BB10*	6 pin
16	1.23	2.53	0.35	103P004BB10*	4 pin
D	C	B	A	Part Number	Pos.

UNLESS OTHERWISE SPECIFIED TOLERANCES		ANGLE OF PROJECTION		Amphenol AORORA	
X.	±0.30	X. °	± 3'	Amphenol Aorora Technology (Huizhou) Co.,Ltd	
X.X	±0.25	X.X °	± 2'		
X.XX	±0.20	X.XX °	± 1'		
X.XXX	±0.15	X.XXX °	± 1'		
LINEAR DIMS		ANGLES DIMS		DOC TYP Customer Drw	
DWG NO.: A-S0589		DRAWN DATE Hanson 2020-02-05		TITLE: Customer Drawing For 0.35mm Pitch SH=0.6mm BTB Connector 103 Series Plug Assembly	
MATERIAL SEE NOTES		DESIGN DATE Sam 2020-02-05		SIZE PART NUMBER: A3 103P***BB10*	
FINISHED SEE NOTES		CHECKED DATE Sam 2020-02-05		REV. X4	
		APPROVED DATE Leo 2020-02-05		SCALE 10:1 UNIT: mm SHEET 1 OF 3	

2021.01.06
文件发行

This document is the property of and embodies CONFIDENTIAL and PROPRIETARY information of AOR. No part of the information shown on this document may be used in any way or disclosed to others without the written consent of AOR. © 2019 AOR



(ACCUMULATIVE PITCH: 40±0.2)

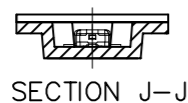
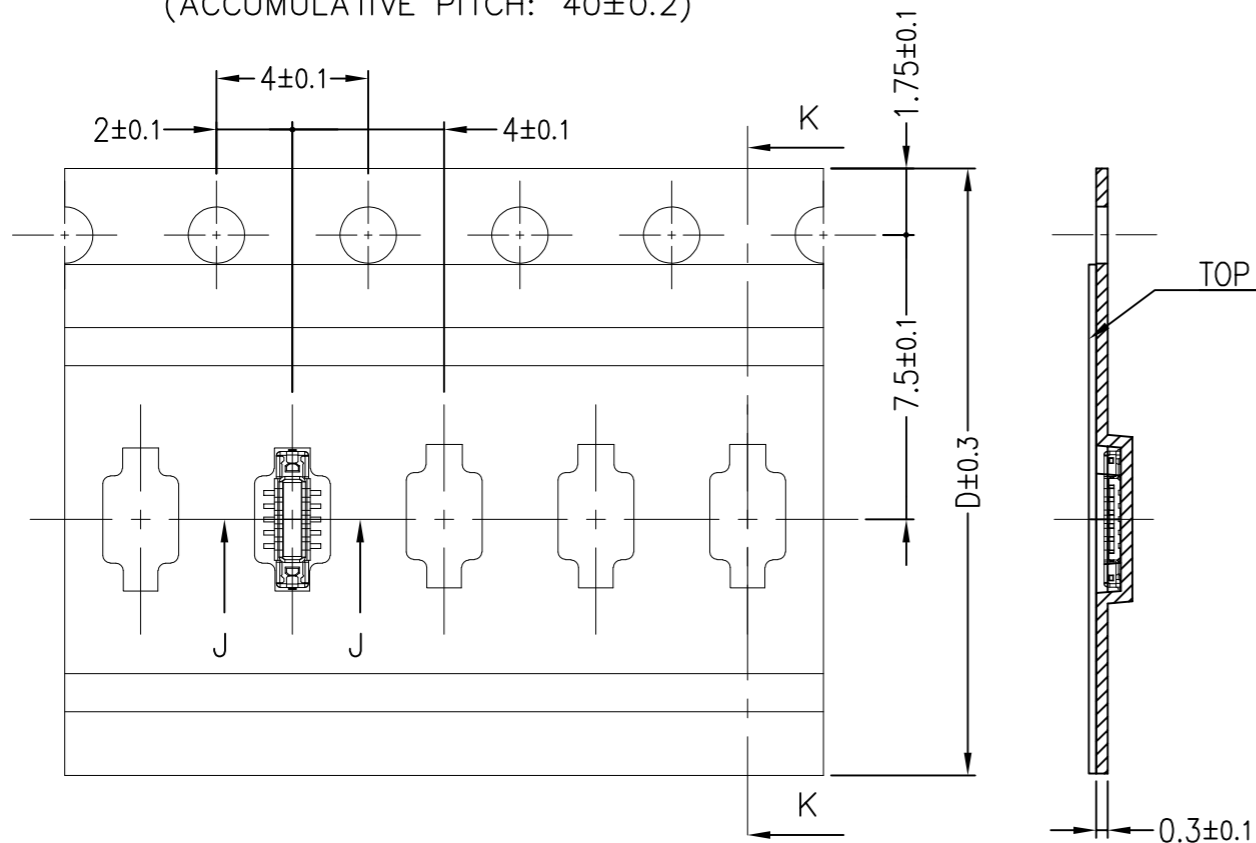

PULL OUT DIRECTION

SECTION K-K

103P***BB100: MASS PRODUCTION PACKAGE SPEC (15000PCS/REEL)

AIR CAP: 2PCS
380mm*380mm

VACUUM BAG
L550*W435*T0.10

DESICCANT

WATER PROOF 1PCS
L700*W600*T0.05

BIG CARTON: 1PCS
L385*W385*H130

TOTAL N LAYERS

TRANSPARENT TAPE

SIDE LABEL

103P***BB100: MASS PRODUCTION PACKAGE SPEC (15000PCS/REEL)

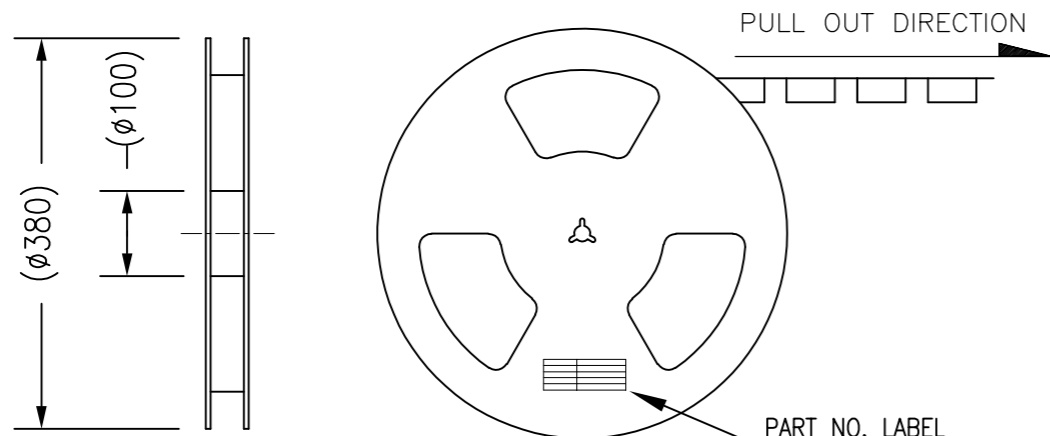
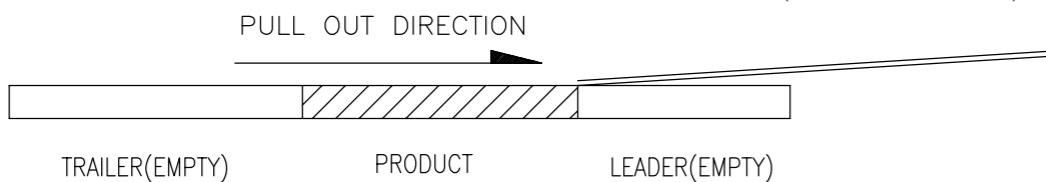

NOTES:

1. PEELING FORCE: 0.1N~0.7N (10~70gf);
PEELING ANGLE: 165°~180°;
PEELING SPEED: 300mm/minutes.
2. MATERIAL:
2.1 CARRIER TAPE: HIPS, T=0.3, CLEAR;
2.2 REEL: HIPS BLUE;
2.3 SHIM: PE, CLEAR;
3. PRIMARY PACKING: 15000PCS/REEL;
4. SECONDARY PACKING: "5" REELS/BIG CARTON;
("75000"=5*15000/BIG CARTON)

UNLESS OTHERWISE SPECIFIED TOLERANCES		ANGLE OF PROJECTION		 Amphenol Aorora Technology (Huizhou) Co.,Ltd
X.	±0.30	X. °	± 5'	
X.X	±0.25	X.X °	± 4'	
X.XX	±0.20	X.XX °	± 3'	
X.XXX	±0.15	X.XXX °	± 2'	
LINEAR DIMS		ANGLES DIMS		DOC TYP Emboss Package
DWG NO.: A-S0589		DRAWN DATE Hanson 2020-02-05		
MATERIAL SEE NOTES		DESIGN DATE Sam 2020-02-05		TITLE: Customer Drawing For 0.35mm Pitch SH=0.6mm BTB Connector 103 Series Plug Assembly
FINISHED SEE NOTES		CHECKED DATE Sam 2020-02-05		
		APPROVED DATE Leo 2020-02-05		SIZE PART NUMBER: A3 103P***BB10*
		SCALE 1:1		REV. X4
		UNIT : mm		SHEET 2 OF 3

2021.01.06
文件发行

This document is the property of and embodies CONFIDENTIAL and PROPRIETARY information of AOR. No part of the information shown on this document may be used in any way or disclosed to others without the written consent of AOR. © 2019 AOR



(ACCUMULATIVE PITCH: 40±0.2)

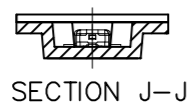
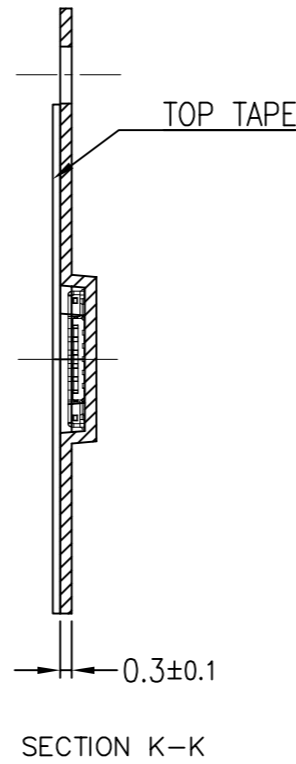
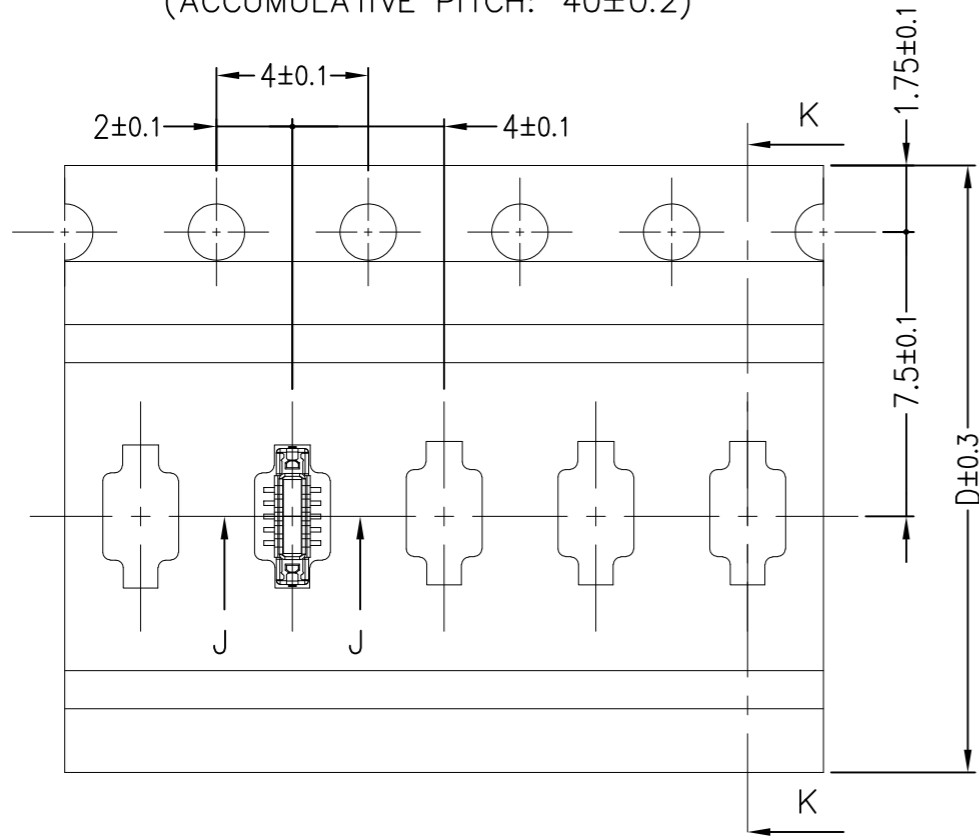

PULL OUT DIRECTION

103P***BB109: SAMPLE PACKAGE SPEC (2000PCS/REEL)

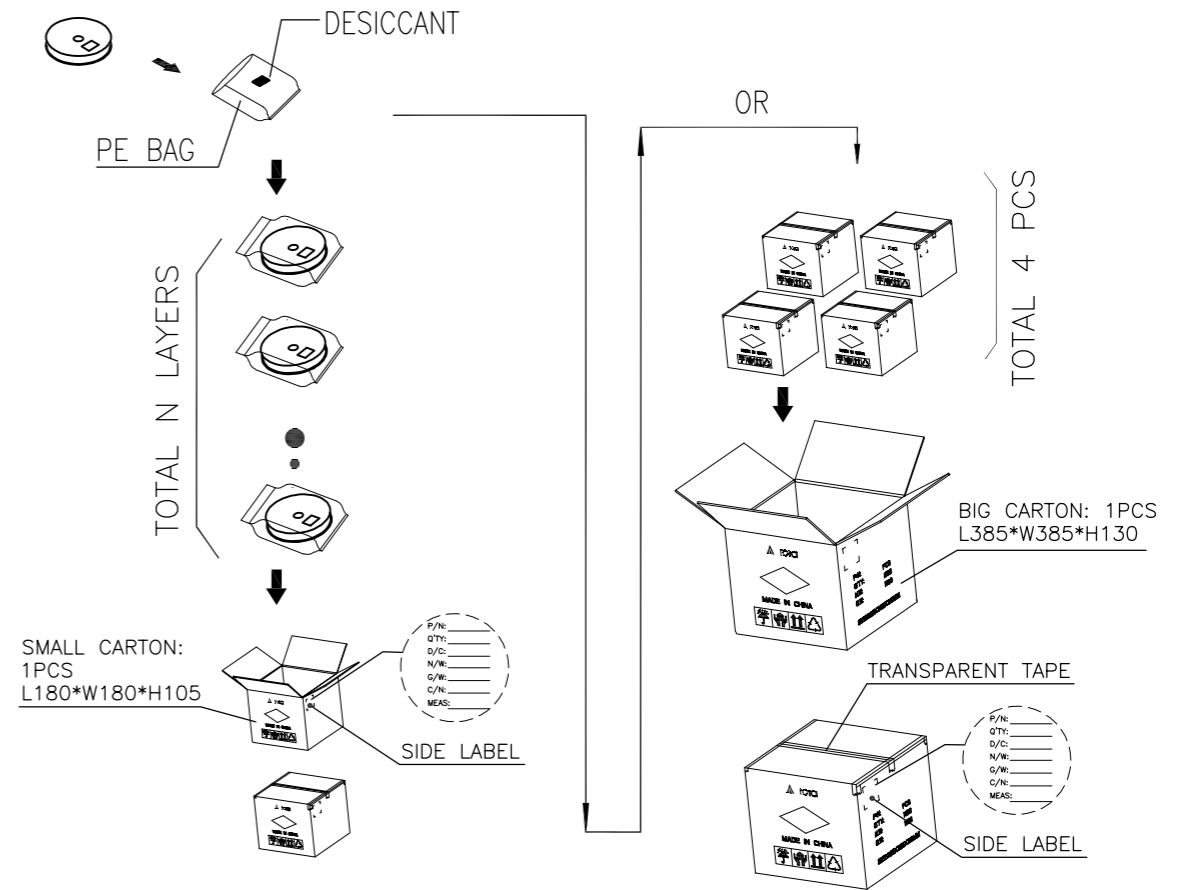

103P***BB109: SAMPLE PACKAGE SPEC (2000PCS/REEL)

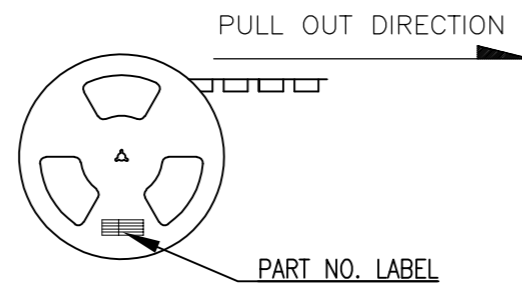
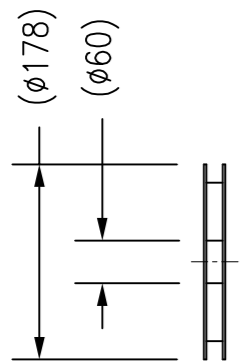
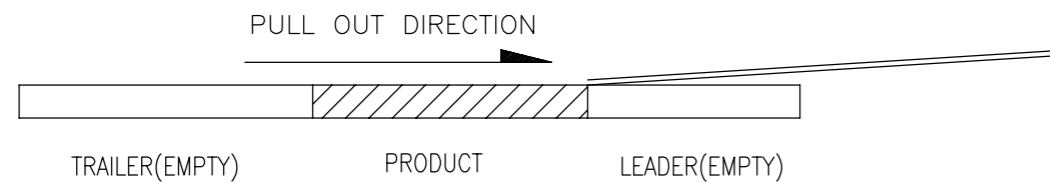

NOTES:

1. PEELING FORCE: 0.1N~0.7N (10~70gf);
PEELING ANGLE: 165°~180°;
PEELING SPEED: 300mm/minutes.
2. MATERIAL:
1.1 CARRIER TAPE: HIPS, T=0.3, CLEAR;
1.2 REEL: HIPS WHITE;
1.3 SHIM: PE, CLEAR;
3. PRIMARY PACKING: 2000PCS/REEL;
4. SECONDARY PACKING:
5 REELS/SMALL CARTON; 4 SMALL CARTON/1 BIG CARTON;
("40000"=1 BIG CARTON= 4 SMALL CARTON =4*5*2000 PCS)

UNLESS OTHERWISE SPECIFIED TOLERANCES		ANGLE OF PROJECTION		 Amphenol Aorora Technology (Huizhou) Co.,Ltd
X.	±0.30	X. °	± 5'	
X.X	±0.25	X.X °	± 4'	
X.XX	±0.20	X.XX °	± 3'	DOC TYP Emboss Package
X.XXX	±0.15	X.XXX °	± 2'	
LINEAR DIMS		ANGLES DIMS		DRAWN DATE Hanson 2020-02-05
DWG NO.: A-S0589		DESIGN DATE		
MATERIAL		CHECKED DATE		Sam 2020-02-05
FINISHED		APPROVED DATE		Leo 2020-02-05
TITLE:				Customer Drawing For 0.35mm Pitch SH=0.6mm BTB Connector 103 Series Plug Assembly
SIZE PART NUMBER:				
A3 103P***BB10*				REV. X4
SCALE 1:1		UNIT : mm		SHEET 3 OF 3

2021.01.06
文件发行

This document is the property of and embodies CONFIDENTIAL and PROPRIETARY information of AOR. No part of the information shown on this document may be used in any way or disclosed to others without the written consent of AOR. © 2019 AOR

Amphenol AORORA