

# IB IL 24 DO 16 ...

## Inline Terminal With 16 Digital Outputs

### AUTOMATIONWORX

Data Sheet  
5559\_en\_05

© PHOENIX CONTACT - 09/2007

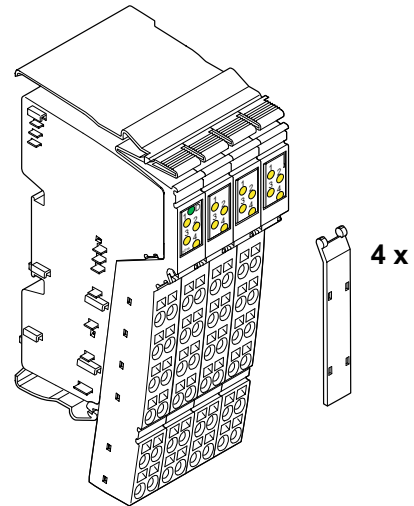

## Description

The terminal is designed for use within an Inline station. It is used to output digital signals.

### Features

- Connections for 16 digital actuators
- Connection of actuators in 2 and 3-wire technology
- Nominal current per output: 0.5 A
- Total current of the terminal: 8 A
- Short-circuit and overload protected outputs
- Diagnostic and status indicators
- **IB IL 24 DO 16, IB IL 24 DO 16-PAC and IB IL 24 DO 16-PAC/SN:**  
Approved for the use in potentially explosive areas (observe the notes on page 8)



This data sheet is only valid in association with the IL SYS INST UM E user manual or the Inline system manual for your bus system.



Please note that the numbering of the terminal points differs with regard to the different connector versions, Figure 2 on page 7.



Make sure you always use the latest documentation.  
It can be downloaded at [www.download.phoenixcontact.com](http://www.download.phoenixcontact.com).  
A conversion table is available on the Internet at [www.download.phoenixcontact.com/general/7000\\_en\\_00.pdf](http://www.download.phoenixcontact.com/general/7000_en_00.pdf).



This data sheet is valid for the products listed on the following page:

## Ordering Data

### Products

Description	Type	Order No.	Pcs./Pkt.
Inline terminal with 16 digital outputs; complete with accessories (connector and labeling fields); transmission speed of 500 kbps	IB IL 24 DO 16-PAC	2861292	1
Inline terminal with 16 digital outputs; complete with accessories (connector with individual numbering and labeling fields); transmission speed of 500 kbps	IB IL 24 DO 16-PAC/SN	2862961	1
Inline terminal with 16 digital outputs; without accessories; transmission speed of 500 kbps	IB IL 24 DO 16	2726272	1
Inline terminal with 16 digital outputs; complete with accessories (connector and labeling fields); transmission speed of 2 Mbps	IB IL 24 DO 16-2MBD-PAC	2862013	1
Inline terminal with 16 digital outputs; complete with accessories (connector with individual numbering and labeling fields); transmission speed of 2 Mbps	IB IL 24 DO 16-2MBD-PAC/SN	2878324	1
Inline terminal with 16 digital outputs; without accessories; transmission speed of 2 Mbps	IB IL 24 DO 16-2MBD	2855318	1



Four of the listed connectors or one connector set are needed for the complete fitting of the IB IL 24 DO 16 and IB IL 24 DO 16-2MBD terminals.

### Accessories

Description	Type	Order No.	Pcs./Pkt.
Connector, without color print, for digital 4-channel or 16-channel Inline terminals	IB IL SCN-12	2726340	10
Connector, with color print, for digital 4-channel or 16-channel Inline terminals	IB IL SCN-12-OCP	2727624	10
Connector set with 48 spring-cage connections (green, w/o color print)	IB IL DI/DO 16-PLSET	2860976	1
Connector set with 48 spring-cage connections (green, with color print)	IB IL DO 16-PLSET/OCP	2860992	1

### Documentation

Description	Type	Order No.	Pcs./Pkt.
"Automation Terminals of the Inline Product Range" user manual	IL SYS INST UM E	2698737	1
"Configuring and Installing the INTERBUS Inline Product Range" user manual	IB IL SYS PRO UM E	2743048	1
"INTERBUS Addressing" data sheet	DB GB IBS SYS ADDRESS	9000990	1
"Inline Terminals for Use in Zone 2 Potentially Explosive Areas" application note	AH EN IL EX ZONE 2	7217	1
"Addressing of 16-Channel Modules" application note	AH IB IL 24 DI/DO 16 ADDRESS	9014124	1

## Technical Data

### General Data

Housing dimensions (width x height x depth)	48.8 mm x 120 mm x 71.5 mm
Weight	130 g (without connector), 152 g (with connector)
Operating mode	Process data mode with 1 word
Connection method for actuators	2 and 3-wire technology
Ambient temperatures (operation)	-25°C to +55°C
Ambient temperature (storage/transport)	-25°C to +85°C
Permissible humidity (operation/storage/transport)	10% to 95% according to DIN EN 61131-2
Permissible air pressure (operation/storage/transport)	70 kPa to 106 kPa (up to 3000 m above sea level)
Degree of protection	IP20 according to IEC 60529
Class of protection	Class 3 according to EN 61131-2, IEC 61131-2
Connection data for Inline connector	
Connection type	Spring-cage terminals
Conductor cross-section	0.2 mm <sup>2</sup> to 1.5 mm <sup>2</sup> (solid or stranded), 24 - 16 AWG

### Interface

Local bus	Through data routing
-----------	----------------------

### Transmission Speed

IB IL 24 DO 16-PAC	500 kbps
IB IL 24 DO 16-PAC/SN	500 kbps
IB IL 24 DO 16	500 kbps
IB IL 24 DO 16-2MBD-PAC	2 Mbps
IB IL 24 DO 16-2MBD-PAC/SN	2 Mbps
IB IL 24 DO 16-2MBD	2 Mbps

### Supply of the Module Electronics and I/O Through Bus Coupler/Power Terminal

Connection method	Via potential routing
-------------------	-----------------------

### Power Consumption

	500 kbps	2 Mbps
Communications power	7.5 V DC	7.5 V DC
Current consumption at U <sub>L</sub>	90 mA, maximum	105 mA, maximum
Power consumption at U <sub>L</sub>	0.675 W, maximum	0.79 W, maximum
Segment supply voltage U <sub>S</sub>	24 V DC (nominal value)	24 V DC (nominal value)
Nominal current consumption at U <sub>S</sub>	8 A (16 x 0.5 A), maximum	8 A (16 x 0.5 A), maximum

### Digital Outputs

Number	16
Nominal output voltage U <sub>OUT</sub>	24 V DC
Differential voltage for I <sub>nom</sub>	≤ 1 V
Nominal current I <sub>nom</sub> per channel	0.5 A
Tolerance of the nominal current	+10%
Total current	8 A
Protection	Short circuit; overload



Always 4 channels are thermally coupled, i.e., an error case in one channel can affect the other channels.

Nominal load	
Ohmic	48 Ω / 12 W
Lamp	12 W
Inductive	12 VA (1.2 H, 50 Ω)

**Digital Outputs (Continued)**

Signal delay upon power up of:

Nominal ohmic load	500 $\mu$ s, typical
Nominal lamp load	100 ms, typical (with switching frequencies up to 8 Hz; above this frequency the lamp load responds like an ohmic load)
Nominal inductive load	100 ms (1.2 H, 50 $\Omega$ ), typical

Signal delay upon power down of:

Nominal ohmic load	1 ms, typical
Nominal lamp load	1 ms, typical
Nominal inductive load	50 ms (1.2 H, 50 $\Omega$ ), typical

Switching frequency with

Nominal ohmic load	300 Hz, maximum
--------------------	-----------------



This switching frequency is limited by the selected data rate, the number of bus devices, the bus structure, the software and the control or computer system used.

Nominal lamp load	8 Hz, maximum
-------------------	---------------



This switching frequency is limited by the selected data rate, the number of bus devices, the bus structure, the software and the control or computer system used.

Nominal inductive load	0.5 Hz (1.2 H, 50 $\Omega$ ), maximum
Overload response	Auto restart
Response time with ohmic overload (12 $\Omega$ )	3 s, approximately
Restart frequency with ohmic overload	400 Hz, approximately
Restart frequency with lamp overload	400 Hz, approximately
Response with inductive overload	Output may be damaged
Response time in the event of a short circuit	3 s, approximately
Reverse voltage protection against short pulses	Protected against reverse voltages
Resistance to permanently applied reverse voltages	Protected against reverse voltages, permissible current 2 A, maximum
Validity of output data after connecting the 24 V supply voltage (power up)	5 ms, typical
Response upon power down	The output follows the supply voltage without delay.
Limitation of the voltage induced on circuit interruption	-15 V $\leq$ U <sub>demag</sub> $\leq$ -45.8 V (U <sub>demag</sub> = demagnetization voltage)
One-time unsolicited energy	400 mJ, maximum
Protective circuit type	Integrated 45 V Zener diode in the output chip
Overcurrent circuit	0.7 A, minimum
Output current when switched off	300 $\mu$ A, maximum
Output voltage when switched off	2 V, maximum
Output current with ground connection interrupt	25 mA, maximum
Switching power with ground connection interrupt	100 mW at 1 k $\Omega$ load resistance, typical
Inrush current with lamp load	1.5 A for 20 ms, maximum

**Output Characteristic Curve When Switched On (Typical)**

Output Current (A)	Output Voltage Difference (V)
0	0
0.1	0.04
0.2	0.08
0.3	0.12
0.4	0.16
0.5	0.20

**Power Dissipation**

**500 kbps** **2 Mbps**

**Formulas to Calculate the Power Dissipation of the Electronics**

$$P_{EL} = 0.19 \text{ W} + \sum_{i=1}^n (0.10 \text{ W} + I_{Li}^2 \times 0.4 \ \Omega)$$

$$P_{EL} = 0.40 \text{ W} + \sum_{i=1}^n (0.10 \text{ W} + I_{Li}^2 \times 0.4 \ \Omega)$$

Where

$P_{EL}$  Total power dissipation in the terminal

$i$  Continuous index

$n$  Number of set outputs ( $n = 1$  to  $16$ )

$I_{Li}$  Load current of the output  $i$

**Power Dissipation of the Housing  $P_{HOu}$  (500 kbps and 2 Mbps)**

2.7 W, maximum (within the permissible operating temperature)

**Limitation of Simultaneity, Derating**

**(500 kbps and 2 Mbps)**

Ambient Temperature $T_A$	Maximum Load Current at 100% Simultaneity	Maximum Load Current at 75% Simultaneity
$-25^\circ\text{C} \leq T_A < +40^\circ\text{C}$	0.50	0.50
$+40^\circ\text{C} \leq T_A < +45^\circ\text{C}$	0.45	0.50
$+45^\circ\text{C} \leq T_A < +50^\circ\text{C}$	0.40	0.50
$+50^\circ\text{C} \leq T_A < +55^\circ\text{C}$	0.35	0.50

**Safety Equipment**

Overload/short circuit in segment circuit

Electronic; with four 4-channel drivers

Surge voltage

Protective elements of the power terminal

Protection up to 33 V DC

Polarity reversal of the supply voltage

Protective elements of the power terminal

The supply voltage must be protected. The power supply unit should be able to supply four times (400%) the nominal current of the fuse.

Reverse voltage

Integrated protection against reverse voltages

**Electrical Isolation/Isolation of the Voltage Areas**



To provide electrical isolation between the logic level and the I/O area it is necessary to supply the station bus coupler and the digital output terminal described here via the bus coupler or a power terminal from separate power supply units. Interconnection of the power supply units in the 24 V area is not permitted. (See also user manual.)

**Common Potentials**

The 24 V main voltage, 24 V segment voltage, and GND have the same potential. FE is a separate potential area.

**Separate Potentials in the System Consisting of Bus Coupler/Power Terminal and I/O Terminal**

**Test Distance**

**Test Voltage**

5 V supply incoming remote bus/7.5 V supply (bus logic)

500 V AC, 50 Hz, 1 min

5 V supply outgoing remote bus/7.5 V supply (bus logic)

500 V AC, 50 Hz, 1 min

7.5 V supply (bus logic)/24 V supply (I/O)

500 V AC, 50 Hz, 1 min

24 V supply (I/O) / functional earth ground

500 V AC, 50 Hz, 1 min

**Error Messages to the Higher-Level Control or Computer System**

Short circuit/overload of an output

Yes



An error message is generated when an output is short circuited and switched on. In addition, the diagnostic LED (D) flashes on the terminal at 2 Hz (medium) under these conditions.

Falling below or exceeding the operating voltage

No

**Approvals**

For the latest approvals, please visit [www.download.phoenixcontact.com](http://www.download.phoenixcontact.com) or [www.eshop.phoenixcontact.com](http://www.eshop.phoenixcontact.com).

## Local Diagnostic and Status Indicators and Terminal Point Assignment

### Local Diagnostic and Status Indicators

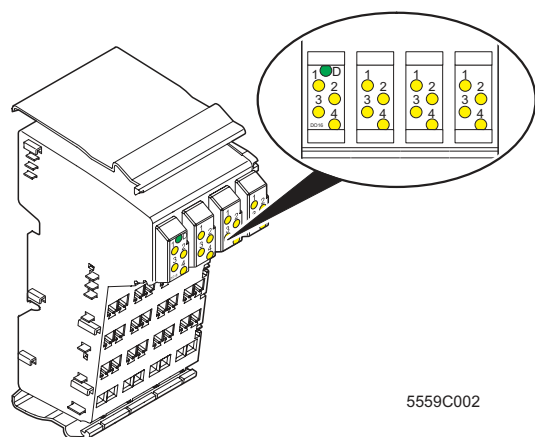

Figure 1 Diagnostic and status indicators

Des.	Color	Meaning
D	Green	Diagnostics
1, 2, 3, 4	Yellow	Status indicators of the outputs

### Function Identification

Pink

2 Mbps: white stripe in the vicinity of the D LED

### Terminal Point Assignment for Each Connector

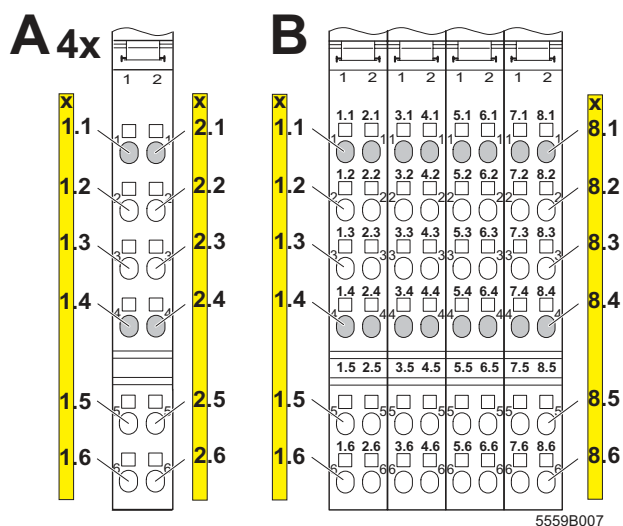



Figure 2 Terminal point numbering: individual connectors (A) and connector sets (B)

- A** – Using the IB IL 24 DO 16-PAC/SN or IB IL 24 DO 16-2MBD-PAC/SN with the supplied connectors
  - Using individual connectors (IB IL SCN-12 or IB IL SCN-12-OCF)
- B** – Using the IB IL 24 DO 16-PAC or IB IL 24 DO 16-2MBD-PAC with the original connector set
  - Using the IB IL DO 16-PLSET/OCF or IB IL DI/DO 16-PLSET connector sets

Terminal Point	Assignment
x.1	Signal output (OUT)
x.2	Ground contact (GND) for 2 and 3-wire termination
x.3	FE connection for 3-wire termination
x.4	Signal output (OUT)
x.5	Ground contact (GND) for 2 and 3-wire termination
x.6	FE connection for 3-wire termination

## Notes on Using the Terminal in Potentially Explosive Areas for the IB IL 24 DO 16, IB IL 24 DO 16-PAC, and IB IL 24 DO 16-PAC/SN Terminals

### Approval According to EC Directive 94/9 (ATEX)

 II 3G Ex nAC IIC T4 X

This Inline terminal conforms to the requirements of protection type "n" and can be installed in a zone 2 potentially explosive area. This Inline terminal is a category 3G item of electrical equipment.



**WARNING: Explosion hazard**  
Only Inline terminals that are approved for use in potentially explosive areas may be snapped next to this Inline terminal.

Before using an Inline terminal in a zone 2 potentially explosive area, check that the terminal has been approved for installation in this area.

For a list of terminals approved for zone 2 potentially explosive areas, please refer to the AH EN IL EX ZONE 2 application note.

Check the labeling on the Inline terminal and the packaging (see Figure 3).



Potential routing 4 A maximum for use in Ex areas

IBx IL xx xx x  
Order-No.: xxxxxxxx  
Module-ID: xx HW/FW xx/-  
PHOENIX CONTACT  
INTERBUS



5561C001

Figure 3 Typical labeling of terminals for use in potentially explosive areas



**WARNING: Explosion hazard**

Before startup, ensure that the following points and instructions are observed.

1. When working on the Inline terminal, always disconnect the supply voltage.
2. The Inline terminal must only be installed, started up, and maintained by qualified specialist personnel.
3. Install the Inline terminals in a control cabinet or metal housing. The minimum requirement for both items is IP54 protection according to EN 60529.
4. The Inline terminal must not be subject to mechanical strain or thermal loads, which exceed the limits specified in the product documentation.
5. The Inline terminal must not be repaired by the user. Repairs may only be carried out by the manufacturer. The Inline terminal is to be replaced by an approved terminal of the same type.
6. Only category 3G equipment may be connected to Inline terminals in zone 2.
7. Observe all applicable standards and national safety and accident prevention regulations for installing and operating equipment.

### Restrictions



**WARNING: Explosion hazard**

When using terminals in potentially explosive areas, observe the technical data and limit values specified in the corresponding documentation (user manual, data sheet, package slip).



**WARNING: Explosion hazard**  
Restrictions regarding the Inline system

The **maximum permissible current** flowing through the potential jumpers  $U_M$  and  $U_S$  (total current) is limited to **4 A** when using the Inline terminal in potentially explosive areas.





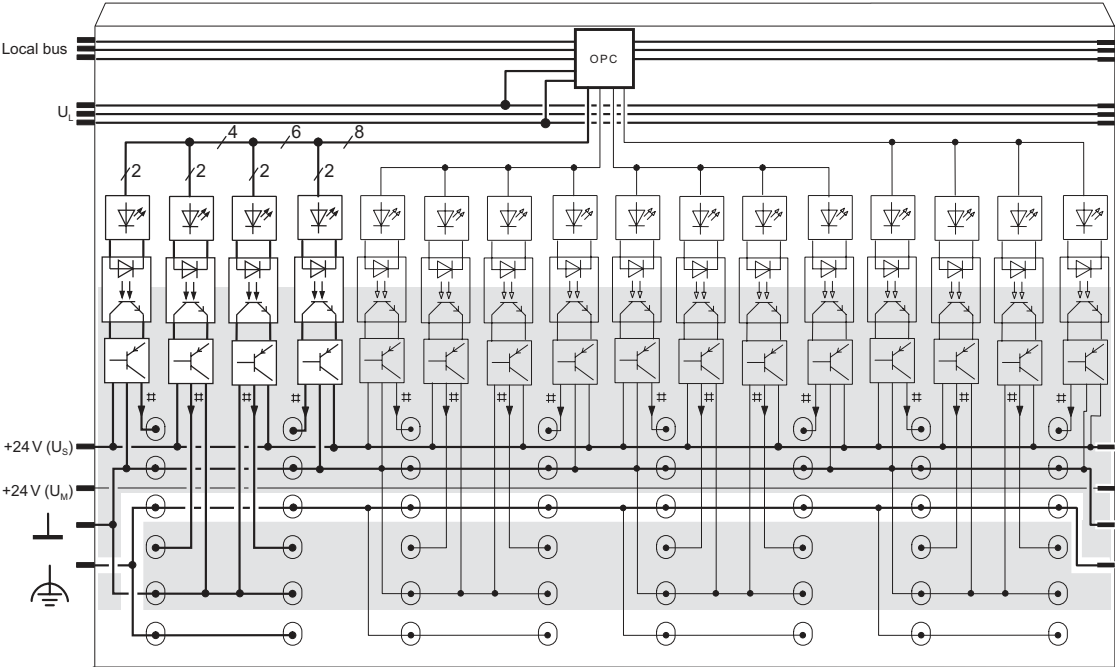



Internal Circuit Diagram



5559B003

Figure 4 Internal wiring of the terminal points

Key:

-  Protocol chip (bus logic including voltage conditioning)
-  LED
-  Optocoupler
-  Transistor
-  Digital output
-  Electrically isolated area

 Other symbols used are explained in the IL SYS INST UM E user manual or in the Inline system manual for your bus system.

## Connection Example



When connecting the actuators observe the assignment of the terminal points to the process data (see page 11).

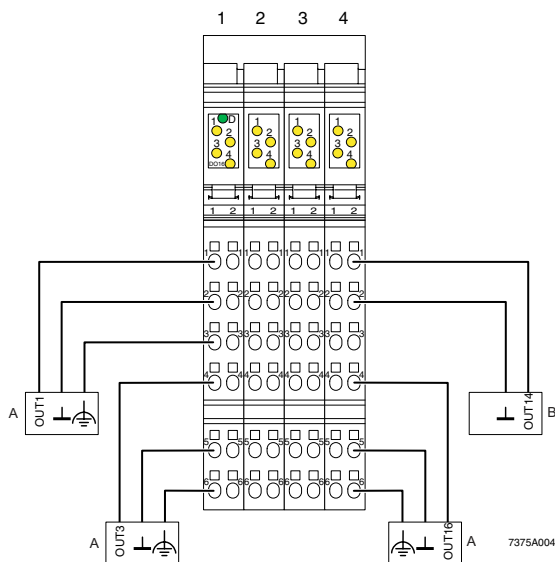

Figure 5 Typical actuator connection

- A 3-wire termination
- B 2-wire termination

The numbers above the module illustration identify the connector slots.

## Programming Data/Configuration Data

### Local Bus (INTERBUS)

ID code	BD <sub>hex</sub> (189 <sub>dec</sub> )
Length code	01 <sub>hex</sub>
Process data channel	16 bits
Input address area	0 words
Output address area	1 word
Parameter channel (PCP)	0 words
Register length (bus)	1 word

### Other Bus Systems



For the programming data/configuration data of other bus systems, please refer to the corresponding electronic device data sheet (e.g., GSD, EDS).

## Process Data



For the assignment of the illustrated (byte.bit) view to your **INTERBUS** control or computer system, please refer to the DB GB IBS SYS ADDRESS data sheet.

For the assignment of the illustrated (byte.bit) view to control systems of **other bus systems**, please refer to the AH IB IL 24 DI/DO 16 ADDRESS document.

### Assignment of the Terminal Points to the OUT Process Data



The following table applies to the IB IL 24 DO 16-PAC and IB IL 24 DO 16-2MBD-PAC terminals with the original connector set and when using the connector sets IB IL DI/DO 16-PLSET or IB IL DO 16-PLSET/OCF (see also Figure 2 on page 7, detail B).

(Byte.bit) view	Byte	Byte 0								Byte 1							
	Bit	7	6	5	4	3	2	1	0	7	6	5	4	3	2	1	0
Assignment	Slot	4				3				2				1			
	Terminal point (signal)	8.4	7.4	8.1	7.1	6.4	5.4	6.1	5.1	4.4	3.4	4.1	3.1	2.4	1.4	2.1	1.1
	Terminal point (GND)	8.5	7.5	8.2	7.2	6.5	5.5	6.2	5.2	4.5	3.5	4.2	3.2	2.5	1.5	2.2	1.2
	Terminal point (FE)	8.6	7.6	8.3	7.3	6.6	5.6	6.3	5.3	4.6	3.6	4.3	3.3	2.6	1.6	2.3	1.3
Status indicators	Slot	4				3				2				1			
	LED	4	3	2	1	4	3	2	1	4	3	2	1	4	3	2	1



The following table applies to the IB IL 24 DO 16-PAC/SN and IB IL 24 DO 16-2MBD-PAC/SN terminals with the original connector set and when using the IB IL SCN-12 or IB IL SCN-12-OPC connectors (see also Figure 2 on page 7, detail A).

(Byte.bit) view	Byte	Byte 0								Byte 1							
	Bit	7	6	5	4	3	2	1	0	7	6	5	4	3	2	1	0
Assignment	Slot	4				3				2				1			
	Terminal point (signal)	2.4	1.4	2.1	1.1	2.4	1.4	2.1	1.1	2.4	1.4	2.1	1.1	2.4	1.4	2.1	1.1
	Terminal point (GND)	2.5	1.5	2.2	1.2	2.5	1.5	2.2	1.2	2.5	1.5	2.2	1.2	2.5	1.5	2.2	1.2
	Terminal point (FE)	2.6	1.6	2.3	1.3	2.6	1.6	2.3	1.3	2.6	1.6	2.3	1.3	2.6	1.6	2.3	1.3
Status indicators	Slot	4				3				2				1			
	LED	4	3	2	1	4	3	2	1	4	3	2	1	4	3	2	1