

PART NAME

NEMA 4X ENCLOSURE

PART No.

PN-1344, PN-1344-C AND PN-1344-DG

REV. DATE

11-17-08

INDUSTRY STANDARDS:

- POLYCARBONATE (LIGHT GRAY AND CLEAR)
- UL94-HB FLAMMABILITY RATING (UL FILE #E41613)
- UV STABILIZED
- SERVICE TEMPERATURE RANGE: -40°C TO +120°C
- ABS (DARK GRAY)
- UL94-HB FLAMMABILITY RATING (UL FILE #E56070)
- SERVICE TEMPERATURE RANGE: -40°C TO +80°C

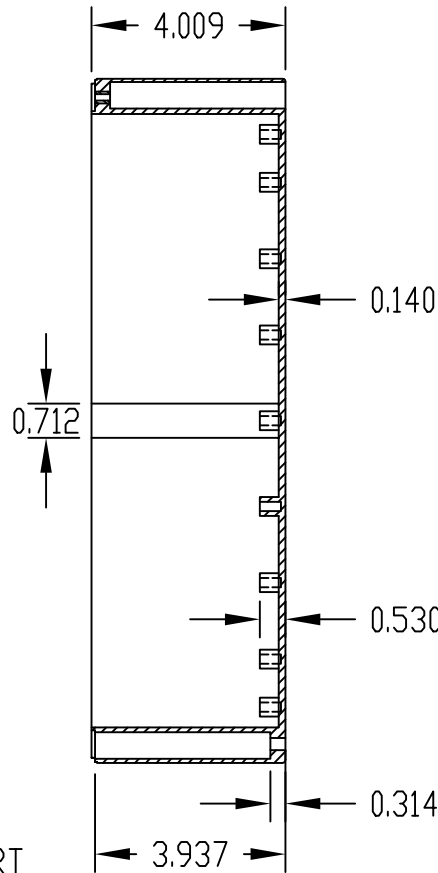
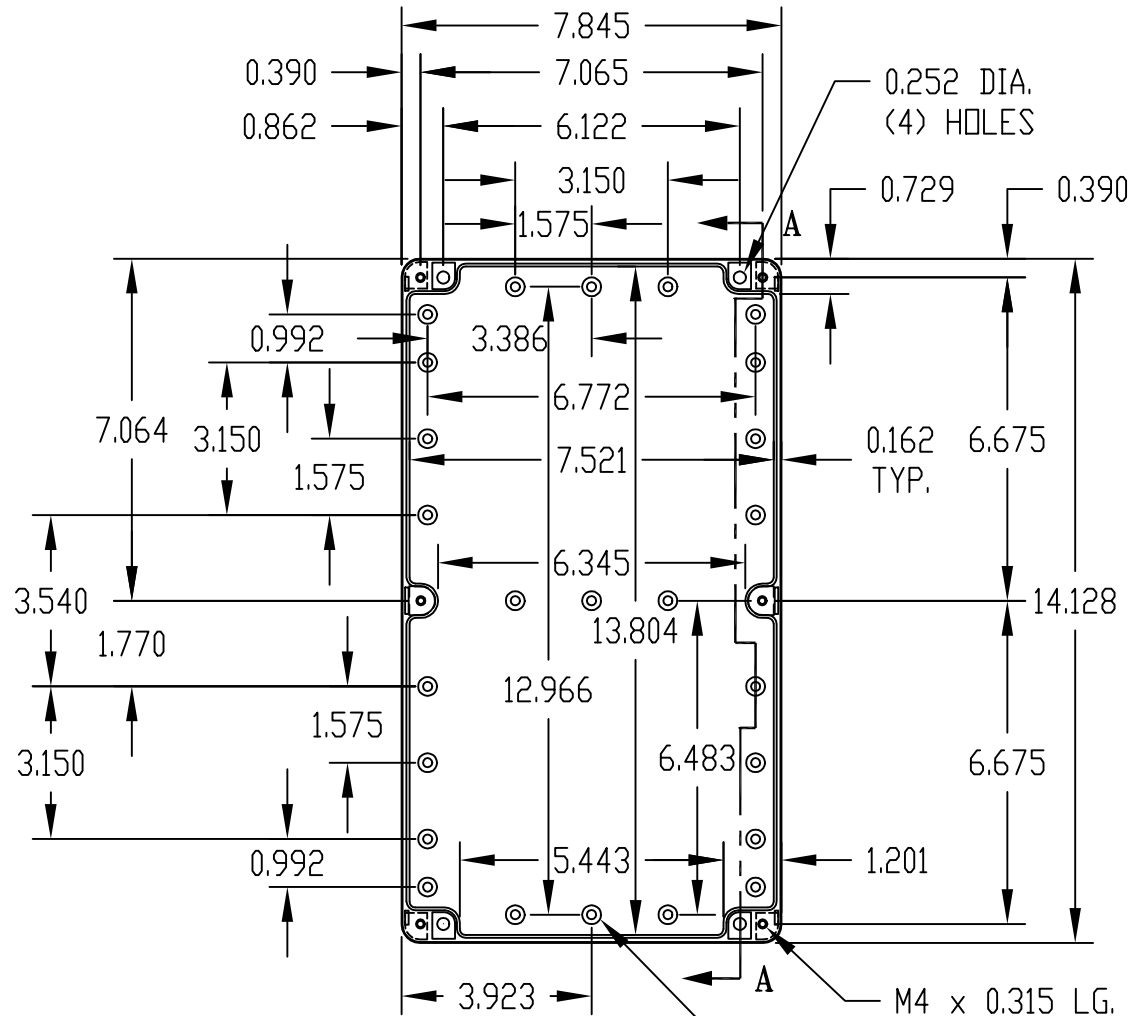

SECTION "A-A"

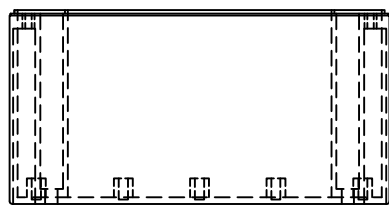

MOUNTING BOSSES USE EITHER
 M5 METRIC OR #12 STD. SHEET
 METAL SCREWS x 0.312 LG.
 (NOT SUPPLIED)

BODY

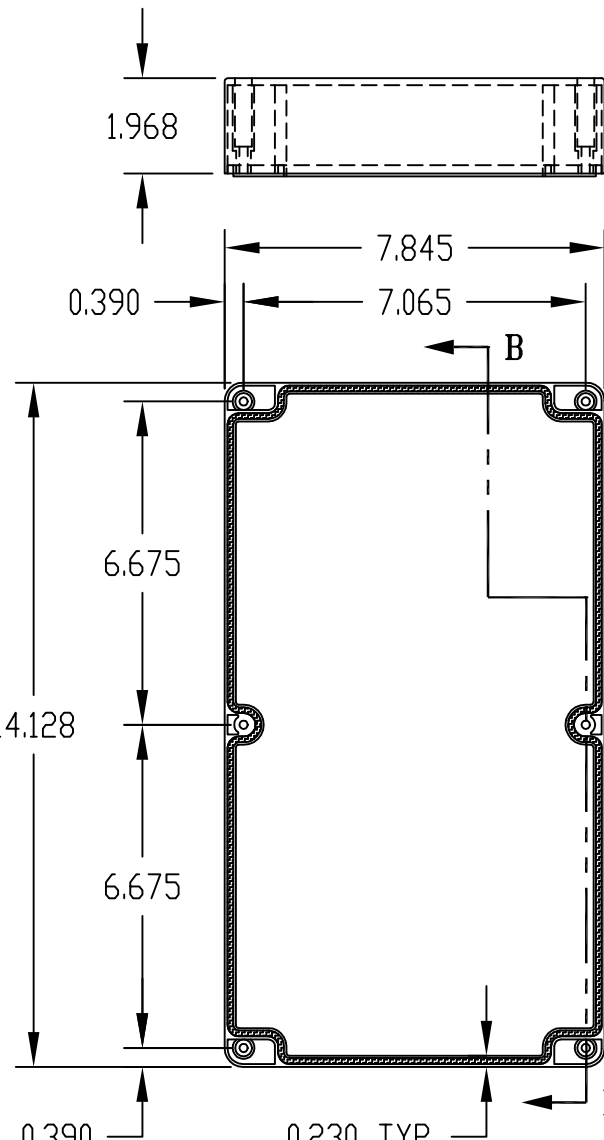

COVER

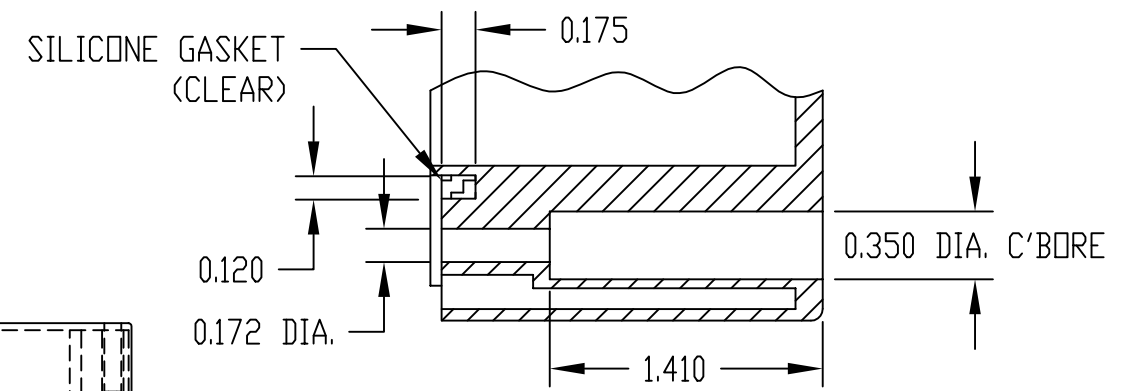

DETAIL "C"

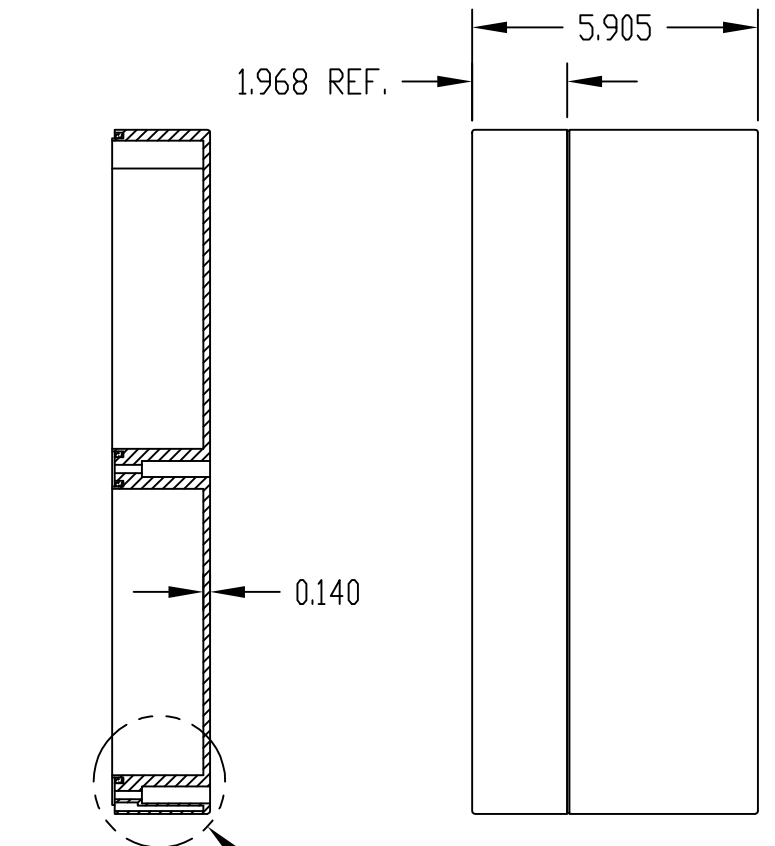

SECTION "B-B"

SEE DETAIL "C"

NOTE: ALL DIMENSIONS HAVE ±0.015 TOLERANCE UNLESS OTHERWISE SPECIFIED.

PART NUMBER	MATERIAL		FINISH		HARDWARE KIT
	BODY	COVER	BODY	COVER	
PN-1344	POLYCARBONATE		LIGHT GRAY		KIT CONTAINS (6) M4 x 25mm (1.000") LG. SCREWS FOR ASSEMBLY
PN-1344-C	POLYCARBONATE		LIGHT GRAY	CLEAR	
PN-1344-DG	HIGH-IMPACT ABS		DARK GRAY		