

THIS DRAWING IS UNPUBLISHED. RELEASED FOR PUBLICATION 2009
 © COPYRIGHT 2009 BY TYCO ELECTRONICS CORPORATION, ALL RIGHTS RESERVED.

LOC	DIST	REVISIONS					
		P	LTR	DESCRIPTION	DATE	DWN	APVD
IS	-	51		First issue	03MAY2010	MS	MG
		52		Sampling	12MAY2010	MS	MG
		53		Second sampling	11JUN2010	MS	MG
		A		Go to production	04NOV2010	MS	MG

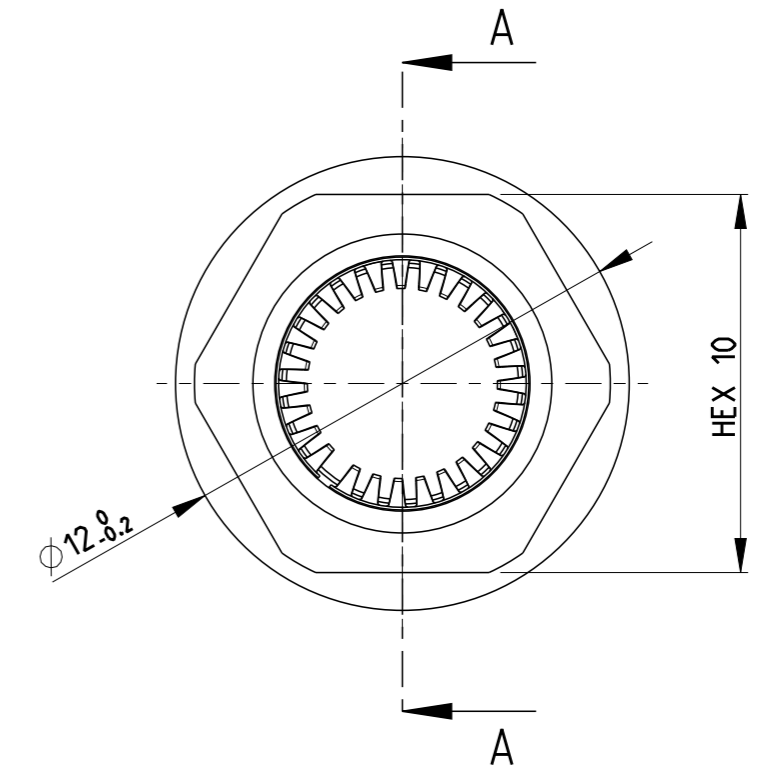

RECOMMENDED
PANEL CUT OUT

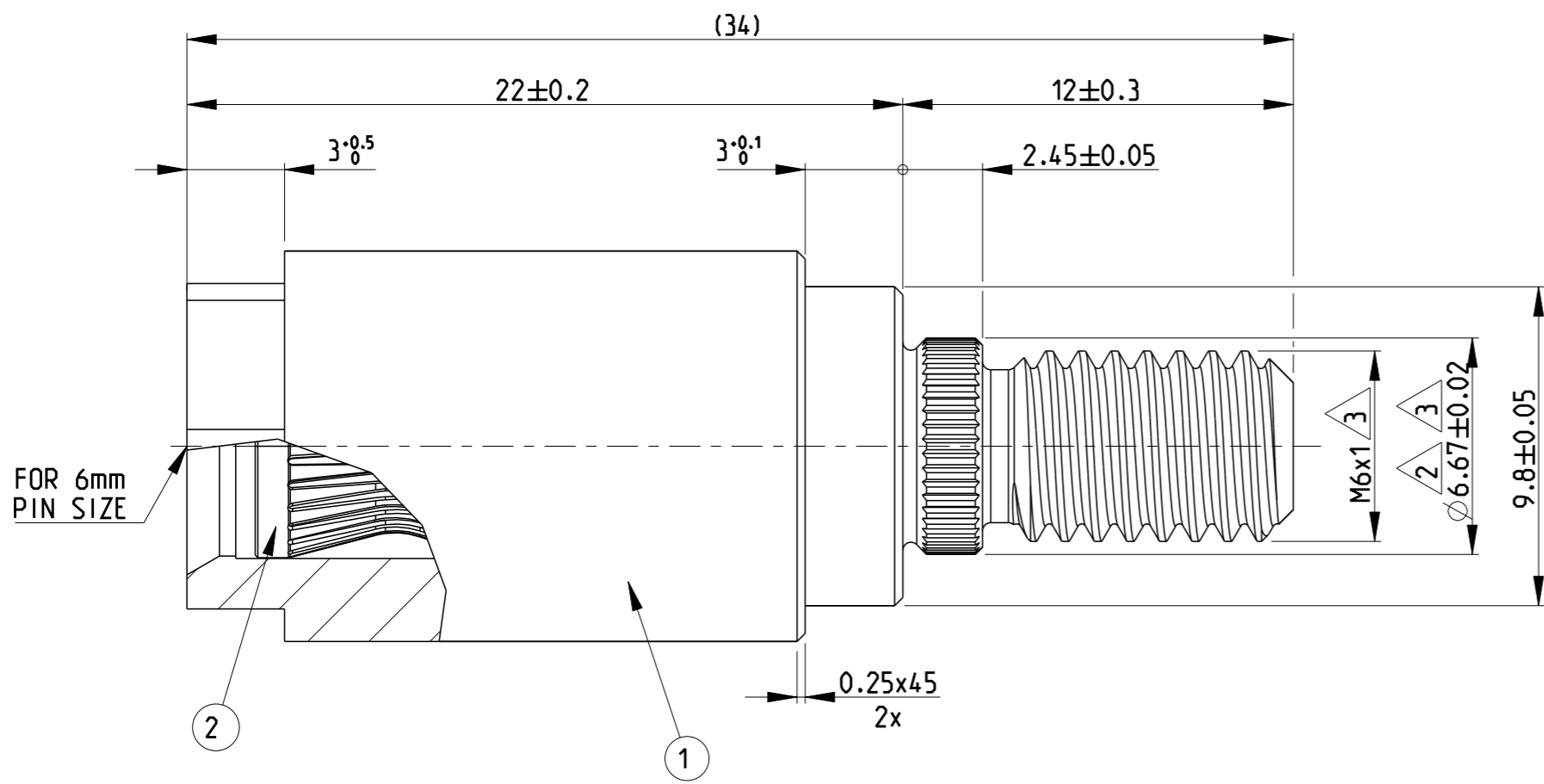
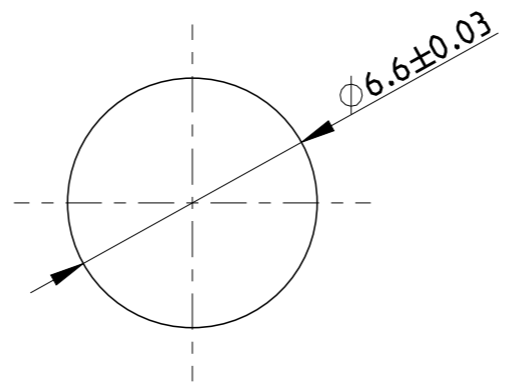

- 1 General tolerances acc.to ISO 2768-mH
- 2 Knurl according to DIN 82 RAA 0.5
- 3 Coupling torque 5N max.
- 4) Bulk-packagin

619445-1	2	CROWN	BeCu	min. 0.2 µm Au over Ni
	1	Outer Con.	Brass	min. 5 µm Ag
TE PN	Item	Description	Material	Plating

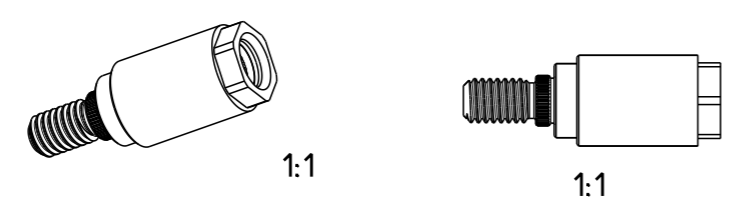

<small>THIS DRAWING IS A CONTROLLED DOCUMENT FOR TYCO ELECTRONICS CORPORATION IT IS SUBJECT TO CHANGE AND THE CONTROLLING ENGINEERING ORGANIZATION SHOULD BE CONTACTED FOR THE LATEST REVISION.</small>		DWN M.Scheggia 03MAY2010	Tyco Electronics Lugano - Switzerland	
DIMENSIONS: mm		CHK M.Grazioli 03MAY2010	NAME	
TOLERANCES UNLESS OTHERWISE SPECIFIED: 0 PLC ± 1 PLC ± 2 PLC ± 3 PLC ± 4 PLC ± ANGLES ±° FINISH -		APVD -	STRAIGHT SOCKET PIN SIZE 6mm 125 A	
MATERIAL -		PRODUCT SPEC -	SIZE A3	RESTRICTED TO -
		APPLICATION SPEC -	CAGE CODE 00779	
		WEIGHT -	DRAWING NO C-619445	
			SCALE 5:1	SHEET 1 OF 1
				REV A