

THIS DRAWING CONTAINS INFORMATION PROPRIETARY TO RF INDUSTRIES.
 ANY UNAUTHORIZED USE OF THIS DRAWING IS EXPRESSLY PROHIBITED
 WITHOUT WRITTEN PERMISSION FROM RF INDUSTRIES.
 ANY VIOLATION IS PUNISHABLE UNDER U.S. COPYRIGHT LAWS.

ALL DIMENSIONS ARE REFERENCE ONLY

PART NO.

RFB-1123-1

REV	DESCRIPTION	DWN	DATE	APPROVED
D	NO DIM CHG TO CONN / CHG STRIP INST / SEP BODY VIEW	CZS	9/23/99	R. RICE
E	CHANGE DIELECTRIC ID DIM	CZS	9/23/99	R. RICE
F	CHANGE FERRULE, FERRULE STUD, CONTACT & DIE CONFIG	CZS	10/28/99	JDMc
G	CHANGE PIN CONFIG., STRIP., DWG.# 8020 & FORMAT	GGG	2/05/02	JDMc

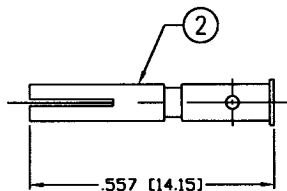
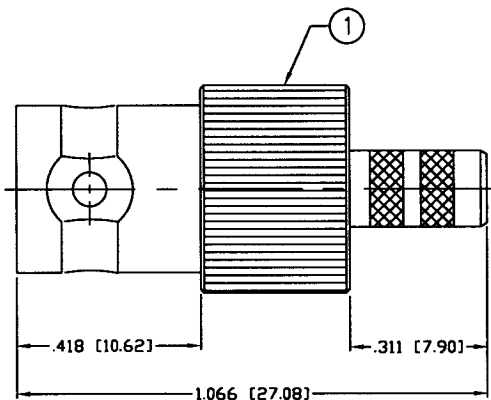

RECOMMENDED CRIMP DIE: .068"

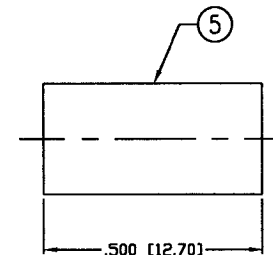

RECOMMENDED CRIMP DIE: .213"

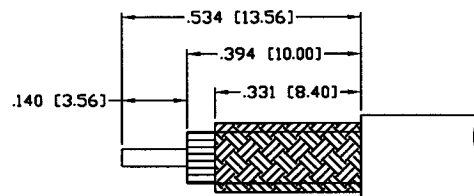

RECOMMENDED STRIPPING DIMENSIONS

SPECIFICATIONS:

IMPEDANCE: 50 Ohms
 FREQUENCY RANGE: 0-4 GHz
 VSWR: 1.3 Max.
 WORKING VOLTAGE: 500 V rms @ sea level
 TEMPERATURE RANGE: -65°C TO 165°C
 INSULATION RESISTANCE: 5k M Ohms min.
 FOR RG-58, 58A, 58C, 141, 141A, BELDEN 8240,
 8262, 9201, 9203, 9310, 9311 & COMM/SCOPE 0268

1	BODY	1	BRASS	NICKEL, 80μ"
2	CONTACT	1	BRASS	GOLD, 3μ"
3	DIELECTRIC	1	PTFE	---
4	WASHER	1	BRASS	NICKEL, 80μ"
5	FERRULE	1	BRASS	NICKEL, 80μ"
6				
7				
8				
9				
10				
11				
12				
13				
14				
#	DESCRIPTION	QTY	MATRL	FINISH

000486	
DRAWN	2/05/02
G. GALLEGOS	
CHECKED	
ORJ DRAWN	5/14/92
C. JONES	
APPROVALS	DATE

UNLESS OTHERWISE SPECIFIED:
 1. REMOVE ALL BURRS
 2. BREAK ALL CORNERS & EDGES .005 R. MAX.
 3. CHAMFER 1ST & LAST THREADS 45°
 4. SURFACE ROUGHNESS 63 FINISH MIL-STD-10
 5. DIAMETERS ON COMMON CENTERS TO BE CONCENTRIC WITHIN .002 T.I.R.
 6. ALL DIMENSIONS ARE AFTER PLATING.

DIMENSIONS ARE IN INCHES AND [MILLIMETERS]
 UNLESS OTHERWISE NOTED TOLERANCES ARE:
 DECIMALS DIAMETER
 .xxx±.003 [.08] .xxx±.001 [.03]
 .xx±.005 [.13] .xx±.003 [.08]

RF connectors
 DIVISION OF RF INDUSTRIES, LTD.

7610 MIRAMAR RD
 SAN DIEGO, CA 92126
 (858) 549-6340
 (858) 549-6345 FAX

BNC JACK CRIMP

SIZE	CABLE GROUP	DWG NO.	REV
A	C	RFB-1123-1	G
SCALE:	NTS	CAD FILE	OUTLINE
			SHEET 1 OF 1