



Flexis™ Series

Flexis AC – 8- and 32-bit compatible MCUs

DEMOACEX expansion board for
all Flexis AC demonstration boards

Before continuing with the DEMOACEX demonstration,
complete these four steps of the DEMOAC Quick Start Guide:

Step 1: Install CodeWarrior® for Microcontrollers

Step 2: Install PEMicro Demo Board Toolkit

Step 3: Connect Board to Computer

Step 4: Test Board by Running Quick Start Application

Get to Know the Flexis™ Expansion Board

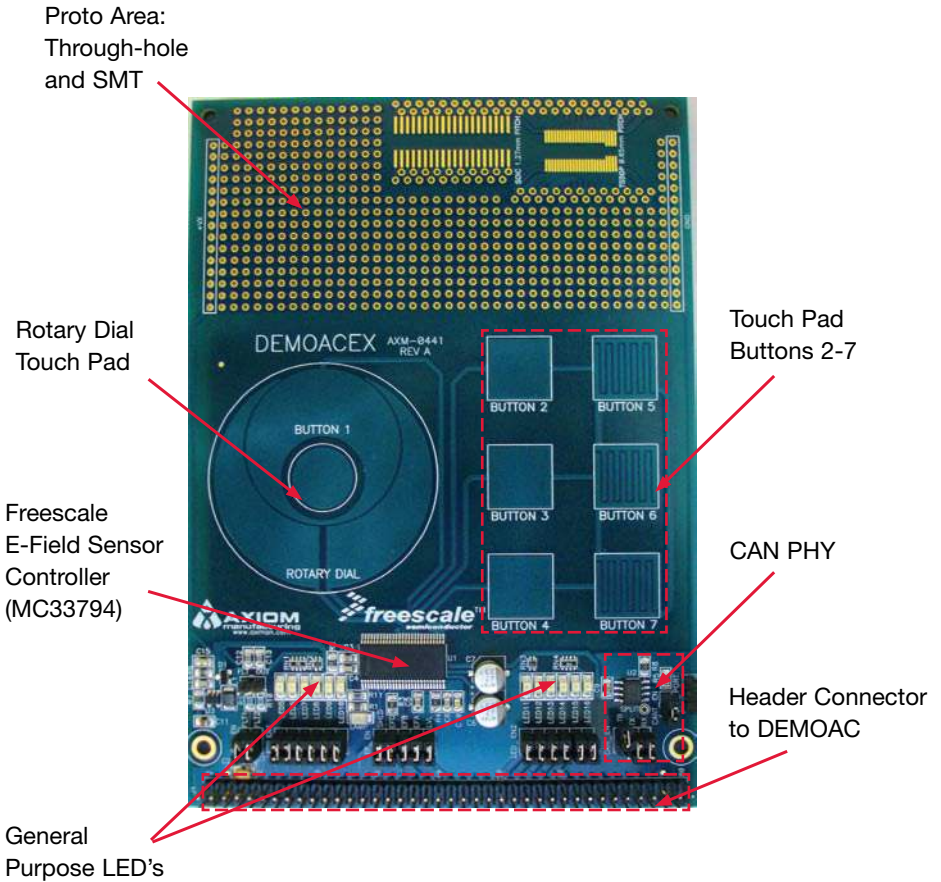

Figure 1. DEMACEX for QSG

Introduction

This quick start guide is designed to get your DEMOACEX expansion board running with any of the DEMOAC kits within minutes. The DEMOAC board comes in several versions depending on the target AC family MCU:

- DEMOS08AC16KIT
- DEMOS08AC60KIT
- DEMOS08AC128KIT
- DEMO51AC256KIT
- DEMOACKIT which includes both the MC9S08AC128 and MCF51AC256

This quick start guide applies to use of the DEMOACEX with all of the DEMOAC versions listed.

Step-by-Step Installation Instructions

To Use the DEMOACEX Demo Program:

Familiarize yourself with these buttons:



Start/Continue (F5) button





Debug button

The DEMOACEX demonstration program executes on DEMOAC board with any AC module installed. To run this demo, the user will have to load the program using CodeWarrior for Microcontrollers Integrated Development Environment (IDE). If CodeWarrior was not installed previously, follow Steps 1-4 in the DEMOAC Quick Start Guide before continuing with the DEMOACEX example.

The DEMOACEX application software can be found on the DVD provided with the DEMOAC. The demo application may also be downloaded from the Axiom Manufacturing web site at www.axman.com/support.

1. Open CodeWarrior for Microcontrollers. From Windows start menu you can locate it using the "Programs>Freescale CodeWarrior>CW for Microcontroller V6.1>CodeWarrior IDE.exe" path.
2. Click on "Load Example Project" from CodeWarrior startup dialog. If the startup dialog is not shown, it may be opened from the CodeWarrior menu by clicking "File" and then "Startup Dialog".
3. From example projects menu, open tree to select the appropriate Accelerometer Application for your DEMOAC board. i.e. "HCS08>Evaluation Board Examples>DEMOAC>DEMO9S08AC128_DEMOACEX." or "ColdFire V1>Evaluation Board Examples>DEMOAC>DEMO51AC256_DEMOACEX."
4. Create a new project name (ex. Lab_EX), set desired location and click "Create Project". This will open the project for the DEMOACEX application for the selected AC family device.

5. Ensure the correct AC family microcontroller daughter card is installed on the DEMOAC board.
6. Ensure the DEMOACEX is securely connected to the DEMOAC board and is configured for default operation. Refer to Figure 1.
7. Turn board power switch to ON.
8.  Compile and program the logic analyzer application by clicking on “Debug” button.
9. From Connection Manager menu, select “DEMOAC on USB1 (Name=PEnnnnnnn)” port (or “USB1:DEMOAC(PEnnnnnnn)” port if using the MCF51AC256) and click on “Connect (Reset).”
10. From Loader Warning menu, click on “OK” to allow the debugger to mass erase the microcontroller’s on-chip flash memory and program it with the new application.
11.  Click on “Start/Continue (F5)” button in debugger to run application.
12. On the DEMOACEX, touch each of the e-field touch pad buttons 2-7 and notice 1 or more of LEDs 1-3 light. Touching and moving your finger around the rotary dial cycles through LEDs 5-10. Pressing button 1 toggles the state of LEDs 5-10. Use the potentiometer on the DEMOAC board to adjust the sensitivity of the e-field pads.

For more information on the DEMOACEX Board read the board user manual (DEMOACEX_UM.pdf) on www.freescale.com/flexis or on the DVD under Documentation > Development System Documentation > DEMOACEX User Manual of the DVD menu.

Troubleshooting

If the demonstration application fails to function as indicated above, please follow the steps below before contacting Freescale Semiconductors. Please refer to the TIC card included in the DEMOACEX kit for contact information.

- Ensure the correct version of CodeWarrior and all that available Service Packs are installed
- Ensure the DEMOACEX is properly configured; refer to Figure 1 above.
- Ensure the DEMOAC is properly configured; refer to the DEMOAC Quick Start Guide for details.
- Ensure the DEMOAC board PWRSW is set to the ON position.
- Ensure the LAMP LED is ON.
- Verify the +5V voltage indicator on the DEMOAC is ON.

Quick Board References

Default Settings

The DEMOACEX is a peripheral board designed for use with the DEMOAC board. The DEMOACEX highlights the MC33794 E-Field Sensor. Touch-pads of various configurations provide sensor input. Refer to the DEMOAC Quick Start Guide to install CodeWarrior Development Studio and to setup and configure the DEMOAC Board.

The default jumper settings for the DEMOACEX are shown below

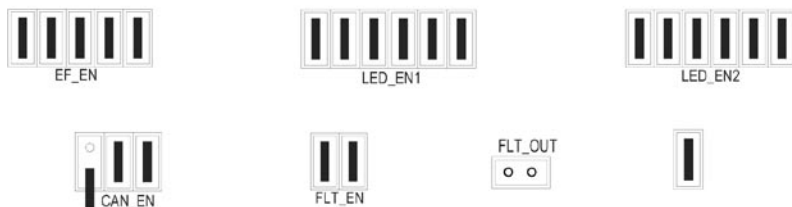

Figure 1: DEMOACEX Default Settings



Learn More: For more information about
Freescale products, please visit
www.freescale.com/coldfire.

Freescale and the Freescale logo are trademarks or registered trademarks of Freescale Semiconductor, Inc. in the U.S. and other countries. All other product or service names are the property of their respective owners. © Freescale Semiconductor, Inc. 2008.

Doc Number: FLXACEXBDMOQSG / REV 0
Agile Number: 926-77694 / REV A

