

LOC	QTY	REV	DESCRIPTION	DATE	BY	APPD
HK	00	D	INITIAL RELEASE	02DEC2003	RMP	RMP

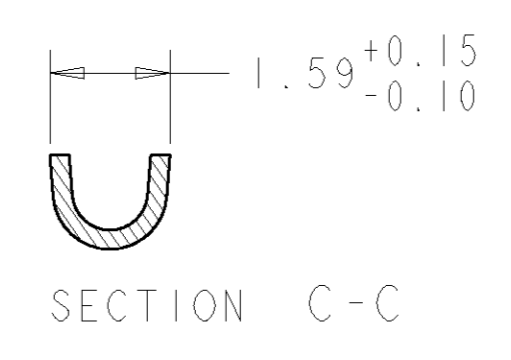
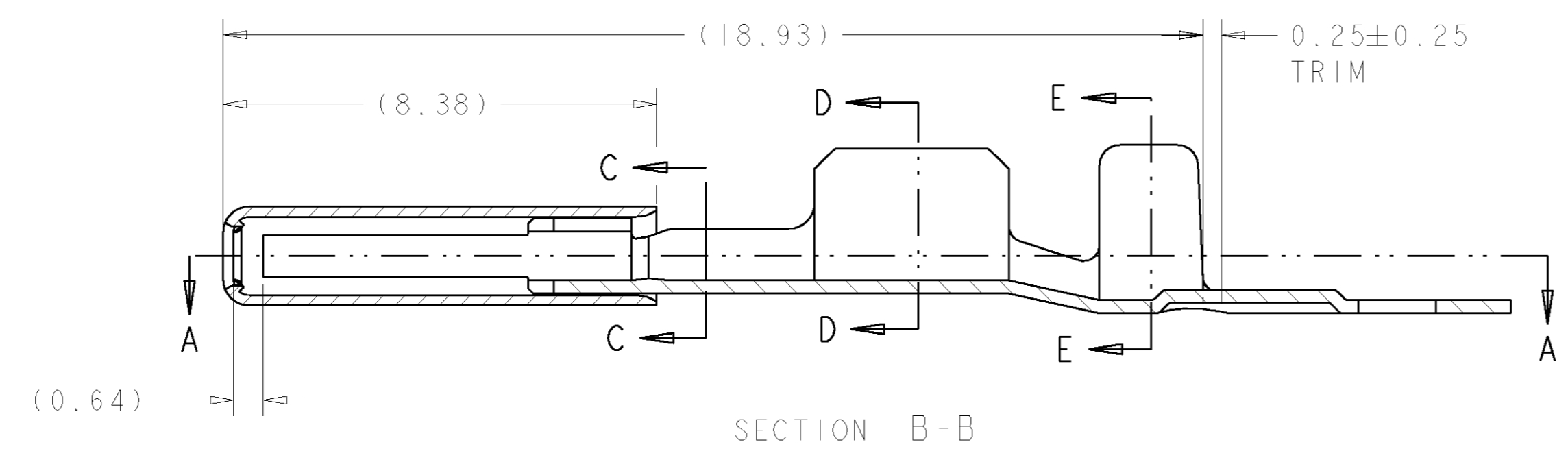
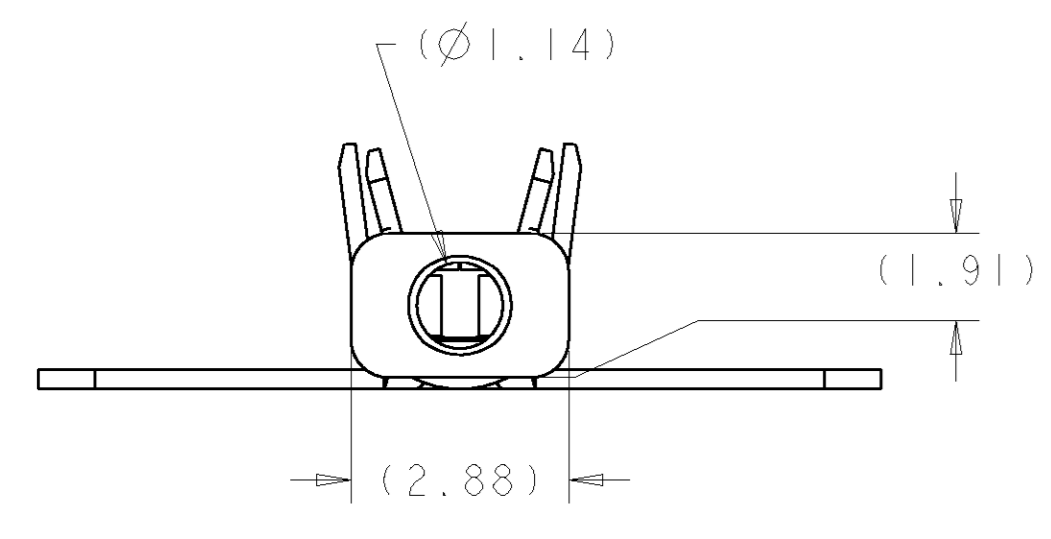
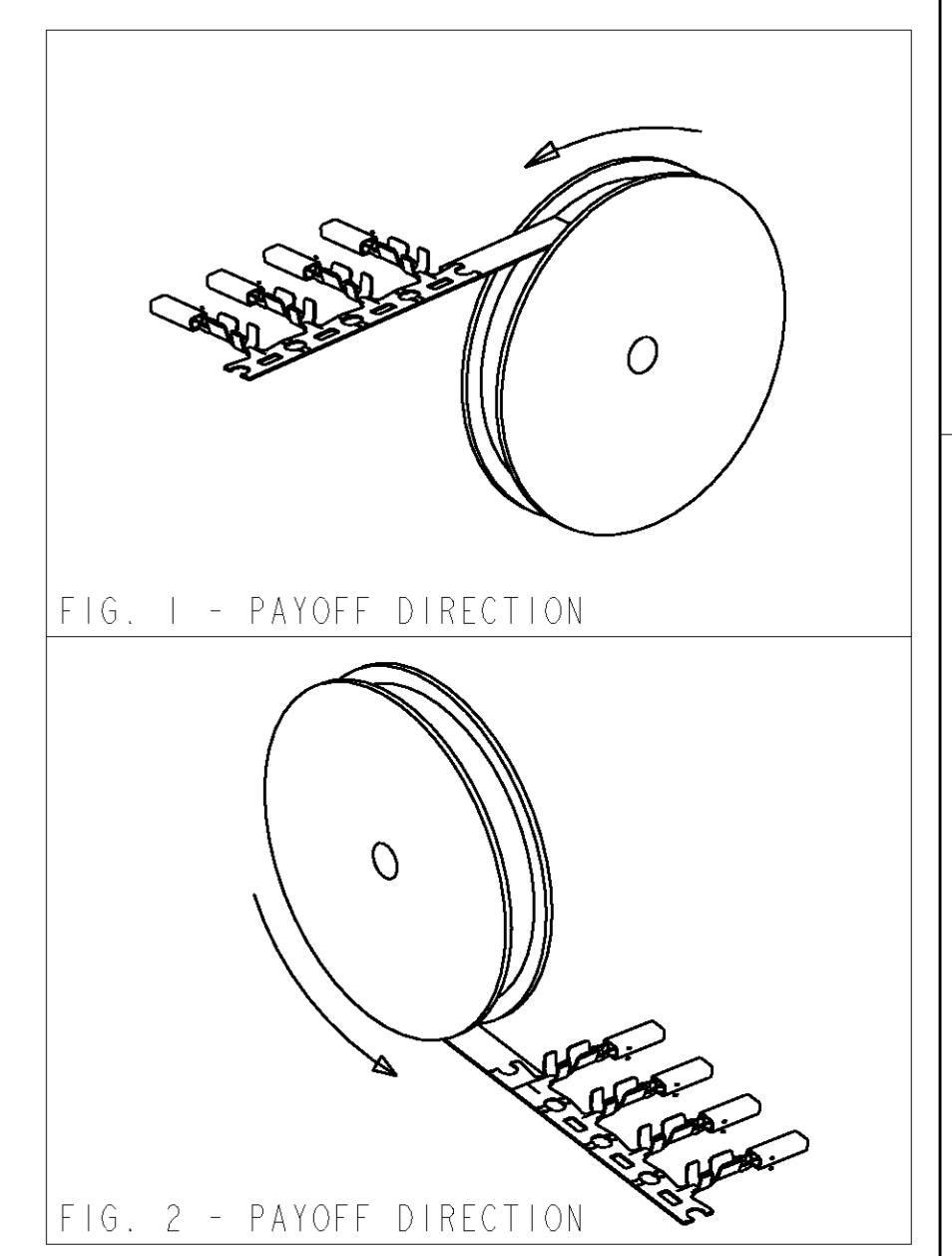
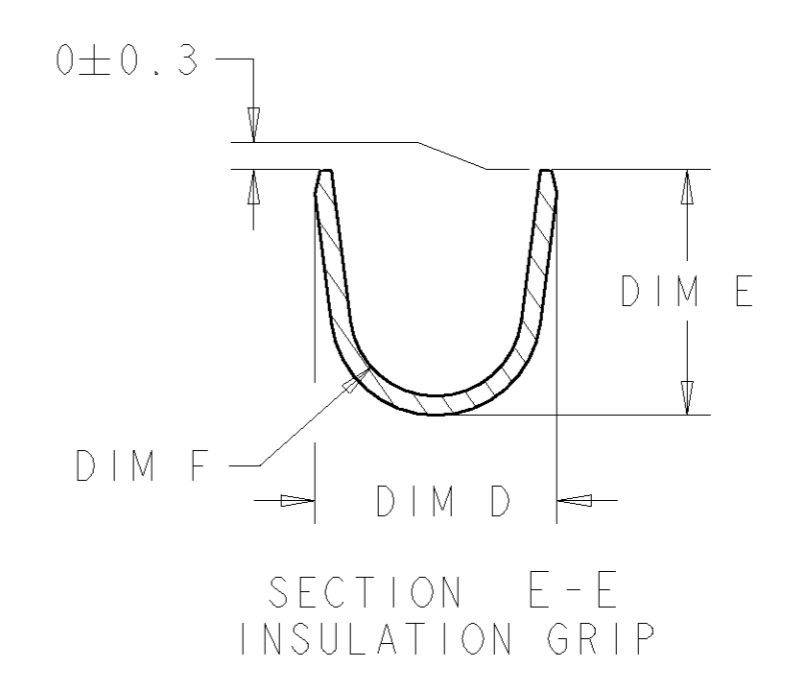
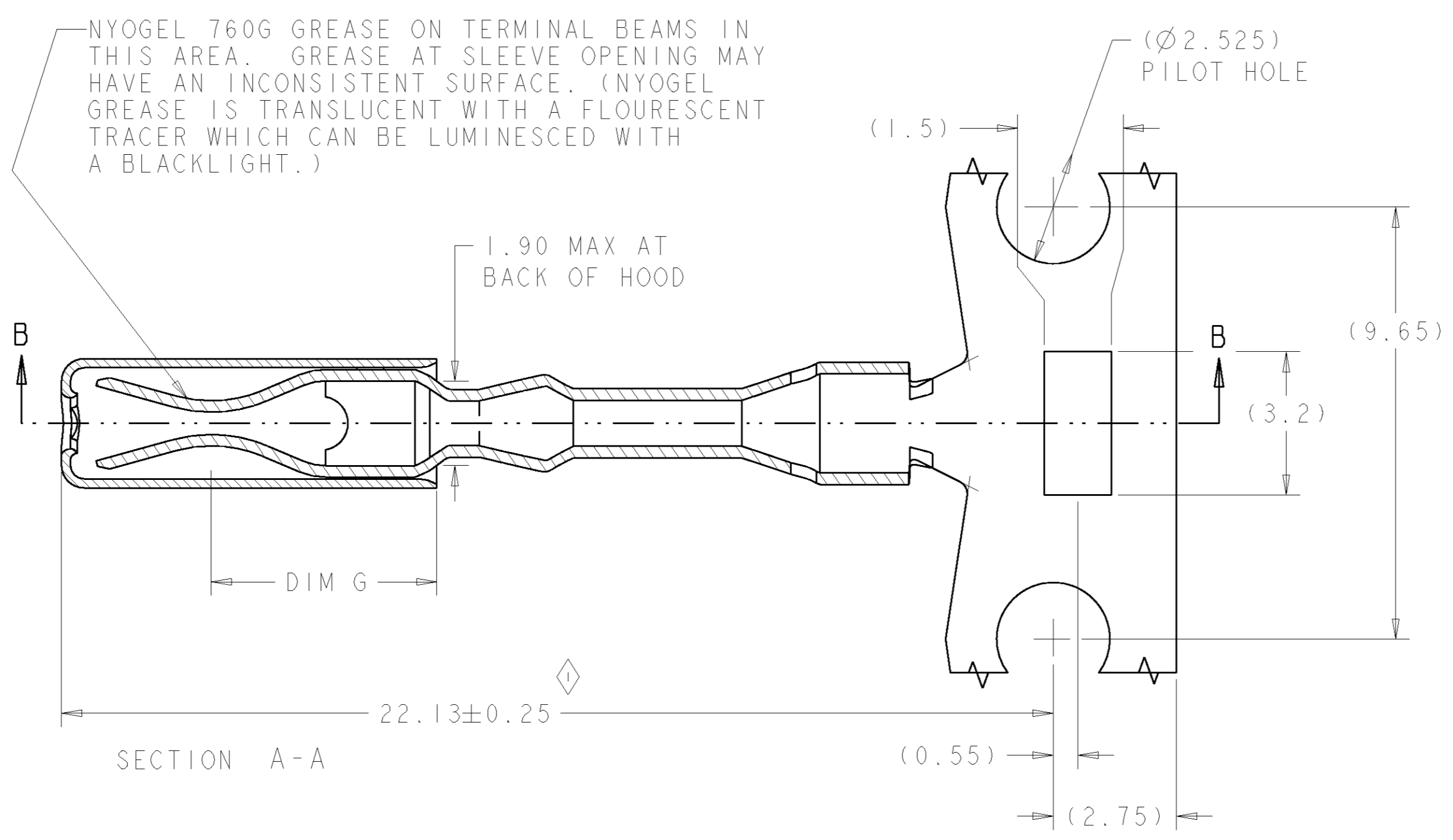
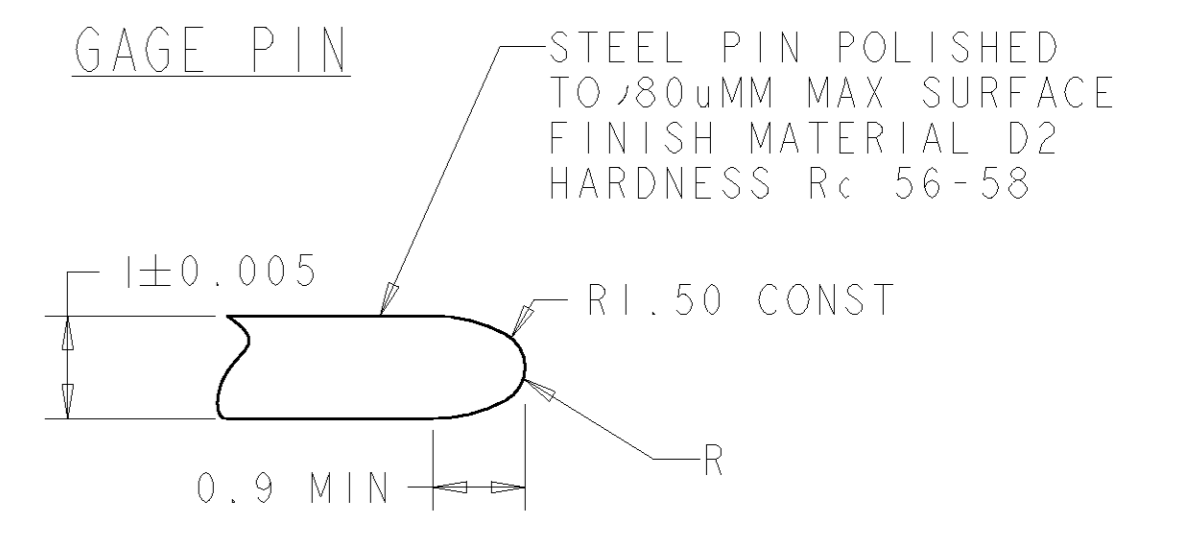
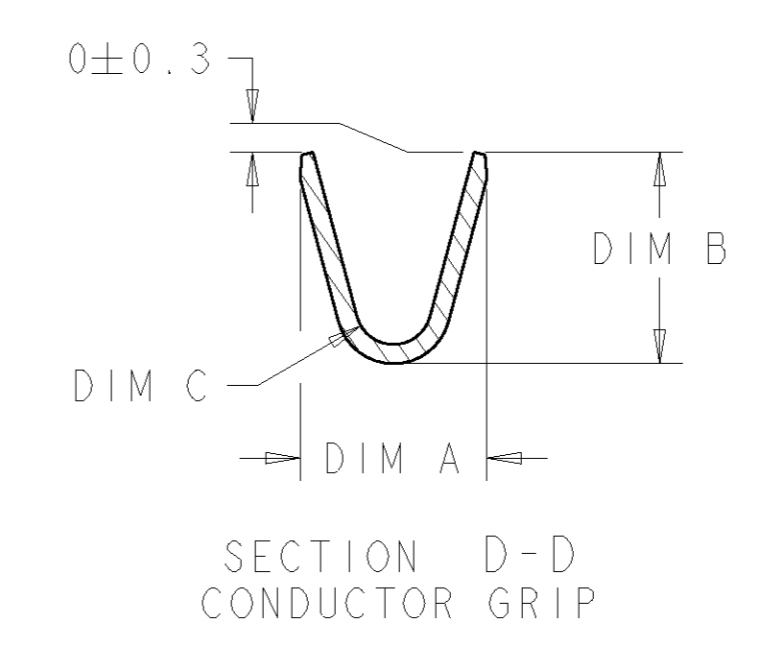
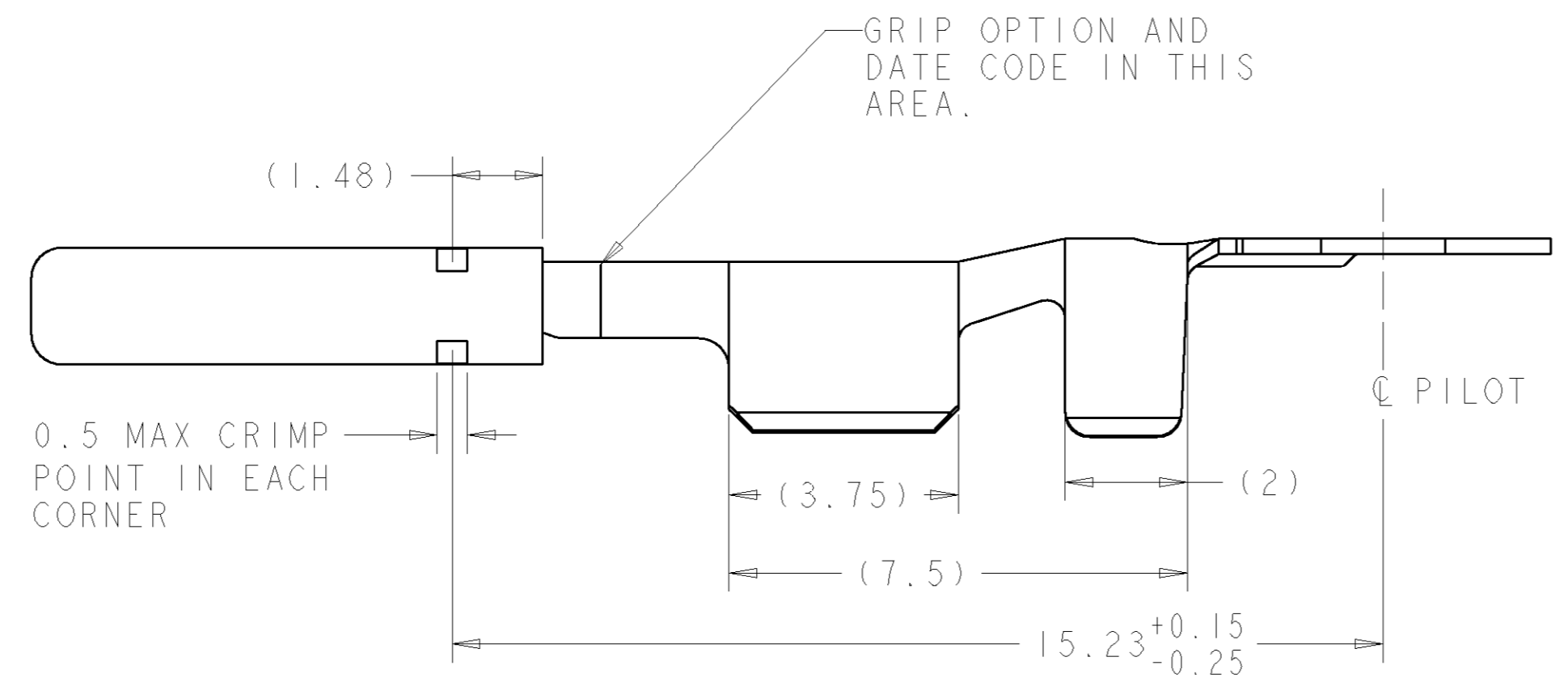
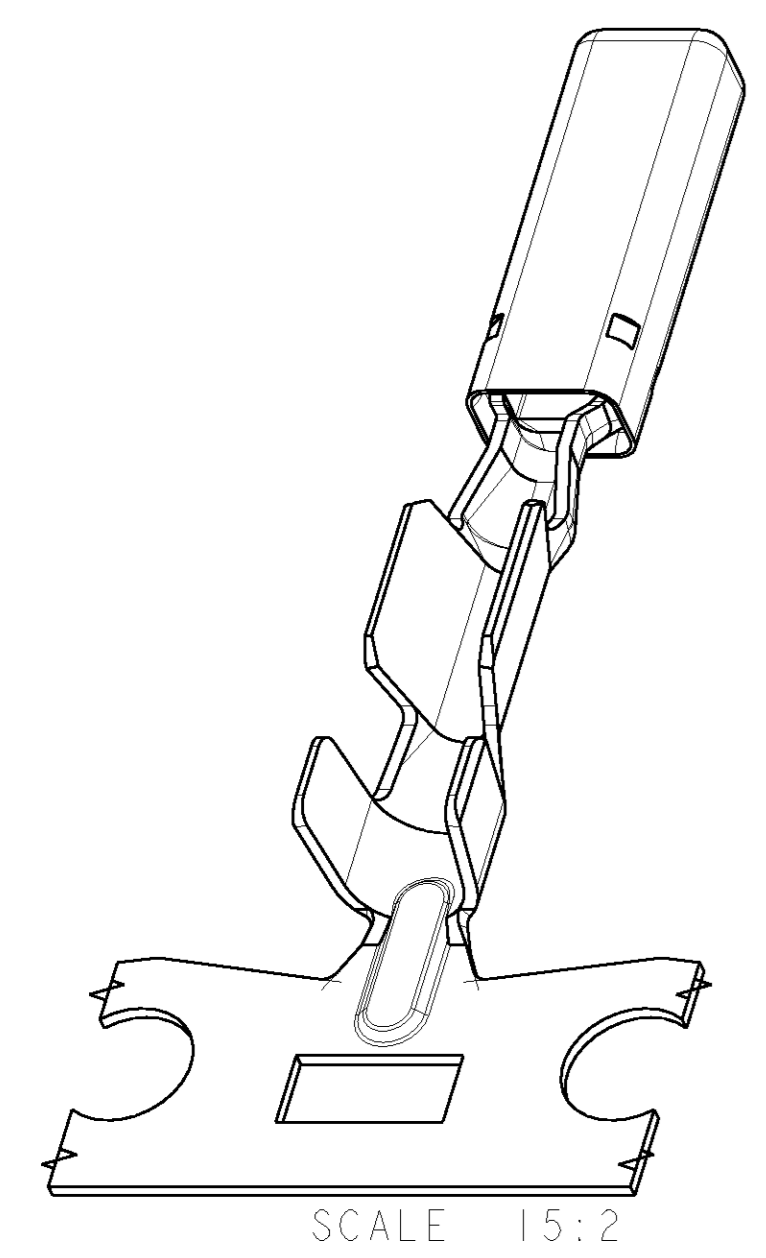

COMPONENTS	DRAWING NUMBER
TIN TERMINAL BODY	1378960
TERMINAL SLEEVE	1378739

NAME	CHRYSLER PART NUMBER	TYCO PART NUMBER	WINDING DIRECTION
FINAL ASSEMBLY - TIN 20AWG		1456350-2	FIG. 2
FINAL ASSEMBLY - TIN 18AWG		1456350-1	FIG. 2
FINAL ASSEMBLY - TIN 20AWG	04801229AA-22	1454333-8	FIG. 1
FINAL ASSEMBLY - TIN 18AWG	04801229AA-18	1454333-7	FIG. 1

CHRYSLER PART NUMBER	CONTACT PLATING	SLEEVE PLATING TYPE	WIRE SIZE (MS-7889, MS-8288 or MS-9502)	INSULATION CRIMP		CONDUCTOR CRIMP			GRIP DIMENSIONS						CONTACT DIMENSION	
				CRIMP WIDTH	CRIMP HEIGHT	CRIMP WIDTH	CRIMP HEIGHT	STRIP LENGTH	GRIP CODE	A	B	C	D	E		F
04801229AA-18	TIN	BRIGHT TIN (OPTIONAL POST PLATING - NICKEL)	16	2.75	2.15	2.05	1.32	4	18 AWG	3.0	3.1	Ø1.00	3.8	3.25	Ø1.75	(5.01)
04801229AA-18			18	2.10	1.15											
04801229AA-22			20	1.95	1.05											

TOLERANCE OF ±0.05 FOR ALL GRIPS
 TOLERANCE OF ±0.3 FOR ALL GRIP DIMENSIONS

DIMENSIONS: mm		TOLERANCES UNLESS OTHERWISE SPECIFIED:		DWN RMP 02DEC2003		CHK RMP 02DEC2003		APPD RMP 02DEC2003		Tyco Electronics Harrisburg, PA 17105-3608	
9 PLC ±0.30 1 PLC ±0.20 2 PLC ±0.10 3 PLC ±0.10 4 PLC ±0.10 ANGLES ±0.10		FINISH: --		PRODUCT SPEC: --		APPLICATION SPEC: --		WEIGHT: --		NAME: USCAR TIN TERMINAL SIZE: A1 CAGE CODE: 00779 DRAWING NO: 9-1437847-2 RESTRICTED TO: --	
MATERIAL: SEE NOTES		FINISH: --		CUSTOMER DRAWING		SCALE: N/A		SHEET: 1 OF 2		REV: D	

LOC	DIST	REV	DATE	BY	APPD
HK	00				

COPYRIGHT DAIMLERCHRYSLER CORPORATION 04-06-2000
 ELECTRICAL CATIA COMMENT PAGE

IT IS MANDATORY TO COMPLETE SEC #1, #2 AND REVISION BLOCK (LAST SECT.)

SECTION 1: TITLE BLOCK INFORMATION

PART NO.: 04707889AA MODEL: 1 OF 1 TRIM NO: N/A
 TITLE: CHART - TERMINAL 1.0MM FEMALE
 LAST PCL: F LAST DCL: F STANDARD UNIT= MM.
 DATE STARTED: 09-26-00 YR-MOD: 1999NS
 UPG CODE: 79E01D DEPT NO.: 9730
 VSC: 36510 DEPT. NAME: MVP ELECTRICAL
 DESIGNER: S.FOSTER CHECKER: A.TRAPPE
 ENGINEER: J.COELING FILE NAME: CDM
 SENIOR ENG.: S.MASON MAINFRAME: CTC
 MATERIAL TYPE: N/A MATERIAL FIN: N/A WEIGHT: N/A
 MATERIAL THK: N/A MAT'L DIRECTION SEE SECTION: N/A
 NOMINAL MATL THK: N/A

ITEM NUMBER	STANDARDS NAME	!APVD
1	!MS-8570, C7026 H07	!MATERIAL STANDARD
2	!MS-8570, C2600 H02	!MATERIAL STANDARD
3	!PS-7300	!QUALITY ASSURANCE DIAMONDS
4	!PF-9600	!AUTO ELEC CONNECTOR PERFORM STDS
5	!PS-9227	!CAD/CAM DATA EXCHANGE POLICY
6	!CEP-002	!CATIA STANDARDS MANUAL
7	!PS-10052	!INFORMATION SECURITY
8	!CS-9003	!ENVR, HEALTH AND OCC SAFETY REQ.

SECTION 2: CRITICAL CHARACTERISTICS

ANTI-THEFT (Y OR N): N DIAMONDS (Y OR N): Y
 EMISSIONS (Y OR N): N PENTAGONS (Y OR N): N
 SAFETY (Y OR N): N

SECTION 3: GENERAL REF. INFORMATION

PLATED MATERIAL BEFORE FORMING:

- TIN PLATING: 35-75 MICRO INCHES THICK OF TIN PER ASTM B-547-83.

SECTION 4: GENERAL ENGINEERING NOTES

- PART TO BE FREE OF BURRS, DIE MARKS, OR ANY OTHER IMPERFECTIONS WHICH COULD AFFECT PART FUNCTION.
- PLATING TO BE FREE OF ORANGE PEEL OR ANY OTHER IMPERFECTION DUE TO DIE OR HANDLING WHICH COULD ADVERSELY AFFECT PART FUNCTION.
- PART TO BE FREE OF SHARP EDGES WHICH COULD TEAR THE SEAL DURING SUBSEQUENT OPERATIONS.
- WIRE HARNESS SUPPLIERS MUST PURCHASE COMPONENT FROM SOURCES SHOWN.
- TERMINAL SLEEVE MUST WITHSTAND 100 NEWTONS PULL-OFF FORCE.
- SLEEVE PLATING - BRIGHT TIN 30 MICRO INCHES MINIMUM THICKNESS. (OPTIONAL POST PLATING - NICKEL 100 MICRO INCHES MAXIMUM)
- QUALITY ASSURANCE REQUIREMENTS PER ITEM #3.
- DAIMLER/CHRYSLER DEVIATION TO ITEM #4 (PF-9600): TEST 5.2.2 - TERMINAL BEND RESISTANCE TO BE 10N.

SECTION 5: ENGINEERING SHORTAGES
 (MISSING INFORMATION ON PRELIMINARY RELEASED PARTS)

CHRYSLER PART NUMBER:
 04707890AA 04707890AA 04707890AA 04801229AA 04801229AA 04801229AA
 -18 -18 -22 -18 -18 -22
 CONTACT VERSION:
 GOLD GOLD GOLD TIN TIN TIN
 SLEEVE PLATING TYPE:
 UNPLATED UNPLATED UNPLATED BRIGHT TIN BRIGHT TIN BRIGHT TIN
 WIRE SIZE (MS-7889, MS-8288, OR MS-9502):
 16 18 20 16 18 20
 INSULATION CRIMP WIDTH:
 2.75 2.75 2.0 2.75 2.75 2.0
 INSULATION CRIMP HEIGHT:
 2.15 2.10 1.95 2.15 2.10 1.95
 CONDUCTOR CRIMP WIDTH:
 2.05 2.05 1.65 2.05 2.05 1.65
 CONDUCTOR CRIMP HEIGHT:
 1.40 1.25 1.1 1.40 1.25 1.1
 STRIP LENGTH:
 4 4 4 4 4 4

CHRYSLER PART NUMBER:
 04801229AA 04801229AA
 -18 -22

GRIP CODE:

	18 AWG	22 AWG
A	3.0	2.6
B	3.1	2.5
C	1.00 DIA	0.75 DIA
D	3.8	3.2
E	3.25	2.6
F	1.75 DIA	1.4 DIA
G	(5.01)	(5.01)

TOLERANCE OF 0.3 FOR ALL GRIP DIMENSIONS

SECTION 6: ASSEMBLY INFORMATION (PLOT USING /M COMMENT)

THIS ASSEMBLY CONSISTS OF:
 ITEM !PART NO. !CHG !QTY !TITLE
 !SHOWN ON !PART REFERENCE INFORMATION (OPTIONAL)

ITEM	!PART NO.	!CHG	!QTY	!TITLE
A				

SECTION 7: SHOWN ON INFORMATION

PART NO.	!CHG	!TITLE	!APPLY STDS PER ITEM NO'S
04707890AA-18!F		!1.0MM FEMALE TERMINAL, 16 AWG, GOLD CONTACT	
04707890AA-18!F		!1.0MM FEMALE TERMINAL, 18 AWG, GOLD CONTACT	
04707890AA-22!F		!1.0MM FEMALE TERMINAL, 20 AWG, GOLD CONTACT	
04801229AA-18!F		!1.0MM FEMALE TERMINAL, 16 AWG, TIN CONTACT	
04801229AA-18!F		!1.0MM FEMALE TERMINAL, 18 AWG, TIN CONTACT	
04801229AA-22!F		!1.0MM FEMALE TERMINAL, 20 AWG, TIN CONTACT	

SECTION 8: REVISION BLOCK INFORMATION

AUTHORITY	!DES!CHK!SUP!ENG!GDT!PLP!CMM!WELD!PPAP!	!MO/DY/YEAR
0-1	!SLF!JBS!SLM!DRK!	!07/21/1997
!A	!PRODUCTION RELEASE	
80116-M03	!SLF!JBS!SLM!DRK!	!01/15/1998
!B	!REVISED PLATING NOTES 35-75 MICRO INCHES TIN WAS 175-125 MICRO INCHES TIN (2 PLACES).	
80515-M01	!SLF!SAM!SLM!DRK!	!06/02/1998
!C	!UPDATE TERMINAL CHART TO REFLECT NEW 16 GAUGE GRIP DIMENSIONS.	
90722-M03	!SLF!AKT!SLM!JKC!	!07/20/1999
!D	!UPDATE TERMINAL CHART TO REFLECT NEW GRIP DIMENSIONS.	
00628-M03	!JF !RKB!SLM!JKC!	!09/26/2000
!E	!REVISE 10MM TERMINAL USAGE TO IMPROVE CRIMP CAPABILITY.	
00918-M13	!NS !KP !SLM!JKC!	!11/27/2000
!F	!ADDED NOTE TO SLEEVE PLATING: OPTIONAL POST PLATING - NICKEL. !ADDED SECTION C-C.	

DIMENSIONS:		TOLERANCES UNLESS OTHERWISE SPECIFIED:		DWN RMP 02DEC2003	
mm		9 PLC ±0.30		CHK RMP 02DEC2003	
		1 PLC ±0.20		APPD RMP 02DEC2003	
		2 PLC ±0.10		NAME	
		3 PLC ±0.10		USCAR TIN TERMINAL & DWG_TITLE_2	
		4 PLC ±0.10		PRODUCT SPEC	
		ANGLES		APPLICATION SPEC	
MATERIAL		FINISH		SIZE CAGE CODE DRAWING NO	
				A 00779 C=9-1437847-2	
				RESTRICTED TO	
				WEIGHT	
				CUSTOMER DRAWING	
				SCALE N/A SHEET 2 OF 2 REV D	