

Low voltage 8-bit constant current LED sink with full outputs error detection

Datasheet - production data

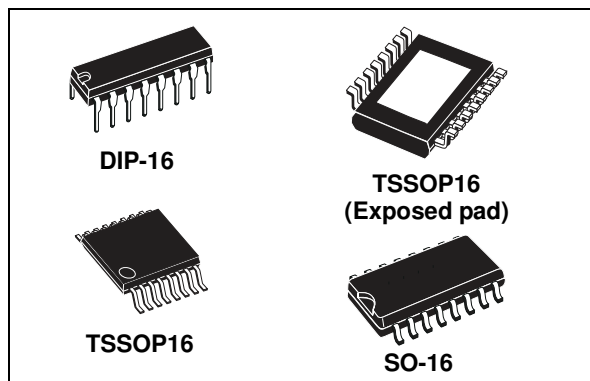

serial-in, parallel-out shift register that feeds a 8-bit D-type storage register. In the output stage, eight regulated current sources were designed to provide 5-100 mA constant current to drive the LEDs.

The STP08DP05 is backward compatible in the functionality and footprint with STP8C/L596 and extends its functionality with open and short detection on the outputs. The detection circuit checks 3 different conditions that can occur on the output line: short to GND, short to V_O or open line. The data detection results are loaded in the shift register and shifted out via the serial line output.

The detection functionality is implemented without increasing the pin number, through a secondary function of the output enable and latch pin (DM1 and DM2 respectively), a dedicated logic sequence allows the device to enter or leave from detection mode. Through an external resistor, users can adjust the STP08DP05 output current, controlling in this way the light intensity of LEDs, in addition, user can adjust LED's brightness intensity from 0% to 100% via $\overline{OE}/DM2$ pin.

The STP08DP05 guarantees a 20 V output driving capability, allowing users to connect more LEDs in series. The high clock frequency, 30 MHz, also satisfies the system requirement of high volume data transmission. The 3.3 V of voltage supply is well useful for applications that interface any micro from 3.3 V. Compared with a standard TSSOP package, the TSSOP exposed pad increases heat dissipation capability by a 2.5 factor.

Features

- Low voltage power supply down to 3 V
- 8 constant current output channels
- Adjustable output current through external resistor
- Short and open output error detection
- Serial data IN/parallel data OUT
- 3.3 V micro driver-able
- Output current: 5-100 mA
- 30 MHz clock frequency
- Available in high thermal efficiency TSSOP exposed pad
- ESD protection 2.5 kV HBM, 200 V MM

Description

The STP08DP05 is a monolithic, low voltage, low current power 8-bit shift register designed for LED panel displays. The STP08DP05 contains a 8-bit

Table 1. Device summary

Order codes	Package	Packaging
STP08DP05B1R	DIP-16	25 parts per tube
STP08DP05MTR	SO-16 (Tape and reel)	2500 parts per reel
STP08DP05TTR	TSSOP16 (Tape and reel)	2500 parts per reel
STP08DP05XTTR	TSSOP16 exposed-pad (Tape and reel)	2500 parts per reel

Contents

1	Summary description	3
	1.1 Pin connection and description	3
2	Block diagram	4
3	Maximum rating	5
	3.1 Absolute maximum ratings	5
	3.2 Thermal data	5
	3.3 Recommended operating conditions	6
4	Electrical characteristics	7
5	Switching characteristics	8
6	Equivalent circuit and outputs	9
7	Truth table and timing diagram	10
	7.1 Truth table	10
	7.2 Timing diagram	10
8	Typical characteristics	13
9	Test circuit	15
10	Detection mode functionality	17
	10.1 Phase one: “entering in detection mode”	17
	10.2 Phase two: “error detection”	17
	10.3 Phase three: “resuming to normal mode”	19
	10.4 Error detection conditions	19
11	Package mechanical data	21
12	Packaging mechanical data	30
13	Revision history	31

1 Summary description

Table 2. Typical current accuracy

Output voltage	Current accuracy		Output current
	Between bits	Between ICs	
≥1.3 V	±1.5%	±5%	20 to 100 mA

1.1 Pin connection and description

Figure 1. Connections diagram

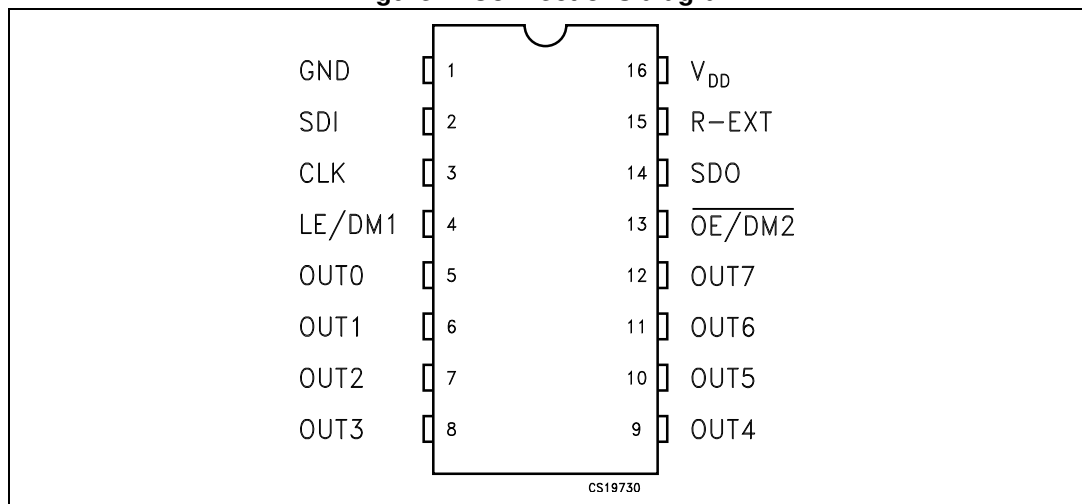

Note: The exposed pad should be electrically connected to a metal land electrically isolated or connected to ground.

Table 3. Pin description

Pin n°	Symbol	Name and function
1	GND	Ground terminal
2	SDI	Serial data input terminal
3	CLK	Clock input terminal
4	LE/DM1	Latch input terminal
5-12	OUT 0-7	Output terminal
13	$\overline{\text{OE/DM2}}$	Output enable input terminal (active low)
14	SDO	Serial data out terminal
15	R-EXT	Constant current programming
16	V _{DD}	5 V supply voltage terminal

2 Block diagram

Figure 2. Normal mode - block diagram

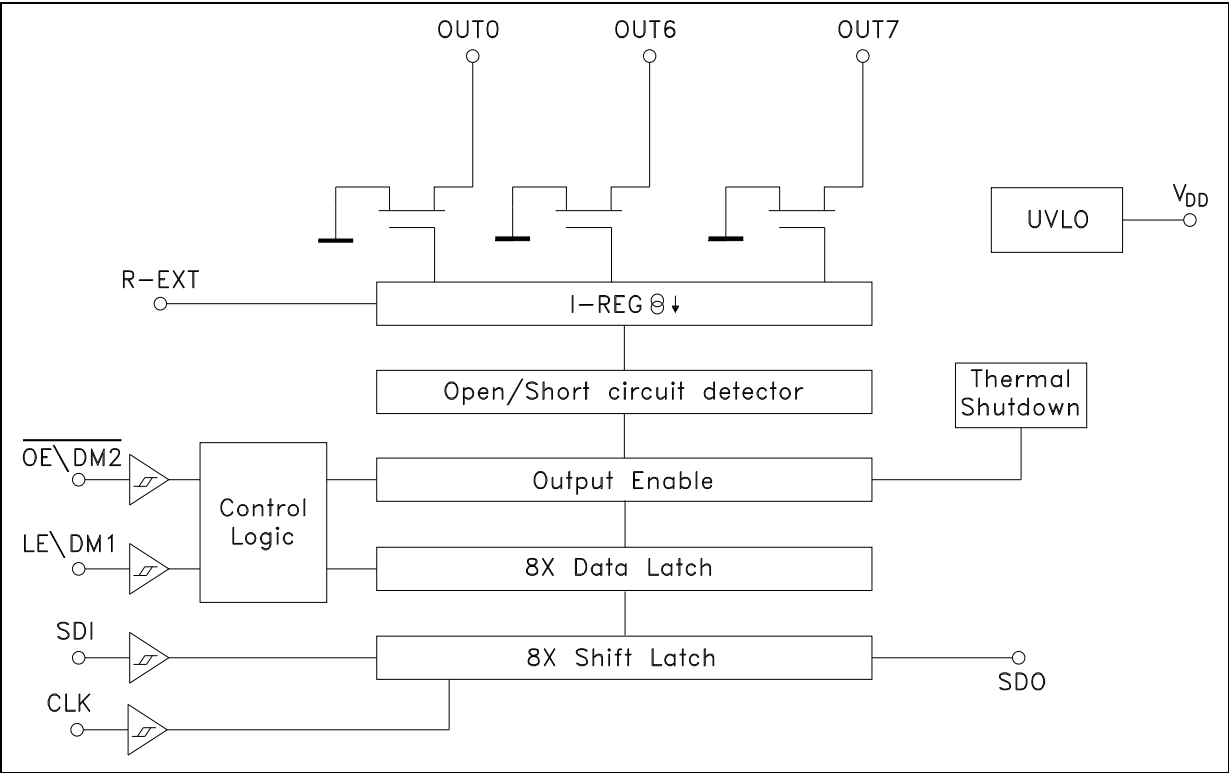

3 Maximum rating

Stressing the device above the rating listed in the “absolute maximum ratings” table may cause permanent damage to the device. These are stress ratings only and operation of the device at these or any other conditions above those indicated in the operating sections of this specification is not implied. Exposure to absolute maximum rating conditions for extended periods may affect device reliability.

3.1 Absolute maximum ratings

Table 4. Absolute maximum ratings

Symbol	Parameter	Value	Unit
V_{DD}	Supply voltage I_{GND}	0 to 7	V
V_O	Output voltage	-0.5 to 20	V
I_O	Output current	100	mA
I_{GND}	GND terminal current	800	mA
f_{CLK}	Clock frequency	50	MHz
T_{OPR}	Operating temperature range	-40 to +125	°C
T_{STG}	Storage temperature range	-55 to +150	°C

3.2 Thermal data

Table 5. Thermal data

Symbol	Parameter	DIP-16	SO-16	TSSOP-16	TSSOP-16 ⁽¹⁾ (exposed pad)	Unit
R_{thJA}	Thermal resistance junction-ambient	90	125	140	37.5	°C/W

1. The exposed-pad should be soldered to the PBC to realize the thermal benefits

3.3 Recommended operating conditions

Table 6. Recommended operating conditions

Symbol	Parameter	Test conditions	Min.	Typ.	Max.	Unit
V_{DD}	Supply voltage		3.0	-	5.5	V
V_O	Output voltage			-	20	V
I_O	Output current	OUTn	5	-	100	mA
I_{OH}	Output current	SERIAL-OUT		-	+1	mA
I_{OL}	Output current	SERIAL-OUT		-	-1	mA
V_{IH}	Input voltage		$0.7V_{DD}$	-	$V_{DD}+0.3$	V
V_{IL}	Input voltage		-0.3	-	$0.3V_{DD}$	V
t_{wLAT}	LE/DM1 pulse width	$V_{DD} = 3.0 \text{ to } 5.0\text{V}$	20	-		ns
t_{wCLK}	CLK pulse width		20	-		ns
t_{wEN}	$\overline{OE/DM2}$ pulse width		200	-		ns
$t_{SETUP(D)}$	Setup time for DATA		7	-		ns
$t_{HOLD(D)}$	Hold time for DATA		4	-		ns
$t_{SETUP(L)}$	Setup time for LATCH		15	-		ns
f_{CLK}	Clock frequency	Cascade operation ⁽¹⁾		-	30	MHz

1. If the device is connected in cascade, it may not be possible to achieve the maximum data transfer. Please consider the timings carefully.

4 Electrical characteristics

$V_{DD} = 3.3 \text{ V to } 5 \text{ V}$, $T = 25 \text{ }^\circ\text{C}$, unless otherwise specified.

Table 7. Electrical characteristics

Symbol	Parameter	Test conditions	Min.	Typ.	Max.	Unit
V_{IH}	Input voltage high level		$0.7 V_{DD}$		V_{DD}	V
V_{IL}	Input voltage low level		GND		$0.3 V_{DD}$	V
I_{OH}	Output leakage current	$V_{OH} = 20 \text{ V}$		0.5	10	μA
V_{OL}	Output voltage (Serial-OUT)	$I_{OL} = 1 \text{ mA}$		0.03	0.4	V
V_{OH}	Output voltage (Serial-OUT)	$I_{OH} = -1 \text{ mA}$	$V_{OH} - V_{DD} = -0.4\text{V}$			V
I_{OL1}	Output current	$V_O = 0.3 \text{ V}$, $R_{ext} = 3.9 \text{ k}\Omega$	4.25	5	5.75	mA
I_{OL2}		$V_O = 0.3 \text{ V}$, $R_{ext} = 970 \Omega$	19	20	21	
I_{OL3}		$V_O = 1.3 \text{ V}$, $R_{ext} = 190 \Omega$	96	100	104	
ΔI_{OL1}	Output current error between bit (All Output ON)	$V_O = 0.3 \text{ V}$, $R_{EXT} = 3.9 \text{ k}\Omega$		± 5	± 8	%
ΔI_{OL2}		$V_O = 0.3 \text{ V}$, $R_{EXT} = 970 \Omega$		± 1.5	± 3	
ΔI_{OL3}		$V_O = 1.3 \text{ V}$, $R_{EXT} = 190 \Omega$		± 1.2	± 3	
$R_{SIN(up)}$	Pull-up resistor		150	300	600	$\text{k}\Omega$
$R_{SIN(down)}$	Pull-down resistor		100	200	400	$\text{k}\Omega$
$I_{DD(OFF1)}$	Supply current (OFF)	$R_{EXT} = 980$ OUT 0 to 7 = OFF		4	5	mA
$I_{DD(OFF2)}$		$R_{EXT} = 250$ OUT 0 to 7 = OFF		11.2	13.5	
$I_{DD(ON1)}$	Supply current (ON)	$R_{EXT} = 980$ OUT 0 to 7 = ON		4.5	5	
$I_{DD(ON2)}$		$R_{EXT} = 250$ OUT 0 to 7 = ON		11.7	13.5	
Thermal	Thermal protection ⁽¹⁾			170		$^\circ\text{C}$

1. Guaranteed by design (not tested)
The thermal protection switches OFF only the outputs current

5 Switching characteristics

$V_{DD} = 5\text{ V}$, $T = 25\text{ }^{\circ}\text{C}$, unless otherwise specified.

Table 8. Switching characteristics

Symbol	Parameter	Test conditions		Min.	Typ.	Max.	Unit	
t_{PLH1}	Propagation delay time, CLK-OUTn, LE\DM1 = H, OE\DM2 = L	$V_{DD} = 3.3\text{ V}$ $V_{IL} = \text{GND}$ $I_O = 20\text{ mA}$ $R_{EXT} = 1\text{ K}\Omega$	$V_{IH} = V_{DD}$ $C_L = 10\text{ pF}$ $V_L = 3.0\text{ V}$ $R_L = 60\text{ }\Omega$	$V_{DD} = 3.3\text{ V}$		36	46.8	ns
				$V_{DD} = 5\text{ V}$		19	24.7	
t_{PLH2}	Propagation delay time, LE\DM1 -OUTn, OE\DM2 = L			$V_{DD} = 3.3\text{ V}$		38	49.4	ns
				$V_{DD} = 5\text{ V}$		21	27.3	
t_{PLH3}	Propagation delay time, OE\DM2-OUTn, LE\DM1 = H			$V_{DD} = 3.3\text{ V}$		42	54	ns
				$V_{DD} = 5\text{ V}$		23	30	
t_{PLH}	Propagation delay time, CLK-SDO			$V_{DD} = 3.3\text{ V}$		22	28.6	ns
				$V_{DD} = 5\text{ V}$		18	23.4	
t_{PHL1}	Propagation delay time, CLK-OUTn, LE\DM1 = H, OE\DM2 = L			$V_{DD} = 3.3\text{ V}$		9	11.7	ns
				$V_{DD} = 5\text{ V}$		5	6.5	
t_{PHL2}	Propagation delay time, LE\DM1 -OUTn, OE\DM2 = L	$V_{DD} = 3.3\text{ V}$		4	5.2	ns		
		$V_{DD} = 5\text{ V}$		3	3.9			
t_{PHL3}	Propagation delay time, OE\DM2-OUTn, LE\DM1 = H	$V_{DD} = 3.3\text{ V}$		6	7.8	ns		
		$V_{DD} = 5\text{ V}$		3	3.9			
t_{PHL}	Propagation delay time, CLK-SDO	$V_{DD} = 3.3\text{ V}$		25	32.5	ns		
		$V_{DD} = 5\text{ V}$		20	26			
t_{ON}	Output rise time 10~90% of voltage waveform	$V_{DD} = 3.3\text{ V}$		30	39	ns		
		$V_{DD} = 5\text{ V}$		15	19.5			
t_{OFF}	Output fall time 90~10% of voltage waveform	$V_{DD} = 3.3\text{ V}$		7	9.1	ns		
		$V_{DD} = 5\text{ V}$		6	7.8			
t_r	CLK rise time ⁽¹⁾					5000	ns	
t_f	CLK fall time ⁽¹⁾					5000	ns	

1. In order to achieve high cascade data transfer, please consider t_r/t_f timings carefully.

6 Equivalent circuit and outputs

Figure 3. OE/DM2 terminal

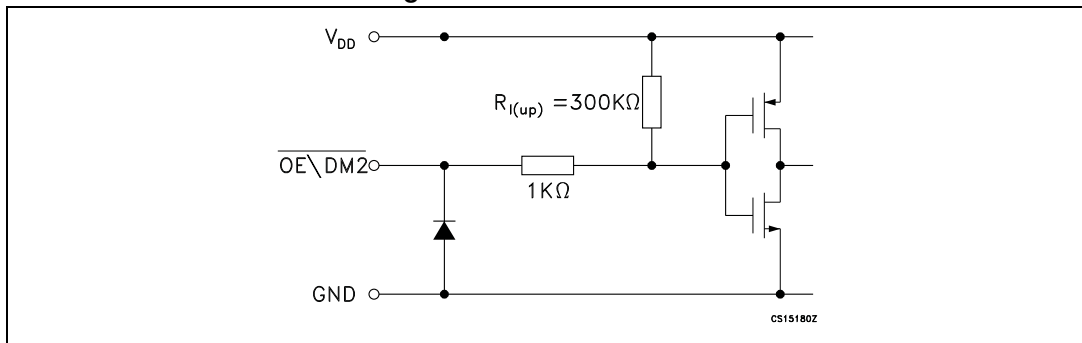

Figure 4. LE/DM1 terminal

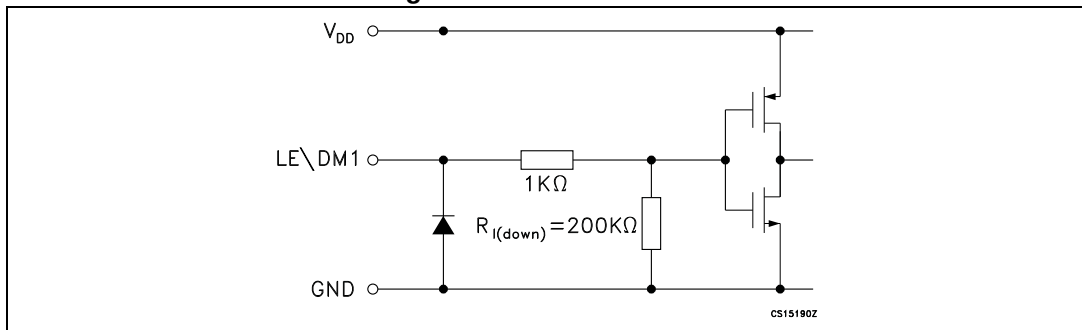

Figure 5. CLK, SDI terminal

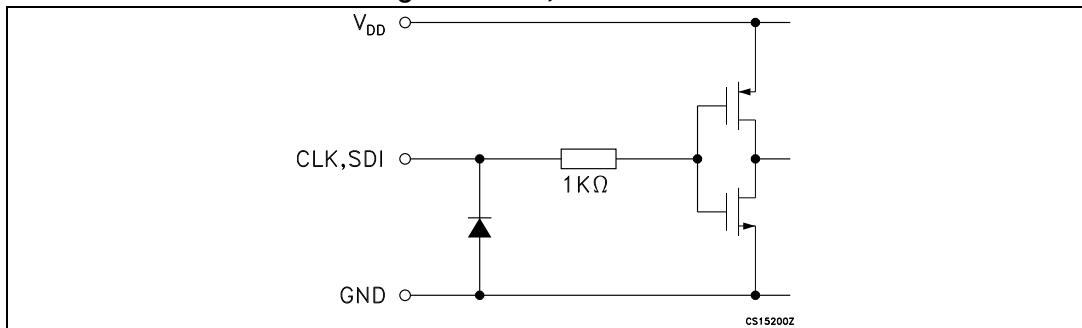
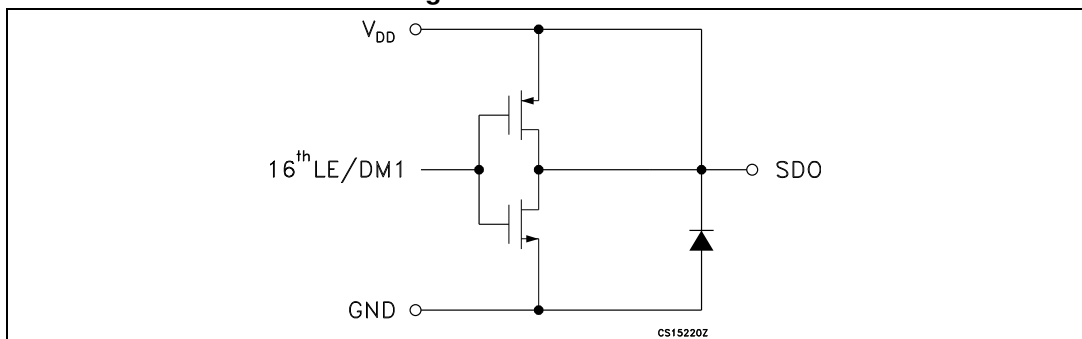

Figure 6. SDO terminal



7 Truth table and timing diagram

7.1 Truth table

Table 9. Truth table

Clock	$\overline{\text{LE}}/\text{DM1}$	$\overline{\text{OE}}/\text{DM2}$	SDI	$\overline{\text{OUT0}}$ $\overline{\text{OUT0}}$ $\overline{\text{OUT7}}$	SDO
	H	L	Dn	Dn Dn -5 Dn -7	Dn -7
	L	L	Dn + 1	No change	Dn -7
	H	L	Dn + 2	$\overline{\text{Dn} + 2}$ $\overline{\text{Dn} - 3}$ $\overline{\text{Dn} - 5}$	Dn -5
	X	L	Dn + 3	$\overline{\text{Dn} + 2}$ $\overline{\text{Dn} - 3}$ $\overline{\text{Dn} - 5}$	Dn -5
	X	H	Dn + 3	OFF	Dn -5

Note: OUT0 to OUT7 = ON when $Dn = H$; OUT0 to OUT7 = OFF when $Dn = L$.

7.2 Timing diagram

Figure 7. Timing diagram - normal mode

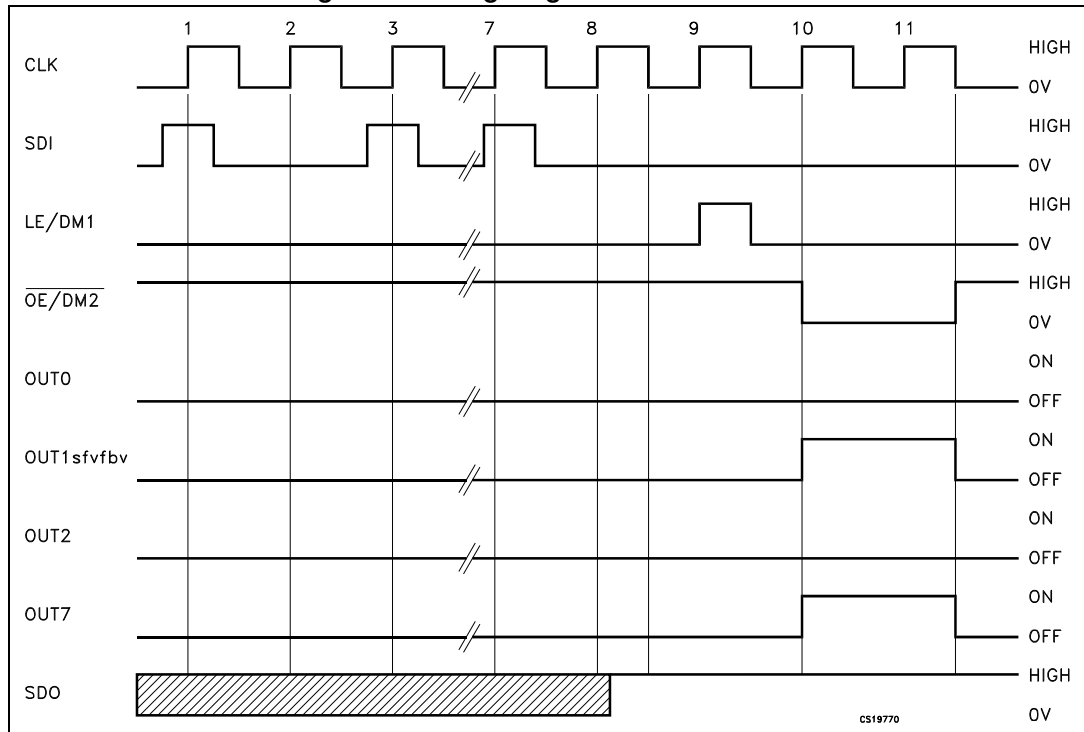

Figure 8. Clock, serial-in, serial-out

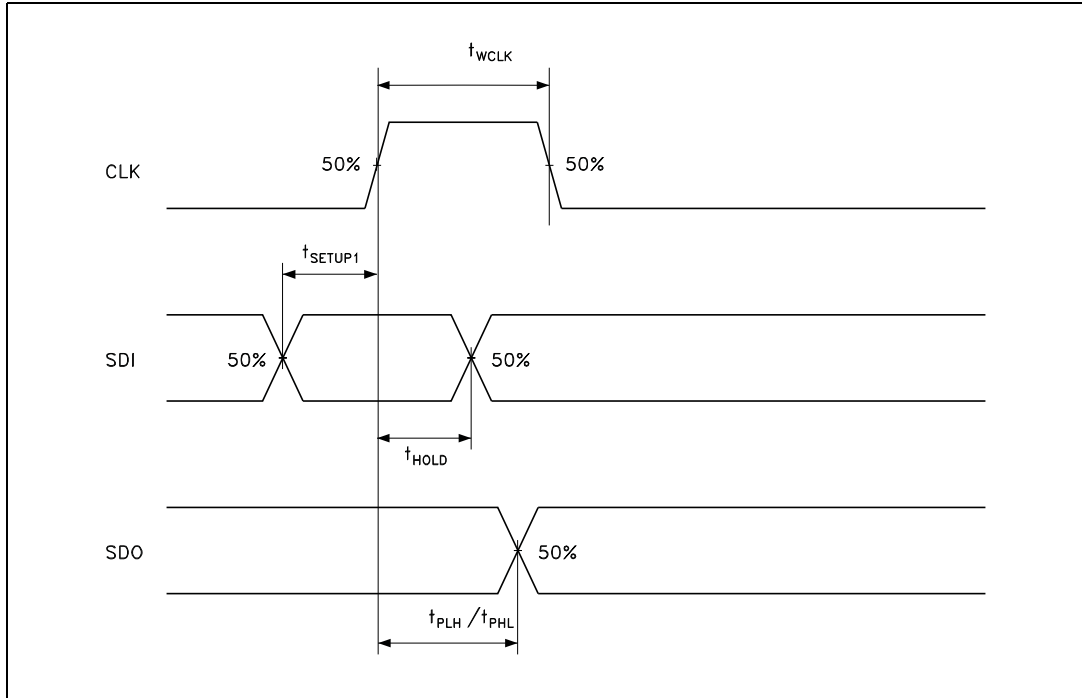

Figure 9. Clock, serial-in, latch, enable, outputs

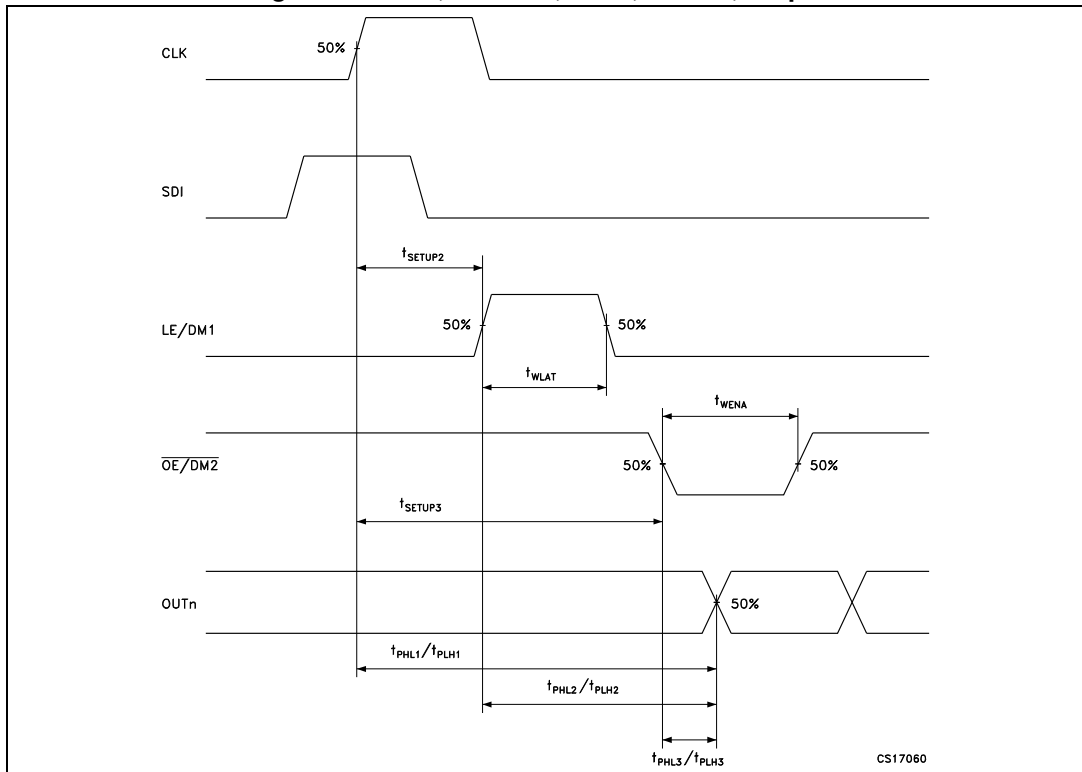
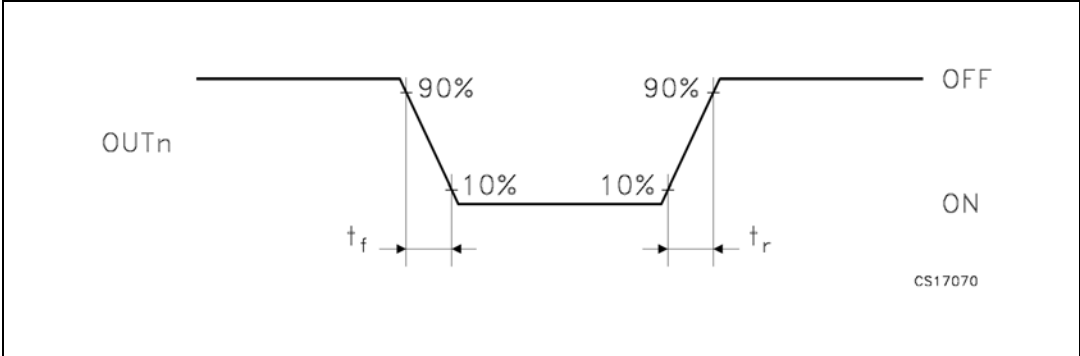

Figure 10. Outputs



8 Typical characteristics

Figure 11. Output current- R_{EXT} resistor

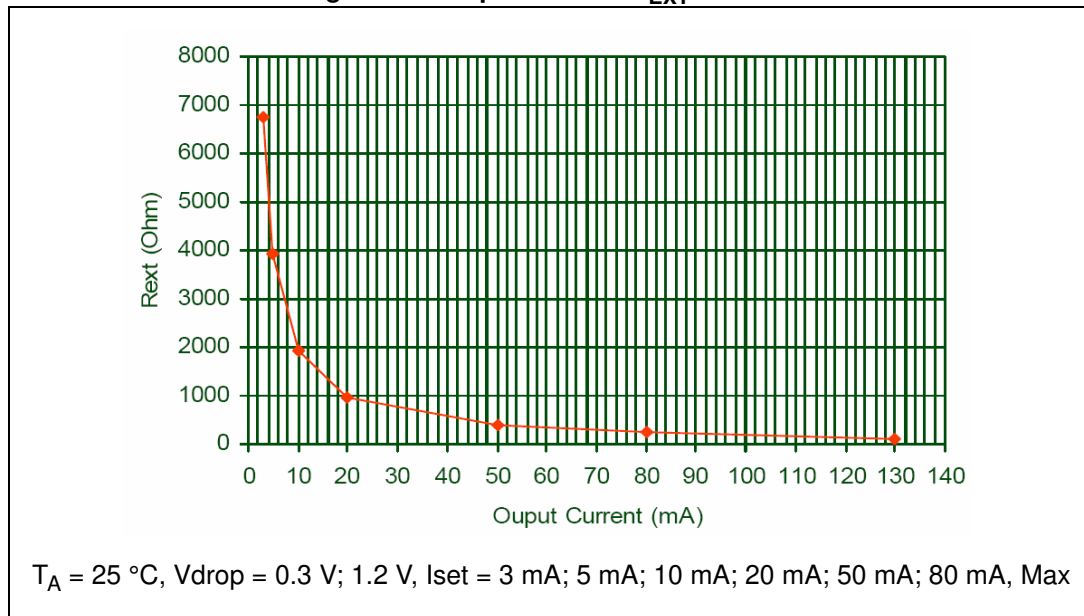

Table 10. Output current- R_{EXT} resistor

Output current (mA)	3	5	10	20	50	80	130
$R_{ext} (\Omega)$	6740	3930	1913	963	386	241	124

Note: Maximum output current capabilities setting was 130 mA applying a $R_{ext} = 124\ \Omega$

Figure 12. I_{SET} vs drop out voltage (V_{DROP})

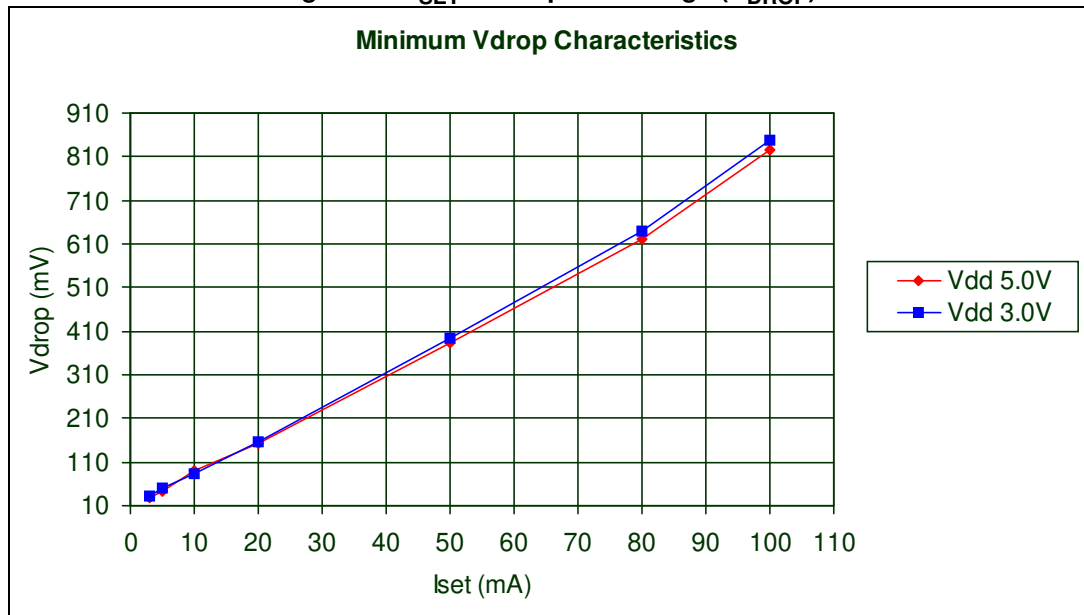
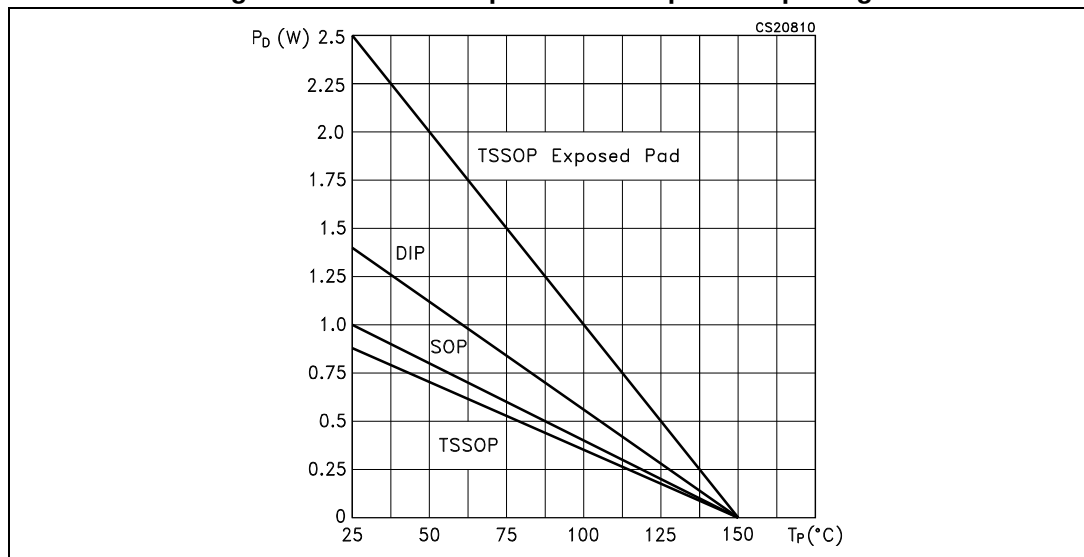

Table 11. I_{SET} vs. drop out voltage (V_{DROP})

Vdd (V)	I set (mA)	Rext (Ω)	Vdrop min (mV)	Vdrop max (mV)	Vdrop AVG (mV)
3	3	6470	30.6	31.2	30.93
	5	3930	46.5	52.9	48.63
	10	1910	80.9	100	82.26
	20	963	150	161	157
	50	386	392	396	394.3
	80	241	636	646	640.3
	100	192	846	850	848
5	3	6470	25.6	29	26.96
	5	3930	40.8	41.7	41.16
	10	1910	80.1	105	89.2
	20	963	153	154	154
	50	386	379	386	382
	80	241	618	626	621
	100	192	825	830	827

Figure 13. Power dissipation vs. temperature package



Note: The exposed-pad should be soldered to the PBC to realize the thermal benefits.

9 Test circuit

Figure 14. DC characteristics

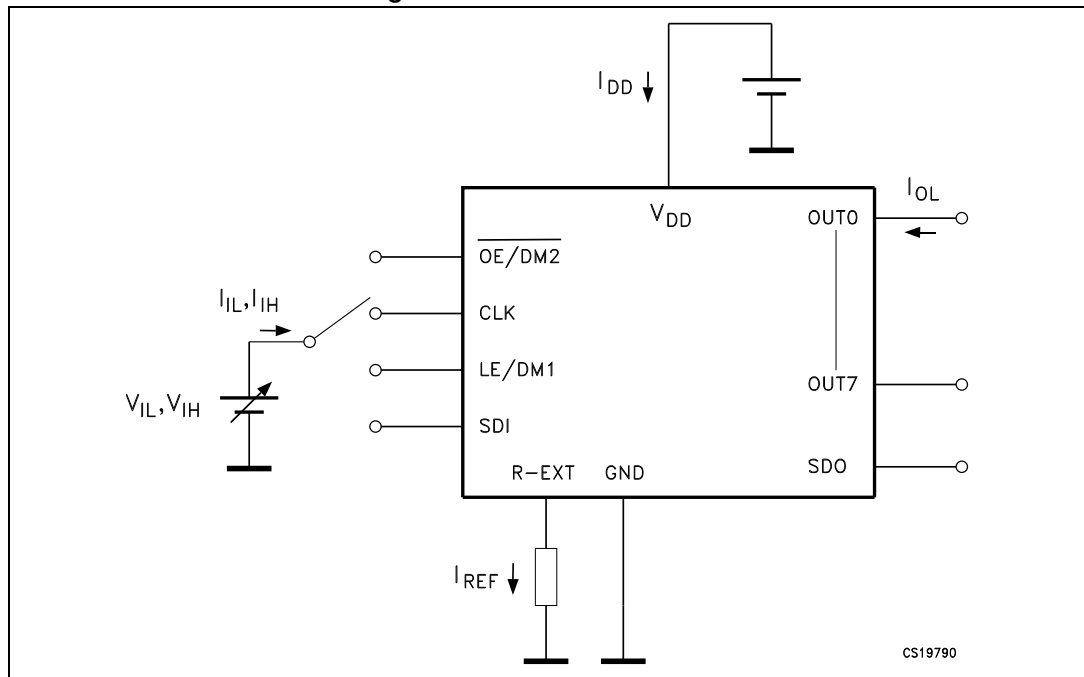

Figure 15. AC characteristics

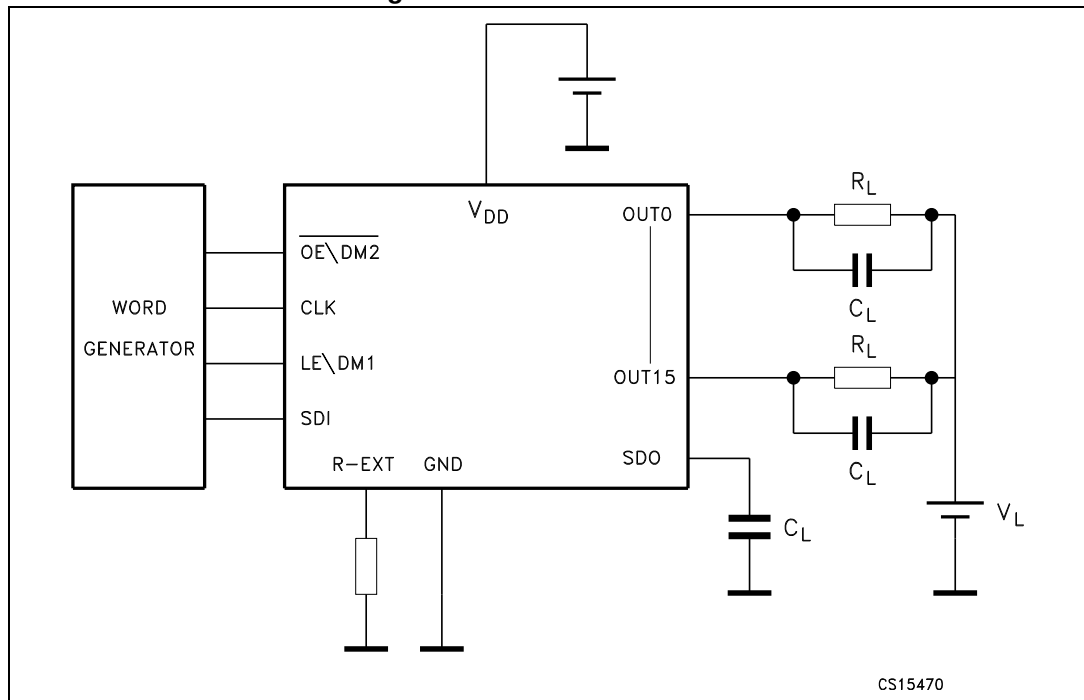
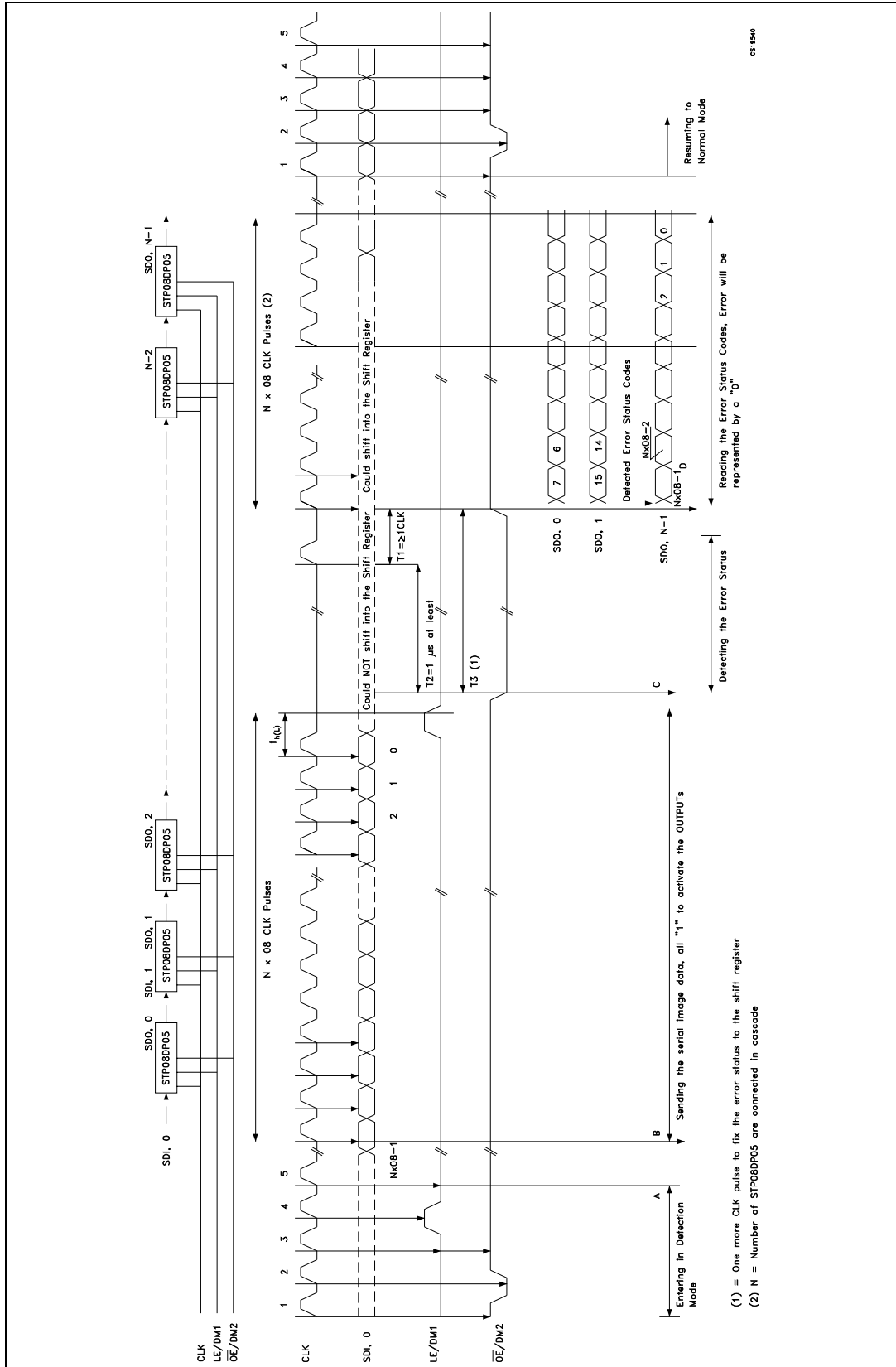

Figure 16. Timing example for open and/or short detection



10 Detection mode functionality

10.1 Phase one: “entering in detection mode“

From the “normal mode” condition the device can switch to the “error mode” by a logic sequence on the OE/DM2 and LE/DM1 pins as showed in the following table and diagram:

Table 12. Entering in detection truth table

CLK	1°	2°	3°	4°	5°
OE/DM2	H	L	H	H	H
LE/DM1	L	L	L	H	L

Figure 17. Entering in detection timing diagram

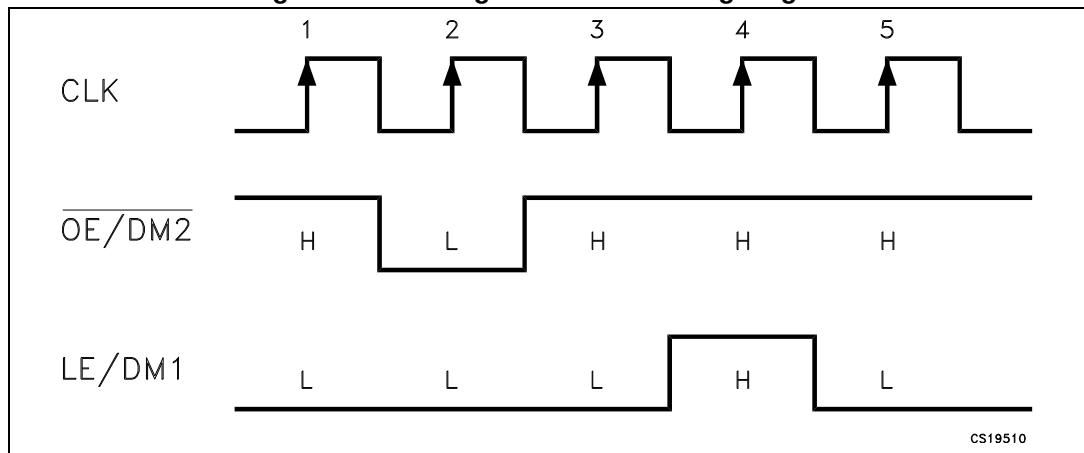

After these five CLK cycles the device goes into the “error detection mode” and at the 6th rise front of CLK the SDI data are ready for the sampling.

10.2 Phase two: “error detection“

The eight data bits must be set “1” in order to set ON all the outputs during the detection. The data are latched by LE/DM1 and after that the outputs are ready for the detection process. When the micro controller switches the OE/DM2 to LOW, the device drives the LEDs in order to analyze if an OPEN or SHORT condition has occurred.

Figure 18. Detection diagram

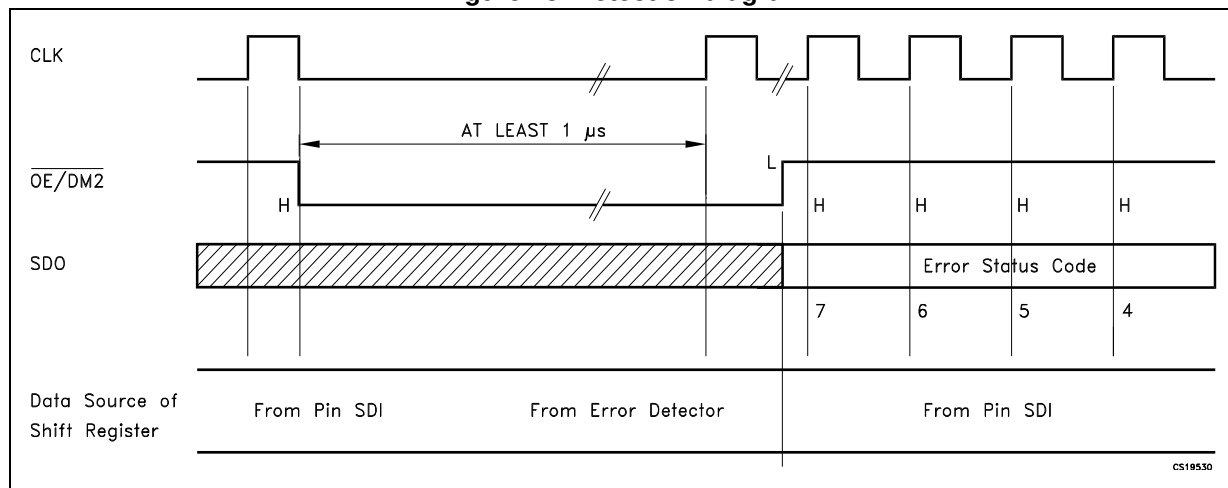

The LEDs status will be detected at least in 1 microsecond and after this time the microcontroller sets $\overline{OE/DM2}$ in HIGH state and the output data detection result will go to the microprocessor via SDO.

Detection mode and normal mode use both the same format data. As soon as all the detection data bits are available on the serial line, the device may go back to normal mode of operation. To re-detect the status the device must go back in normal mode and re-entering in error detection mode.

10.3 Phase three: “resuming to normal mode”

The sequence for re-entering in normal mode is showed in the following table and diagram:

Table 13. Resuming to normal mode timing diagram

CLK	1°	2°	3°	4°	5°
$\overline{\text{OE/DM2}}$	H	L	H	H	H
$\overline{\text{LE/DM1}}$	L	L	L	L	L

Figure 19. Resuming to normal mode timing diagram

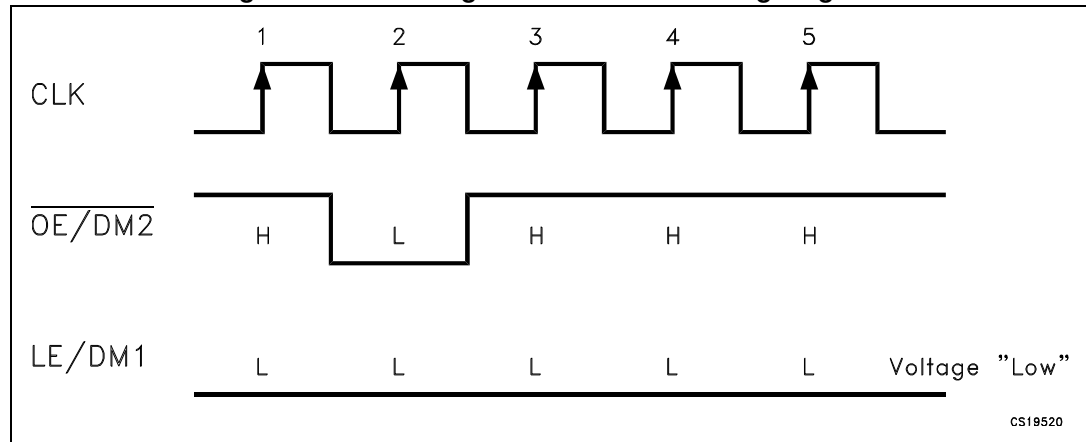

Note: For proper device operation the “entering in detection” sequence must follow by a “resume mode” sequence, isn’t possible to insert consecutive equal sequence.

10.4 Error detection conditions

$V_{DD} = 3.3$ to 5 V temperature range 25 °C.

Table 14. Detection condition

SW-1 or SW-3b	Open line or output short to GND detected	$\implies I_{ODEC} \leq 0.5 \times I_O$	No error detected	$\implies I_{ODEC} \geq 0.5 \times I_O$
SW-2 or SW-3a	Short on LED or short to V-LED detected	$\implies V_O \geq 2.5V$	No error detected	$\implies V_O \leq 2.2 V$

Note: Where: I_O = the output current programmed by the R_{EXT} ,
 I_{ODEC} = the detected output current in detection mode.

Figure 20. Detection circuit

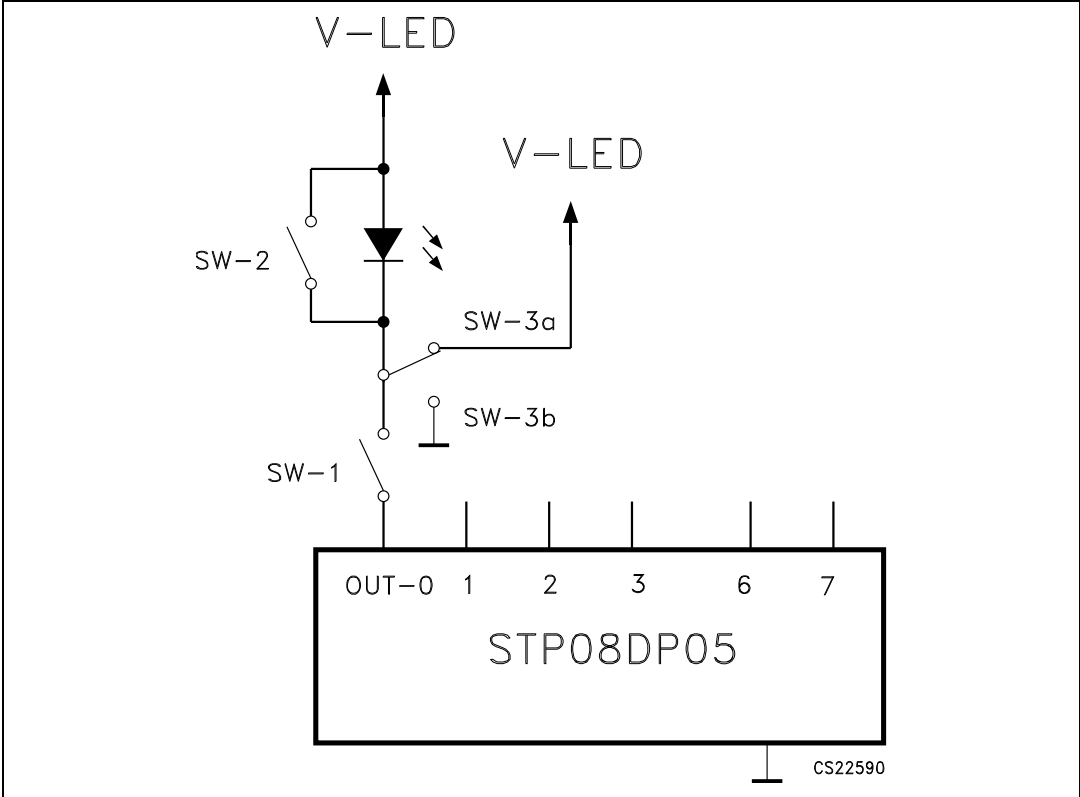

11 Package mechanical data

In order to meet environmental requirements, ST offers these devices in different grades of ECOPACK[®] packages, depending on their level of environmental compliance. ECOPACK[®] specifications, grade definitions and product status are available at: www.st.com. ECOPACK[®] is an ST trademark.

Table 15. DIP16 mechanical data

Dim.	mm		
	Min.	Typ.	Max.
a1	0.51		
B	0.77		1.65
b		0.5	
b1		0.25	
D			20
E		8.5	
e		2.54	
e3		17.78	
F			7.1
l			5.1
L		3.3	
Z			1.27

Figure 21. DIP16 drawing

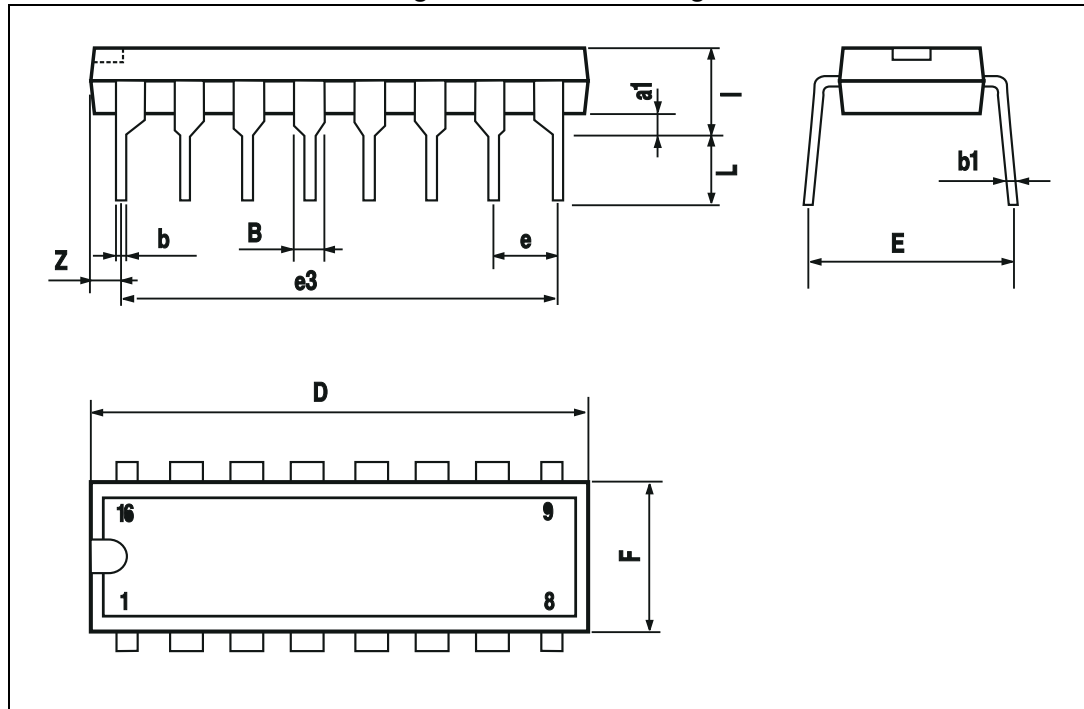

Table 16. HTSSOP16 exposed pad mechanical data

Dim.	mm		
	Min.	Typ.	Max.
A			1.20
A1			0.15
A2	0.80	1.00	1.05
b	0.19		0.30
c	0.09		0.20
D	4.90	5.00	5.10
D1		3.00	
E	6.20	6.40	6.60
E1	4.30	4.40	4.50
E2		3.00	
e		0.65	
L	0.45	0.60	0.75
L1		1.00	
k	0.00		8.00
aaa			0.10

Figure 22. HTSSOP16 exposed pad drawing

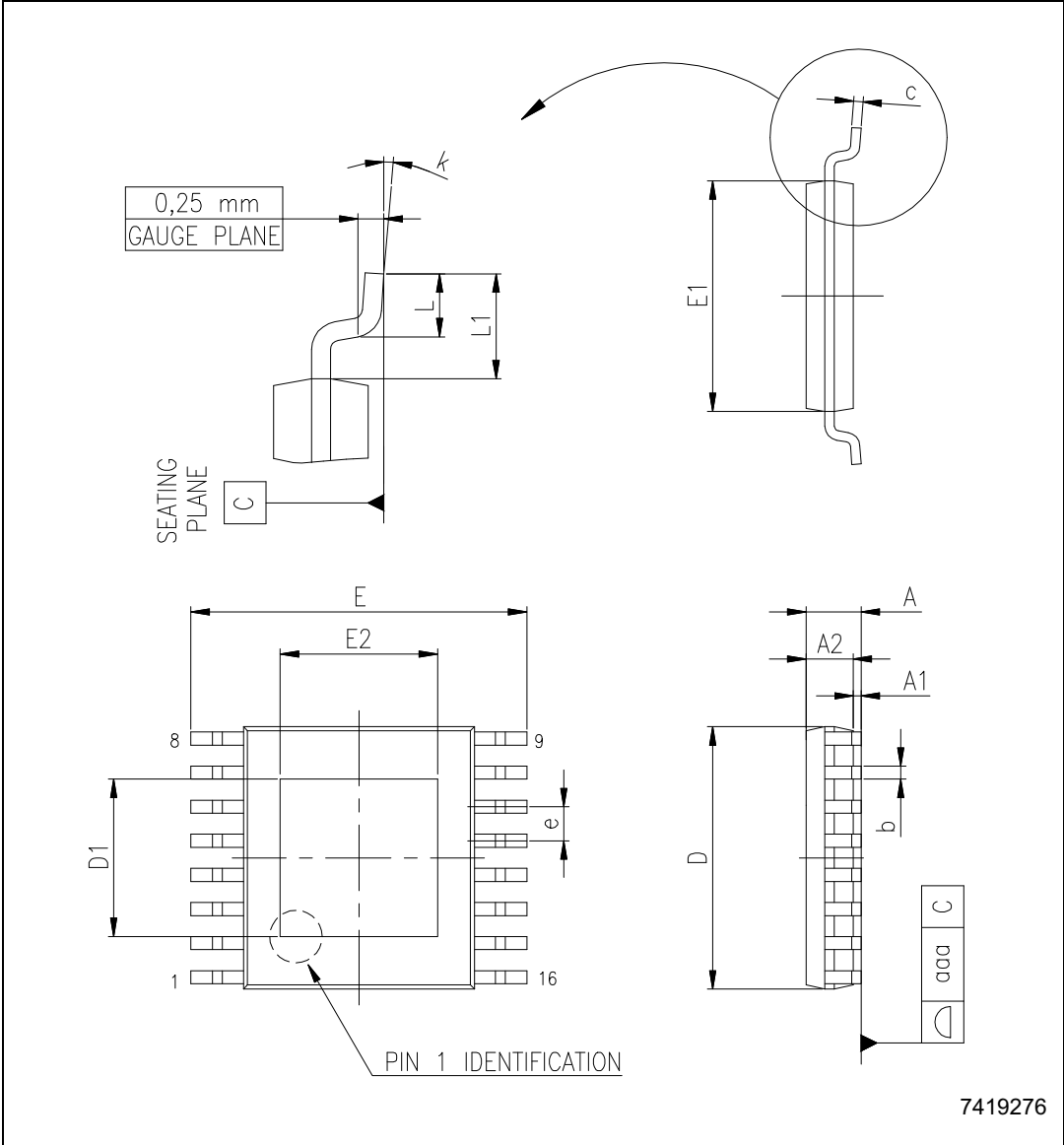
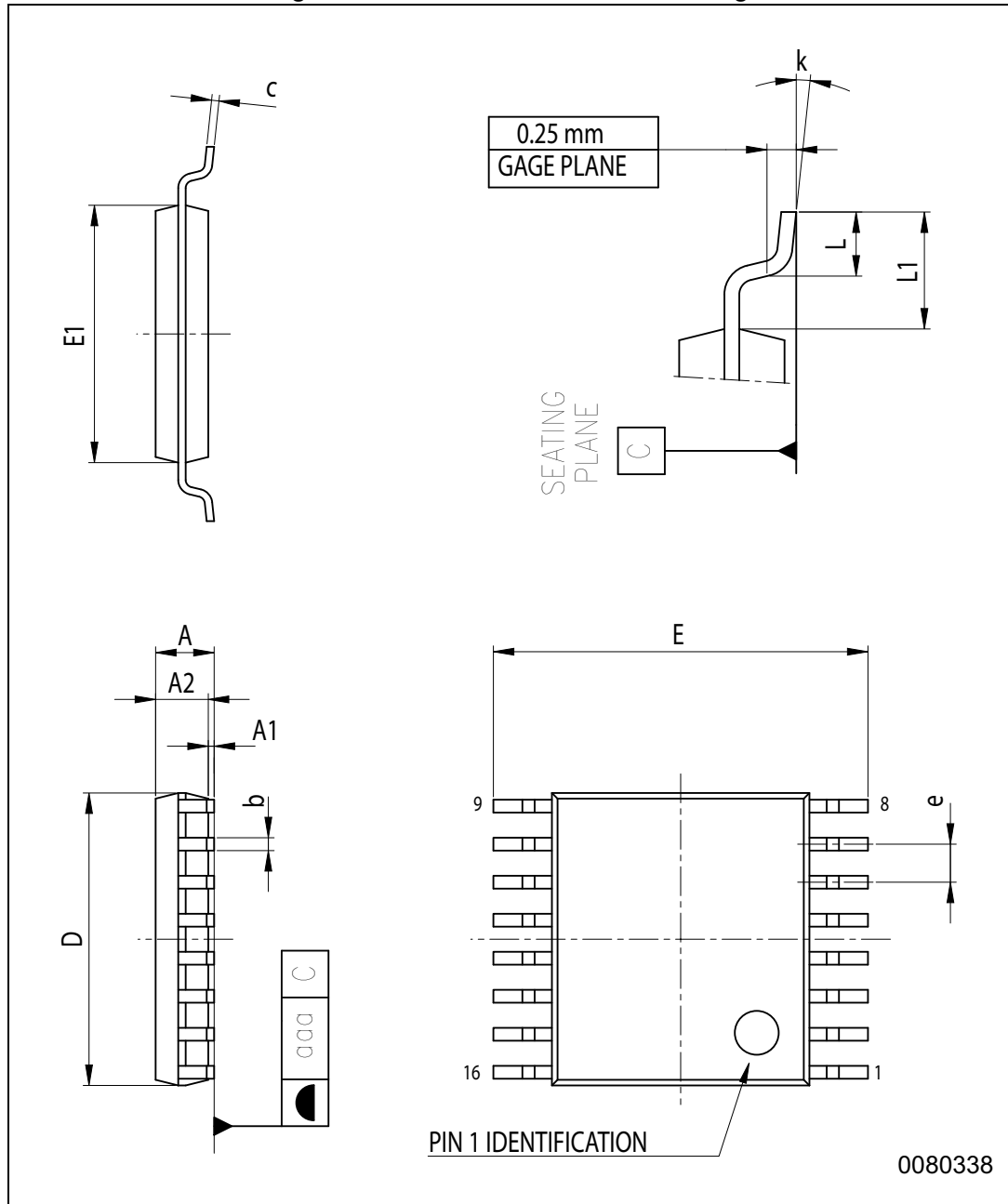

Table 17. TSSOP16 mechanical data

Dim.	mm		
	Min.	Typ.	Max.
A			1.20
A1	0.05		0.15
A2	0.80	1.00	1.05
b	0.19		0.30
c	0.09		0.20
D	4.90	5.00	5.10
E	6.20	6.40	6.60
E1	4.30	4.40	4.50
e		0.65	
L	0.45	0.60	0.75
L1		1.00	
k	0		8
aaa			0.10

Figure 23. TSSOP16 mechanical drawing



0080338

Table 18. SO16 dimensions

Dim.	mm		
	Min.	Typ.	Max.
A			1.75
A1	0.10		0.25
A2	1.25		
b	0.31		0.51
c	0.17		0.25
D	9.80	9.90	10.00
E	5.80	6.00	6.20
E1	3.80	3.90	4.00
e		1.27	
h	0.25		0.50
L	0.40		1.27
k	0		8°
ccc			0.10

Figure 24. Package drawing

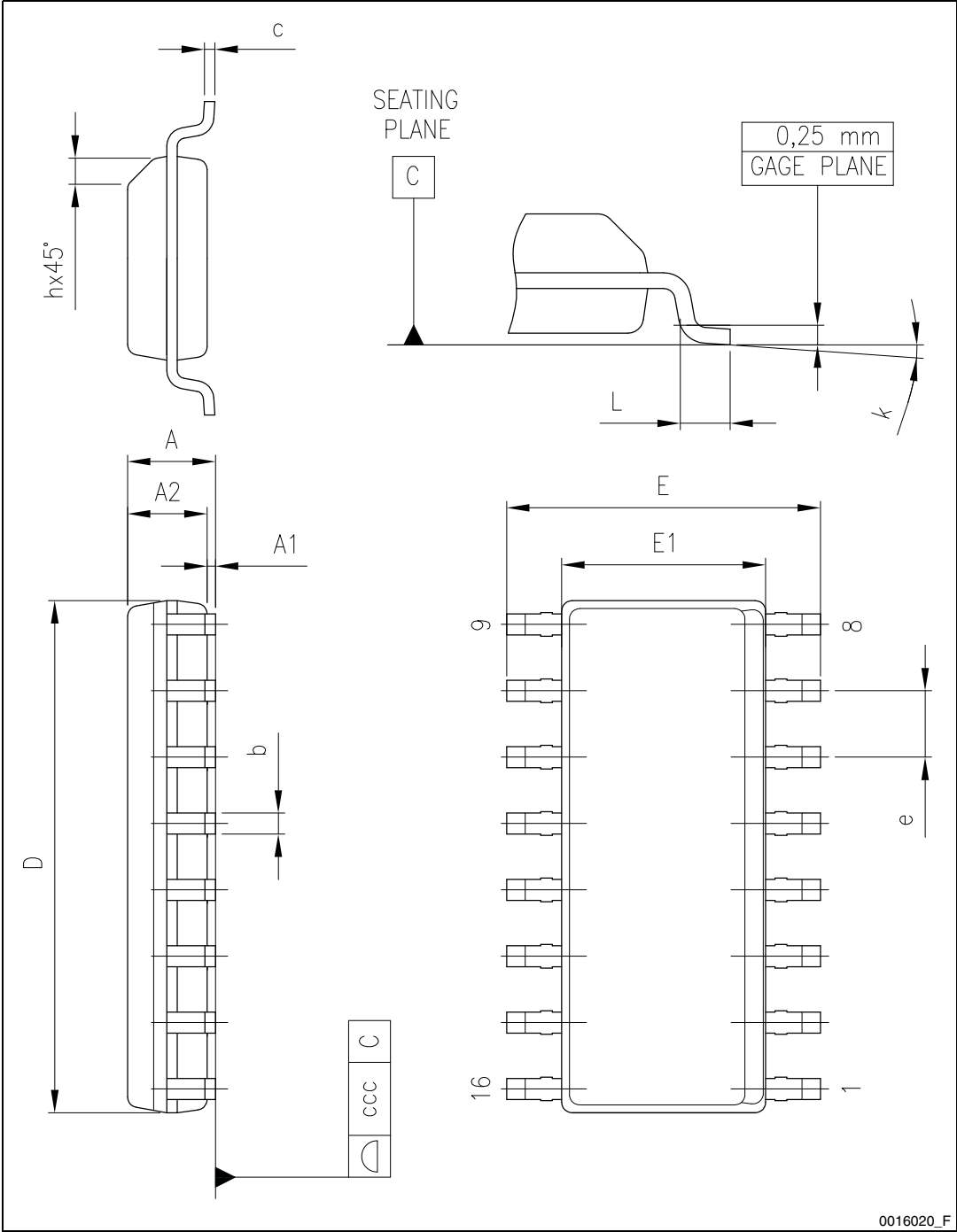

0016020_F



Figure 25. Recommended footprint (dimensions are in mm)

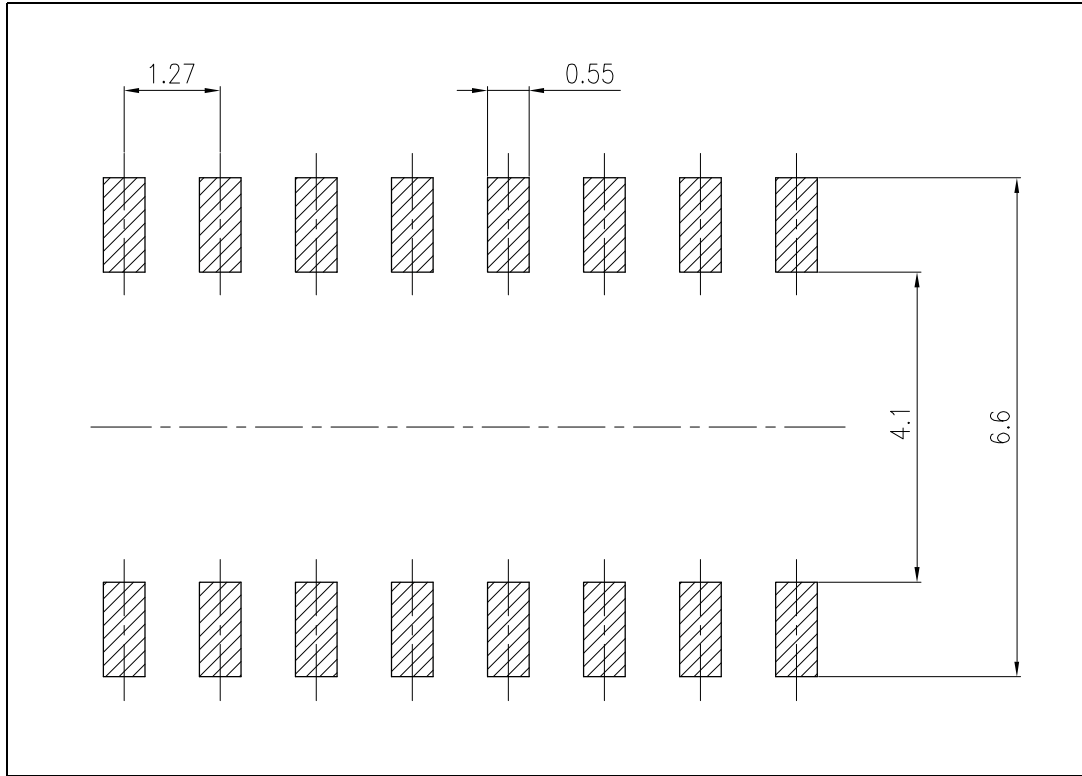

12 Packaging mechanical data

Table 19. HTSSOP16 EP and TSSOP16 tape and reel mechanical data

Dim.	(mm)		
	Min.	Typ.	Max.
A			330
C	12.8		13.2
D	20.2		
N	60		
T			22.4
Ao	6.7		6.9
Bo	5.3		5.5
Ko	1.6		1.8
Po	3.9		4.1
P	7.9		8.1

Figure 26. Tape and reel for HTSSOP16 EP and TSSOP16

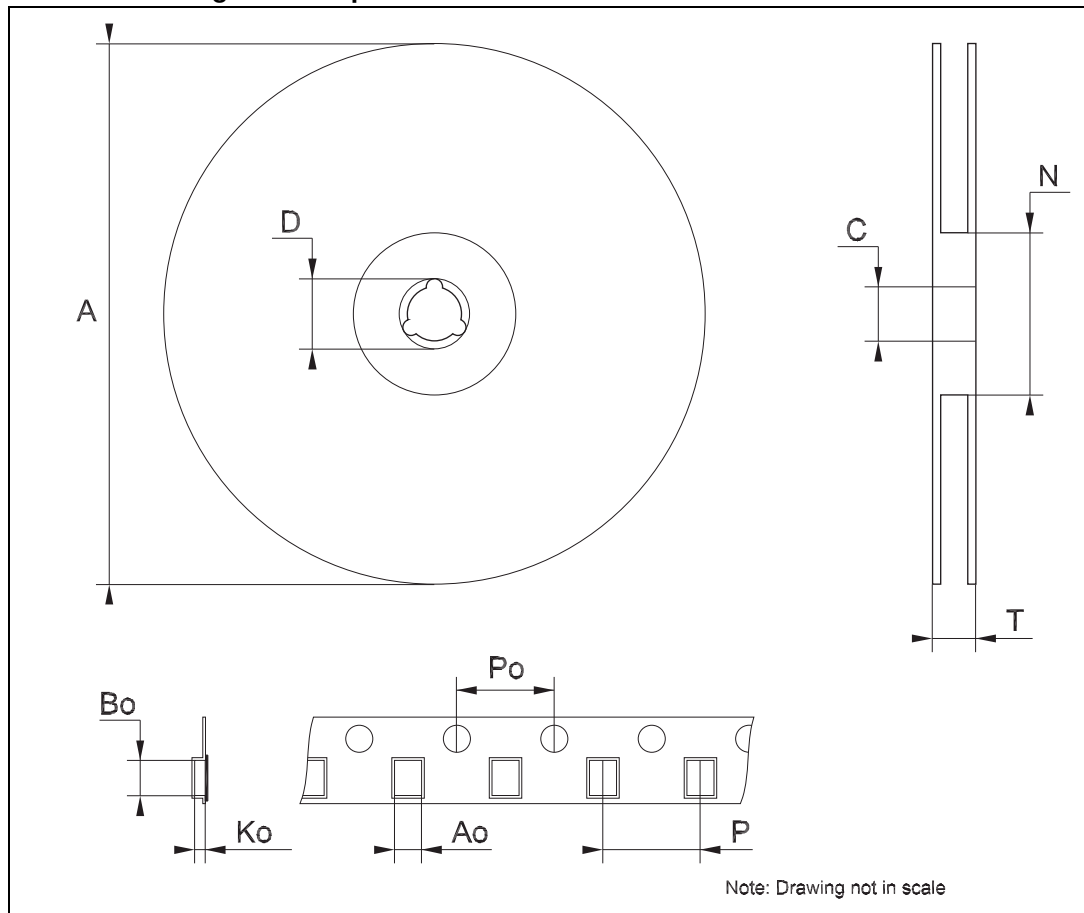

13 Revision history

Table 20. Document revision history

Date	Revision	Changes
3-Apr-2007	1	First release
21-May-2007	2	Updated Table 7 on page 8
08-Aug-2008	3	Updated Section 8: Typical characteristics on page 14 added Figure 13 and Figure 11 on page 15 updated Figure 14 on page 16.
22-Oct-2009	4	Updated Note: on page 3.
29-Jul-2013	5	Updated Section 11: Package mechanical data, Figure 4: OE/DM2 terminal and Figure 5: LE/DM1 terminal. Added Section 12: Packaging mechanical data.
28-Jun-2018	6	Updated Table 16: HTSSOP16 exposed pad mechanical data and Figure 22: HTSSOP16 exposed pad drawing .

IMPORTANT NOTICE – PLEASE READ CAREFULLY

STMicroelectronics NV and its subsidiaries ("ST") reserve the right to make changes, corrections, enhancements, modifications, and improvements to ST products and/or to this document at any time without notice. Purchasers should obtain the latest relevant information on ST products before placing orders. ST products are sold pursuant to ST's terms and conditions of sale in place at the time of order acknowledgement.

Purchasers are solely responsible for the choice, selection, and use of ST products and ST assumes no liability for application assistance or the design of Purchasers' products.

No license, express or implied, to any intellectual property right is granted by ST herein.

Resale of ST products with provisions different from the information set forth herein shall void any warranty granted by ST for such product.

ST and the ST logo are trademarks of ST. All other product or service names are the property of their respective owners.

Information in this document supersedes and replaces information previously supplied in any prior versions of this document.

© 2018 STMicroelectronics – All rights reserved