

REVISONS		DATE	BY	APP'D
NO	DESCRIPTION			
1	REV PER ECO-15-016062	10NOV15	KG	CD

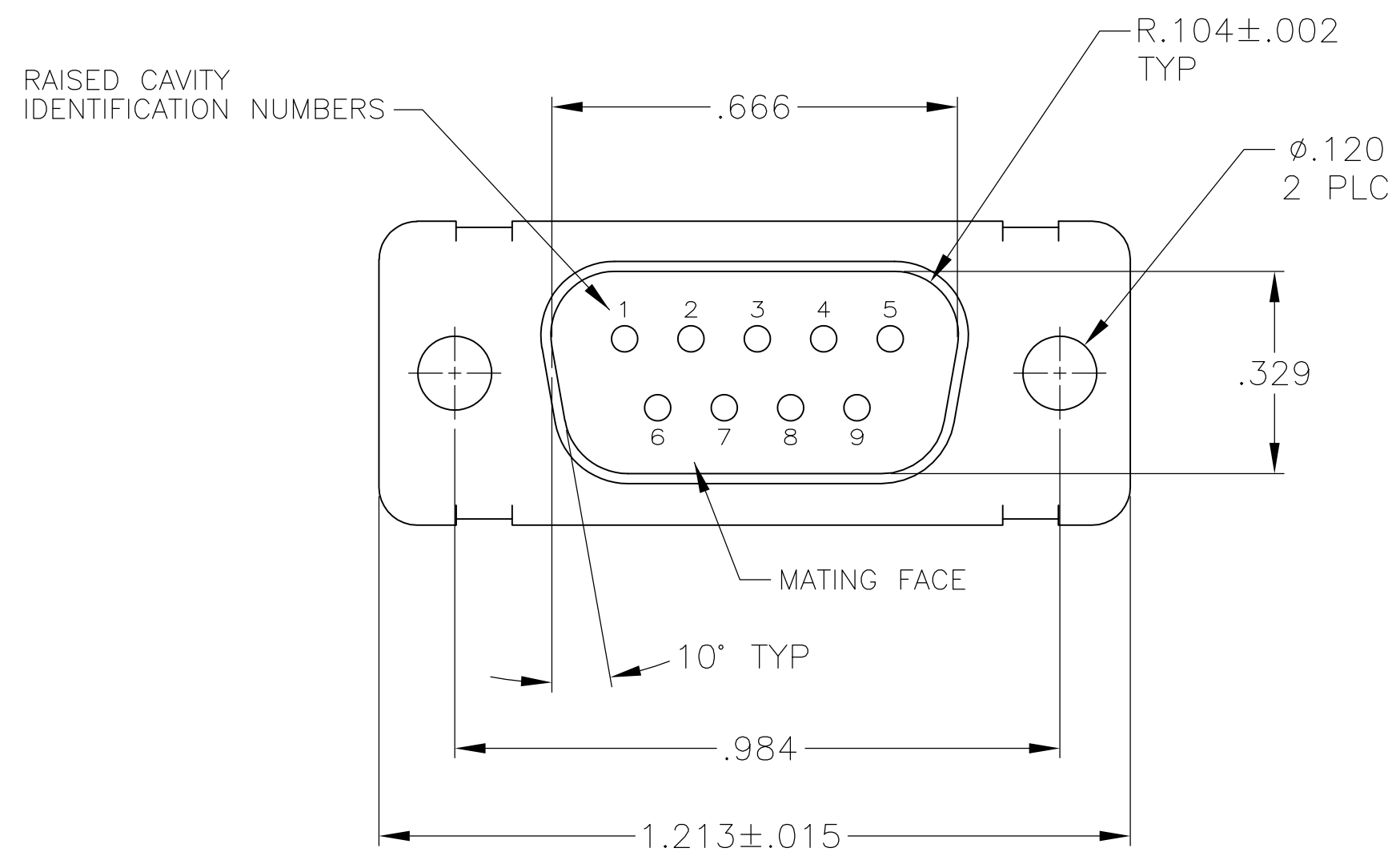

- 1 THIS PLUG IS DESIGNED TO CONFORM TO THE LATEST ISSUE OF MIL-C-24308.
- 2. MAX WIRE INSULATION TO BE USED WITH THIS PLUG IS .072 DIA.
- 3. METAL RETENTION CLIPS ARE INCLUDED IN INSERTS.
- 4. THIS PLUG WILL ACCEPT SIZE 20 CRIMP TYPE PIN CONTACT M 39029/64-369 (TE CONNECTIVITY P/N 205089-1) FOR ALTERNATE CONTACT OPTIONS CONSULT TE CONNECTIVITY CATALOG.
- 5 PART NO. 205162-4, 205162-5 & 5-205162-4 HAS GROUNDING INDENTS ON FRONT SHELL. (NOT SHOWN)
- 6 FINISH: CADMIUM PER QQ-P-416, TYPE II, CLASS 2 OVER COPPER PER AMS2418, CLASS 4.
- 8 THIS NOTE APPLIES TO 205162-1 ONLY. M24308/4-1F MARKED ON FAR SIDE. 205556-2 MARKED ON NEAR SIDE. MFG'S PART NO. & MILITARY PART NO. MARKED ON CONNECTOR REPRESENTS KIT NUMBER WITH CONTACTS PACKAGE STAMPED M 24308/4-259F
- 9 CONTACTS ARE NOT INCLUDED IN THIS ASSEMBLY. MUST BE ORDERED SEPARATELY.
- 10 FINISH: BRIGHT TIN .000400-.000550 THK PER ASTM-B-545 OVER COPPER .000050 MIN THK PER AMS2418.

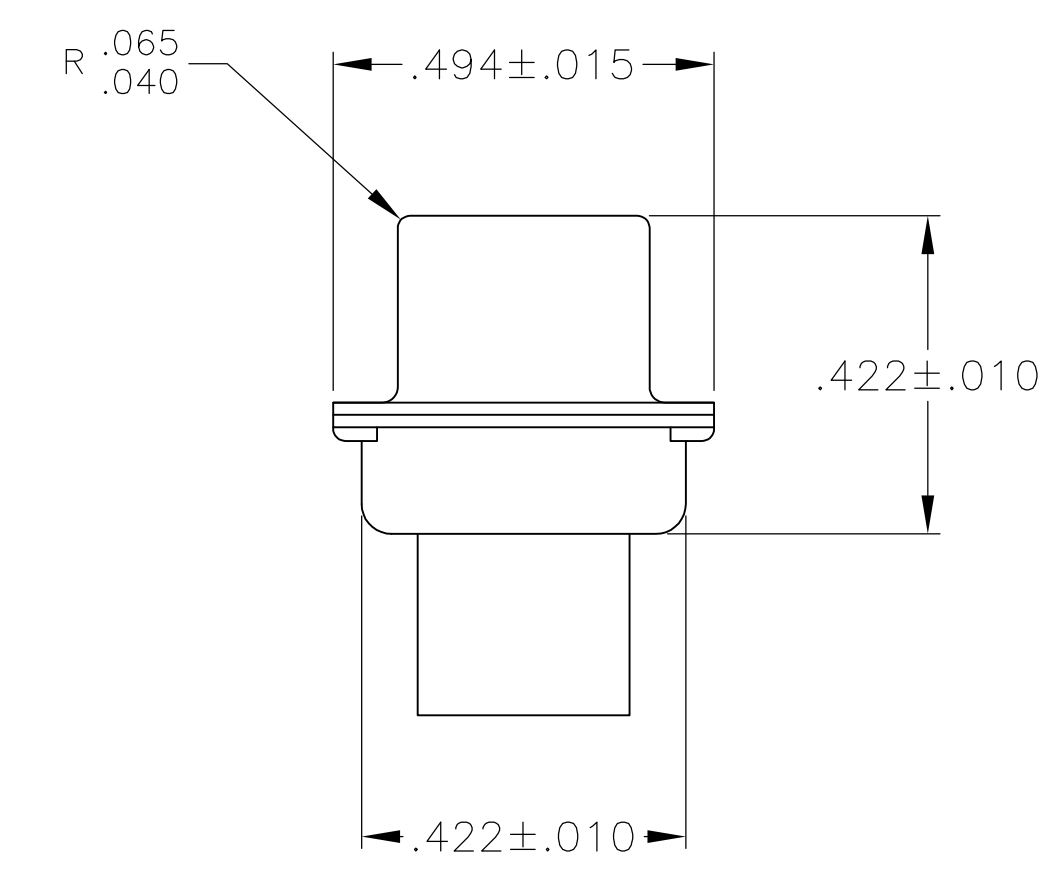
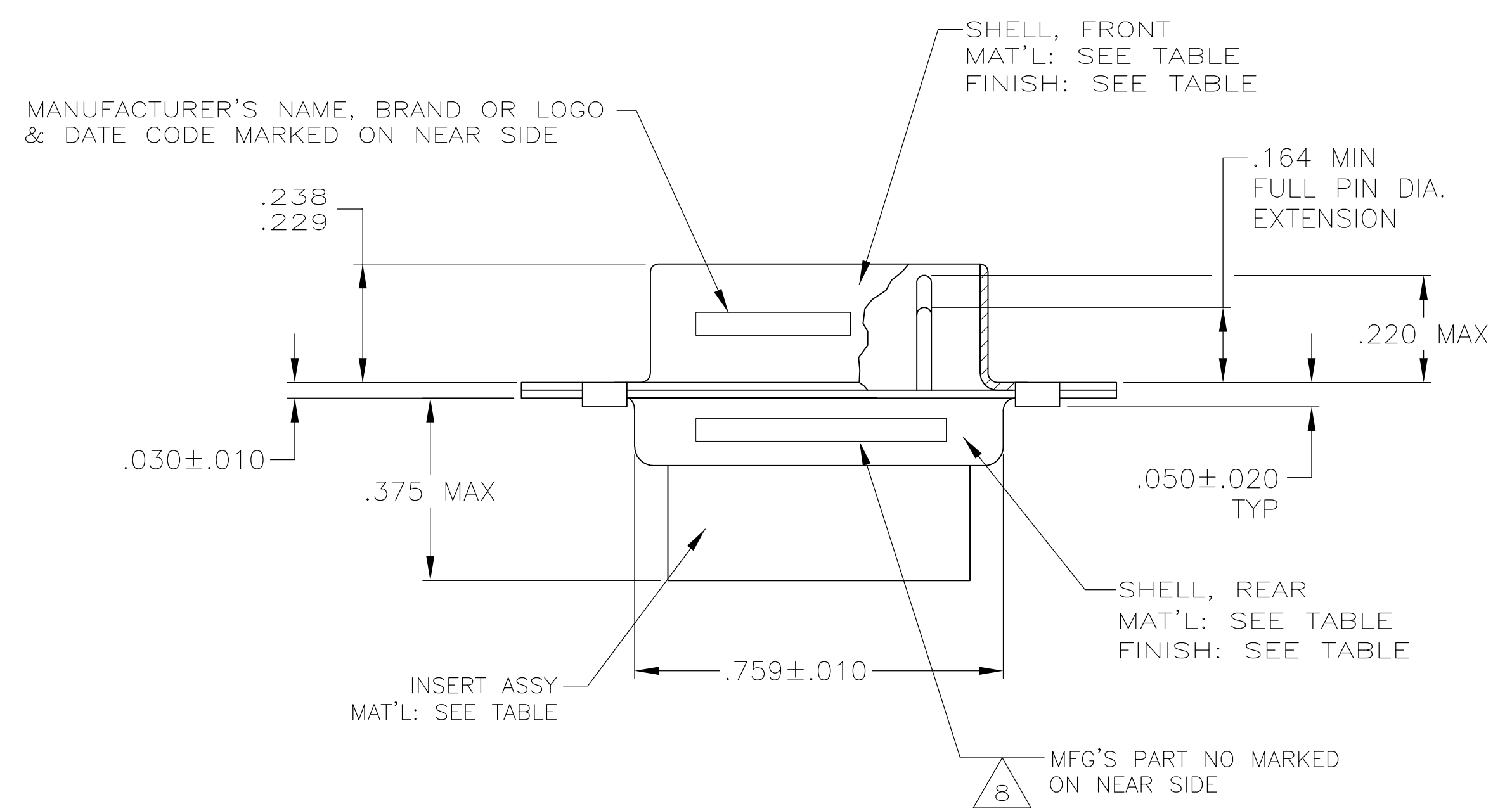

5 11	10	STEEL PER ASTM-A-109 OR EQUIVALENT	POLYESTER PER MIL-M-24519, TYPE GET-30F	5-205162-4
9	10	STEEL PER ASTM-A-109 OR EQUIVALENT	POLYESTER PER MIL-M-24519, TYPE GET-30F	205162-6
5 9	10	STEEL PER ASTM-A-109 OR EQUIVALENT	POLYESTER PER MIL-M-24519, TYPE GET-30F	205162-5
5 9	10	STEEL PER ASTM-A-109 OR EQUIVALENT	POLYESTER PER MIL-M-24519, TYPE GET-30F	205162-4
SUPSD BY 206288-1 9	6	STEEL PER ASTM-A-109 OR EQUIVALENT	POLYESTER PER MIL-M-24519, TYPE GET-30F	205162-3
SUPSD BY 207252-2	6	STEEL PER ASTM-A-109 OR EQUIVALENT	POLYESTER PER MIL-M-24519, TYPE GET-30F	205162-2
1 8 9	6	STEEL PER ASTM-A-109 OR EQUIVALENT	POLYESTER PER MIL-M-24519, TYPE GET-30F	205162-1
REMARKS	SHELL FINISH	SHELL MATERIAL	INSERT MAT'L	PART NUMBER

THIS DRAWING IS A CONTROLLED DOCUMENT.

DIMENSIONS: INCHES
 TOLERANCES UNLESS OTHERWISE SPECIFIED:
 0 PLC ± -
 1 PLC ± -
 2 PLC ± -
 3 PLC ± .005
 4 PLC ± -
 ANGLES ± 0°30'

MATERIAL: SEE CALLOUTS
 FINISH: SEE CALLOUTS

DWG NO: C.C. THOMAS 2-9-05
 CHK: D. MILLER 2-9-05
 APP'D: D. MILLER 2-9-05
 NAME: PLUG ASSY, AMPLITE, 9 POSN SIZE 1, SERIES 109
 PRODUCT SPEC: MIL-C-24308
 APPLICATION SPEC: I.S. 7516 & 7505
 WEIGHT: -
 CUSTOMER DRAWING: A100779 ©=205162

SCALE: 4:1
 SHEET: 1 OF 1
 REV: V