

# MC74LCX16240

## Low-Voltage CMOS 16-Bit Buffer

### With 5 V-Tolerant Inputs and Outputs (3-State, Inverting)

The MC74LCX16240 is a high performance, inverting 16-bit buffer operating from a 2.3 V to 3.6 V supply. The device is nibble controlled. Each nibble has separate Output Enable inputs which can be tied together for full 16-bit operation. High impedance TTL compatible inputs significantly reduce current loading to input drivers while TTL compatible outputs offer improved switching noise performance. A  $V_I$  specification of 5.5 V allows MC74LCX16240 inputs to be safely driven from 5.0 V devices. The LCX16240 is suitable for memory address driving and all TTL level bus oriented transceiver applications.

Current drive capability is 24 mA at the outputs. The Output Enable ( $\overline{OEn}$ ) inputs, when HIGH, disable the outputs by placing them in a HIGH Z condition.

The MC74LCX16240 contains sixteen inverting buffers with 3-state 5.0 V tolerant outputs. The device is nibble controlled with each nibble functioning identically, but independently. The control pins may be tied together to obtain full 16-bit operation. The 3-state outputs are controlled by an Output Enable ( $\overline{OEn}$ ) input for each nibble. When  $\overline{OEn}$  is LOW, the outputs are on. When  $\overline{OEn}$  is HIGH, the outputs are in the high impedance state.

#### Features

- Designed for 2.3 to 3.6 V  $V_{CC}$  Operation
- 5.0 V Tolerant – Interface Capability With 5.0 V TTL Logic
- Supports Live Insertion and Withdrawal
- $I_{OFF}$  Specification Guarantees High Impedance When  $V_{CC} = 0$  V
- LVTTTL Compatible
- LVCMOS Compatible
- 24 mA Balanced Output Sink and Source Capability
- Near Zero Static Supply Current in All Three Logic States (10  $\mu$ A)  
Substantially Reduces System Power Requirements
- Latchup Performance Exceeds 500 mA
- ESD Performance: Human Body Model >2000 V;  
Machine Model >200 V
- These are Pb-Free Devices\*

\*For additional information on our Pb-Free strategy and soldering details, please download the ON Semiconductor Soldering and Mounting Techniques Reference Manual, SOLDERRM/D.



ON Semiconductor®

<http://onsemi.com>

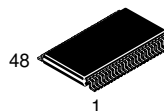

TSSOP-48  
DT SUFFIX  
CASE 1201

#### MARKING DIAGRAM

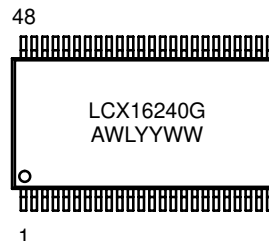

A = Assembly Location  
WL = Wafer Lot  
YY = Year  
WW = Work Week  
G = Pb-Free Package

#### ORDERING INFORMATION

See detailed ordering and shipping information in the package dimensions section on page 3 of this data sheet.

# MC74LCX16240

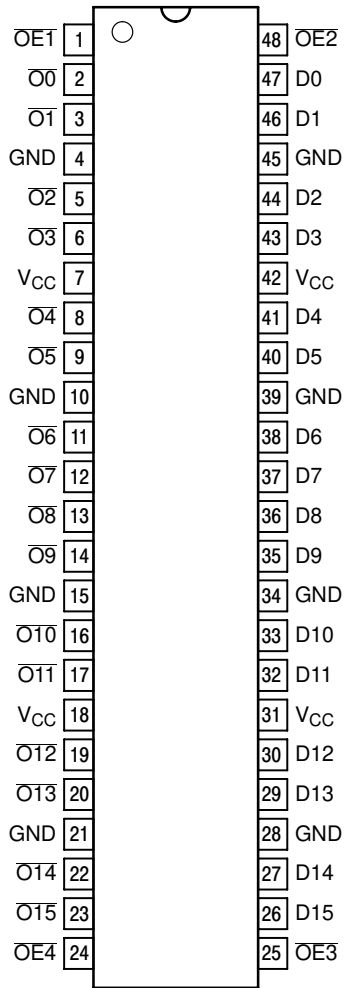

Figure 1. Pinout: TSSOP-48 (Top View)

Table 1. PIN NAMES

Pins	Function
$\overline{OE}n$ D0–D15 O0–O15	Output Enable Inputs Inputs Outputs

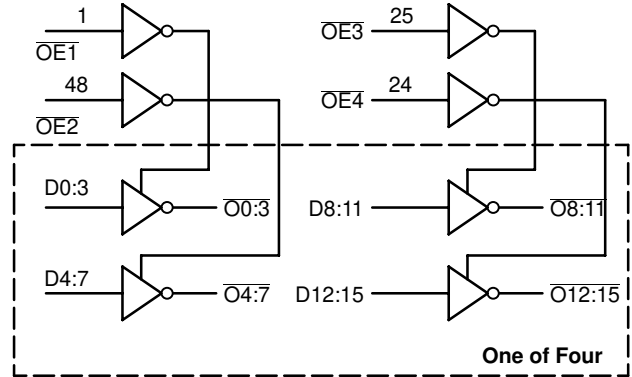

Figure 2. Logic Diagram

## TRUTH TABLE

OE1	D0:3	O0:3	OE2	D4:7	O4:7	OE3	D8:11	O8:11	OE4	D12:15	O12:15
L	L	H	L	L	H	L	L	H	L	L	H
L	H	L	L	H	L	L	H	L	L	H	L
H	X	Z	H	X	Z	H	X	Z	H	X	Z

H = High Voltage Level  
 L = Low Voltage Level  
 Z = High Impedance State  
 X = High or Low Voltage Level and Transitions are Acceptable; for I<sub>CC</sub> reasons, DO NOT FLOAT Inputs

# MC74LCX16240

## ORDERING INFORMATION

Device	Package	Shipping†
MC74LCX16240DTR2	TSSOP–48*	2500 / Tape & Reel
M74LCX16240DTR2G	TSSOP–48*	2500 / Tape & Reel

†For information on tape and reel specifications, including part orientation and tape sizes, please refer to our Tape and Reel Packaging Specifications Brochure, BRD8011/D.

\*This package is inherently Pb–Free.

## MAXIMUM RATINGS

Symbol	Parameter	Value	Condition	Unit
$V_{CC}$	DC Supply Voltage	–0.5 to +7.0		V
$V_I$	DC Input Voltage	$-0.5 \leq V_I \leq +7.0$		V
$V_O$	DC Output Voltage	$-0.5 \leq V_O \leq +7.0$	Output in 3–State	V
		$-0.5 \leq V_O \leq V_{CC} + 0.5$	Output in HIGH or LOW State (Note 1)	V
$I_{IK}$	DC Input Diode Current	–50	$V_I < \text{GND}$	mA
$I_{OK}$	DC Output Diode Current	–50	$V_O < \text{GND}$	mA
		+50	$V_O > V_{CC}$	mA
$I_O$	DC Output Source/Sink Current	$\pm 50$		mA
$I_{CC}$	DC Supply Current Per Supply Pin	$\pm 100$		mA
$I_{GND}$	DC Ground Current Per Ground Pin	$\pm 100$		mA
$T_{STG}$	Storage Temperature Range	–65 to +150		°C

Maximum ratings are those values beyond which device damage can occur. Maximum ratings applied to the device are individual stress limit values (not normal operating conditions) and are not valid simultaneously. If these limits are exceeded, device functional operation is not implied, damage may occur and reliability may be affected.

1.  $I_O$  absolute maximum rating must be observed.

## RECOMMENDED OPERATING CONDITIONS

Symbol	Parameter	Min	Typ	Max	Unit	
$V_{CC}$	Supply Voltage	Operating	2.0	2.5, 3.3	3.6	V
		Data Retention Only	1.5	2.5, 3.3	3.6	
$V_I$	Input Voltage	0		5.5	V	
$V_O$	Output Voltage (HIGH or LOW State) (3–State)	0		$V_{CC}$	V	
		0		5.5		
$I_{OH}$	HIGH Level Output Current	$V_{CC} = 3.0 \text{ V} - 3.6 \text{ V}$		–24	mA	
		$V_{CC} = 2.7 \text{ V} - 3.0 \text{ V}$		–12		
		$V_{CC} = 2.3 \text{ V} - 2.7 \text{ V}$		–8		
$I_{OL}$	LOW Level Output Current	$V_{CC} = 3.0 \text{ V} - 3.6 \text{ V}$		+24	mA	
		$V_{CC} = 2.7 \text{ V} - 3.0 \text{ V}$		+12		
		$V_{CC} = 2.3 \text{ V} - 2.7 \text{ V}$		+8		
$T_A$	Operating Free–Air Temperature	–40		+85	°C	
$\Delta t/\Delta V$	Input Transition Rise or Fall Rate, $V_{IN}$ from 0.8 V to 2.0 V, $V_{CC} = 3.0 \text{ V}$	0		10	ns/V	

# MC74LCX16240

## DC ELECTRICAL CHARACTERISTICS

Symbol	Characteristic	Condition	$T_A = -40^\circ\text{C to } +85^\circ\text{C}$		Unit
			Min	Max	
$V_{IH}$	HIGH Level Input Voltage (Note 2)	$2.3\text{ V} \leq V_{CC} \leq 2.7\text{ V}$	1.7		V
		$2.7\text{ V} \leq V_{CC} \leq 3.6\text{ V}$	2.0		
$V_{IL}$	LOW Level Input Voltage (Note 2)	$2.3\text{ V} \leq V_{CC} \leq 2.7\text{ V}$		0.7	V
		$2.7\text{ V} \leq V_{CC} \leq 3.6\text{ V}$		0.8	
$V_{OH}$	HIGH Level Output Voltage	$2.3\text{ V} \leq V_{CC} \leq 3.6\text{ V}; I_{OL} = 100\ \mu\text{A}$	$V_{CC} - 0.2$		V
		$V_{CC} = 2.3\text{ V}; I_{OH} = -8\text{ mA}$	1.8		
		$V_{CC} = 2.7\text{ V}; I_{OH} = -12\text{ mA}$	2.2		
		$V_{CC} = 3.0\text{ V}; I_{OH} = -18\text{ mA}$	2.4		
		$V_{CC} = 3.0\text{ V}; I_{OH} = -24\text{ mA}$	2.2		
$V_{OL}$	LOW Level Output Voltage	$2.3\text{ V} \leq V_{CC} \leq 3.6\text{ V}; I_{OL} = 100\ \mu\text{A}$		0.2	V
		$V_{CC} = 2.3\text{ V}; I_{OL} = 8\text{ mA}$		0.6	
		$V_{CC} = 2.7\text{ V}; I_{OL} = 12\text{ mA}$		0.4	
		$V_{CC} = 3.0\text{ V}; I_{OL} = 16\text{ mA}$		0.4	
		$V_{CC} = 3.0\text{ V}; I_{OL} = 24\text{ mA}$		0.55	
$I_I$	Input Leakage Current	$2.3\text{ V} \leq V_{CC} \leq 3.6\text{ V}; 0\text{ V} \leq V_I \leq 5.5\text{ V}$		$\pm 5.0$	$\mu\text{A}$
$I_{OZ}$	3-State Output Current	$2.3 \leq V_{CC} \leq 3.6\text{ V}; 0\text{V} \leq V_O \leq 5.5\text{ V}; V_I = V_{IH}\text{ or } V_{IL}$		$\pm 5.0$	$\mu\text{A}$
$I_{OFF}$	Power-Off Leakage Current	$V_{CC} = 0\text{ V}; V_I\text{ or } V_O = 5.5\text{ V}$		10	$\mu\text{A}$
$I_{CC}$	Quiescent Supply Current	$2.3 \leq V_{CC} \leq 3.6\text{ V}; V_I = \text{GND or } V_{CC}$		20	$\mu\text{A}$
		$2.3 \leq V_{CC} \leq 3.6\text{ V}; 3.6 \leq V_I\text{ or } V_O \leq 5.5\text{ V}$		$\pm 20$	$\mu\text{A}$
$\Delta I_{CC}$	Increase in $I_{CC}$ per Input	$2.3 \leq V_{CC} \leq 3.6\text{ V}; V_{IH} = V_{CC} - 0.6\text{ V}$		500	$\mu\text{A}$

2. These values of  $V_I$  are used to test DC electrical characteristics only.

## AC CHARACTERISTICS $t_R = t_F = 2.5\text{ ns}; R_L = 500\ \Omega$

Symbol	Parameter	Waveform	$T_A = -40^\circ\text{C to } +85^\circ\text{C}$						Unit
			$V_{CC} = 3.3\text{ V} \pm 0.3\text{ V}$ $C_L = 50\text{ pF}$		$V_{CC} = 2.7\text{ V}$ $C_L = 50\text{ pF}$		$V_{CC} = 2.5\text{ V} \pm 0.2\text{ V}$ $C_L = 30\text{ pF}$		
			Min	Max	Min	Max	Min	Max	
$t_{PLH}$ $t_{PHL}$	Propagation Delay Input to Output	1	1.5	4.5	1.5	5.3	1.5	5.4	ns
			1.5	4.5	1.5	5.3	1.5	5.4	
$t_{PZH}$ $t_{PZL}$	Output Enable Time to High and Low Level	2	1.5	5.4	1.5	6.0	1.5	7.0	ns
			1.5	5.4	1.5	6.0	1.5	7.0	
$t_{PHZ}$ $t_{PLZ}$	Output Disable Time From High and Low Level	2	1.5	5.3	1.5	5.4	1.5	6.4	ns
			1.5	5.3	1.5	5.4	1.5	6.4	
$t_{OSHL}$ $t_{OSLH}$	Output-to-Output Skew (Note 3)			1.0					ns
				1.0					

3. Skew is defined as the absolute value of the difference between the actual propagation delay for any two separate outputs of the same device. The specification applies to any outputs switching in the same direction, either HIGH-to-LOW ( $t_{OSHL}$ ) or LOW-to-HIGH ( $t_{OSLH}$ ); parameter guaranteed by design.

# MC74LCX16240

## DYNAMIC SWITCHING CHARACTERISTICS

Symbol	Characteristic	Condition	T <sub>A</sub> = +25°C			Unit
			Min	Typ	Max	
V <sub>OLP</sub>	Dynamic LOW Peak Voltage (Note 4)	V <sub>CC</sub> = 3.3 V, C <sub>L</sub> = 50 pF, V <sub>IH</sub> = 3.3 V, V <sub>IL</sub> = 0 V		0.8		V
		V <sub>CC</sub> = 2.5 V, C <sub>L</sub> = 30 pF, V <sub>IH</sub> = 2.5 V, V <sub>IL</sub> = 0 V		0.6		V
V <sub>OLV</sub>	Dynamic LOW Valley Voltage (Note 4)	V <sub>CC</sub> = 3.3 V, C <sub>L</sub> = 50 pF, V <sub>IH</sub> = 3.3 V, V <sub>IL</sub> = 0 V		-0.8		V
		V <sub>CC</sub> = 2.5 V, C <sub>L</sub> = 30 pF, V <sub>IH</sub> = 2.5 V, V <sub>IL</sub> = 0 V		-0.6		V

4. Number of outputs defined as "n". Measured with "n-1" outputs switching from HIGH-to-LOW or LOW-to-HIGH. The remaining output is measured in the LOW state.

## CAPACITIVE CHARACTERISTICS

Symbol	Parameter	Condition	Typical	Unit
C <sub>IN</sub>	Input Capacitance	V <sub>CC</sub> = 3.3 V, V <sub>I</sub> = 0 V or V <sub>CC</sub>	7	pF
C <sub>OUT</sub>	Output Capacitance	V <sub>CC</sub> = 3.3 V, V <sub>I</sub> = 0 V or V <sub>CC</sub>	8	pF
C <sub>PD</sub>	Power Dissipation Capacitance	10 MHz, V <sub>CC</sub> = 3.3 V, V <sub>I</sub> = 0 V or V <sub>CC</sub>	20	pF

# MC74LCX16240

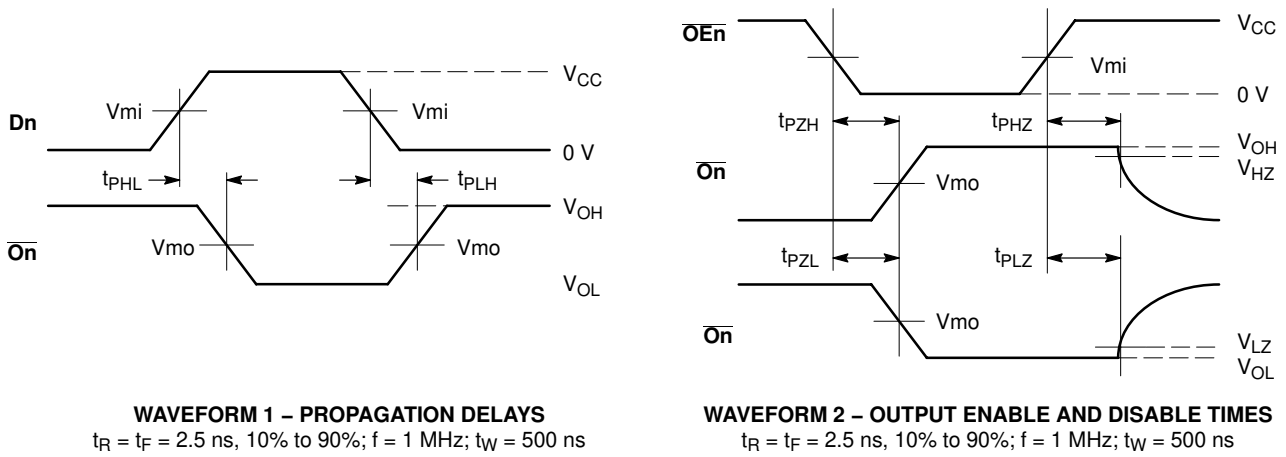

Figure 3. AC Waveforms

Table 2. AC WAVEFORMS

Symbol	V <sub>CC</sub>		
	3.3 V ± 0.3 V	2.7 V	2.5 V ± 0.2 V
V <sub>mi</sub>	1.5 V	1.5 V	V <sub>CC</sub> / 2
V <sub>mo</sub>	1.5 V	1.5 V	V <sub>CC</sub> / 2
V <sub>HZ</sub>	V <sub>OL</sub> + 0.3 V	V <sub>OL</sub> + 0.3 V	V <sub>OL</sub> + 0.15 V
V <sub>LZ</sub>	V <sub>OH</sub> - 0.3 V	V <sub>OH</sub> - 0.3 V	V <sub>OH</sub> - 0.15 V

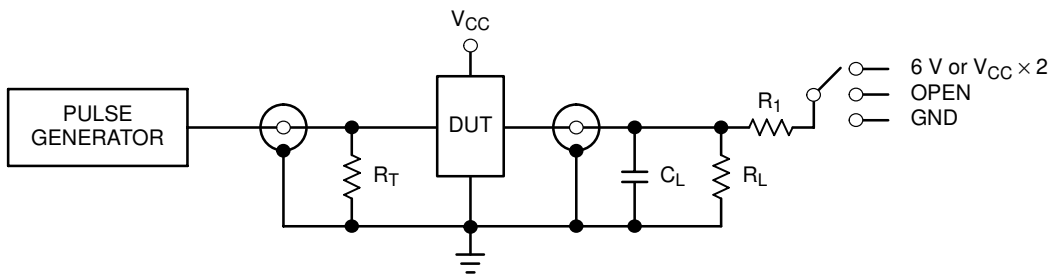

Figure 4. Test Circuit

Table 3. TEST CIRCUIT

TEST	SWITCH
t <sub>PLH</sub> , t <sub>PHL</sub>	Open
t <sub>PZL</sub> , t <sub>PLZ</sub>	6 V at V <sub>CC</sub> = 3.3 ± 0.3 V 6 V at V <sub>CC</sub> = 2.5 ± 0.2 V
Open Collector/Drain t <sub>PLH</sub> and t <sub>PHL</sub>	6 V
t <sub>PZH</sub> , t <sub>PHZ</sub>	GND

C<sub>L</sub> = 50 pF at V<sub>CC</sub> = 3.3 ± 0.3 V or equivalent (includes jig and probe capacitance)  
 C<sub>L</sub> = 30 pF at V<sub>CC</sub> = 2.5 ± 0.2 V or equivalent (includes jig and probe capacitance)  
 R<sub>L</sub> = R<sub>1</sub> = 500 Ω or equivalent  
 R<sub>T</sub> = Z<sub>OUT</sub> of pulse generator (typically 50 Ω)

# MC74LCX16240

## PACKAGE DIMENSIONS

TSSOP-48  
DT SUFFIX  
CASE 1201-01  
ISSUE A

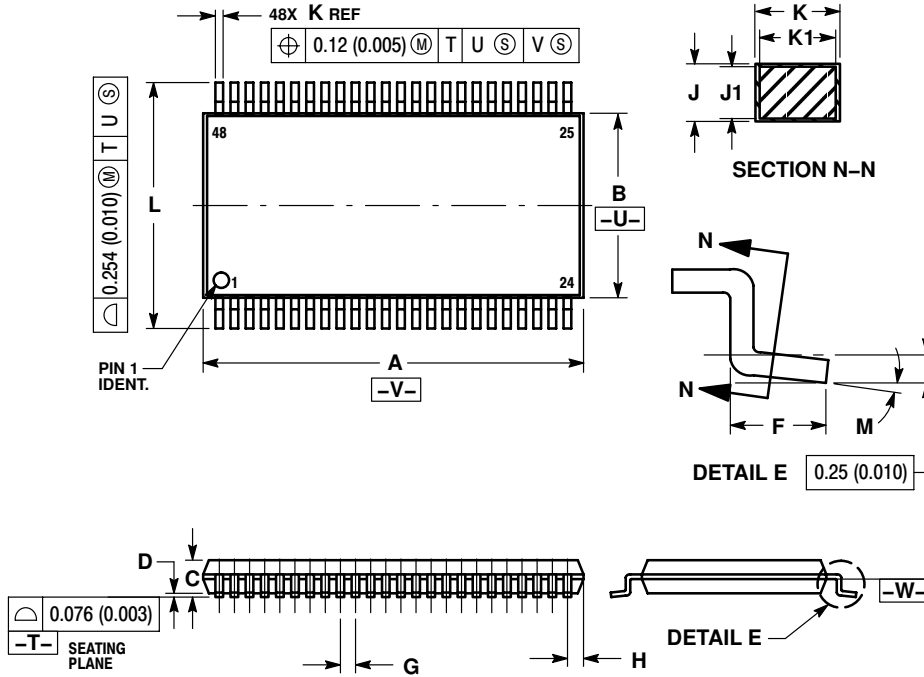

**NOTES:**

1. DIMENSIONING AND TOLERANCING PER ANSI Y14.5M, 1982.
2. CONTROLLING DIMENSION: MILLIMETER.
3. DIMENSIONS A AND B DO NOT INCLUDE MOLD FLASH, PROTRUSIONS OR GATE BURRS. MOLD FLASH OR GATE BURRS SHALL NOT EXCEED 0.15 (0.006) PER SIDE.
4. DIMENSION K DOES NOT INCLUDE DAMBAR PROTRUSION. ALLOWABLE DAMBAR PROTRUSION SHALL BE 0.08 (0.003) TOTAL IN EXCESS OF THE K DIMENSION AT MAXIMUM MATERIAL CONDITION.
5. TERMINAL NUMBERS ARE SHOWN FOR REFERENCE ONLY.
6. DIMENSIONS A AND B ARE TO BE DETERMINED AT DATUM PLANE -W-.

DIM	MILLIMETERS		INCHES	
	MIN	MAX	MIN	MAX
A	12.40	12.60	0.488	0.496
B	6.00	6.20	0.236	0.244
C	---	1.10	---	0.043
D	0.05	0.15	0.002	0.006
F	0.50	0.75	0.020	0.030
G	0.50 BSC		0.0197 BSC	
H	0.37	---	0.015	---
J	0.09	0.20	0.004	0.008
J1	0.09	0.16	0.004	0.006
K	0.17	0.27	0.007	0.011
K1	0.17	0.23	0.007	0.009
L	7.95	8.25	0.313	0.325
M	0 °	8 °	0 °	8 °

# MC74LCX16240

**ON Semiconductor** and  are registered trademarks of Semiconductor Components Industries, LLC (SCILLC). SCILLC reserves the right to make changes without further notice to any products herein. SCILLC makes no warranty, representation or guarantee regarding the suitability of its products for any particular purpose, nor does SCILLC assume any liability arising out of the application or use of any product or circuit, and specifically disclaims any and all liability, including without limitation special, consequential or incidental damages. "Typical" parameters which may be provided in SCILLC data sheets and/or specifications can and do vary in different applications and actual performance may vary over time. All operating parameters, including "Typicals" must be validated for each customer application by customer's technical experts. SCILLC does not convey any license under its patent rights nor the rights of others. SCILLC products are not designed, intended, or authorized for use as components in systems intended for surgical implant into the body, or other applications intended to support or sustain life, or for any other application in which the failure of the SCILLC product could create a situation where personal injury or death may occur. Should Buyer purchase or use SCILLC products for any such unintended or unauthorized application, Buyer shall indemnify and hold SCILLC and its officers, employees, subsidiaries, affiliates, and distributors harmless against all claims, costs, damages, and expenses, and reasonable attorney fees arising out of, directly or indirectly, any claim of personal injury or death associated with such unintended or unauthorized use, even if such claim alleges that SCILLC was negligent regarding the design or manufacture of the part. SCILLC is an Equal Opportunity/Affirmative Action Employer. This literature is subject to all applicable copyright laws and is not for resale in any manner.

## PUBLICATION ORDERING INFORMATION

### LITERATURE FULFILLMENT:

Literature Distribution Center for ON Semiconductor  
P.O. Box 61312, Phoenix, Arizona 85082-1312 USA  
**Phone:** 480-829-7710 or 800-344-3860 Toll Free USA/Canada  
**Fax:** 480-829-7709 or 800-344-3867 Toll Free USA/Canada  
**Email:** [orderlit@onsemi.com](mailto:orderlit@onsemi.com)

**N. American Technical Support:** 800-282-9855 Toll Free  
USA/Canada

**Japan:** ON Semiconductor, Japan Customer Focus Center  
2-9-1 Kamimeguro, Meguro-ku, Tokyo, Japan 153-0051  
**Phone:** 81-3-5773-3850

**ON Semiconductor Website:** <http://onsemi.com>

**Order Literature:** <http://www.onsemi.com/litorder>

For additional information, please contact your  
local Sales Representative.

**MC74LCX16240/D**