

OVERVIEW

High performance motion detection lens for security and lighting applications. 360deg beam pattern with 100deg FOV and up to 7m field at 2.4m mounting height, ideal for ceiling mount applications. Tightly packed zones for minor motion detection.



Dome Cap Lens 360

FEATURES

- Designed to press onto standard T05 pyro
- Automatically sets correct focal distance
- Designed using optical ray-tracing software
- Compact shape with clearance for pcb components
- Available in natural, white and black colours

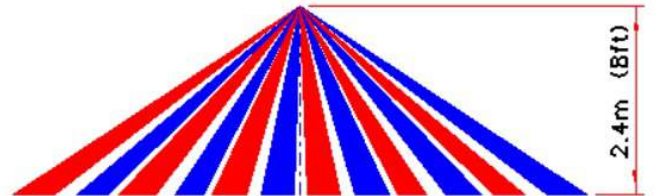

Part Number	Drawing	Colour
709-N	A3-10709	Natural
709-W	A3-10709	White
709-B	A3-10709	Black

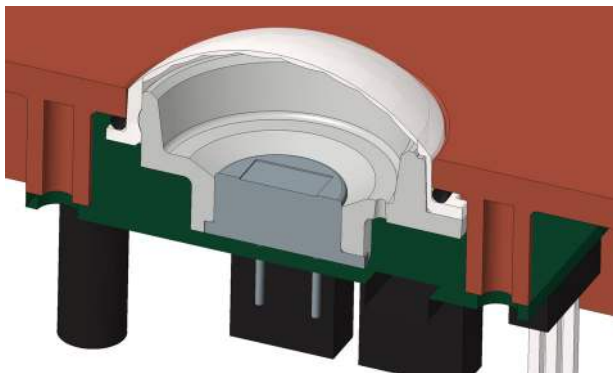
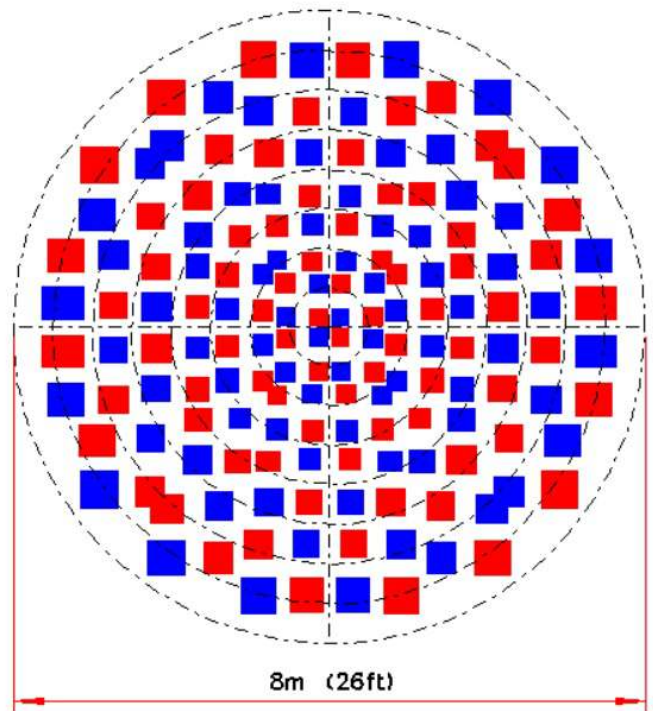

Typical mounting method: 20x1mm o-ring stretched around lens flange. PCB screwed to housing via pillars. Orientation tab sits in channel next to fixing pillar.

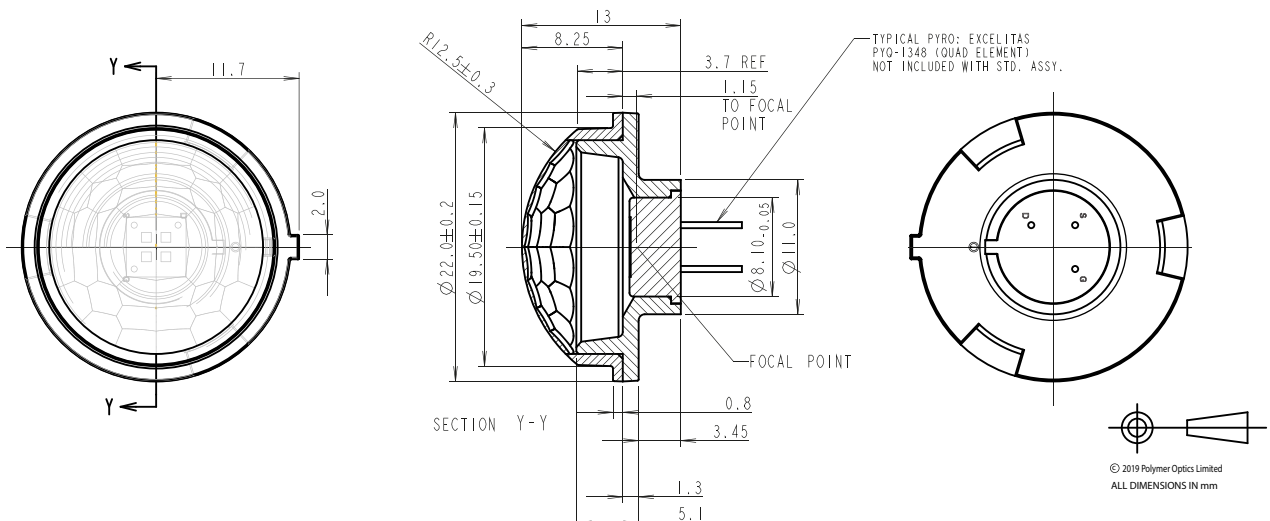

FEATURES

- Designed to press onto standard T05 pyro
- Horizontal curtain and circular beam patterns
- Choice of profile shape to suit product styling
- Designed using optical ray-tracing software
- Compact shape with clearance for pcb components
- Available in natural, white and black colours

APPLICATIONS

- Office and household lighting control
- Motion detection for security applications
- Individual luminaire switching
- Fan and air conditioning control
- Control panel illumination for appliances
- Vending machines, ATM's, streetlights



Dome Cap Lens HC



Dome Cap Lens 360



Flat Cap Lens HC



Flat Cap Lens 360

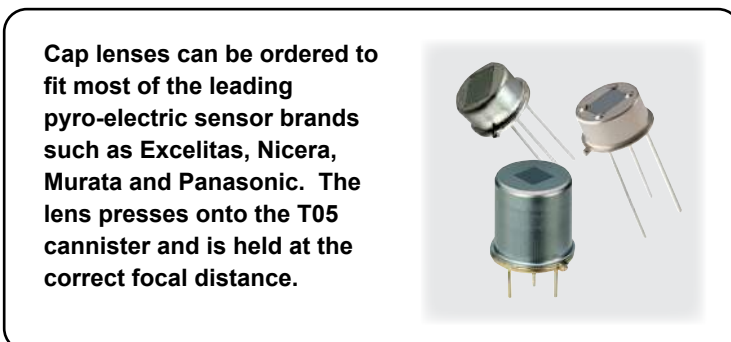
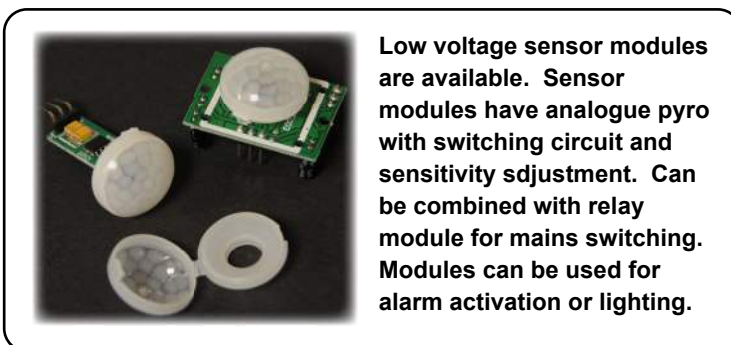
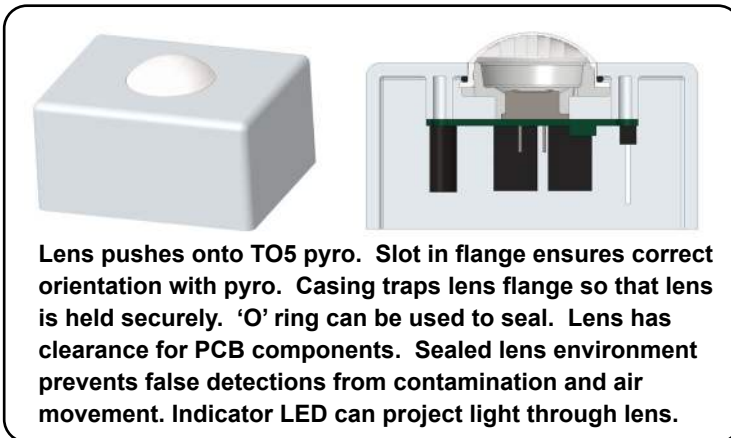

Small and compact, these lenses are suitable for numerous security and lighting applications, in the office, or around the home. Available in two beam pattern versions, horizontal curtain (HC) and 360deg ceiling, there is a lens suitable for every application.