

# LTC4067

## USB Power Control with Li-Ion/Polymer Charger

### DESCRIPTION

Demonstration circuit 943 is a complete power controller for a USB power device. It is based on the LTC4067 and provides the following functions:

Full featured battery charger with 4.2V float, USB power manager that ensures compliance with the USB power specification and a power path manager for the battery. Wall adapter input with overvoltage protection to 13V.

**Design files for this circuit board are available. Call the LTC factory.**

LT, LTC, LTM, LT, Burst Mode, OPTI-LOOP, Over-The-Top and PolyPhase are registered trademarks of Linear Technology Corporation. Adaptive Power, C-Load, DirectSense, Easy Drive, FilterCAD, Hot Swap, LinearView,  $\mu$ Module, Micropower SwitcherCAD, Multimode Dimming, No Latency  $\Delta\Sigma$ , No Latency Delta-Sigma, No  $R_{SENSE}$ , Operational Filter, PanelProtect, PowerPath, PowerSOT, SmartStart, SoftSpan, Stage Shedding, SwitcherCAD, ThinSOT, UltraFast and VLDO are trademarks of Linear Technology Corporation. Other product names may be trademarks of the companies that manufacture the products.

### PERFORMANCE SUMMARY Specifications are at TA = 25°C

SYMBOL	PARAMETER	CONDITIONS	MIN	TYP	MAX	UNITS
$V_{IN}$	Input Supply Range - USB		4.35		5.5	V
$V_{OVI}$	Input Supply Range - Wall Adapter	(Withstands up to 13V without damage)	4.35		6	V
$V_{OVITH}$	Overvoltage Protection Threshold (OVI pin)	Rising threshold	5.8	6	6.2	V
<b>Battery Charger</b>						
$I_{OUT}$	Charging current	$V_{IN} = 5V, V_{BAT} = 3.6V, R_{10} = 2.10k\Omega$	448	476	505	mA
$V_{FLOAT}$	Float Voltage	$V_{IN} = 5V$	4.167	4.2	4.215	V
$I_{TRIKL}$	Trickle Charge Current	$V_{BAT} = 2V$	33	48	57	mA
$V_{RECHRG}$	Recharge threshold	$V_{FLOAT} - V_{RECHRG}$	65	100	135	mV
<b>Input Current</b>						
$I_{LIM}$	Input current 100mA mode	$V_{ILIM0} = V_{ILIM1} = 0V$	86	93	105	mA
$I_{LIM}$	Input Current 500mA mode	$V_{ILIM0} = V_{ILIM1} = 5V$	452	476	500	mA
$I_{IN(MAX)}$	Maximum Input Current Limit	$V_{ILIM0} = 5V, V_{ILIM1} = 0V$	1.5	2		A
$I_{IN(SUSP)}$	Suspend Mode Input Current	$V_{ILIM0} = 0V, V_{ILIM1} = 5V, \text{No load}$		52	90	$\mu$ A

### OPERATING PRINCIPLES

Demo board DC943A is based on the LTC4067. This chip manages the power supplies that would be typical for a USB powered device. Power is input from either the USB cable or from an adapter to an intermediate voltage bus. The intermediate voltage bus is powered from USB or adapter when available, and from the battery via an ideal diode. The battery charger is a CC/CV timer terminated type capable of charge currents up to 1.25A

The adapter input has overvoltage protection to 13V. An external MOSFET will disconnect the adapter if the voltage exceeds 6V, protecting the input against damage in case an unregulated adapter is accidentally plugged in.

position and connect the external NTC to the NTC terminal and ground. To disable the NTC temperature qualified charging function, ground the NTC pin by setting JP2 in the DISable position.

12. Charge current can be monitored at the I-CHG pin and input current can be monitored at the I-INPUT pin.

13. Pins have been provided to all control functions in order to simplify wiring the demo circuit into a system board.

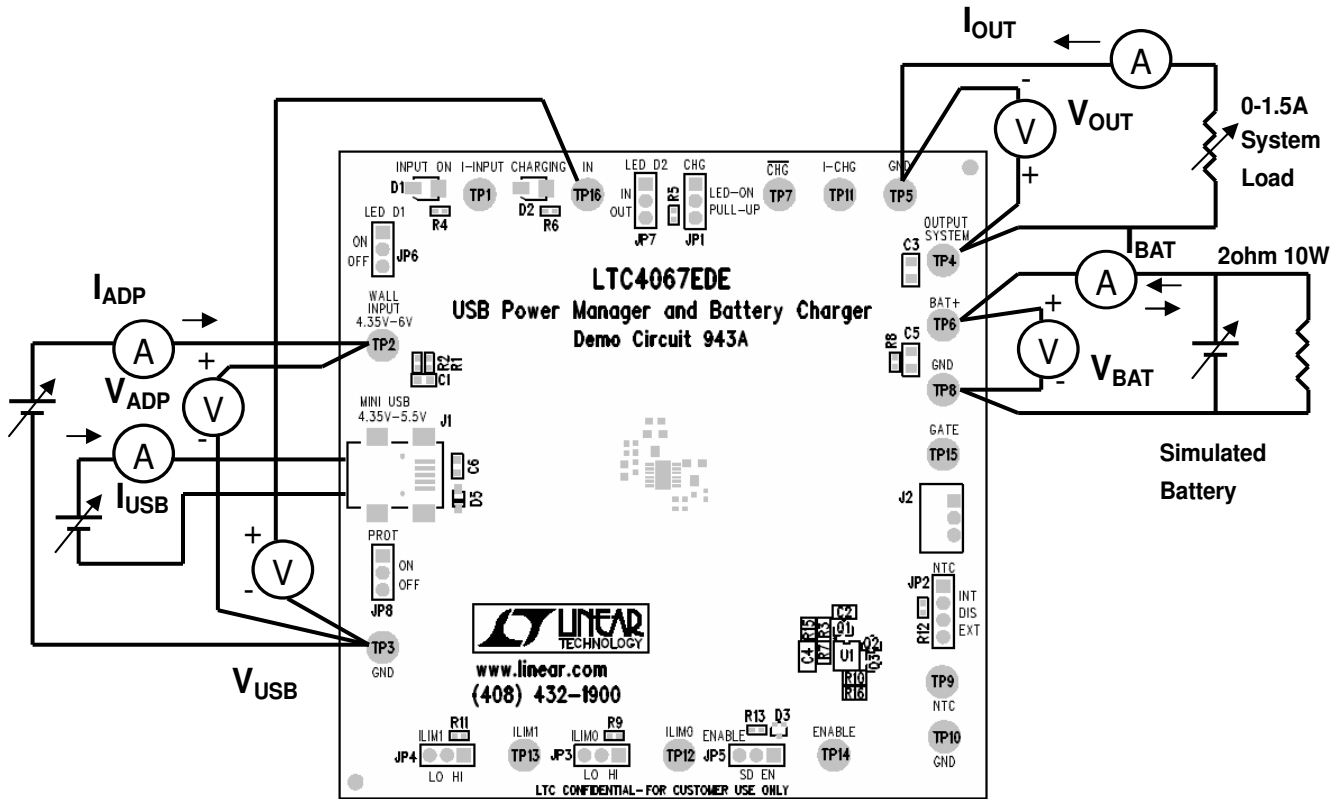

Figure 1. Proper Measurement Equipment Setup

Note: Only one power supply at a time should be connected to the WALL and USB inputs. Remove the USB cable while testing the WALL INPUT and remove the WALL INPUT power supply while testing the USB input.

## QUICK START PROCEDURE

Demonstration circuit 943 is easy to set up to evaluate the performance of the LTC4067. Refer to Figure 1 for proper measurement equipment setup and follow the procedure below:

1. With power off, connect the input power supply, meters and output load as shown in Figure 1. For the USB input, use an adjustable 0-5V 0.5A power supply and a cable with a USB Mini-B connector that plugs into J1. For the wall adapter input, use a 0-10V 2A adjustable power supply. For simulating the battery, use a 0-5V adjustable power supply that can deliver at least 3A, in parallel with a 2Ω 10W power resistor. Attach a 0-1.5A adjustable load to the System Output.
2. Check that the jumpers are in their default positions as shown in the schematic.

### USB Charging

3. First unplug the Wall Adapter power supply from WALL INPUT. Set the battery simulator voltage at zero. Set the system load at zero. Slowly rise the USB input voltage. LED D1 will illuminate to indicate that input voltage is present. When the USB voltage exceeds 3.8V the charger should activate and charger LED D2 will illuminate. The battery will be in trickle charge mode. Slowly increase the battery voltage to 3.6V and note that when the battery voltage is above 2.9V the battery charge current will increase to about 475mA.
4. Now increase the system load and note that as the load is increased the charging current is decreased and the USB current remains within the 500mA limit. If the load exceeds the input current limit the excess current will be drawn from the battery through the ideal diode.
5. Place the ILIM0 and ILIM1 jumpers in the LO position and note that USB current falls to maintain compliance with the USB 100mA limit spec. Also note that as the system load is increased above 100mA the battery will start to discharge, illustrating the ideal diode function of the LTC4067.

6. Place the JP6 jumper in the OFF position to avoid that the LED current interferes with the next measurement. Place the ILIM1 jumper in the HI position and note that the USB current falls to comply with the USB Suspend mode current spec.

### Adapter Charging

7. Unplug the USB cable. Connect the Wall Adapter power supply to WALL INPUT. Set the ILIM0 jumper to the HI position and the ILIM1 jumper to the LO position. Increase the wall adapter voltage. When it exceeds 3.8V the charger should activate. Set the wall adapter input voltage at 5V. Note that the charge current still is 475mA, and as the System Load is increased (up to 1.5A max), the sum of these currents will be drawn from the wall adapter input. Battery charging continues at programmed current level.
8. Increase the wall adapter input slowly and note that as the voltage exceeds 6V the external MOSFET Q1 will disconnect the wall adapter from the input of the LTC4067 (The voltmeter at IN (TP16) indicates zero volts). The System Load is now powered from the battery. Decrease the wall adapter voltage to 5V and note that Q1 will connect the wall adapter to the input of the LTC4067 as the voltage drops below the overvoltage protection limit of 6V.
9. Increase the battery voltage to 4.2V and note that the charge current falls to zero. This illustrates the constant voltage portion of the charging characteristics.

### Battery Powered Operation

10. Set the battery voltage to 3.6V. Set wall adapter voltage to zero. The battery will now power the load, illustrating the ideal diode function of the LTC4067.

### Other

11. Provision has been made to connect an external 10k NTC for temperature qualified charging. To use this feature set the NTC jumper JP2 in the EXTERNAL

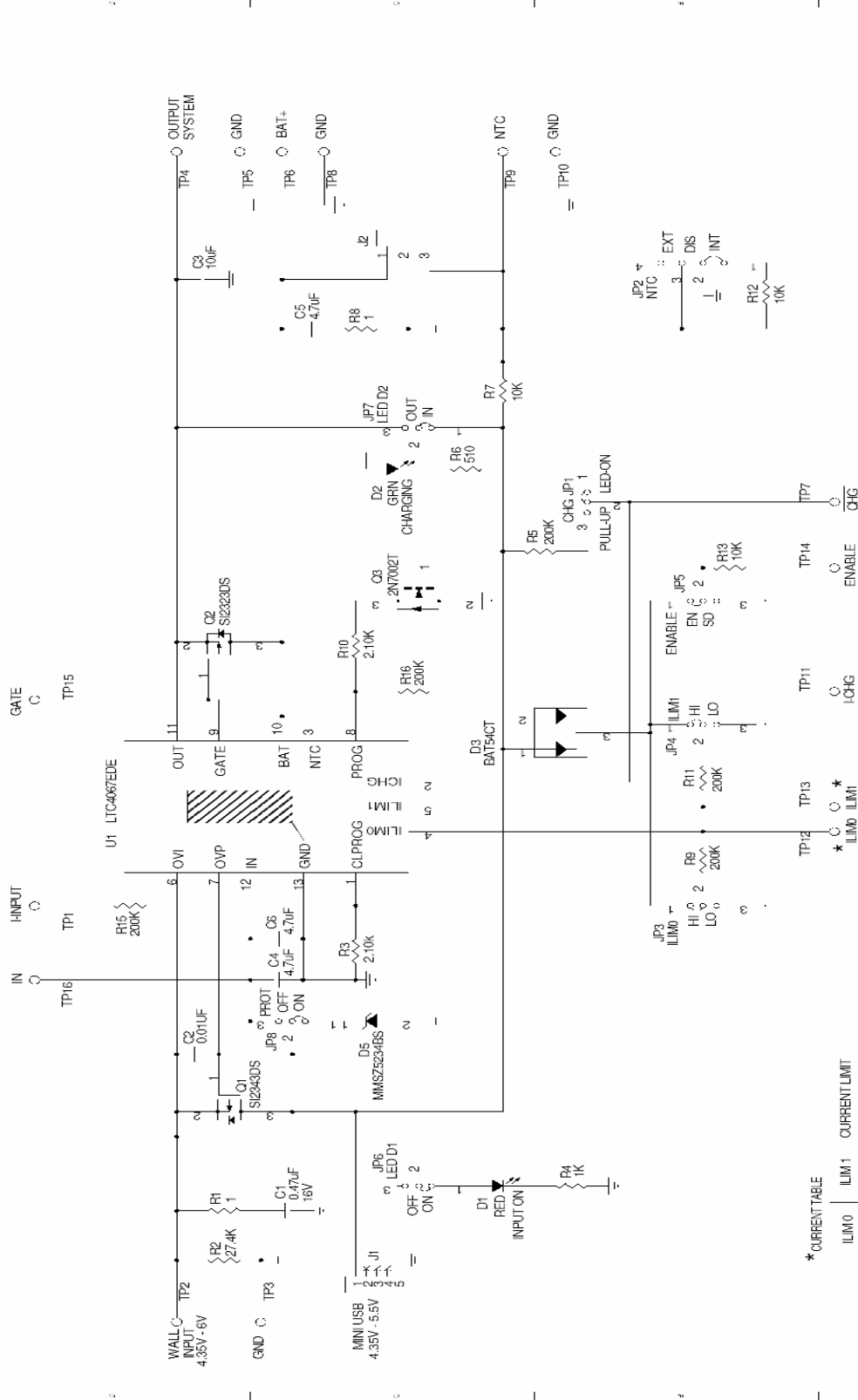

\* CURRENT TABLE

ILIM0	ILIM1	CURRENT LIMIT
LO	LO	100mA
LO	HI	0mA
HI	LO	2000mA
HI	HI	500mA

**LTC4067E**  
USB Power Manager and Battery Charger

CONTRACT NO.		APPROVALS		DATE	
DRAWN		TAG'D		11/20/01	
CHECKED		APPROVED		TITLE	
REVISE		REVISED		LTC4067E	
REVISED		REVISED		SIZE	
REVISED		REVISED		A4	
REVISED		REVISED		FILE NAME	
REVISED		REVISED		DC943A	
REVISED		REVISED		SHEET	
REVISED		REVISED		1	
REVISED		REVISED		OF	
REVISED		REVISED		1	

**CUSTOMER NOTICE**  
 LINEAR TECHNOLOGY HAS MADE A BEST EFFORT TO DESIGN A CIRCUIT THAT MEETS CUSTOMER SPECIFIED OPERATIONS; HOWEVER, IT REMAINS THE CUSTOMER'S RESPONSIBILITY TO VERIFY PROPER AND RELIABLE OPERATION IN THE ACTUAL APPLICATION. COMPONENT SUBSTITUTIONS ARE PRINTED ON THIS BOARD LAYOUT BUT SIGNIFICANTLY AFFECT CIRCUIT PERFORMANCE OR RELIABILITY. CONTACT LINEAR TECHNOLOGY APPLICATIONS ENGINEERING FOR ASSISTANCE.  
 THIS CIRCUIT IS PROPRIETARY TO LINEAR TECHNOLOGY AND SUPPLIED FOR USE WITH LINEAR TECHNOLOGY PARTS.

Nonrep. board size: 26.22W  
 SCALE: 1:1  
 FILE NAME: DC943A

Item	Qty	Reference	Part Description	Manufacturer / Part #
<b>REQUIRED CIRCUIT COMPONENTS:</b>				
1	1	C2	CAP., X7R, 0.01uF, 50V, 10%, 0603	TDK, C1608X7R1H103K
2	1	C3	CAP., X5R, 10uF, 6.3V, 10%, 0805	TDK, C2012X5R0J106K
3	2	C4,C6	CAP., X5R, 4.7uF, 10V, 20%, 0603	TAIYO YUDEN, LMK107BJ475KA-T
4	2	R3,R10	RES., CHIP, 2.10K, 1/16W, 1%, 0402	VISHAY, CRCW04022K10FKED
5	1	Q1	XSTR, MOSFET P- CHANNEL, SOT23	VISHAY, SI2343DS-T1-E3
6	1	U1	I.C LTC4067EDE#PBF, 4X3mm DFN	LINEAR TECH., LTC4067EDE#PBF
<b>ADDITIONAL DEMO BOARD CIRCUIT COMPONENTS:</b>				
1	1	C1	CAP., X5R, 0.47uF, 16V, 20%, 0603	TDK, C1608X5R1C474M
2	1	C5	CAP., X5R, 4.7uF, 10V, 10%, 0805	TAIYO YUDEN, LMK212BJ475KD-T
3	1	D1	LED., RED, 4V,	PANASONIC, LN1251C-(TR)
4	1	D2	LED., GREEN, 4V,	PANASONIC, LN1351C-(TR)
5	1	D3	DIODE, 30V, SOT-523	DIODES, BAT54CT-7
6	1	D5	DIODE, SOD-323	DIODES, MMSZ5234BS-7-F
7	1	Q2	XSTR, MOSFET P- CHANNEL, SOT23	VISHAY, SI2323DS-T1-E3
8	1	Q3	N-CHANNEL TRANSISTOR, SOT-523	DIODES, 2N7002T-7-F
9	2	R1,R8	RES., CHIP, 1, 1/16W, 1%, 0402	VISHAY, CRCW04021R00FNED
10	1	R2	RES., CHIP, 27.4K, 1/16W, 1%, 0402	AAC, CR05-2742FM
11	1	R4	RES., CHIP, 1K, 1/16W, 1%, 0402	AAC, CR05-1001FM
12	5	R5,R9,R11,R15,R16	RES., CHIP, 200K, 1/16W, 1%, 0402	VISHAY, CRCW0402200KFKED
13	1	R6	RES., CHIP, 510, 1/16W, 5%, 0402	VISHAY, CRCW0402510RJNED
14	3	R7,R12,R13	RES., CHIP, 10K, 1/16W, 1%, 0402	AAC, CR05-1002FM
<b>HARDWARE-FOR DEMO BOARD ONLY:</b>				
1	7	JP1,JP3-JP8	0.079 SINGLE ROW HEADER, 3 PIN	SAMTEC, TMM-103-02-L-S
2	1	JP2	0.079 SINGLE ROW HEADER, 4PIN	SAMTEC, TMM-104-02-L-S
3	8	JP1-JP8	SHUNT.	SAMTEC, 2SN-BK-G
4	16	TP1-TP16	TURRETS, .095"	MILL-MAX 2501-2-00-80-00-00-07-00
5	1	J1	CONN. USB MINI-A	TYCO ELECTRONICS, 440247-2
6	1	J2	HEADER, 3PIN	HIROSE ELECTRIC, DF3A-3P-2DSA