

LOC		DIST		REVISIONS			
P	LTR	DESCRIPTION	DATE	DNW	APVD		
N		REV PER ECO-15-016062	10NOV15	KG	CD		

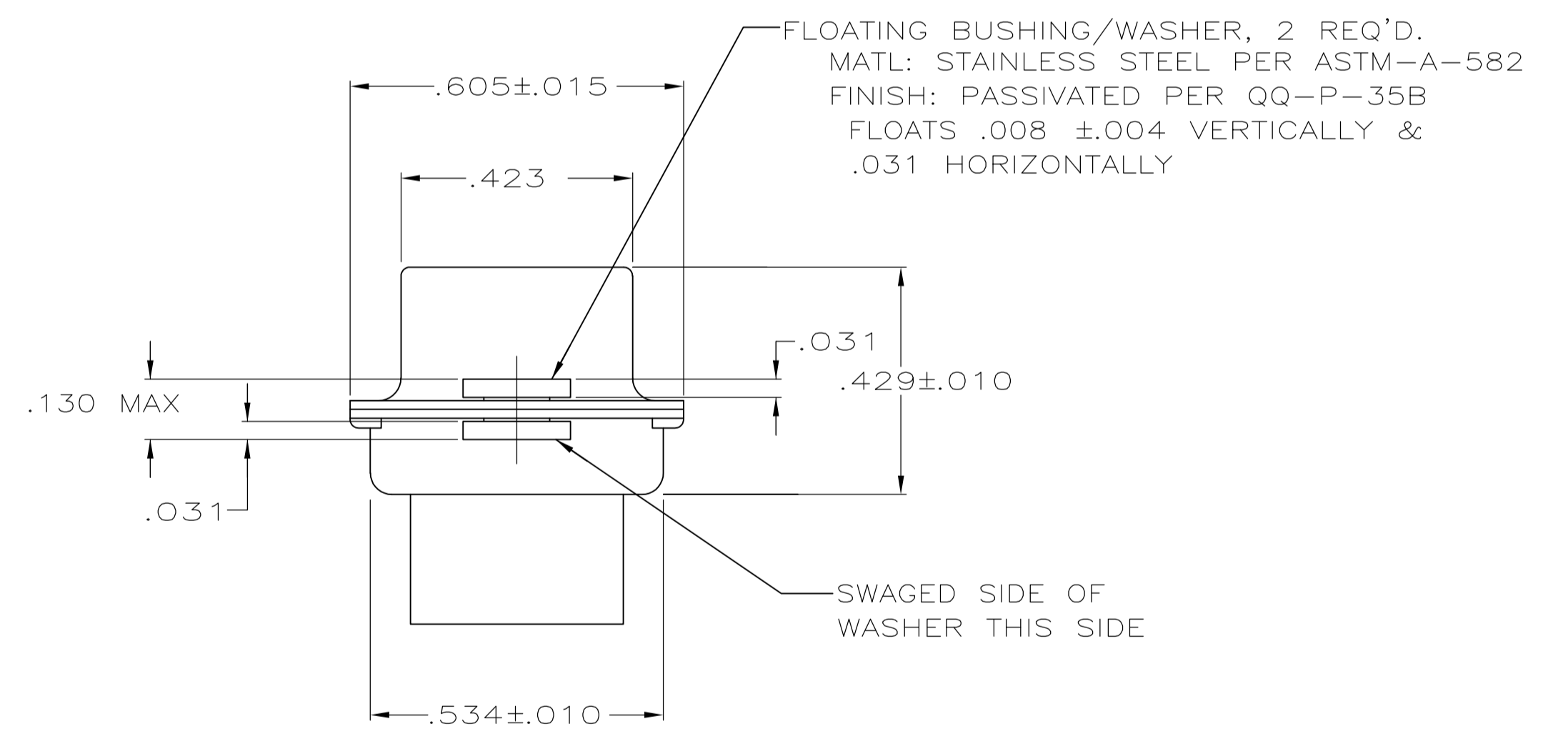
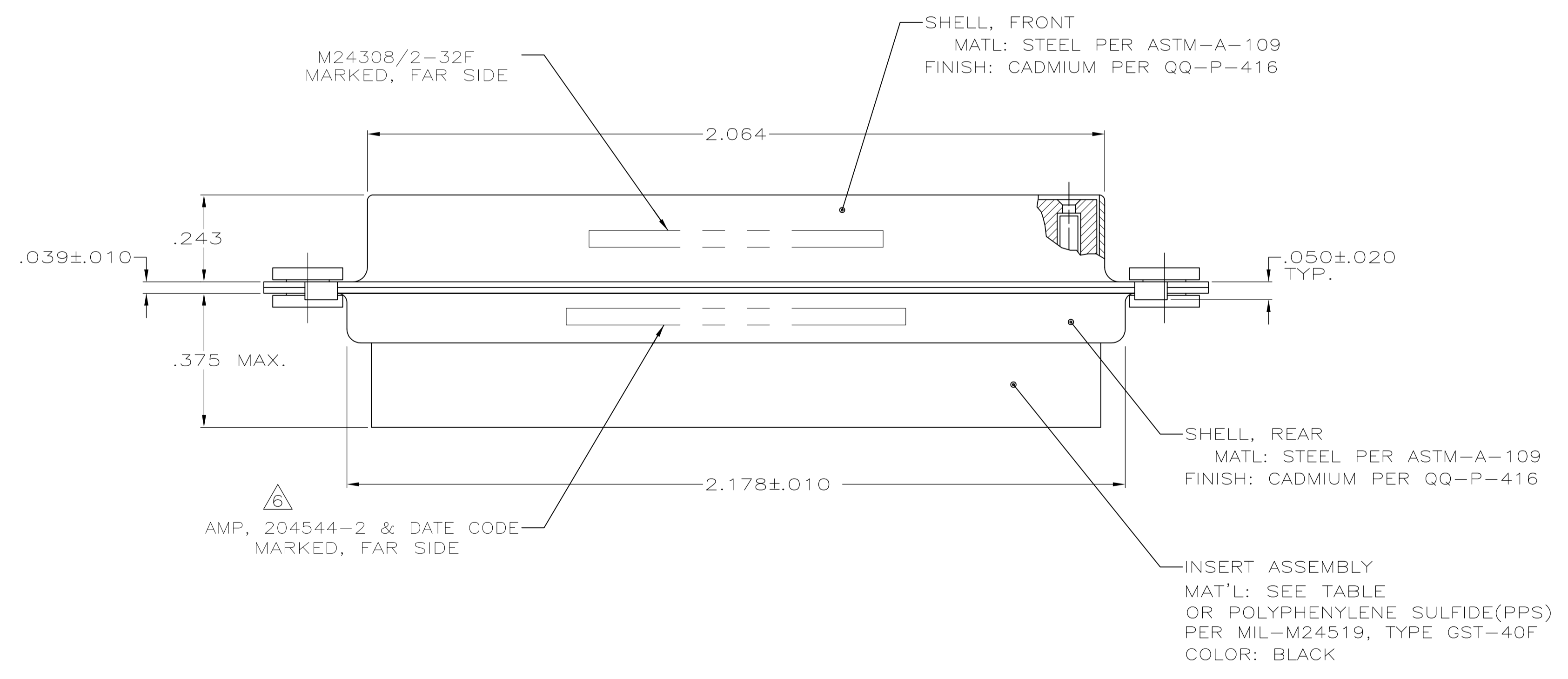
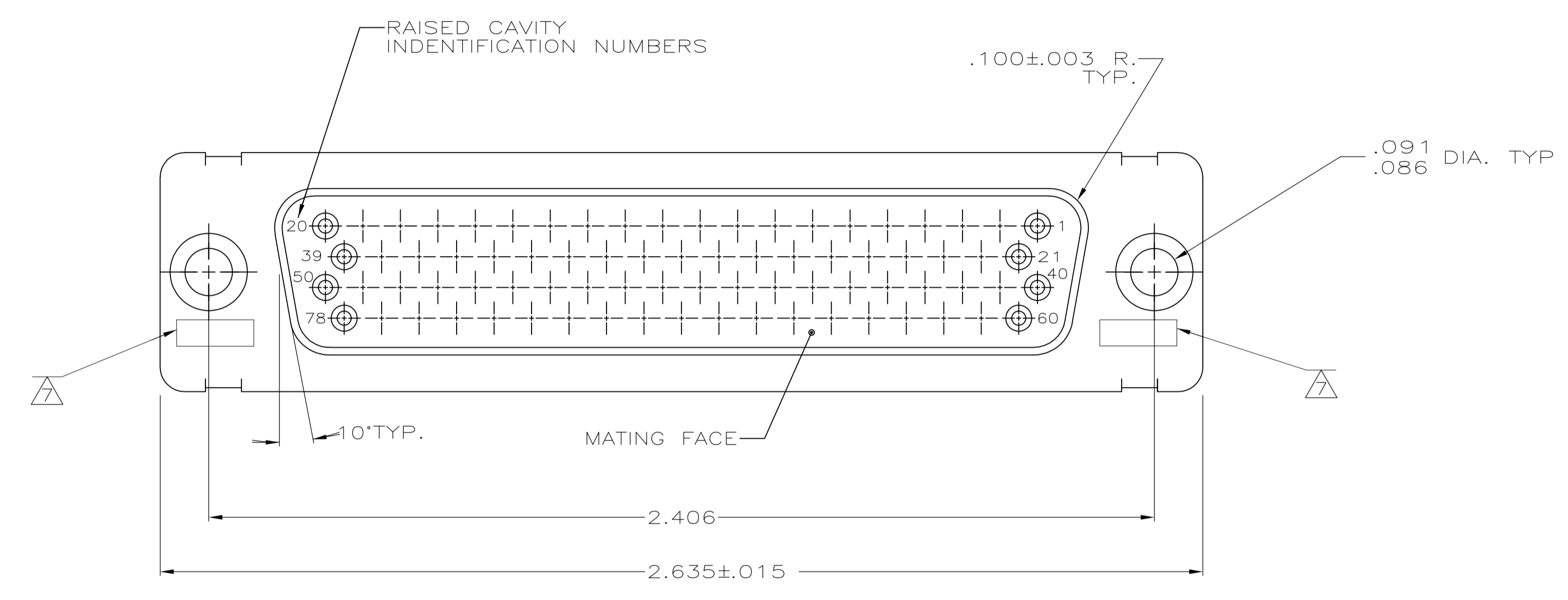

1. THIS RCPT. IS DESIGNED TO CONFORM TO THE LATEST ISSUE OF MIL-C-24308
 2. MAX WIRE INSUL TO BE USED WITH THIS RCPT IS .054 DIA
 3. METAL RETENTION CLIPS ARE INCLUDED IN INSERTS
 4. PACKAGE MARKED M 24308/2-301F
 5. THIS RCPT. WILL ACCEPT SIZE 22 SOCKET CONTACT M 24308/12 OR AMP # 204351
- AMP PART NO. MARKED ON CONNECTOR REPRESENTS KIT NUMBER WITH CONTACTS
 UL/CSA DESIGNATION MARKED IN THIS AREA, OPTIONAL

THIS DRAWING IS A CONTROLLED DOCUMENT.

DIMENSIONS: INCHES	TOLERANCES UNLESS OTHERWISE SPECIFIED:	DIN 12-4-87	C.C. THOMAS
0. PLC ± -	1. PLC ± -	1-25-88	F.C. RALLEW
2. PLC ± -	3. PLC ± .005	1-25-88	F.C. RALLEW
4. PLC ANGLES ± -	± 0'30"		

MATERIAL: SEE CALLOUTS
 FINISH: SEE CALLOUTS
 WEIGHT: --
 SIZE: A1
 CAGE CODE: 00779
 DRAWING NO: 204532
 CUSTOMER DRAWING
 SCALE: 4:1
 SHEET: 1 OF 1
 REV: N

STE TE Connectivity
 NAME: AMPLIMITE RCPT. FOR SOCKET CONTACTS HI DENSITY D CONNECTOR, SIZE 5, 78 POSN., SERIES 90 WITH FLOAT BUSHINGS