

THIS DRAWING IS UNPUBLISHED. RELEASED FOR PUBLICATION  
 © COPYRIGHT - By - ALL RIGHTS RESERVED.

LOC	DIST	REVISIONS					
CM	53	P	LTR	DESCRIPTION	DATE	DWN	APVD
		AA		REVISED PER ECR-16-002894	24MAR2016	BW	EW

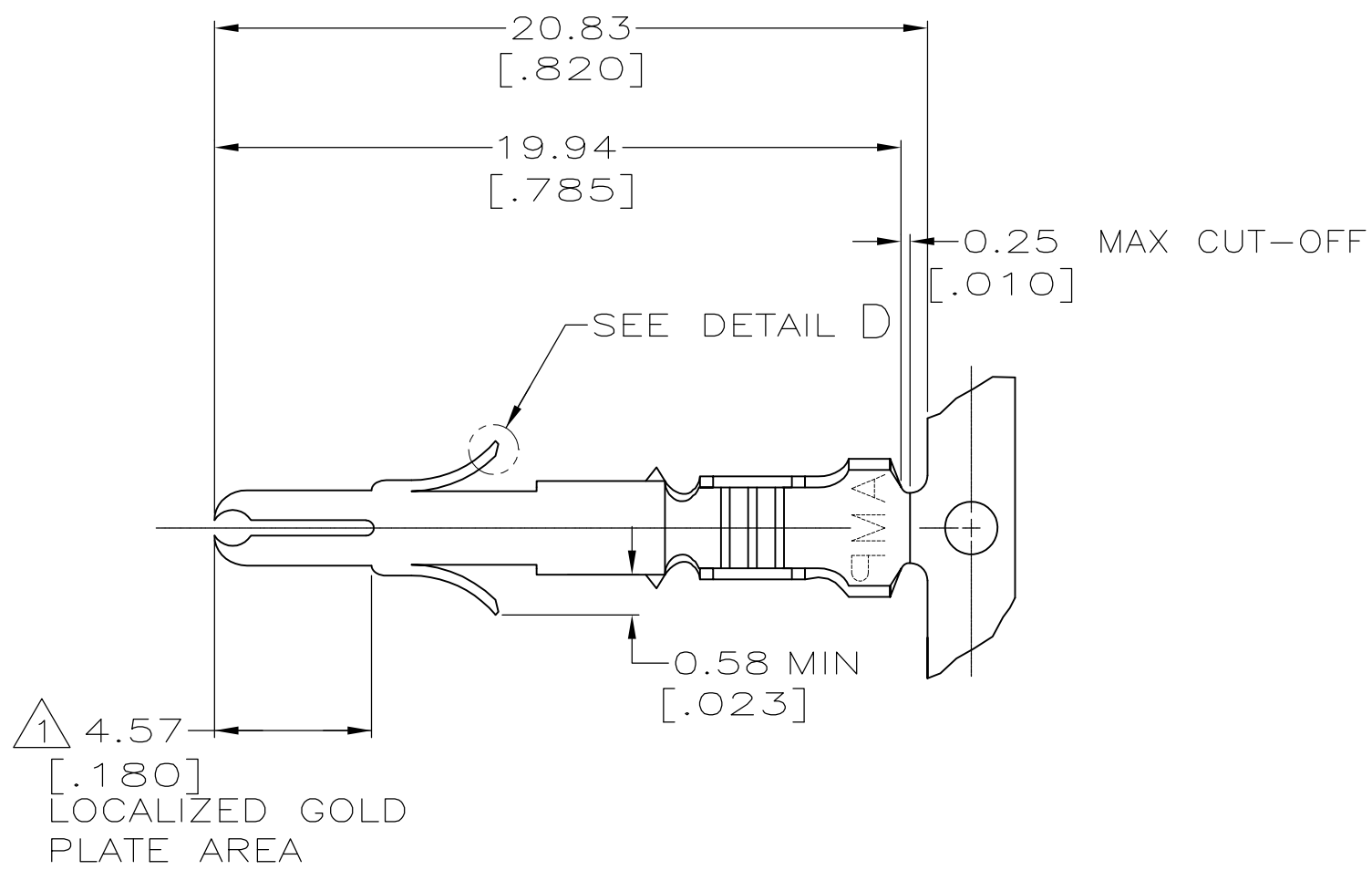

- 1 PLATED WITH 0.00076 [.000030] GOLD, OVER 0.00127 [.000050] NICKEL UNDERPLATE.
- 2 PLATED INTERNALLY WITH 0.00076 [.000030] GOLD.
- 3 DIMENSIONS IN BRACKETS ARE IN INCHES.
- 4 PRELIMINARY, NOT FOR PRODUCTION.
- 5 INSULATION RANGE: 1.52-3.30 [.060-.130] DIA.

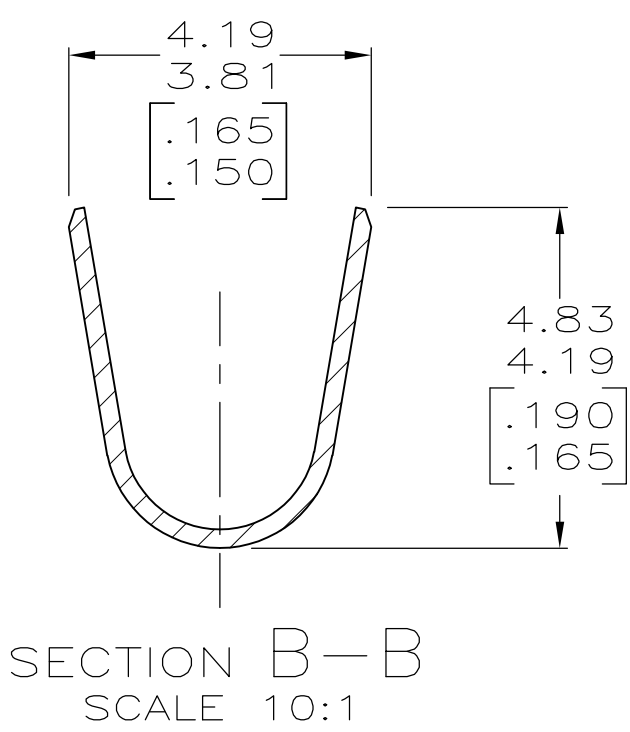
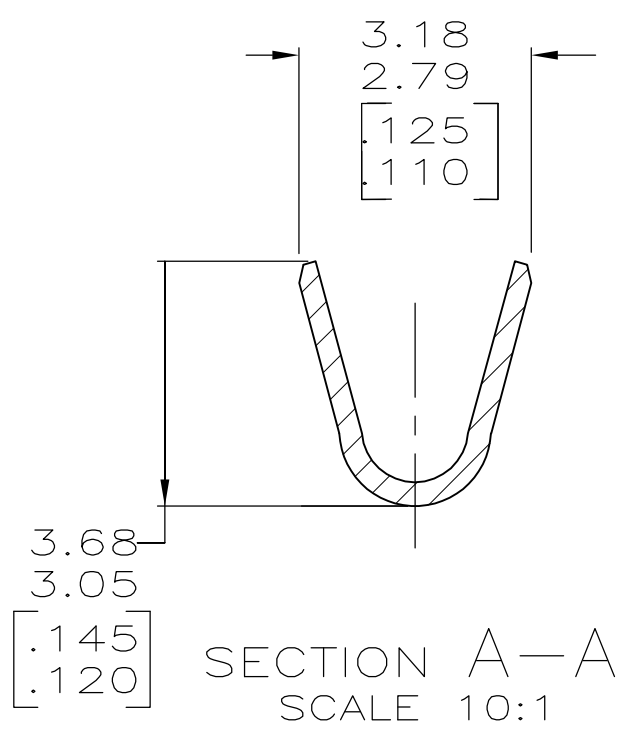
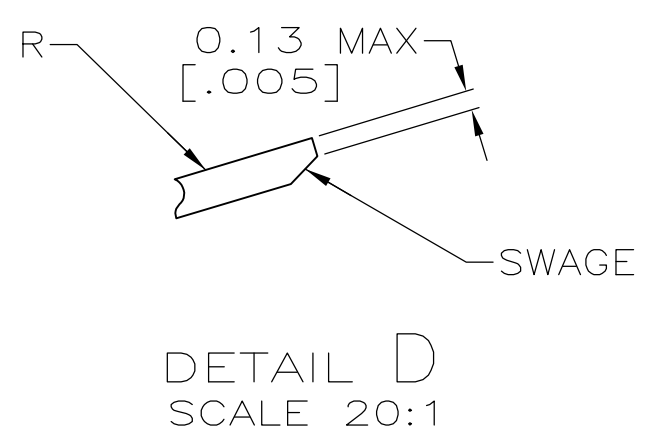
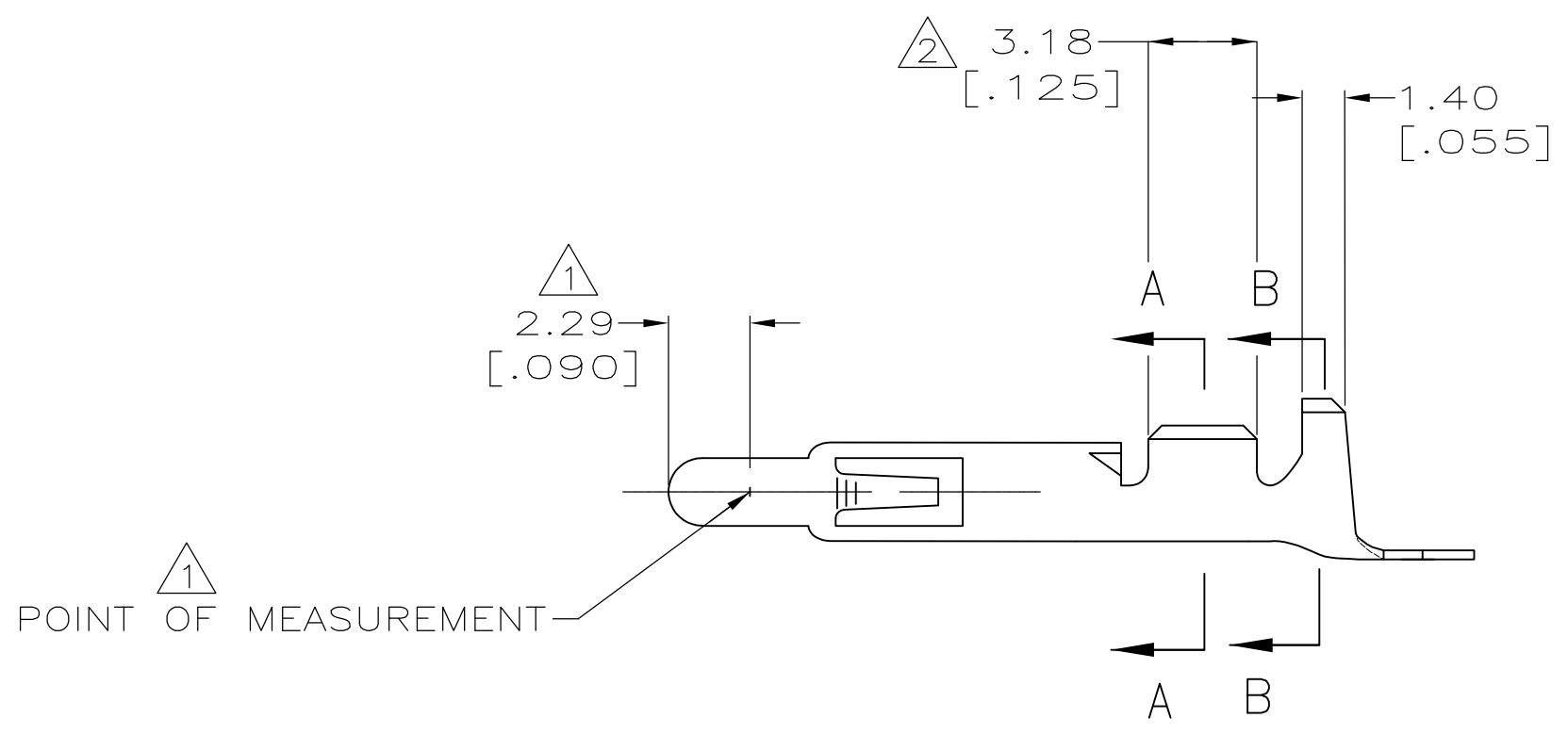
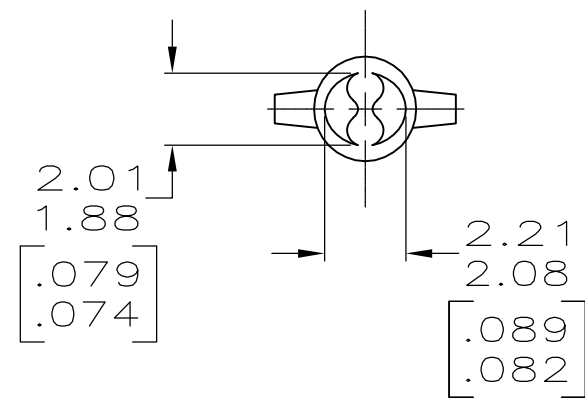

LOOSE PIECE (REF)	MATERIAL	FINISH	PART NUMBER
4 -	0.31 [.012] BE CU	PRE-TIN	350687-9
4 350705-7	0.31 [.012] BRASS	GOLD 1	350687-7
4 -	0.31 [.012] PH BRZ	GOLD 1	350687-5
350705-2	0.31 [.012] BRASS	GOLD 1 2	350687-2
350705-1	0.31 [.012] BRASS	PRE-TIN	350687-1

THIS DRAWING IS A CONTROLLED DOCUMENT.

DIMENSIONS: mm [INCHES]	TOLERANCES UNLESS OTHERWISE SPECIFIED:	DWN: K. WHITAKER 12-MAY-2000	TE Connectivity
0 PLC ± -	1 PLC ± -	CHK: K. COBLE 12-MAY-2000	
2 PLC ± 0.13 [.005]	3 PLC ± -	APVD: K. COBLE 12-MAY-2000	NAME: PIN, UNIVERSAL MATE-N-LOK™
4 PLC ± -	ANGLES ± 0°30'	PRODUCT SPEC	
MATERIAL: -		APPLICATION SPEC	SIZE: A2
FINISH: -		WEIGHT	CAGE CODE: 00779
WIRE RANGE: 20-14 AWG		CUSTOMER DRAWING	DRAWING NO: C=350687
		SCALE: 5:1	SHEET: 1 of 1
		REV: AA	RESTRICTED TO: -