

Click [here](#) for production status of specific part numbers.

MAX3483/MAX3485/ MAX3486/MAX3488/ MAX3490/MAX3491

3.3V-Powered, 10Mbps and Slew-Rate-Limited True RS-485/RS-422 Transceivers

General Description

The MAX3483, MAX3485, MAX3486, MAX3488, MAX3490, and MAX3491 are 3.3V, low-power transceivers for RS-485 and RS-422 communication. Each part contains one driver and one receiver. The MAX3483 and MAX3488 feature slew-rate-limited drivers that minimize EMI and reduce reflections caused by improperly terminated cables, allowing error-free data transmission at data rates up to 250kbps. The partially slew-rate-limited MAX3486 transmits up to 2.5Mbps. The MAX3485, MAX3490, and MAX3491 transmit at up to 10Mbps.

Drivers are short-circuit current-limited and are protected against excessive power dissipation by thermal shutdown circuitry that places the driver outputs into a high-impedance state. The receiver input has a fail-safe feature that guarantees a logic-high output if both inputs are open circuit.

The MAX3488, MAX3490, and MAX3491 feature full-duplex communication, while the MAX3483, MAX3485, and MAX3486 are designed for half-duplex communication.

Applications

- Low-Power RS-485/RS-422 Transceivers
- Telecommunications
- Transceivers for EMI-Sensitive Applications
- Industrial-Control Local Area Networks

Features

- Operate from a Single 3.3V Supply—No Charge Pump!
- Interoperable with +5V Logic
- 8ns Max Skew (MAX3485/MAX3490/MAX3491)
- Slew-Rate Limited for Errorless Data Transmission (MAX3483/MAX3488)
- 2nA Low-Current Shutdown Mode (MAX3483/MAX3485/MAX3486/MAX3491)
- -7V to +12V Common-Mode Input Voltage Range
- Allows up to 32 Transceivers on the Bus
- Full-Duplex and Half-Duplex Versions Available
- Industry Standard 75176 Pinout (MAX3483/MAX3485/MAX3486)
- Current-Limiting and Thermal Shutdown for Driver Overload Protection

Ordering Information

PART	TEMP. RANGE	PIN-PACKAGE
MAX3483CPA	0°C to +70°C	8 Plastic DIP
MAX3483CSA	0°C to +70°C	8 SO
MAX3483C/D	0°C to +70°C	Dice*
MAX3483EPA	-40°C to +85°C	8 Plastic DIP
MAX3483ESA	-40°C to +85°C	8 SO
MAX3485CPA	0°C to +70°C	8 Plastic DIP
MAX3485CSA	0°C to +70°C	8 SO
MAX3485C/D	0°C to +70°C	Dice*
MAX3485EPA	-40°C to +85°C	8 Plastic DIP
MAX3485ESA	-40°C to +85°C	8 SO

Ordering Information continued at end of data sheet.

* Contact factory for dice specifications.

Selection Table

PART NUMBER	GUARANTEED DATA RATE (Mbps)	SUPPLY VOLTAGE (V)	HALF/FULL DUPLEX	SLEW-RATE LIMITED	DRIVER/RECEIVER ENABLE	SHUTDOWN CURRENT (nA)	PIN COUNT
MAX3483	0.25	3.0 to 3.6	Half	Yes	Yes	2	8
MAX3485	10		Half	No	Yes	2	8
MAX3486	2.5		Half	Yes	Yes	2	8
MAX3488	0.25		Full	Yes	No	—	8
MAX3490	10		Full	No	No	—	8
MAX3491	10		Full	No	Yes	2	14



MAX3483/MAX3485/
 MAX3486/MAX3488/
 MAX3490/MAX3491

3.3V-Powered, 10Mbps and Slew-Rate-Limited
 True RS-485/RS-422 Transceivers

Absolute Maximum Ratings

Supply Voltage (VCC)	7V	14-Pin Plastic DIP (derate 10mW/°C above +70°C) ...	800mW
Control Input Voltage (RE, DE)	-0.3V to 7V	14-Pin SO (derate 8.33mW/°C above +70°C)	667mW
Driver Input Voltage (DI)	-0.3V to 7V	Operating Temperature Ranges	
Driver Output Voltage (A, B, Y, Z)	-7.5V to 12.5V	MAX34__C_	0°C to +70°C
Receiver Input Voltage (A, B)	-7.5V to 12.5V	MAX34__E_	-40°C to +85°C
Receiver Output Voltage (RO)	-0.3V to (V _{CC} + 0.3V)	Junction Temperature	+160°C
Continuous Power Dissipation (T _A = +70°C)		Storage Temperature Range	-65°C to +160°C
8-Pin Plastic DIP (derate 9.09mW/°C above +70°C) ..	727mW	Lead Temperature (soldering, 10sec)	+300°C
8-Pin SO (derate 5.88mW/°C above +70°C)	471mW		

Package Information

14 SOIC

PACKAGE CODE	S14+1
Outline Number	21-0041
Land Pattern Number	90-0112
Thermal Resistance, Single-Layer Board:	
Junction to Ambient (θ _{JA})	120
Junction to Case (θ _{JA})	37
Thermal Resistance, Four-Layer Board:	
Junction to Ambient (θ _{JA})	84
Junction to Case (θ _{JA})	34

For the latest package outline information and land patterns (footprints), go to www.maximintegrated.com/packages. Note that a "+", "#", or "-" in the package code indicates RoHS status only. Package drawings may show a different suffix character, but the drawing pertains to the package regardless of RoHS status.

Package thermal resistances were obtained using the method described in JEDEC specification JESD51-7, using a four-layer board. For detailed information on package thermal considerations, refer to www.maximintegrated.com/thermal-tutorial.

MAX3483/MAX3485/
MAX3486/MAX3488/
MAX3490/MAX3491

3.3V-Powered, 10Mbps and Slew-Rate-Limited
True RS-485/RS-422 Transceivers

DC Electrical Characteristics

($V_{CC} = 3.3V \pm 0.3V$, $T_A = T_{MIN}$ to T_{MAX} , unless otherwise noted. Typical values are at $T_A = +25^\circ C$)

PARAMETER	SYMBOL	CONDITIONS		MIN	TYP	MAX	UNITS
Differential Driver Output	V_{OD}	$R_L = 100\Omega$ (RS-422), Figure 4		2.0			V
		$R_L = 54\Omega$ (RS-485), Figure 4		1.5			
		$R_L = 60\Omega$ (RS-485), $V_{CC} = 3.3V$, Figure 5		1.5			
Change in Magnitude of Driver Differential Output Voltage for Complementary Output States (Note 1)	ΔV_{OD}	$R_L = 54\Omega$ or 100Ω , Figure 4				0.2	V
Driver Common-Mode Output Voltage	V_{OC}	$R_L = 54\Omega$ or 100Ω , Figure 4				3	V
Change in Magnitude of Common-Mode Output Voltage (Note 1)	ΔV_{OC}	$R_L = 54\Omega$ or 100Ω , Figure 4				0.2	V
Input High Voltage	V_{IH}	DE, DI, RE		2.0			V
Input Low Voltage	V_{IL}	DE, DI, RE				0.8	V
Logic Input Current	I_{IN1}	DE, DI, RE				± 2	μA
Input Current (A, B)	I_{IN2}	DE = 0V, $V_{CC} = 0V$ or $3.6V$	$V_{IN} = 12V$			1.0	mA
			$V_{IN} = -7V$			-0.8	
Output Leakage (Y, Z)	I_O	DE = 0V, RE = 0V, $V_{CC} = 0V$ or $3.6V$, MAX3491	$V_{OUT} = 12V$			20	μA
			$V_{OUT} = -7V$			-20	
Output Leakage (Y, Z) in Shutdown Mode	I_O	DE = 0V, RE = V_{CC} , $V_{CC} = 0V$ or $3.6V$, MAX3491	$V_{OUT} = 12V$			1	μA
			$V_{OUT} = -7V$			-1	
Receiver Differential Threshold Voltage	V_{TH}	$-7V \leq V_{CM} \leq 12V$		-0.2		0.2	V
Receiver Input Hysteresis	ΔV_{TH}	$V_{CM} = 0V$			50		mV
Receiver Output High Voltage	V_{OH}	$I_{OUT} = -1.5mA$, $V_{ID} = 200mV$, Figure 6		$V_{CC} - 0.4$			V
Receiver Output Low Voltage	V_{OL}	$I_{OUT} = 2.5mA$, $V_{ID} = 200mV$, Figure 6				0.4	V
Three-State (High Impedance) Output Current at Receiver	I_{OZR}	$V_{CC} = 3.6V$, $0V \leq V_{OUT} \leq V_{CC}$				± 1	μA
Receiver Input Resistance	R_{IN}	$-7V \leq V_{CM} \leq 12V$		12			k Ω
Supply Current	I_{CC}	No load, DI = 0V or V_{CC}	DE = V_{CC} , RE = 0V or V_{CC}		1.1	2.2	mA
			DE = 0V, RE = 0V		0.95	1.9	
Supply Current in Shutdown Mode	I_{SHDN}	DE = 0V, RE = V_{CC} , DI = V_{CC} or 0V			0.002	1	μA
Driver Short-Circuit Output Current	I_{OSD}	$V_{OUT} = -7V$				-250	mA
		$V_{OUT} = 12V$				250	
Receiver Short-Circuit Output Current	I_{OSR}	$0V \leq V_{RO} \leq V_{CC}$		± 8		± 60	mA

MAX3483/MAX3485/
MAX3486/MAX3488/
MAX3490/MAX3491

3.3V-Powered, 10Mbps and Slew-Rate-Limited
True RS-485/RS-422 Transceivers

Driver Switching Characteristics—MAX3485, MAX3490, and MAX3491

($V_{CC} = 3.3V$, $T_A = +25^\circ C$)

PARAMETER	SYMBOL	CONDITIONS	MIN	TYP	MAX	UNITS
Driver Differential Output Delay	t_{DD}	$R_L = 60\Omega$, Figure 7	1	22	35	ns
Driver Differential Output Transition Time	t_{TD}	$R_L = 60\Omega$, Figure 7	3	8	25	ns
Driver Propagation Delay, Low-to-High Level	t_{PLH}	$R_L = 27\Omega$, Figure 8	7	22	35	ns
Driver Propagation Delay, High-to-Low Level	t_{PHL}	$R_L = 27\Omega$, Figure 8	7	22	35	ns
$ t_{PLH} - t_{PHL} $ Driver Propagation Delay Skew (Note 2)	t_{PDS}	$R_L = 27\Omega$, Figure 8			8	ns
DRIVER OUTPUT ENABLE/DISABLE TIMES (MAX3485/MAX3491 only)						
Driver Output Enable Time to Low Level	t_{PZL}	$R_L = 110\Omega$, Figure 10		45	90	ns
Driver Output Enable Time to High Level	t_{PZH}	$R_L = 110\Omega$, Figure 9		45	90	ns
Driver Output Disable Time from High Level	t_{PHZ}	$R_L = 110\Omega$, Figure 9		40	80	ns
Driver Output Disable Time from Low Level	t_{PLZ}	$R_L = 110\Omega$, Figure 10		40	80	ns
Driver Output Enable Time from Shutdown to Low Level	t_{PSL}	$R_L = 110\Omega$, Figure 10		650	900	ns
Driver Output Enable Time from Shutdown to High Level	t_{PSH}	$R_L = 110\Omega$, Figure 9		650	900	ns

Driver Switching Characteristics—MAX3486

($V_{CC} = 3.3V$, $T_A = +25^\circ C$)

PARAMETER	SYMBOL	CONDITIONS	MIN	TYP	MAX	UNITS
Driver Differential Output Delay	t_{DD}	$R_L = 60\Omega$, Figure 7	24	48	70	ns
Driver Differential Output Transition Time	t_{TD}	$R_L = 60\Omega$, Figure 7	15	35	60	ns
Driver Propagation Delay, Low-to-High Level	t_{PLH}	$R_L = 27\Omega$, Figure 8	20	48	70	ns
Driver Propagation Delay, High-to-Low Level	t_{PHL}	$R_L = 27\Omega$, Figure 8	20	48	70	ns
$ t_{PLH} - t_{PHL} $ Driver Propagation Delay Skew (Note 2)	t_{PDS}	$R_L = 27\Omega$, Figure 8			11	ns
Driver Output Enable Time to Low Level	t_{PZL}	$R_L = 110\Omega$, Figure 10		55	100	ns
Driver Output Enable Time to High Level	t_{PZH}	$R_L = 110\Omega$, Figure 9		55	100	ns
Driver Output Disable Time from High Level	t_{PHZ}	$R_L = 110\Omega$, Figure 9		45	80	ns
Driver Output Disable Time from Low Level	t_{PLZ}	$R_L = 110\Omega$, Figure 10		45	80	ns
Driver Output Enable Time from Shutdown to Low Level	t_{PSL}	$R_L = 110\Omega$, Figure 10		700	1000	ns
Driver Output Enable Time from Shutdown to High Level	t_{PSH}	$R_L = 110\Omega$, Figure 9		700	1000	ns

MAX3483/MAX3485/
MAX3486/MAX3488/
MAX3490/MAX3491

3.3V-Powered, 10Mbps and Slew-Rate-Limited
True RS-485/RS-422 Transceivers

Driver Switching Characteristics—MAX3483 and MAX3488

($V_{CC} = 3.3V$, $T_A = +25^\circ C$)

PARAMETER	SYMBOL	CONDITIONS	MIN	TYP	MAX	UNITS
Driver Differential Output Delay	t_{DD}	$R_L = 60\Omega$, Figure 7	600	900	1400	ns
Driver Differential Output Transition Time	t_{TD}	$R_L = 60\Omega$, Figure 7	400	700	1200	ns
Driver Propagation Delay, Low-to-High Level	t_{PLH}	$R_L = 27\Omega$, Figure 8	700	1000	1500	ns
Driver Propagation Delay, High-to-Low Level	t_{PHL}	$R_L = 27\Omega$, Figure 8	700	1000	1500	ns
$ t_{PLH} - t_{PHL} $ Driver Propagation Delay Skew (Note 2)	t_{PDS}	$R_L = 27\Omega$, Figure 8		100		ns
DRIVER OUTPUT ENABLE/DISABLE TIMES (MAX3485/MAX3491 only)						
Driver Output Enable Time to Low Level	t_{PZL}	$R_L = 110\Omega$, Figure 10		900	1300	ns
Driver Output Enable Time to High Level	t_{PZH}	$R_L = 110\Omega$, Figure 9		600	800	ns
Driver Output Disable Time from High Level	t_{PHZ}	$R_L = 110\Omega$, Figure 9		50	80	ns
Driver Output Disable Time from Low Level	t_{PLZ}	$R_L = 110\Omega$, Figure 10		50	80	ns
Driver Output Enable Time from Shutdown to Low Level	t_{PSL}	$R_L = 110\Omega$, Figure 10		1.9	2.7	ns
Driver Output Enable Time from Shutdown to High Level	t_{PSH}	$R_L = 110\Omega$, Figure 9		2.2	3.0	ns

Receiver Switching Characteristics

($V_{CC} = 3.3V$, $T_A = +25^\circ C$)

PARAMETER	SYMBOL	CONDITIONS	MIN	TYP	MAX	UNITS
Time to Shutdown	t_{SHDN}	MAX3483/MAX3485/MAX3486/MAX3491 only (Note 3)	80	190	300	ns
Receiver Propagation Delay, Low-to-High Level	t_{RPLH}	$V_{ID} = 0V$ to $3.0V$, $C_L = 15pF$, Figure 11	25	65	90	ns
		MAX3483/MAX3488	25	75	120	
Receiver Propagation Delay, High-to-Low Level	t_{RPHL}	$V_{ID} = 0V$ to $3.0V$, $C_L = 15pF$, Figure 11	25	65	90	ns
		MAX3483/MAX3488	25	75	120	
$ t_{PLH} - t_{PHL} $ Receiver Propagation Delay Skew	t_{RPDS}	$V_{ID} = 0V$ to $3.0V$, $C_L = 15pF$, Figure 11			10	ns
		MAX3483/MAX3488			20	
Receiver Output Enable Time to Low Level	t_{PRZL}	$C_L = 15pF$, Figure 12, MAX3483/MAX3485/MAX3486/MAX3491 only		25	50	ns
Receiver Output Enable Time to High Level	t_{PRZH}	$C_L = 15pF$, Figure 12, MAX3483/MAX3485/MAX3486/MAX3491 only		25	50	ns
Receiver Output Disable Time from High Level	t_{PRHZ}	$C_L = 15pF$, Figure 12, MAX3483/MAX3485/MAX3486/MAX3491 only		25	45	ns
Receiver Output Disable Time from Low Level	t_{PRLZ}	$C_L = 15pF$, Figure 12, MAX3483/MAX3485/MAX3486/MAX3491 only		25	45	ns
Receiver Output Enable Time from Shutdown to Low Level	t_{PRSL}	$C_L = 15pF$, Figure 12, MAX3483/MAX3485/MAX3486/MAX3491 only		720	1400	ns
Receiver Output Enable Time from Shutdown to High Level	t_{PRSH}	$C_L = 15pF$, Figure 12, MAX3483/MAX3485/MAX3486/MAX3491 only		720	1400	ns

Note 1: ΔV_{OD} and ΔV_{OC} are the changes in V_{OD} and V_{OC} , respectively, when the DI input changes state.

Note 2: Measured on $|t_{PLH}(Y) - t_{PHL}(Y)|$ and $|t_{PLH}(Z) - t_{PHL}(Z)|$.

Note 3: The transceivers are put into shutdown by bringing RE high and DE low. If the inputs are in this state for less than 80ns, the parts are guaranteed not to enter shutdown. If the inputs are in this state for at least 300ns, the parts are guaranteed to have entered shutdown. See *Low-Power Shutdown Mode* section.

MAX3483/MAX3485/
MAX3486/MAX3488/
MAX3490/MAX3491

3.3V-Powered, 10Mbps and Slew-Rate-Limited
True RS-485/RS-422 Transceivers

Typical Operating Characteristics

($V_{CC} = 3.3V$, $T_A = +25^\circ C$, unless otherwise noted.)

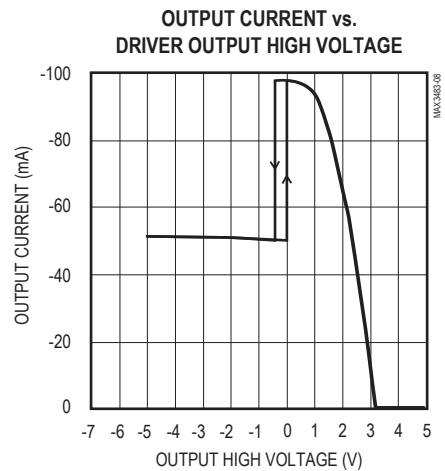
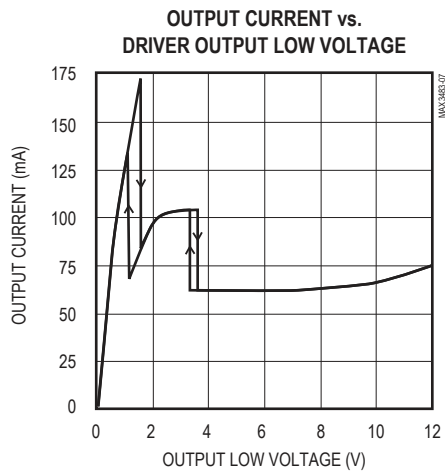
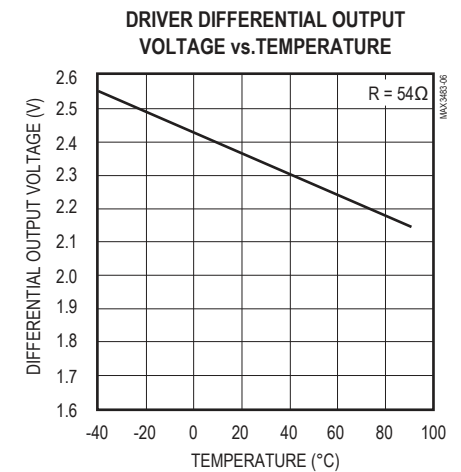
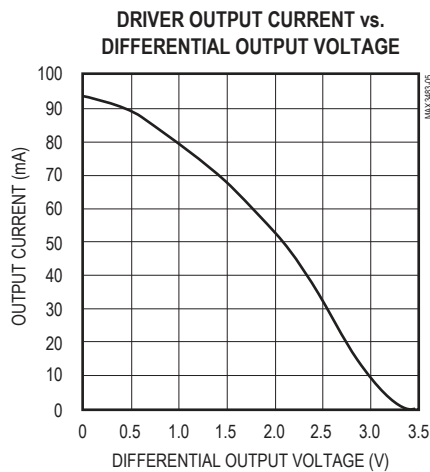
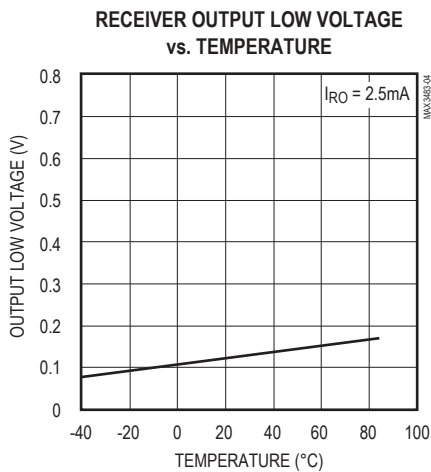
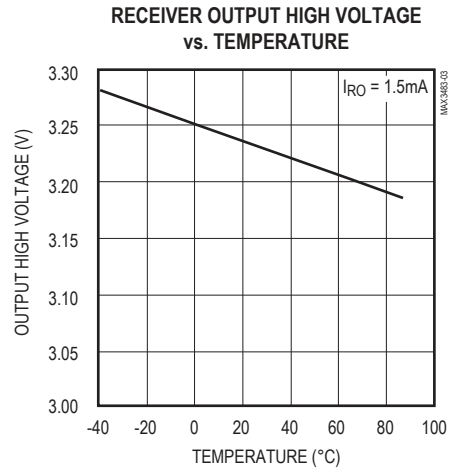
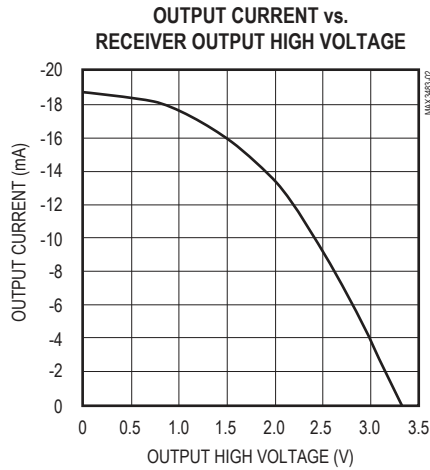
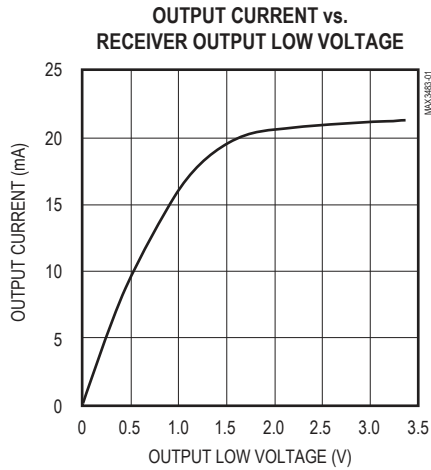

MAX3483/MAX3485/
MAX3486/MAX3488/
MAX3490/MAX3491

3.3V-Powered, 10Mbps and Slew-Rate-Limited
True RS-485/RS-422 Transceivers

Typical Operating Characteristics (continued)

($V_{CC} = 3.3V$, $T_A = +25^\circ C$, unless otherwise noted.)

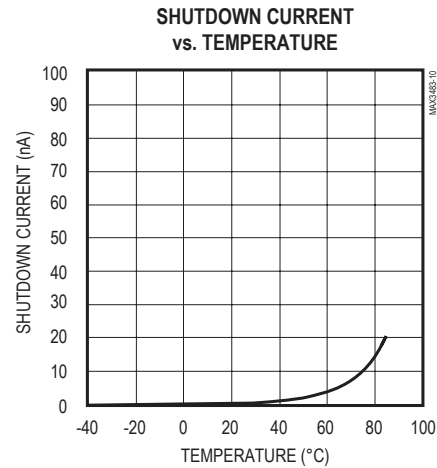
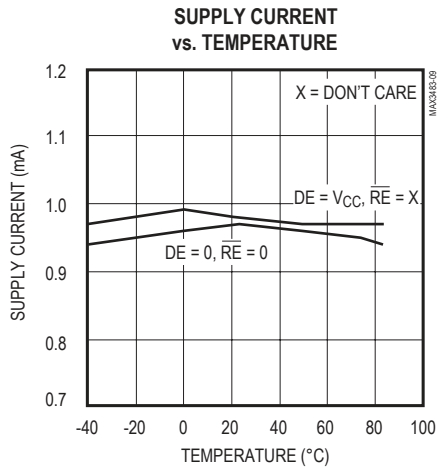

Pin Description

PIN			NAME	FUNCTION
MAX3483/ MAX3485/ MAX3486	MAX3488/ MAX3490	MAX3491		
1	2	2	RO	Receiver Output. If $A > B$ by 200mV, RO will be high; if $A < B$ by 200mV, RO will be low.
2	—	3	\overline{RE}	Receiver Output Enable. RO is enabled when \overline{RE} is low; RO is high impedance when \overline{RE} is high. If \overline{RE} is high and DE is low, the device will enter a low-power shutdown mode.
3	—	4	DE	Driver Output Enable. The driver outputs are enabled by bringing DE high. They are high impedance when DE is low. If \overline{RE} is high and DE is low, the device will enter a low-power shutdown mode. If the driver outputs are enabled, the parts function as line drivers. While they are high impedance, they function as line receivers if \overline{RE} is low.
4	3	5	DI	Driver Input. A low on DI forces output Y low and output Z high. Similarly, a high on DI forces output Y high and output Z low.
5	4	6, 7	GND	Ground
—	5	9	Y	Noninverting Driver Output
—	6	10	Z	Inverting Driver Output
6	—	—	A	Noninverting Receiver Input and Noninverting Driver Output
—	8	12	A	Noninverting Receiver Input
7	—	—	B	Inverting Receiver Input and Inverting Driver Output
—	7	11	B	Inverting Receiver Input
8	1	13, 14	V_{CC}	Positive Supply: $3.0V \leq V_{CC} \leq 3.6V$
—	—	1, 8	N.C.	No Connect—not internally connected

MAX3483/MAX3485/
MAX3486/MAX3488/
MAX3490/MAX3491

3.3V-Powered, 10Mbps and Slew-Rate-Limited
True RS-485/RS-422 Transceivers

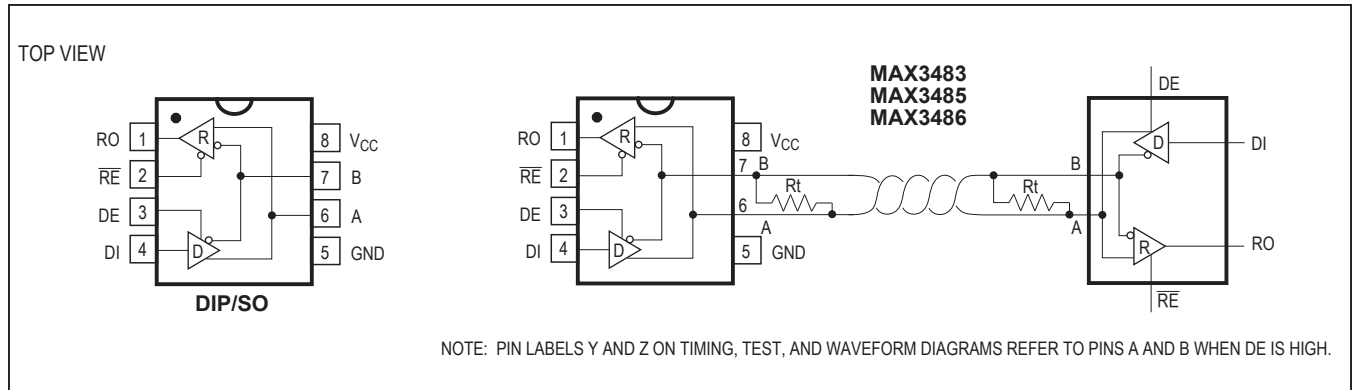

Figure 1. MAX3483/MAX3485/MAX3486 Pin Configuration and Typical Operating Circuit

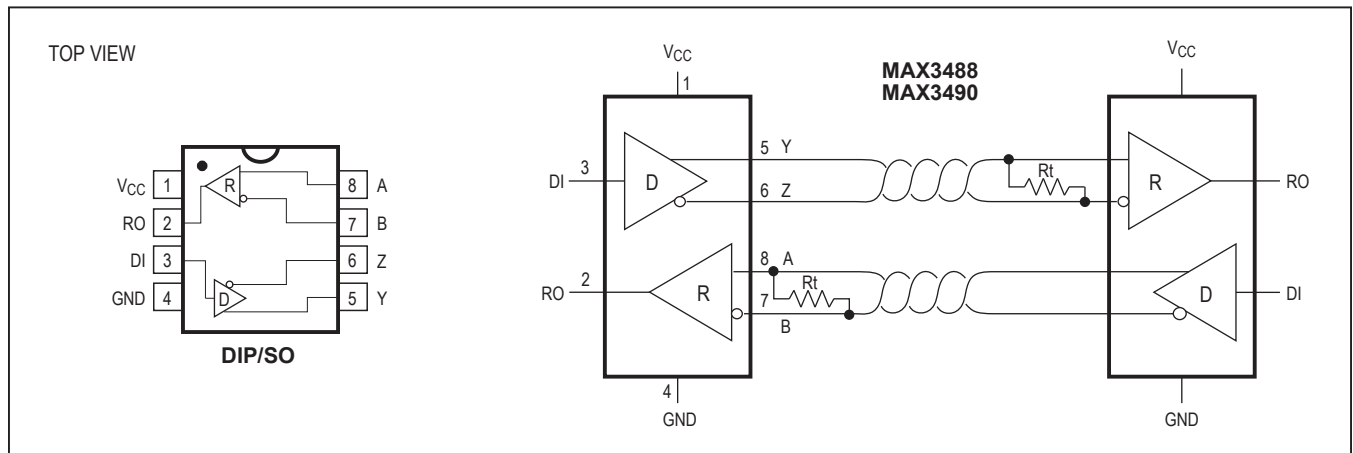

Figure 2. MAX3488/MAX3490 Pin Configuration and Typical Operating Circuit

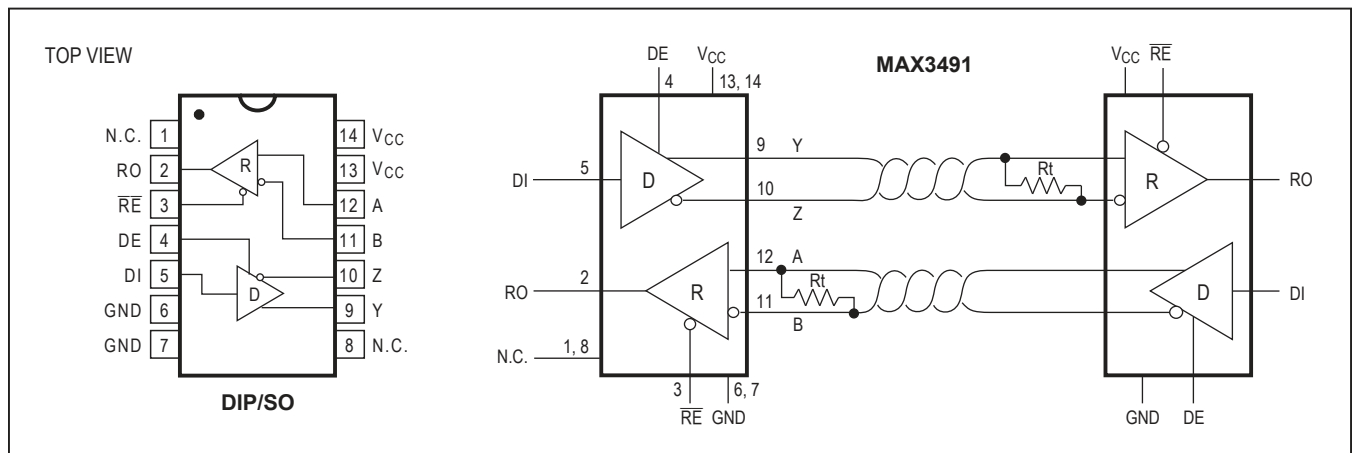

Figure 3. MAX3491 Pin Configuration and Typical Operating Circuit

MAX3483/MAX3485/
MAX3486/MAX3488/
MAX3490/MAX3491

3.3V-Powered, 10Mbps and Slew-Rate-Limited
True RS-485/RS-422 Transceivers

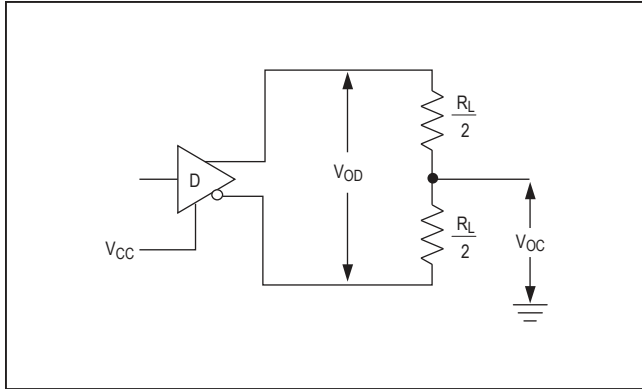

Figure 4. Driver V_{OD} and V_{OC}

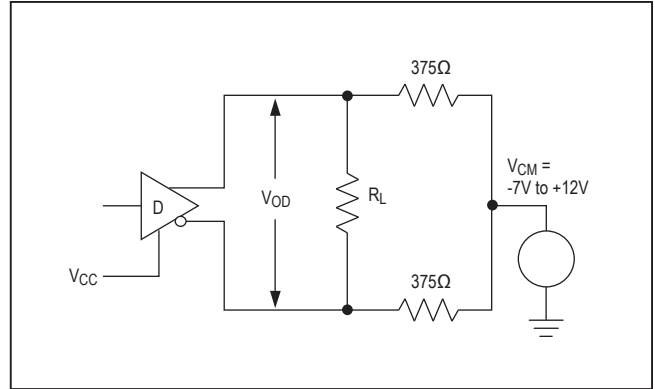

Figure 5. Driver V_{OD} with Varying Common-Mode Voltage

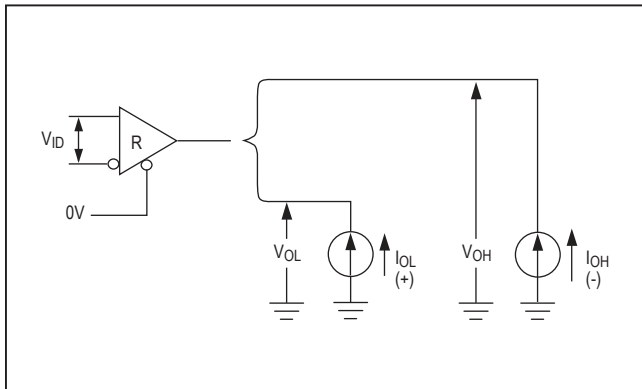

Figure 6. Receiver V_{OH} and V_{OL}

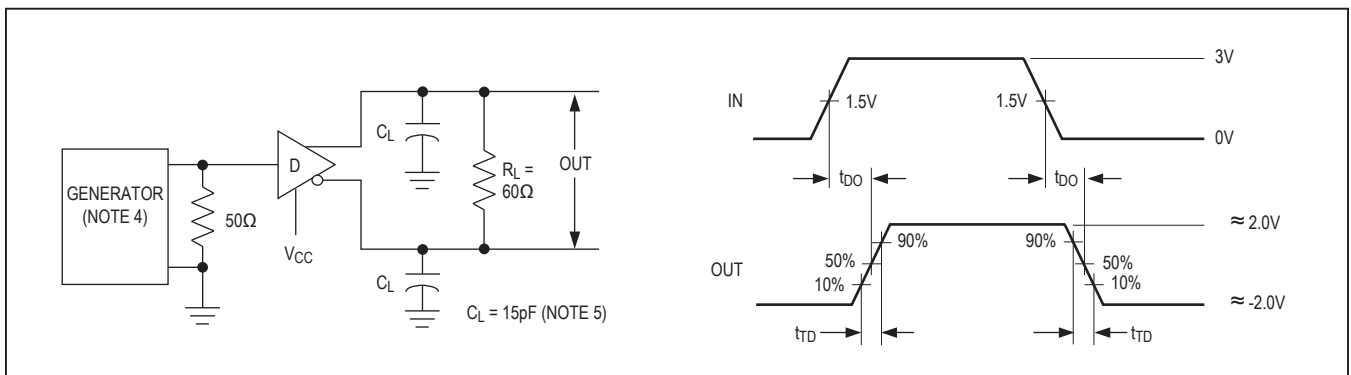

Figure 7. Driver Differential Output Delay and Transition Times

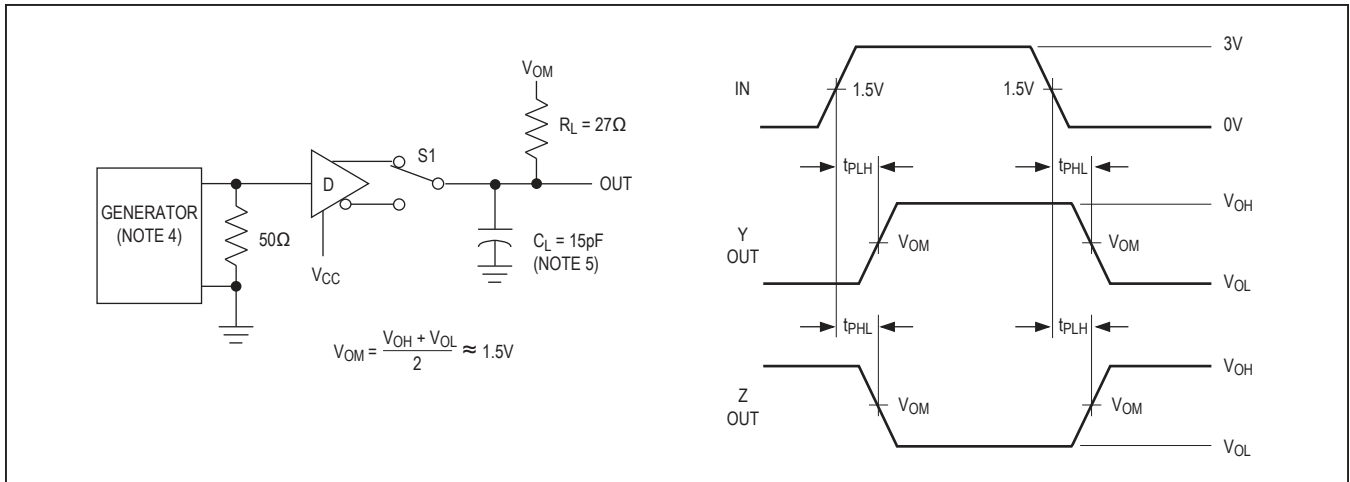

Figure 8. Driver Propagation Times

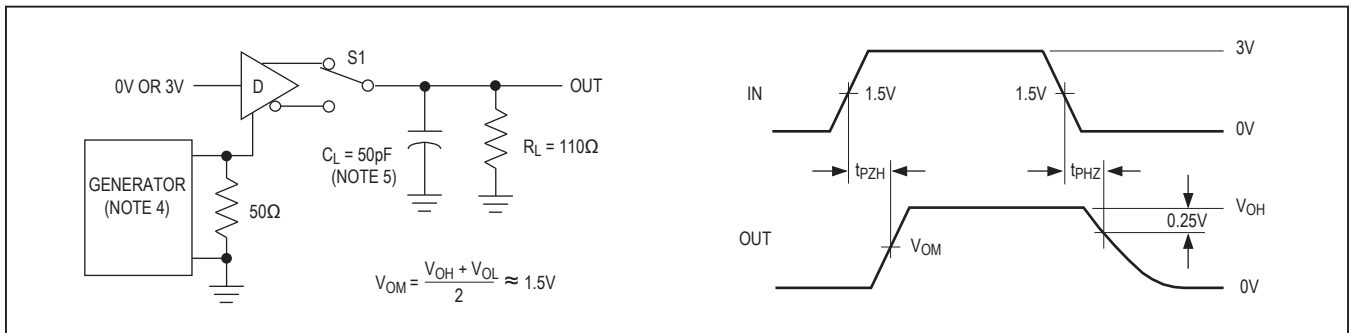

Figure 9. Driver Enable and Disable Times (tPZH, tPSH, tPHZ)

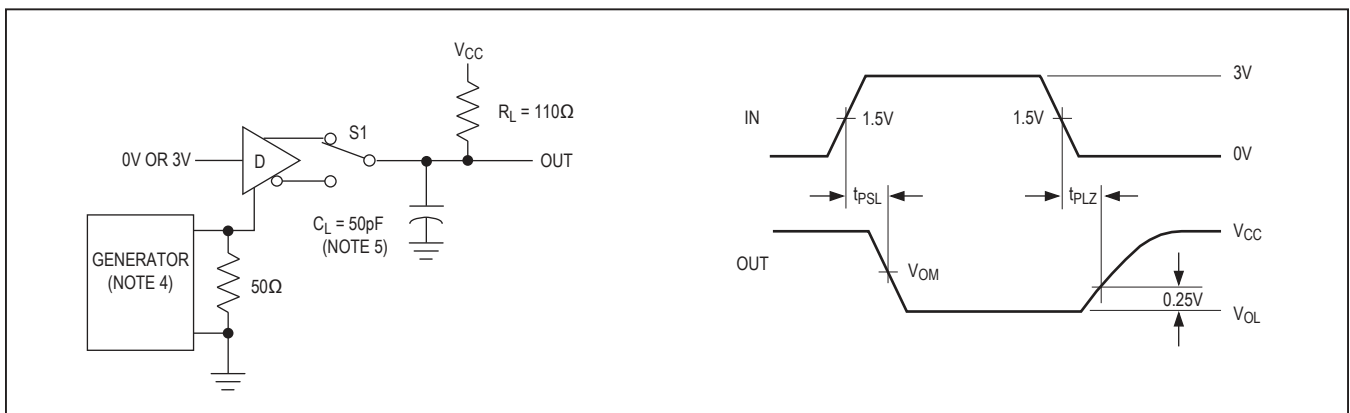

Figure 10. Driver Enable and Disable Times (tPZL, tPSL, tPLZ)

MAX3483/MAX3485/
MAX3486/MAX3488/
MAX3490/MAX3491

3.3V-Powered, 10Mbps and Slew-Rate-Limited
True RS-485/RS-422 Transceivers

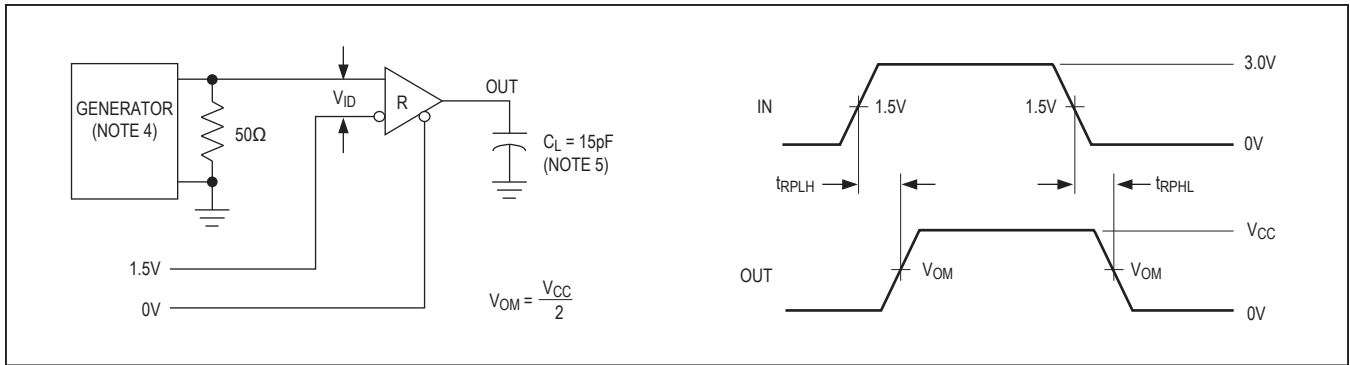

Figure 11. Receiver Propagation Delay

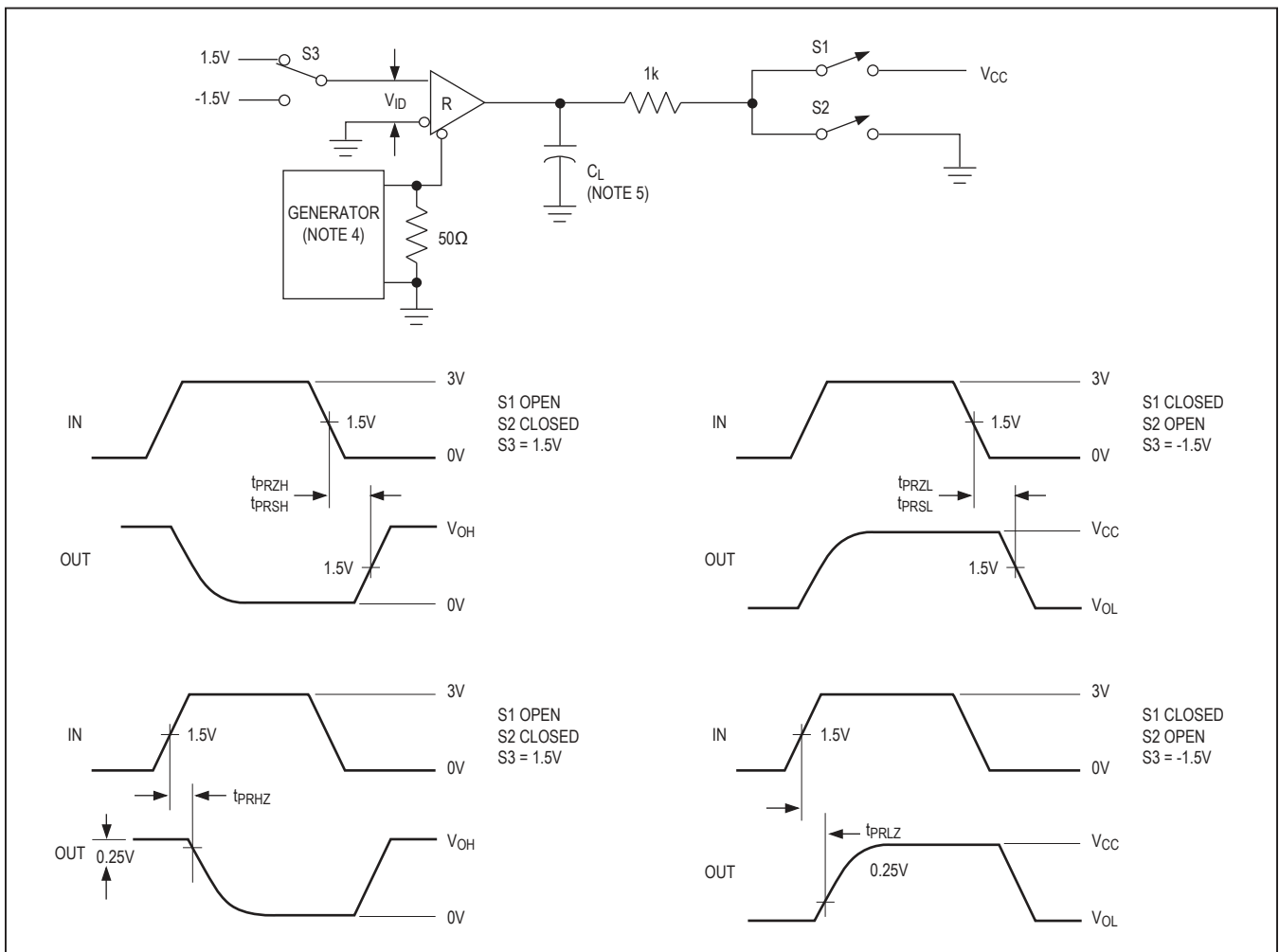

Figure 12. Receiver Enable and Disable Times

Note 4: The input pulse is supplied by a generator with the following characteristics: PRR = 250kHz, 50% duty cycle, $t_r \leq 6.0\text{ns}$, $Z_0 = 50\Omega$.

Note 5: C_L includes probe and stray capacitance.

MAX3483/MAX3485/
MAX3486/MAX3488/
MAX3490/MAX3491

3.3V-Powered, 10Mbps and Slew-Rate-Limited
True RS-485/RS-422 Transceivers

Function Tables

Devices with Receiver/Driver Enable
(MAX3483/MAX3485/MAX3486/MAX3491)

Table 1. Transmitting

INPUTS			OUTPUTS		MODE
\overline{RE}	DE	DI	B*	A*	
X	1	1	0	1	Normal
X	1	0	1	0	Normal
0	0	X	High-Z	High-Z	Normal
1	0	X	High-Z	High-Z	Shutdown

* B and A outputs are Z and Y, respectively, for full-duplex part (MAX3491).

X = Don't care; High-Z = High impedance

Table 2. Receiving

INPUTS			OUTPUTS	MODE
\overline{RE}	DE	A, B	B*	
0	0*	$\geq +0.2V$	1	Normal
0	0*	$\leq -0.2V$	0	Normal
0	0*	Inputs Open	1	Normal
1	0	X	High-Z	Shutdown

* DE is a "don't care" (x) for the full-duplex part (MAX3491).

X = Don't care; High-Z = High impedance

Devices without Receiver/Driver Enable
(MAX3488/MAX3490)

Table 3. Transmitting Table 4. Receiving

INPUT	OUTPUTS	
DI	Z	Y
1	0	1
0	1	0

INPUTS	OUTPUT
A, B	RO
$\geq +0.2V$	1
$\leq -0.2V$	0
Inputs Open	1

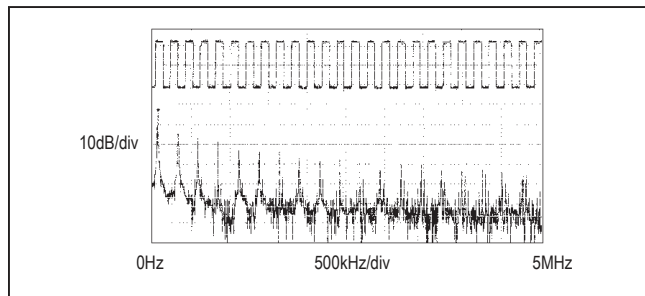

Figure 13. Driver Output Waveform and FFT Plot of MAX3485/MAX3490/MAX3491 Transmitting a 125kHz Signal

Applications Information

The MAX3483/MAX3485/MAX3486/MAX3488/MAX3490/MAX3491 are low-power transceivers for RS-485 and RS-422 communications. The MAX3483 and MAX3488 can transmit and receive at data rates up to 250kbps, the MAX3486 at up to 2.5Mbps, and the MAX3485/MAX3490/MAX3491 at up to 10Mbps. The MAX3488/MAX3490/MAX3491 are full-duplex transceivers, while the MAX3483/MAX3485/MAX3486 are half-duplex. Driver Enable (DE) and Receiver Enable (\overline{RE}) pins are included on the MAX3483/MAX3485/MAX3486/MAX3491. When disabled, the driver and receiver outputs are high impedance.

Reduced EMI and Reflections
(MAX3483/MAX3486/MAX3488)

The MAX3483/MAX3488 are slew-rate limited, minimizing EMI and reducing reflections caused by improperly terminated cables. Figure 13 shows both the driver output waveform of a MAX3485/MAX3490/MAX3491 transmitting a 125kHz signal and the Fourier analysis of that waveform. High-frequency harmonics with large amplitudes are evident. Figure 14 shows the same information, but for the slew-rate-limited MAX3483/MAX3488 transmitting the same signal. The high-frequency harmonics have much lower amplitudes, and the potential for EMI is significantly reduced.

Low-Power Shutdown Mode
(MAX3483/MAX3485/MAX3486/MAX3491)

A low-power shutdown mode is initiated by bringing both \overline{RE} high and DE low. The devices will not shut down unless both the driver and receiver are disabled (high impedance). In shutdown, the devices typically draw only 2nA of supply current.

For these devices, the t_{PSH} and t_{PSL} enable times assume the part was in the low-power shutdown mode; the t_{PZH} and t_{PZL} enable times assume the receiver or driver was disabled, but the part was not shut down.

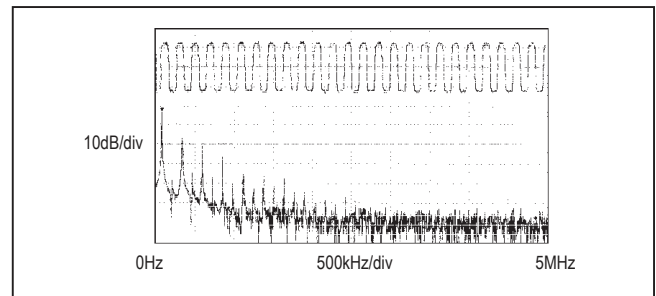

Figure 14. Driver Output Waveform and FFT Plot of MAX3483/MAX3488 Transmitting a 125kHz Signal

MAX3483/MAX3485/
MAX3486/MAX3488/
MAX3490/MAX3491

3.3V-Powered, 10Mbps and Slew-Rate-Limited
True RS-485/RS-422 Transceivers

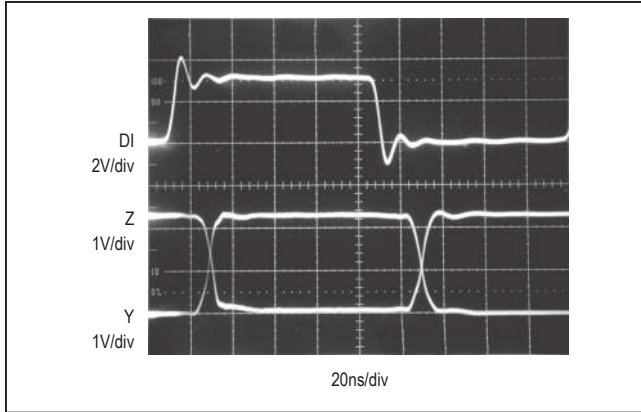

Figure 15. MAX3485/MAX3490/MAX3491 Driver Propagation Delay

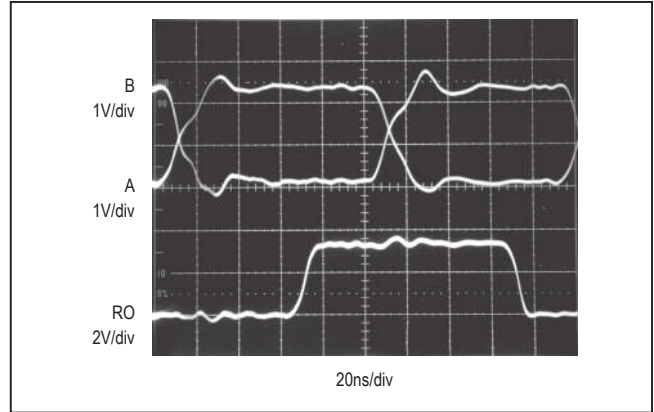

Figure 16. MAX3485/MAX3490/MAX3491 Receiver Propagation Delay Driven by External RS-485 Device

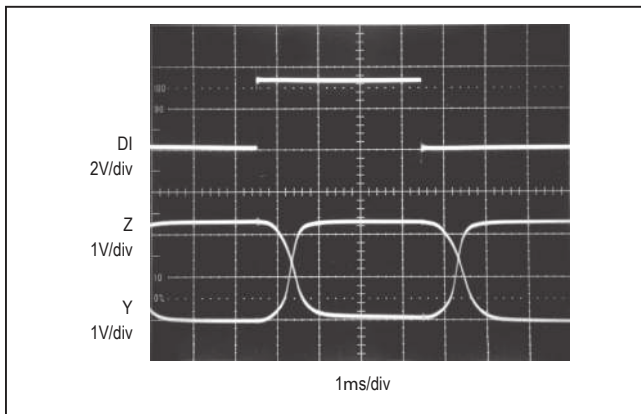

Figure 17. MAX3483/MAX3488 Driver Propagation Delay

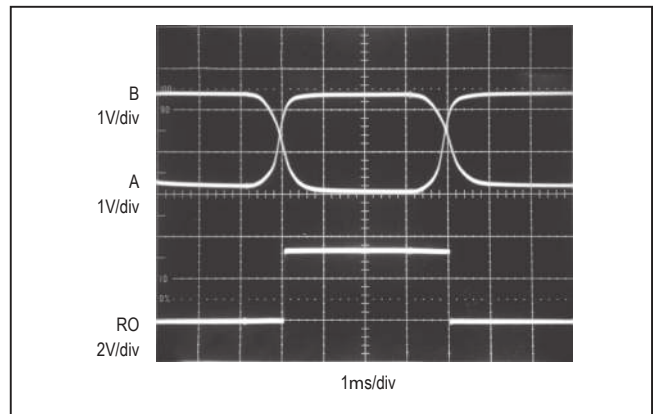

Figure 18. MAX3483/MAX3488 Receiver Propagation Delay

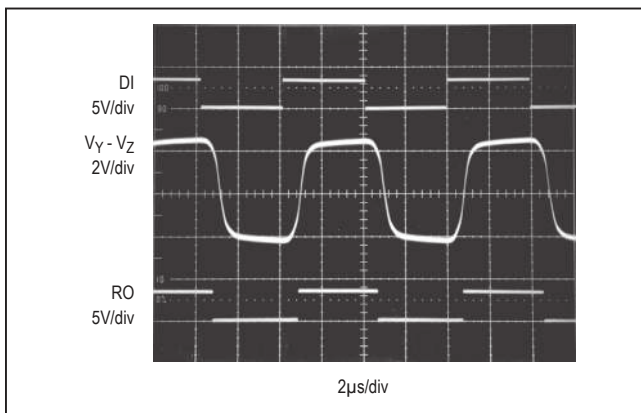

Figure 19. MAX3483/MAX3488 System Differential Voltage at 125kHz Driving 4000 ft of Cable

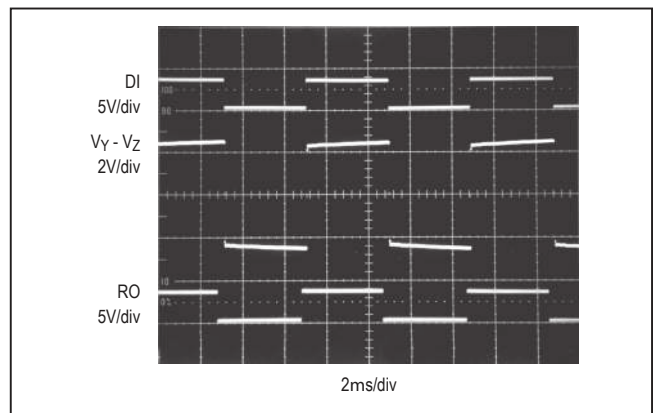

Figure 20. MAX3485/MAX3490/MAX3491 System Differential Voltage at 125kHz Driving 4000 ft of Cable

MAX3483/MAX3485/
MAX3486/MAX3488/
MAX3490/MAX3491

3.3V-Powered, 10Mbps and Slew-Rate-Limited
True RS-485/RS-422 Transceivers

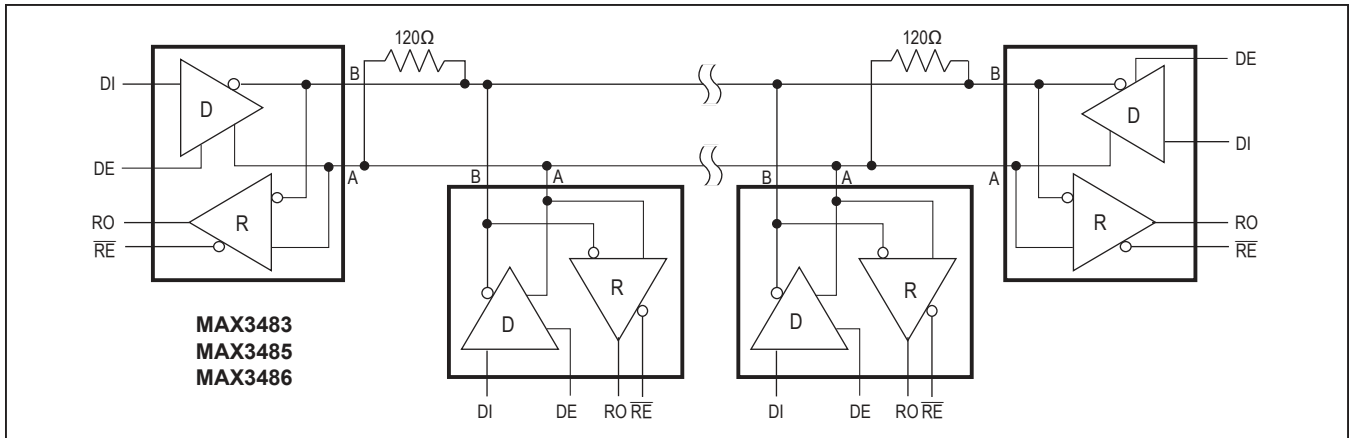

Figure 21. MAX3483/MAX3485/MAX3486 Typical RS-485 Network

Driver Output Protection

Excessive output current and power dissipation caused by faults or by bus contention are prevented by two mechanisms. A foldback current limit on the output stage provides immediate protection against short circuits over the whole common-mode voltage range (see *Typical Operating Characteristics*). In addition, a thermal shut-down circuit forces the driver outputs into a high-impedance state if the die temperature rises excessively.

Propagation Delay

Figures 15–18 show the typical propagation delays. Skew time is simply the difference between the low-to-high and high-to-low propagation delay. Small driver/receiver skew times help maintain a symmetrical mark-space ratio (50% duty cycle).

The receiver skew time, $|t_{\text{PRLH}} - t_{\text{PRHL}}|$, is under 10ns (20ns for the MAX3483/MAX3488). The driver skew times are 8ns for the MAX3485/MAX3490/MAX3491, 11ns for the MAX3486, and typically under 100ns for the MAX3483/MAX3488.

Line Length vs. Data Rate

The RS-485/RS-422 standard covers line lengths up to 4000 feet. For line lengths greater than 4000 feet, see Figure 23.

Figures 19 and 20 show the system differential voltage for parts driving 4000 feet of 26AWG twisted-pair wire at 125kHz into 120Ω loads.

Typical Applications

The MAX3483, MAX3485, MAX3486, MAX3488, MAX3490, and MAX3491 transceivers are designed for bidirectional data communications on multipoint bus transmission lines. Figures 21 and 22 show typical network applications circuits. These parts can also be used as line repeaters, with cable lengths longer than 4000 feet, as shown in Figure 23.

To minimize reflections, the line should be terminated at both ends in its characteristic impedance, and stub lengths off the main line should be kept as short as possible. The slew-rate-limited MAX3483/MAX3488 and the partially slew-rate-limited MAX3486 are more tolerant of imperfect termination.

MAX3483/MAX3485/
 MAX3486/MAX3488/
 MAX3490/MAX3491

3.3V-Powered, 10Mbps and Slew-Rate-Limited
 True RS-485/RS-422 Transceivers

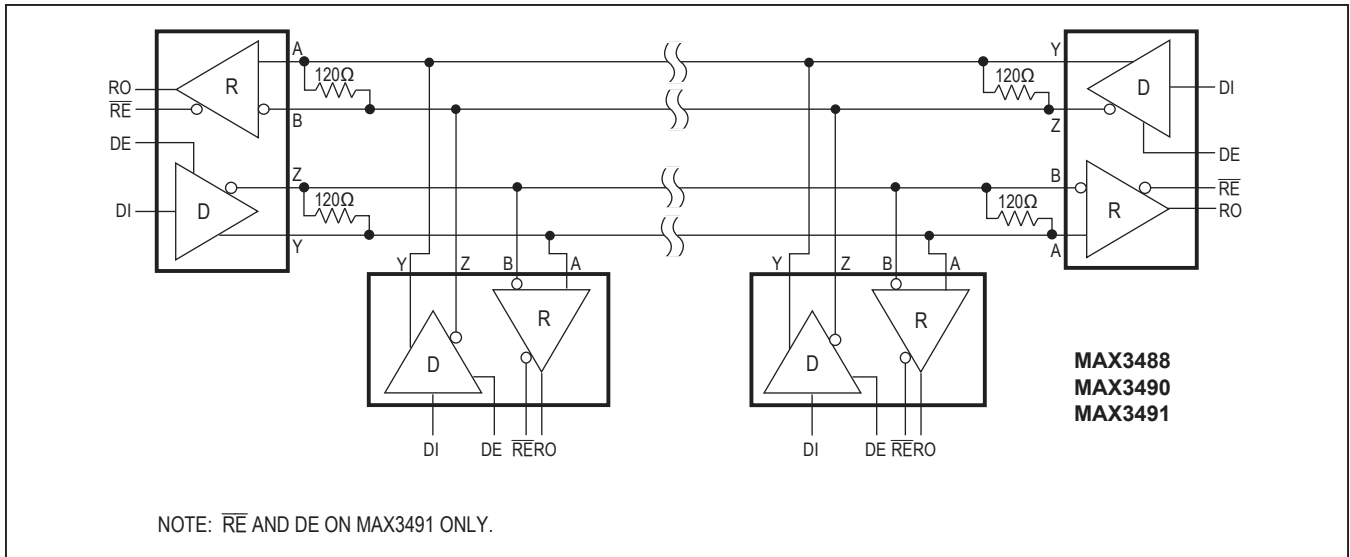

Figure 22. MAX3488/MAX3490/MAX3491 Full-Duplex RS-485 Network

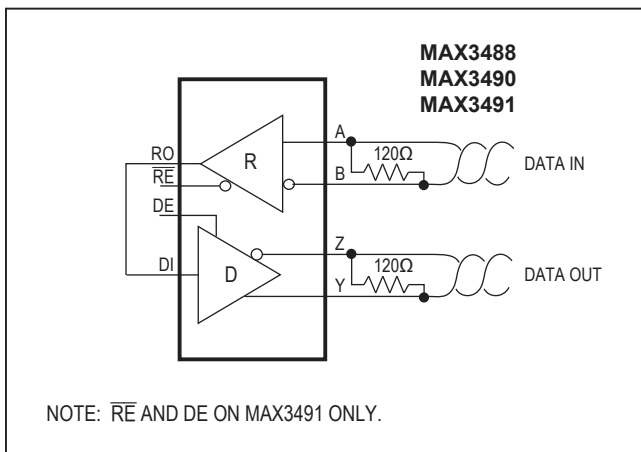

Figure 23. Line Repeater for MAX3488/MAX3490/MAX3491

MAX3483/MAX3485/
 MAX3486/MAX3488/
 MAX3490/MAX3491

3.3V-Powered, 10Mbps and Slew-Rate-Limited
 True RS-485/RS-422 Transceivers

Ordering Information (continued)

MAX3486 CPA	0°C to +70°C	8 Plastic DIP
MAX3486CSA	0°C to +70°C	8 SO
MAX3486C/D	0°C to +70°C	Dice*
MAX3486EPA	-40°C to +85°C	8 Plastic DIP
MAX3486ESA	-40°C to +85°C	8 SO
MAX3488 CPA	0°C to +70°C	8 Plastic DIP
MAX3488CSA	0°C to +70°C	8 SO
MAX3488C/D	0°C to +70°C	Dice*
MAX3488EPA	-40°C to +85°C	8 Plastic DIP
MAX3488ESA	-40°C to +85°C	8 SO
MAX3490 CPA	0°C to +70°C	8 Plastic DIP
MAX3490CSA	0°C to +70°C	8 SO
MAX3490C/D	0°C to +70°C	Dice*
MAX3490EPA	-40°C to +85°C	8 Plastic DIP
MAX3490ESA	-40°C to +85°C	8 SO
MAX3491 CPD	0°C to +70°C	14 Plastic DIP
MAX3491CSD	0°C to +70°C	14 SO
MAX3491C/D	0°C to +70°C	Dice*
MAX3491EPD	-40°C to +85°C	14 Plastic DIP
MAX3491ESD	-40°C to +85°C	14 SO

* Contact factory for for dice specifications.

Chip Topography

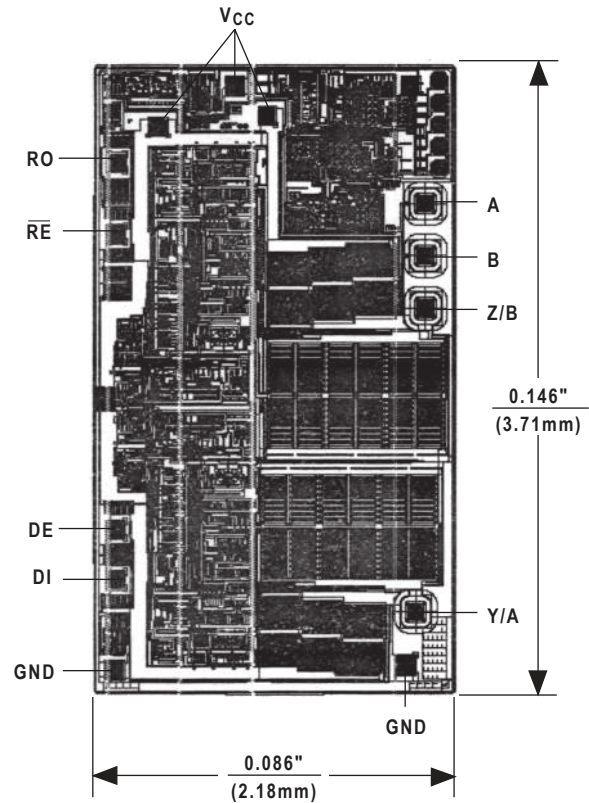

TRANSISTOR COUNT: 810
 SUBSTRATE CONNECTED TO GROUND

MAX3483/MAX3485/
MAX3486/MAX3488/
MAX3490/MAX3491

3.3V-Powered, 10Mbps and Slew-Rate-Limited
True RS-485/RS-422 Transceivers

Revision History

REVISION NUMBER	REVISION DATE	DESCRIPTION	PAGES CHANGED
0	12/94	Initial release	—
1	5/19	Updated Absolute Maximum Ratings and Selection table, added Package Information section	1, 2

For pricing, delivery, and ordering information, please visit Maxim Integrated's online storefront at <https://www.maximintegrated.com/en/storefront/storefront.html>.

Maxim Integrated cannot assume responsibility for use of any circuitry other than circuitry entirely embodied in a Maxim Integrated product. No circuit patent licenses are implied. Maxim Integrated reserves the right to change the circuitry and specifications without notice at any time. The parametric values (min and max limits) shown in the Electrical Characteristics table are guaranteed. Other parametric values quoted in this data sheet are provided for guidance.