

# TMC2226-BOB

Document Revision V1.00 • 2021-Feb-03

## Module Top View

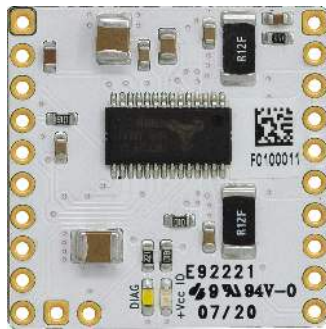

## Features and additional Resources

- TMC2226-SA stepper motor driver
- Supply voltage 5-28V
- $I_{phase}$  up to  $2.0A_{RMS}$
- Quiet operation with StealthChop2™
- Sensorless stall detection StallGuard4™
- Configuration and extended diagnostics via UART
- Control via Step&Dir interface
- Board width 1.0", board height 1.0"
- 2x10 pin 0.1" header rows for pins/connectors
- Link to [additional information and IC data sheet](#)

## Pin List

Left	Signal	Right	Signal
1	+VCC_IO	11	+VM
2	GND	12	GND
3	UART_RX	13	B1 (Motor Phase B)
4	UART_TX	14	B2 (Motor Phase B)
5	VREF	15	A1 (Motor Phase A)
6	GND	16	A2 (Motor Phase A)
7	CLK16	17	GND
8	ENN	18	MS1
9	STEP	19	MS2
10	DIR	20	SPREAD
21	INDEX	22	DIAG

## Bill of Materials

Pcs.	Value	Footprint	Description
1	R0603/1R1/1%	0603	Resistor
1	R0603/100k/1%	0603	Resistor
2	R0603/1k/1%	0603	Resistor
1	R0603/220R/1%	0603	Resistor
1	1uF, 50V	0603	Capacitor
2	10uF, 50V	1210	Capacitor
2	R2010/1W/0R12	2010	Resistor
1	2u2/50V	0603	Capacitor
1	22nF/50V	0805	Capacitor
4	100nF, 50V	0603	Capacitor
1	blue/0603	0603	LED
1	white/0603	0603	LED
1	TMC2226-SA	HTSSOP28, 9.7x6.4mm	<a href="#">Trinamic Stepper Motor Driver</a>

## Schematics

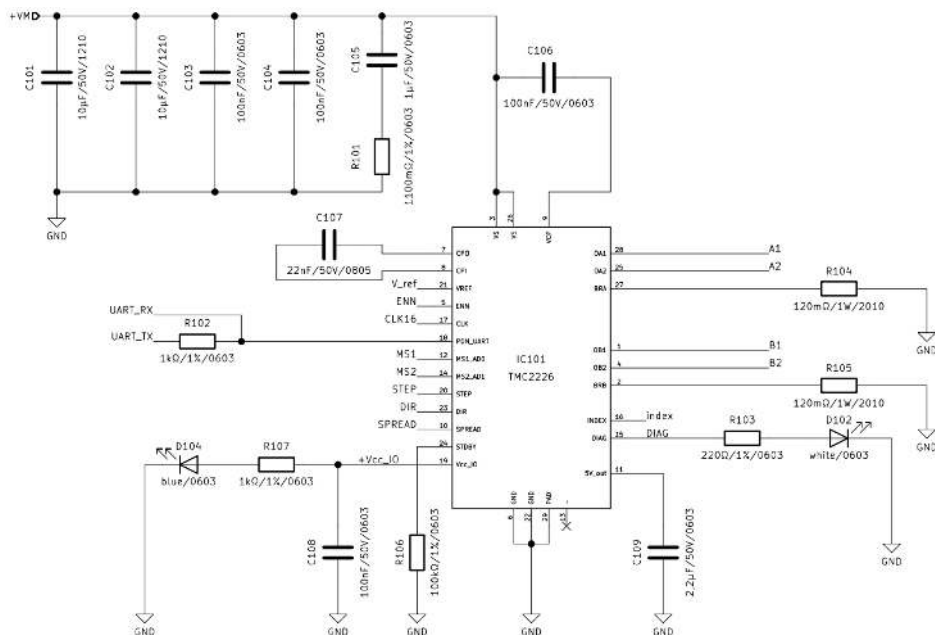

©2021 TRINAMIC Motion Control GmbH & Co. KG, Hamburg, Germany  
 Terms of delivery and rights to technical change reserved.  
 Download newest version at [www.trinamic.com](http://www.trinamic.com)

