



ST92F124xx ST92F150Cxx ST92F150JDV1 ST92F250CV2

8/16-bit single voltage Flash MCU family with RAM, E³™ (emulated EEPROM), CAN 2.0B and J1850 BLPD

Memories

- Internal Memory: Single Voltage Flash up to 256 Kbytes, RAM up to 8Kbytes, 1K byte E³™ (Emulated EEPROM)
- In-Application Programming (IAP)
- 224 general purpose registers (register file) available as RAM, accumulators or index pointers

Clock, Reset and Supply Management

- Register-oriented 8/16 bit CORE with RUN, WFI, SLOW, HALT and STOP modes
- 0-24 MHz Operation (Int. Clock), 4.5-5.5 V range
- PLL Clock Generator (3-5 MHz crystal)
- Minimum instruction time: 83 ns (24 MHz int. clock)

Up to 80 I/O pins

Interrupt Management

- 4 external fast interrupts + 1 NMI
- Up to 16 pins programmable as wake-up or additional external interrupt with multi-level interrupt handler

DMA controller for reduced processor overhead

Timers

- 16-bit Timer with 8-bit Prescaler, and Watchdog Timer (activated by software or by hardware)
- 16-bit Standard Timer that can be used to generate a time base independent of PLL Clock Generator
- Two 16-bit independent Extended Function Timers (EFTs) with Prescaler, up to two Input Captures and up to two Output Compares
- Two 16-bit Multifunction Timers, with Prescaler, up to two Input Captures and up to two Output Compares

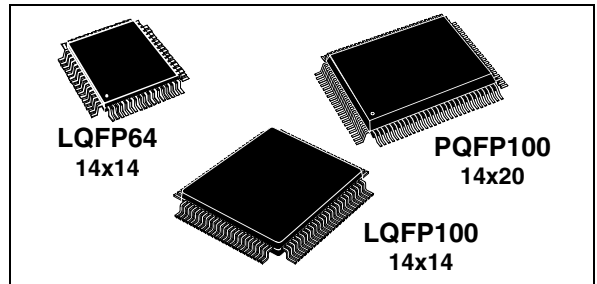

Communication Interfaces

- Serial Peripheral Interface (SPI) with selectable Master/Slave mode
- One Multiprotocol Serial Communications Interface with asynchronous and synchronous capabilities
- One asynchronous Serial Communications Interface with 13-bit LIN Synch Break generation capability
- J1850 Byte Level Protocol Decoder (JBLPD)
- Up to two full I²C multiple Master/Slave Interfaces supporting Access Bus
- Up to two CAN 2.0B Active interfaces

Analog peripheral (low current coupling)

- 10-bit A/D Converter with up to 16 robust input channels

Development Tools

- Free High performance development environment (IDE) based on Visual Debugger, Assembler, Linker, and C-Compiler; Real Time Operating System (OS-EK OS, CMX) and CAN drivers
- Hardware emulator and Flash programming board for development and ISP Flasher for production

Device Summary ²⁾

Features	ST92F124xx		ST92F150Cxx		ST92F150JDV1	ST92F250CV2
	ST92F124R1 ST92F124R9	ST92F124V1	ST92F150CR1 ST92F150CR9	ST92F150CV1 ST92F150CV9		
FLASH - bytes	64K/128K	128K	64K/128K	64K/128K	128K	256K
RAM - bytes	2K/4K	4K	2K/4K	2K/4K	6K	8K
E ³ ™ - bytes	1K	1K	1K	1K	1K	1K
Timers and Serial Interface	2 MFT, 2 EFT, STIM, WD, SCI, SPI, I ² C	2 MFT, 2 EFT, STIM, WD, 2 SCI, SPI, I ² C	2 MFT, 2 EFT, STIM, WD, SCI, SPI, I ² C	2 MFT, 2 EFT, STIM, WD, 2 SCI, SPI, I ² C	2 MFT, 2 EFT, STIM, WD, 2 SCI, SPI, I ² C	2 MFT, 2 EFT, STIM, WD, 2 SCI, SPI, 2 I ² C ¹⁾
ADC	16 x 10 bits	16 x 10 bits	16 x 10 bits	16 x 10 bits	16 x 10 bits	16 x 10 bits
Network Interface	-	LIN Master	CAN	CAN, LIN Master	2 CAN, J1850, LIN Master	CAN, LIN Master
Packages	LQFP64	P/LQFP100	LQFP64	P/LQFP100	P/LQFP100	

1) see Section 12.4 on page 406 for important information

2) see Table 71 on page 404 for the list of supported part numbers

Table of Contents

1 GENERAL DESCRIPTION	5
1.1 INTRODUCTION	5
1.2 PIN DESCRIPTION	11
1.3 VOLTAGE REGULATOR	23
1.4 I/O PORTS	24
1.5 ALTERNATE FUNCTIONS FOR I/O PORTS	26
1.6 OPERATING MODES	30
2 DEVICE ARCHITECTURE	31
2.1 CORE ARCHITECTURE	31
2.2 MEMORY SPACES	31
2.3 SYSTEM REGISTERS	34
2.4 MEMORY ORGANIZATION	42
2.5 MEMORY MANAGEMENT UNIT	43
2.6 ADDRESS SPACE EXTENSION	44
2.7 MMU REGISTERS	45
2.8 MMU USAGE	49
3 SINGLE VOLTAGE FLASH & E3™ (EMULATED EEPROM)	50
3.1 INTRODUCTION	50
3.2 FUNCTIONAL DESCRIPTION	52
3.3 REGISTER DESCRIPTION	56
3.4 WRITE OPERATION EXAMPLE	60
3.5 PROTECTION STRATEGY	61
3.6 FLASH IN-SYSTEM PROGRAMMING	66
4 REGISTER AND MEMORY MAP	68
4.1 INTRODUCTION	68
4.2 MEMORY CONFIGURATION	68
4.3 ST92F124/F150/F250 REGISTER MAP	74
5 INTERRUPTS	92
5.1 INTRODUCTION	92
5.2 INTERRUPT VECTORING	92
5.3 INTERRUPT PRIORITY LEVELS	94
5.4 PRIORITY LEVEL ARBITRATION	94
5.5 ARBITRATION MODES	95
5.6 EXTERNAL INTERRUPTS	100
5.7 STANDARD INTERRUPTS (CAN AND SCI-A)	102
5.8 TOP LEVEL INTERRUPT	104
5.9 DEDICATED ON-CHIP PERIPHERAL INTERRUPTS	104
5.10 INTERRUPT RESPONSE TIME	105
5.11 INTERRUPT REGISTERS	106
5.12 WAKE-UP / INTERRUPT LINES MANAGEMENT UNIT (WUIMU)	113
6 ON-CHIP DIRECT MEMORY ACCESS (DMA)	121
6.1 INTRODUCTION	121
6.2 DMA PRIORITY LEVELS	121
6.3 DMA TRANSACTIONS	122
6.4 DMA CYCLE TIME	124
6.5 SWAP MODE	124

Table of Contents

6.6	DMA REGISTERS	125
7	RESET AND CLOCK CONTROL UNIT (RCCU)	126
7.1	INTRODUCTION	126
7.2	CLOCK CONTROL UNIT	126
7.3	CLOCK MANAGEMENT	128
7.4	CLOCK CONTROL REGISTERS	134
7.5	CRYSTAL OSCILLATOR	138
7.6	RESET/STOP MANAGER	140
8	EXTERNAL MEMORY INTERFACE (EXTMI)	142
8.1	INTRODUCTION	142
8.2	EXTERNAL MEMORY SIGNALS	143
8.3	REGISTER DESCRIPTION	148
9	I/O PORTS	151
9.1	INTRODUCTION	151
9.2	SPECIFIC PORT CONFIGURATIONS	151
9.3	PORT CONTROL REGISTERS	151
9.4	INPUT/OUTPUT BIT CONFIGURATION	152
9.5	ALTERNATE FUNCTION ARCHITECTURE	156
9.6	I/O STATUS AFTER WFI, HALT AND RESET	156
10	ON-CHIP PERIPHERALS	157
10.1	TIMER/WATCHDOG (WDT)	157
10.2	STANDARD TIMER (STIM)	164
10.3	EXTENDED FUNCTION TIMER (EFT)	167
10.4	MULTIFUNCTION TIMER (MFT)	188
10.5	MULTIPROTOCOL SERIAL COMMUNICATIONS INTERFACE (SCI-M)	212
10.6	ASYNCHRONOUS SERIAL COMMUNICATIONS INTERFACE (SCI-A)	237
10.7	SERIAL PERIPHERAL INTERFACE (SPI)	250
10.8	I2C BUS INTERFACE	262
10.9	J1850 BYTE LEVEL PROTOCOL DECODER (JBLPD)	284
10.10	CONTROLLER AREA NETWORK (BXCAN)	325
10.11	10-BIT ANALOG TO DIGITAL CONVERTER (ADC)	362
11	ELECTRICAL CHARACTERISTICS	375
12	GENERAL INFORMATION	403
12.1	ORDERING INFORMATION	403
12.2	VERSION-SPECIFIC SALES CONDITIONS	403
12.3	PACKAGE MECHANICAL DATA	405
12.4	SOLDERING AND GLUEABILITY INFORMATION	406
12.5	DEVELOPMENT TOOLS	407
13	KNOWN LIMITATIONS	408
13.1	FLASH ERASE SUSPEND LIMITATIONS	408
13.2	FLASH CORRUPTION WHEN EXITING STOP MODE	409
13.3	I2C LIMITATIONS	411
13.4	SCI-A AND CAN INTERRUPTS	413
13.5	SCI-A MUTE MODE	413
13.6	CAN FIFO CORRUPTION WHEN 2 FIFO MESSAGES ARE PENDING	414
13.7	MFT DMA MASK BIT RESET WHEN MFT0 DMA PRIORITY LEVEL IS SET TO 0 ...	419

Table of Contents

13.8 EMULATION CHIP LIMITATIONS	423
14 REVISION HISTORY	428

1 GENERAL DESCRIPTION

1.1 INTRODUCTION

The ST92F124/F150/F250 microcontroller is developed and manufactured by STMicroelectronics using a proprietary n-well HCMOS process. Its performance derives from the use of a flexible 256-register programming model for ultra-fast context switching and real-time event response. The intelligent on-chip peripherals offload the ST9 core from I/O and data management processing tasks allowing critical application tasks to get the maximum use of core resources. The new-generation ST9 MCU devices now also support low power consumption and low voltage operation for power-efficient and low-cost embedded systems.

1.1.1 ST9+ Core

The advanced Core consists of the Central Processing Unit (CPU), the Register File, the Interrupt and DMA controller, and the Memory Management Unit. The MMU allows a single linear address space of up to 4 Mbytes.

Four independent buses are controlled by the Core: a 22-bit memory bus, an 8-bit register data bus, an 8-bit register address bus and a 6-bit interrupt/DMA bus which connects the interrupt and DMA controllers in the on-chip peripherals with the core.

This multiple bus architecture makes the ST9 family devices highly efficient for accessing on and off-chip memory and fast exchange of data with the on-chip peripherals.

The general-purpose registers can be used as accumulators, index registers, or address pointers. Adjacent register pairs make up 16-bit registers for addressing or 16-bit processing. Although the ST9 has an 8-bit ALU, the chip handles 16-bit operations, including arithmetic, loads/stores, and memory/register and memory/memory exchanges.

The powerful I/O capabilities demanded by microcontroller applications are fulfilled by the ST92F150/F124 with 48 (64-pin devices) or 77 (100-pin devices) I/O lines dedicated to digital Input/Output and with 80 I/O lines by the ST92F250. These lines are grouped into up to ten 8-bit I/O Ports and can be configured on a bit basis under software control to provide timing, status signals, an address/data bus for interfacing to the external memory, timer inputs and outputs, analog inputs, external interrupts and serial or parallel I/O. Two memory spaces are available to support this wide range of configurations: a combined Program/Data Memory Space and the internal Register File,

which includes the control and status registers of the on-chip peripherals.

1.1.2 External Memory Interface

100-pin devices have a 22-bit external address bus allowing them to address up to 4M bytes of external memory.

1.1.3 On-chip Peripherals

Two 16-bit Multifunction Timers, each with an 8 bit Prescaler and 12 operating modes allow simple use for complex waveform generation and measurement, PWM functions and many other system timing functions by the usage of the two associated DMA channels for each timer.

Two Extended Function Timers provide further timing and signal generation capabilities.

A Standard Timer can be used to generate a stable time base independent from the PLL.

An I²C interface (two in the ST92F250 device) provides fast I²C and Access Bus support.

The SPI is a synchronous serial interface for Master and Slave device communication. It supports single master and multimaster systems.

A J1850 Byte Level Protocol Decoder is available (ST92F150JDV1 device only) for communicating with a J1850 network.

The bxCAN (basic extended) interface (two in the ST92F150JDV1 device) supports 2.0B Active protocol. It has 3 transmit mailboxes, 2 independent receive FIFOs and 8 filters.

In addition, there is an 16 channel Analog to Digital Converter with integral sample and hold, fast conversion time and 10-bit resolution.

There is one Multiprotocol Serial Communications Interface with an integral generator, asynchronous and synchronous capability (fully programmable format) and associated address/wake-up option, plus two DMA channels.

On 100-pin devices, there is an additional asynchronous Serial Communications interface with 13-bit LIN Synch Break generation capability.

Finally, a programmable PLL Clock Generator allows the usage of standard 3 to 5 MHz crystals to obtain a large range of internal frequencies up to 24 MHz. Low power Run (SLOW), Wait For Interrupt, low power Wait For Interrupt, STOP and HALT modes are also available.

Figure 1. ST92F124R9: Architectural Block Diagram

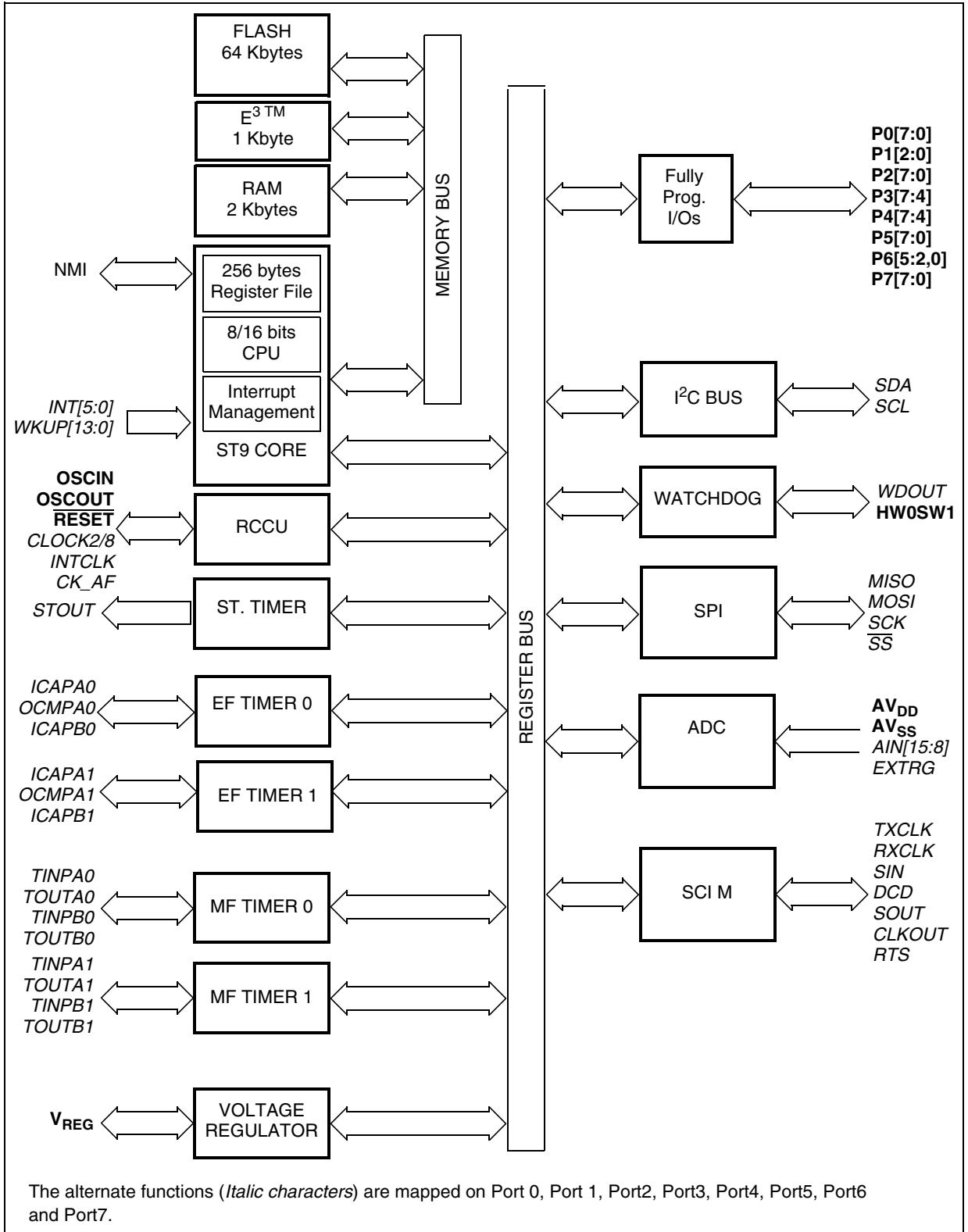

Figure 2. ST92F124V1: Architectural Block Diagram

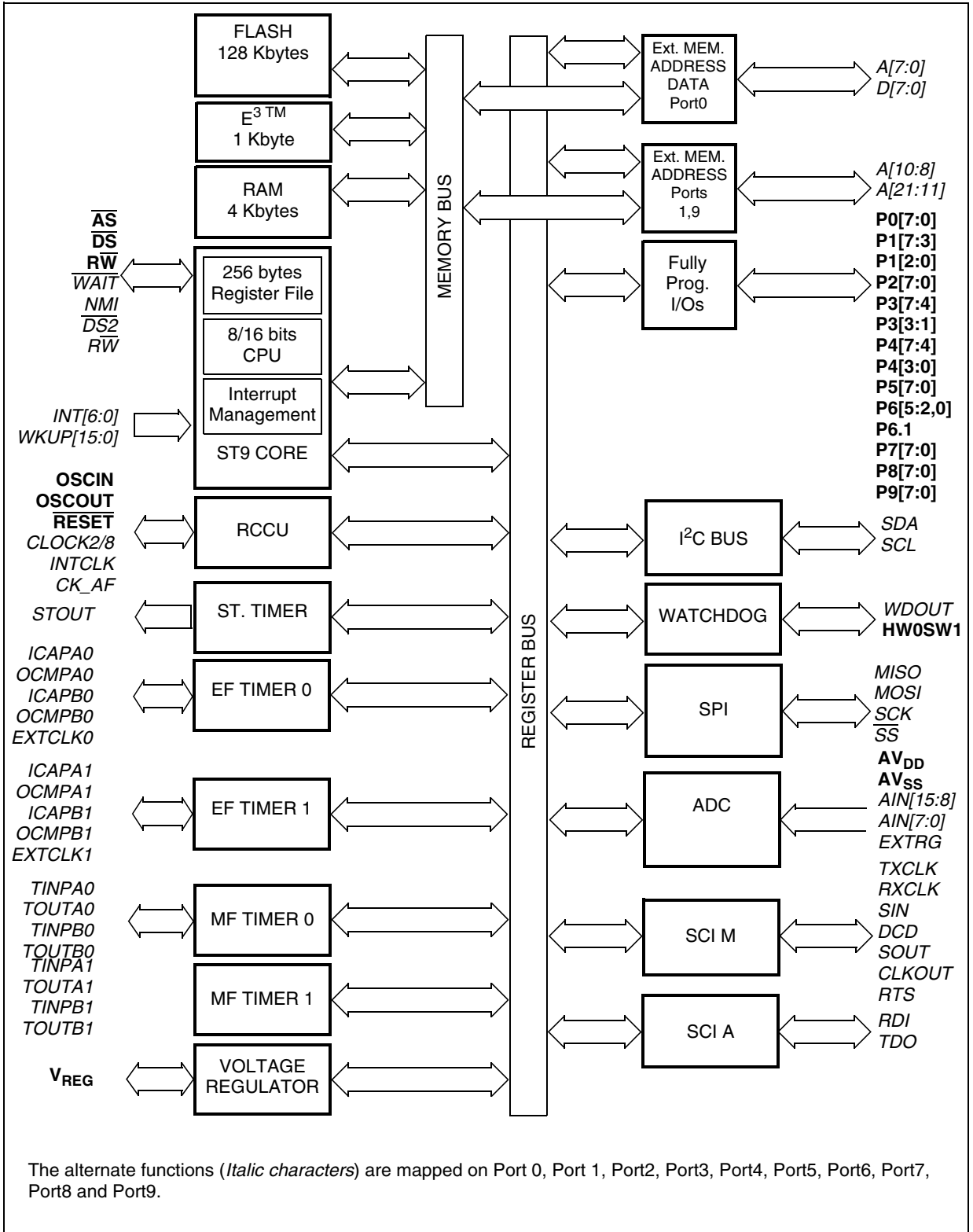

Figure 3. ST92F150C(R/V)1/9: Architectural Block Diagram

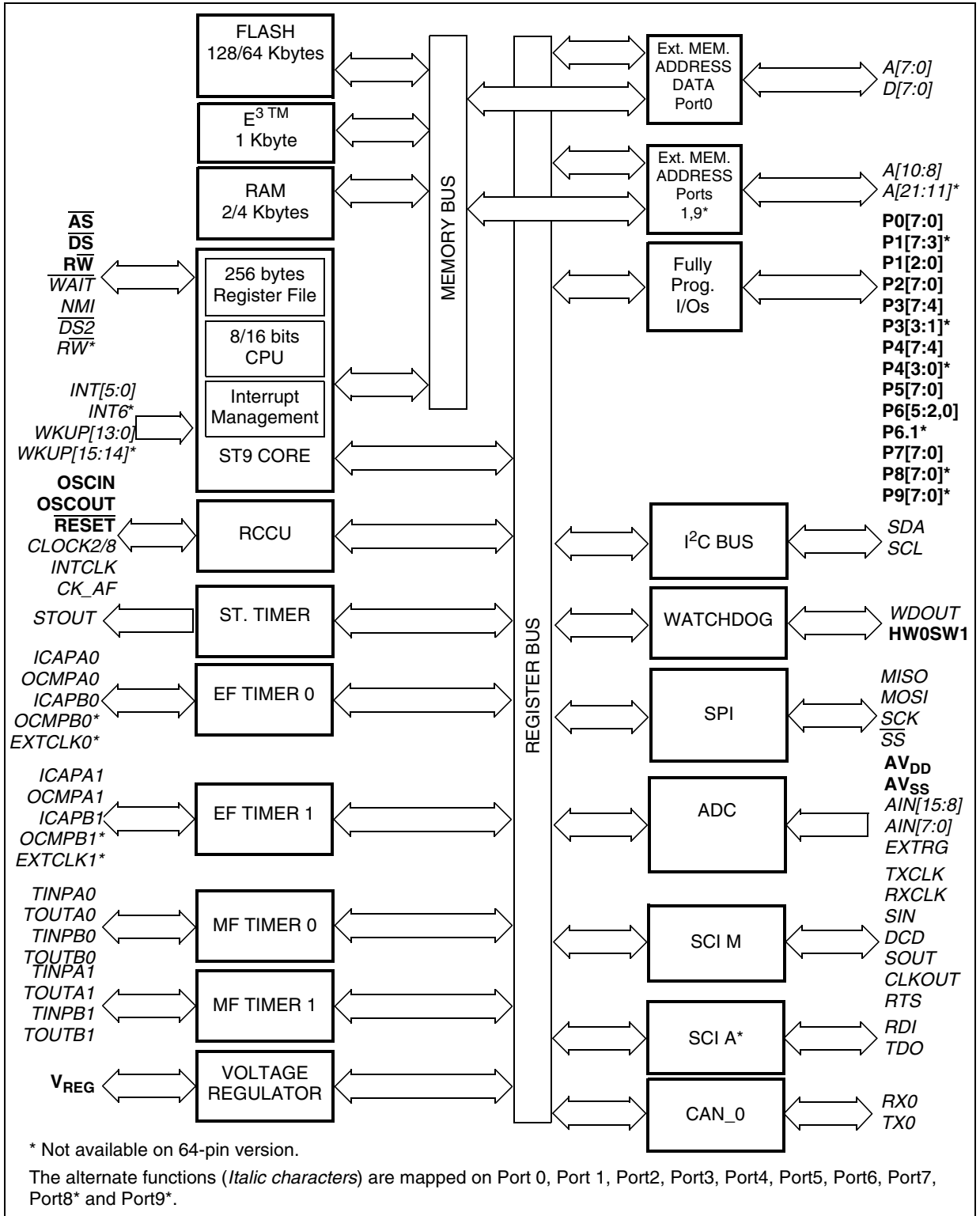

Figure 4. ST92F150JDV1: Architectural Block Diagram

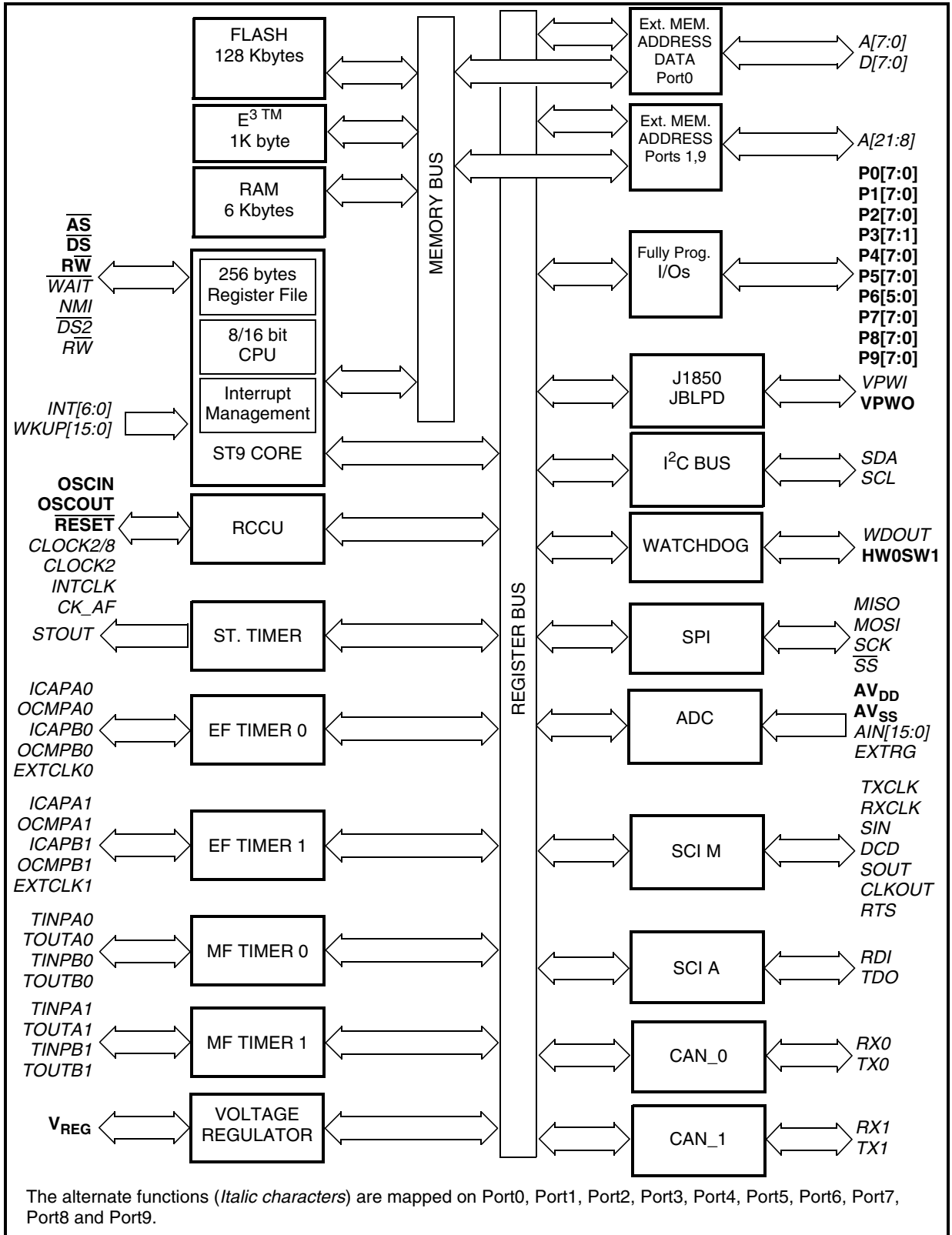
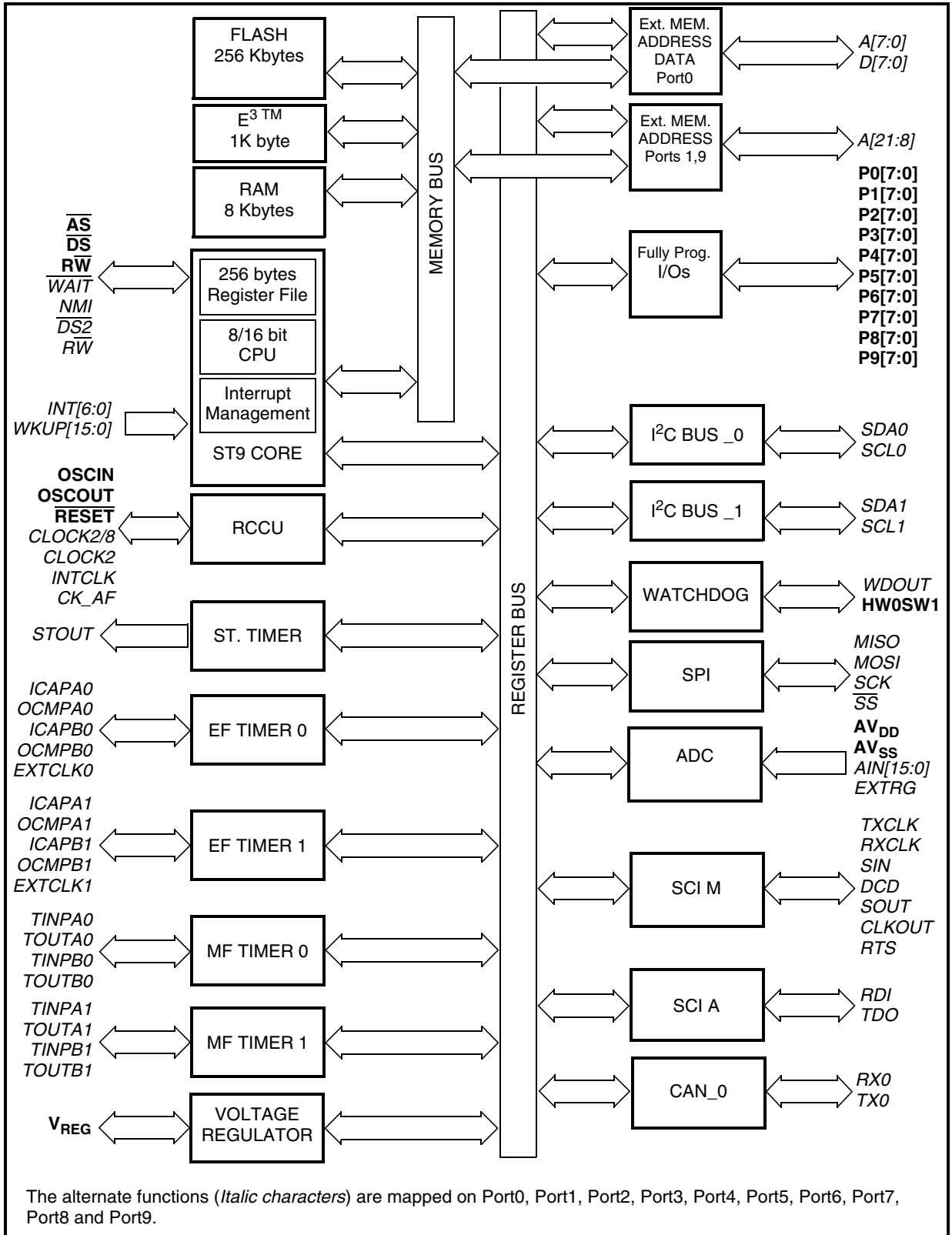

Figure 5. ST92F250CV2: Architectural Block Diagram



1.2 PIN DESCRIPTION

AS. Address Strobe (output, active low, 3-state). Address Strobe is pulsed low once at the beginning of each memory cycle. The rising edge of \overline{AS} indicates that address, Read/Write (RW), and Data signals are valid for memory transfers.

DS. Data Strobe (output, active low, 3-state). Data Strobe provides the timing for data movement to or from Port 0 for each memory transfer. During a write cycle, data out is valid at the leading edge of \overline{DS} . During a read cycle, Data In must be valid prior to the trailing edge of \overline{DS} . When the ST9 accesses on-chip memory, \overline{DS} is held high during the whole memory cycle.

RESET. Reset (input, active low). The ST9 is initialised by the Reset signal. With the deactivation of RESET, program execution begins from the Program memory location pointed to by the vector contained in program memory locations 00h and 01h.

RW. Read/Write (output, 3-state). Read/Write determines the direction of data transfer for external memory transactions. RW is low when writing to external memory, and high for all other transactions.

OSCIN, OSCOUT. Oscillator (input and output). These pins connect a parallel-resonant crystal, or an external source to the on-chip clock oscillator and buffer. OSCIN is the input of the oscillator inverter; OSCOUT is the output of the oscillator inverter.

HW0SW1. When connected to V_{DD} through a 1K pull-up resistor, the software watchdog option is selected. When connected to V_{SS} through a 1K pull-down resistor, the hardware watchdog option is selected.

VPWO. This pin is the output line of the J1850 peripheral (JBLPD). It is available only on some devices.

RX1/WKUP6. Receive Data input of CAN1 and Wake-up line 6. Available only on some devices. When the CAN1 peripheral is disabled, a pull-up resistor is connected internally to this pin.

TX1. Transmit Data output of CAN1. Available on some devices.

P0[7:0], P1[7:0] or P9[7:2] (Input/Output, TTL or CMOS compatible). 11 lines (64-pin devices) or 22 lines (100-pin devices) providing the external memory interface for addressing 2K or 4M bytes of external memory.

P0[7:0], P1[2:0], P2[7:0], P3[7:4], P4.[7:4], P5[7:0], P6[5:2,0], P7[7:0] I/O Port Lines (Input/Output, TTL or CMOS compatible). I/O lines grouped into I/O ports of 8 bits, bit programmable under software control as general purpose I/O or as alternate functions.

P1[7:3], P3[3:1], P4[3:0], P6.1, P8[7:0], P9[7:0] Additional I/O Port Lines available on 100-pin versions only.

P3.0, P6[7:6] Additional I/O Port Lines available on ST92F250 version only.

AVDD. Analog V_{DD} of the Analog to Digital Converter (common for ADC 0 and ADC 1). AVDD can be switched off when the ADC is not in use.

AVSS. Analog V_{SS} of the Analog to Digital Converter (common for ADC 0 and ADC 1).

VDD. Main Power Supply Voltage. Four pins are available on 100-pin versions, two on 64-pin versions. The pins are internally connected.

VSS. Digital Circuit Ground. Four pins are available on 100-pin versions, two on 64-pin versions. The pins are internally connected.

VTEST Power Supply Voltage for Flash test purposes. This pin must be kept to 0 in user mode.

VREG. Stabilization capacitors for the internal voltage regulator. The user must connect external stabilization capacitors to these pins. Refer to [Figure 16](#).

1.2.1 I/O Port Alternate Functions

Each pin of the I/O ports of the ST92F124/F150/F250 may assume software programmable Alternate Functions as shown in [Section 1.4](#).

1.2.2 Termination of Unused Pins

For unused pins, input mode is not recommended. These pins must be kept at a fixed voltage using the output push pull mode of the I/O or an external pull-up or pull-down resistor.

Figure 6. ST92F124R9/R1: Pin Configuration (Top-view LQFP64)

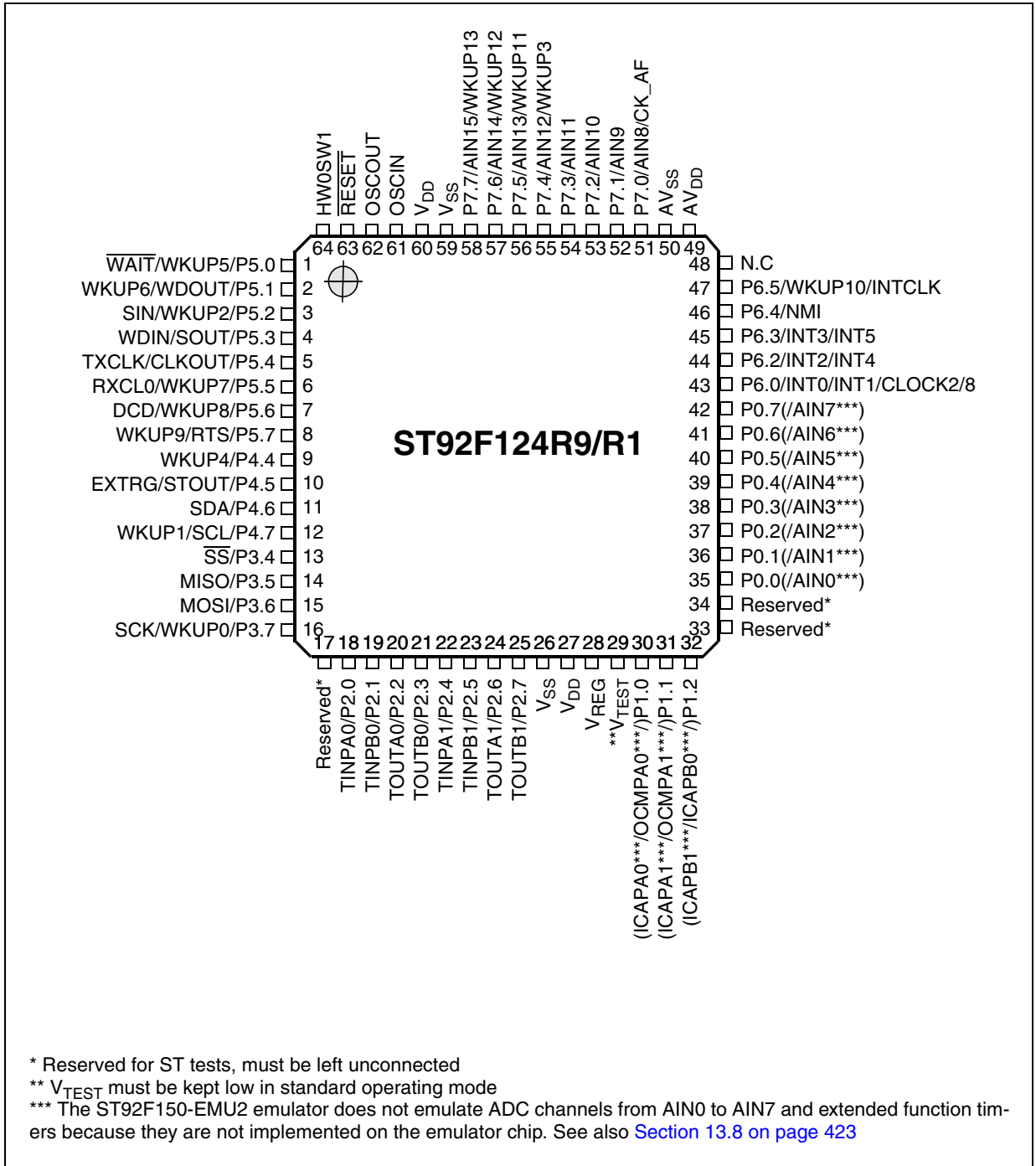

Figure 7. ST92F124V1: Pin Configuration (Top-view PQFP100)

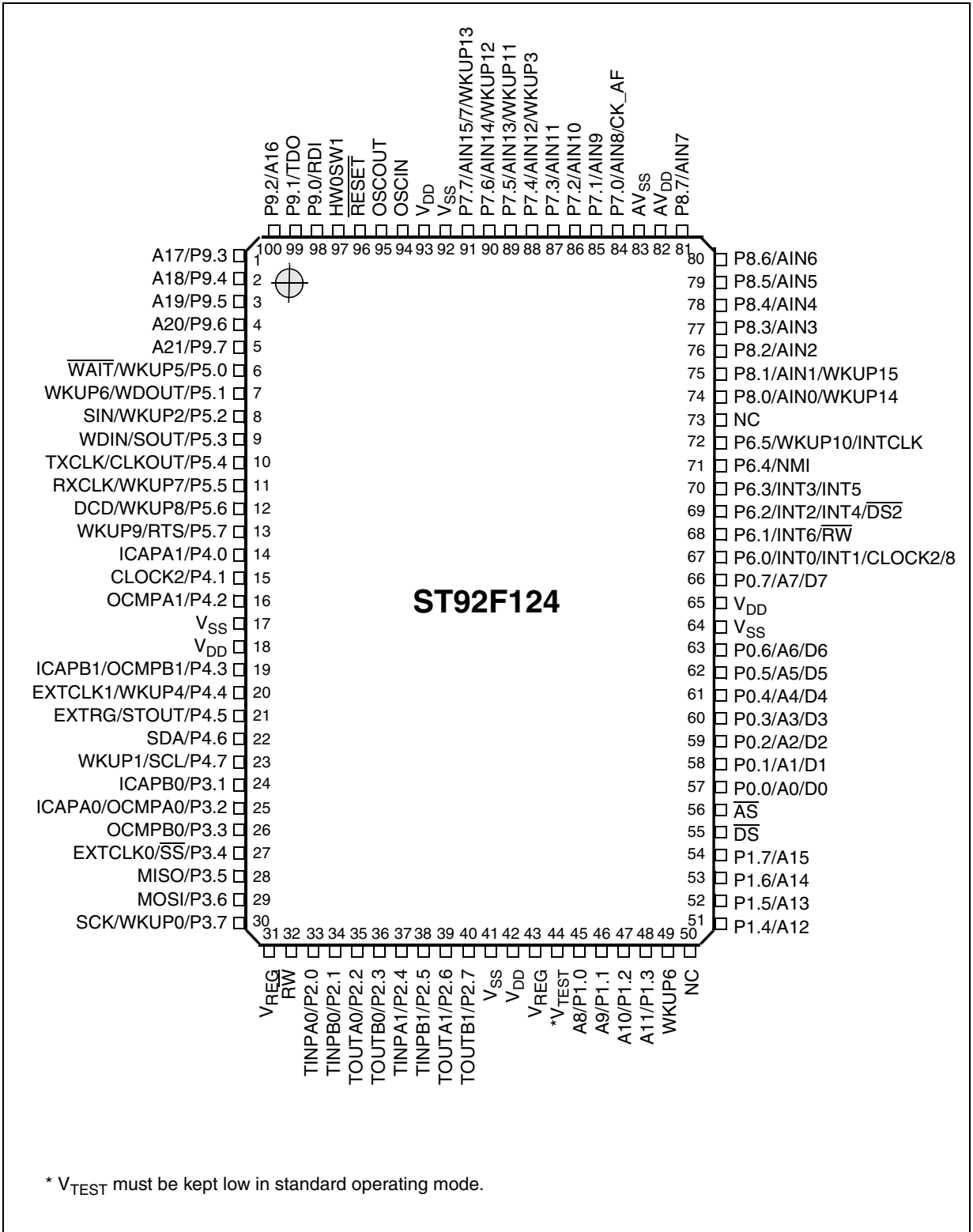

Figure 8. ST92F124V1: Pin Configuration (Top-view LQFP100)

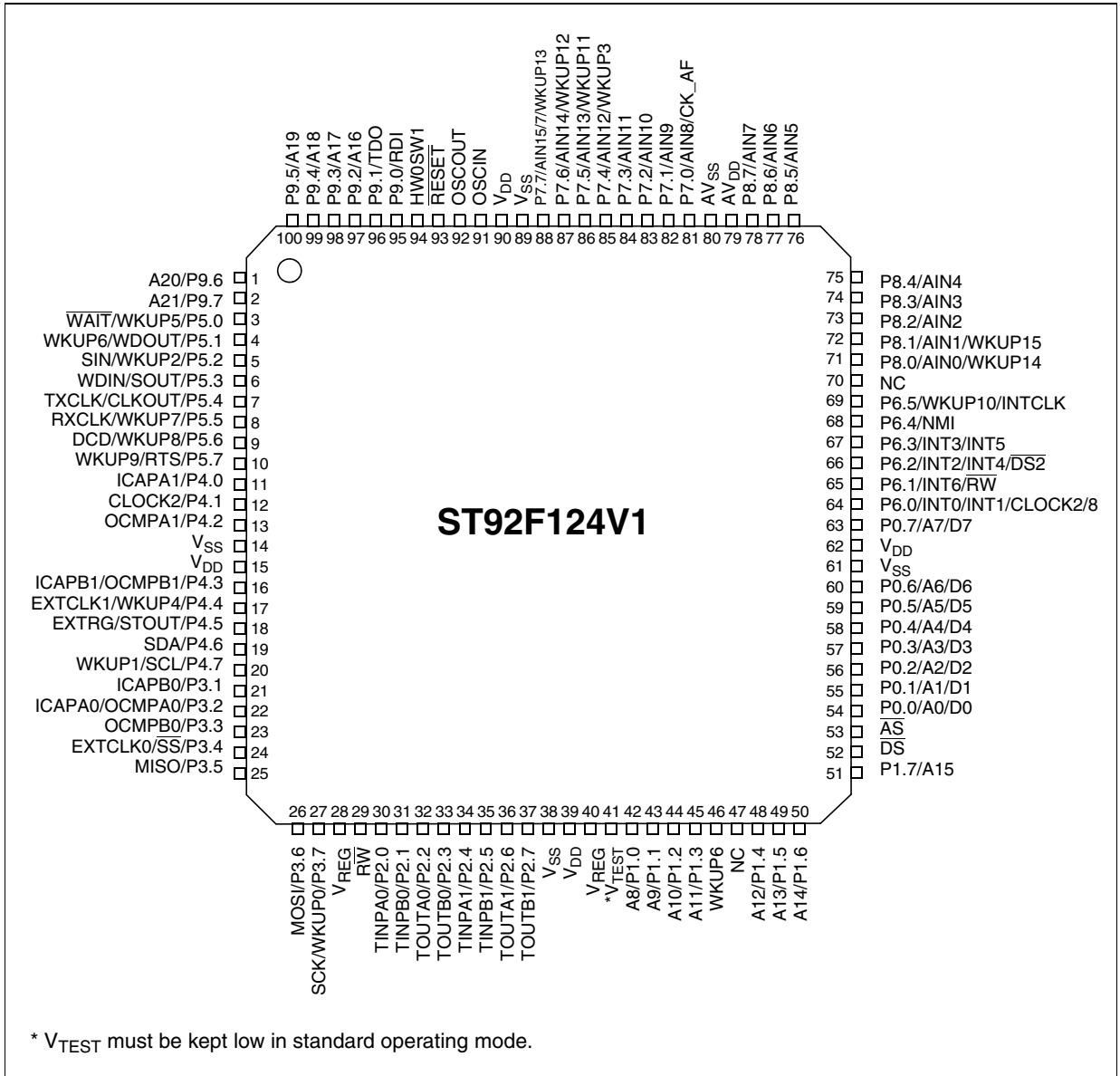

Figure 9. ST92F150: Pin Configuration (Top-view LQFP64)

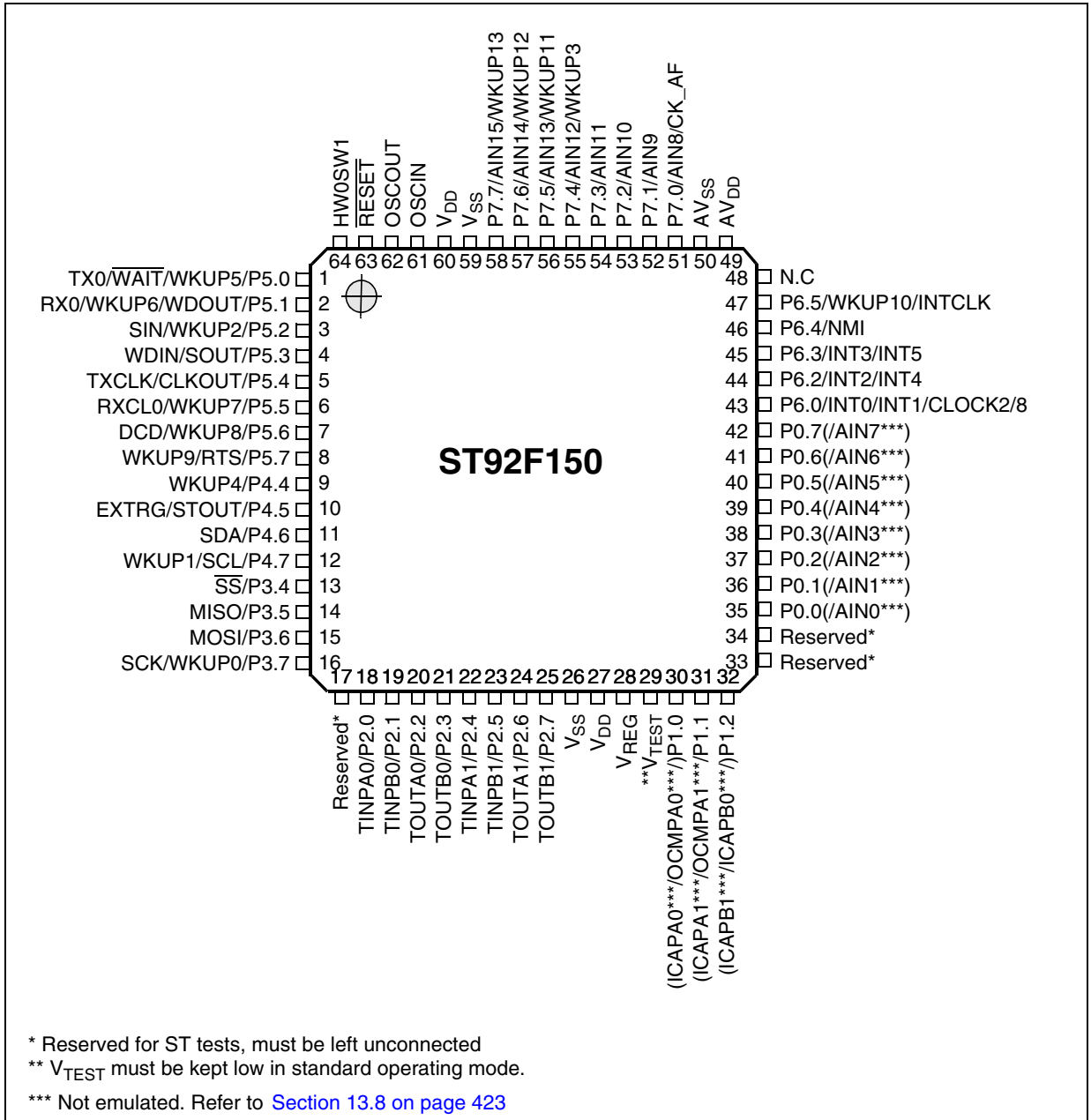
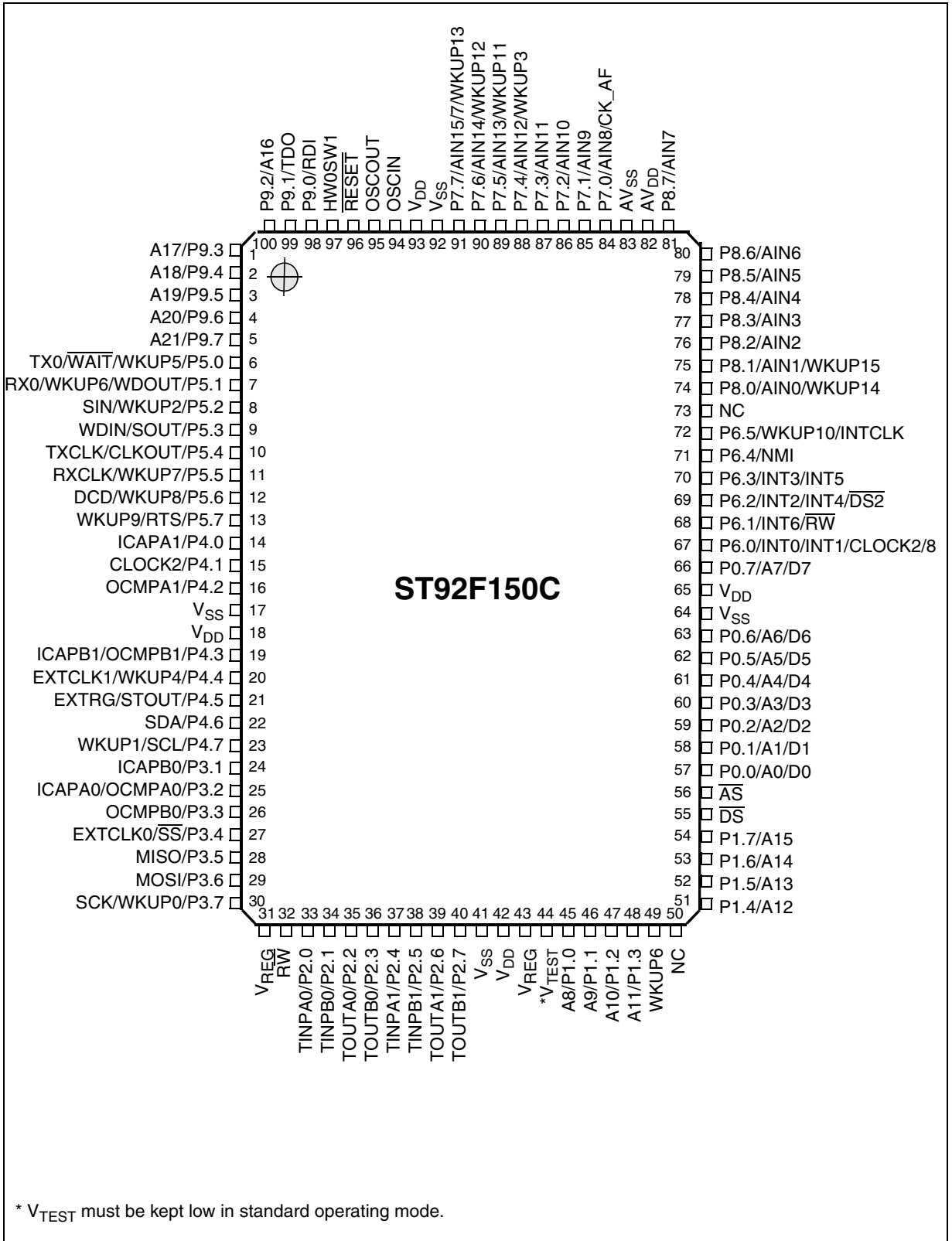
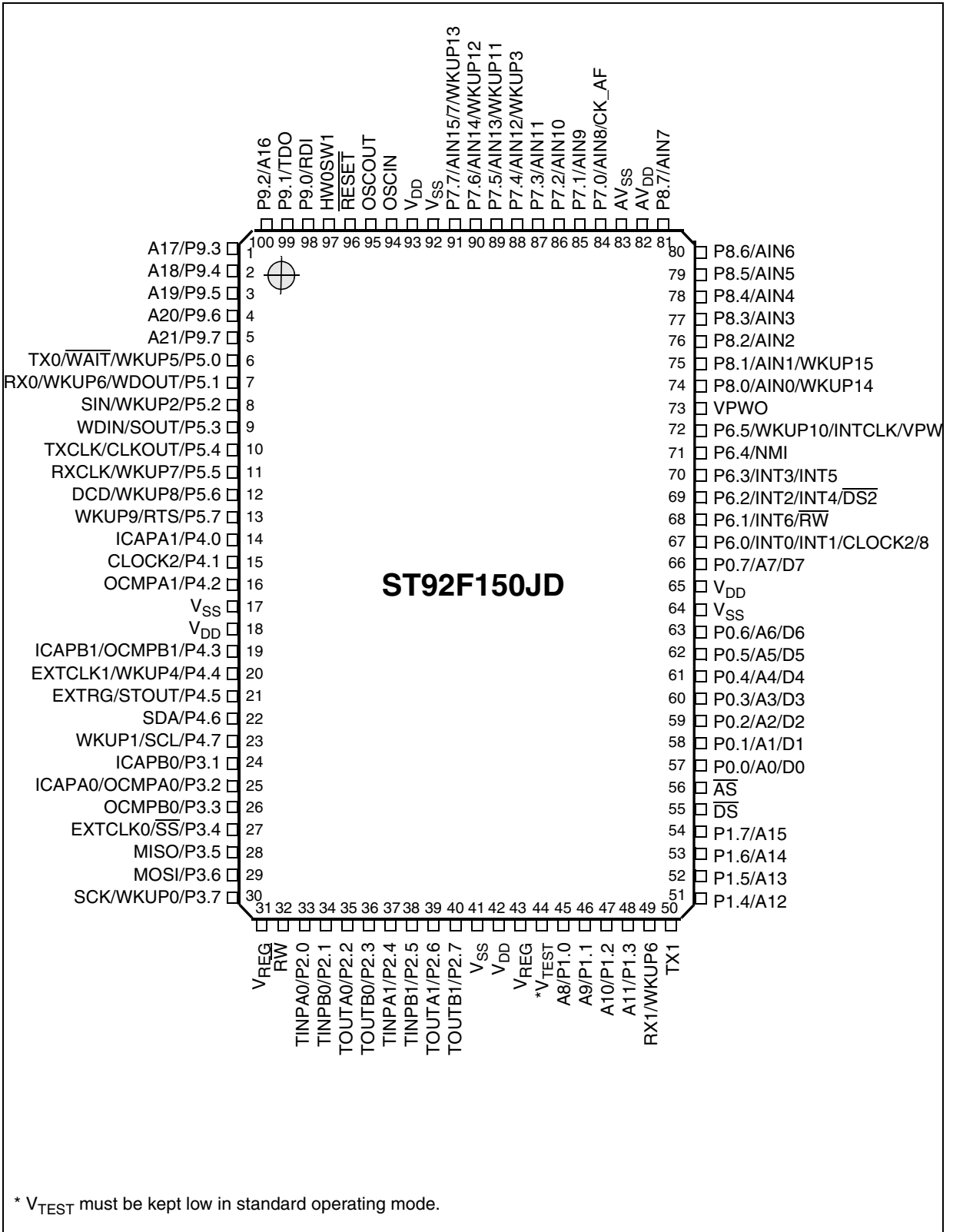

Figure 10. ST92F150C: Pin Configuration (Top-view PQFP100)



* V_{TEST} must be kept low in standard operating mode.

Figure 11. ST92F150JD: Pin Configuration (Top-view PQFP100)



* V_{TEST} must be kept low in standard operating mode.

Figure 12. ST92F150C: Pin Configuration (Top-view LQFP100)

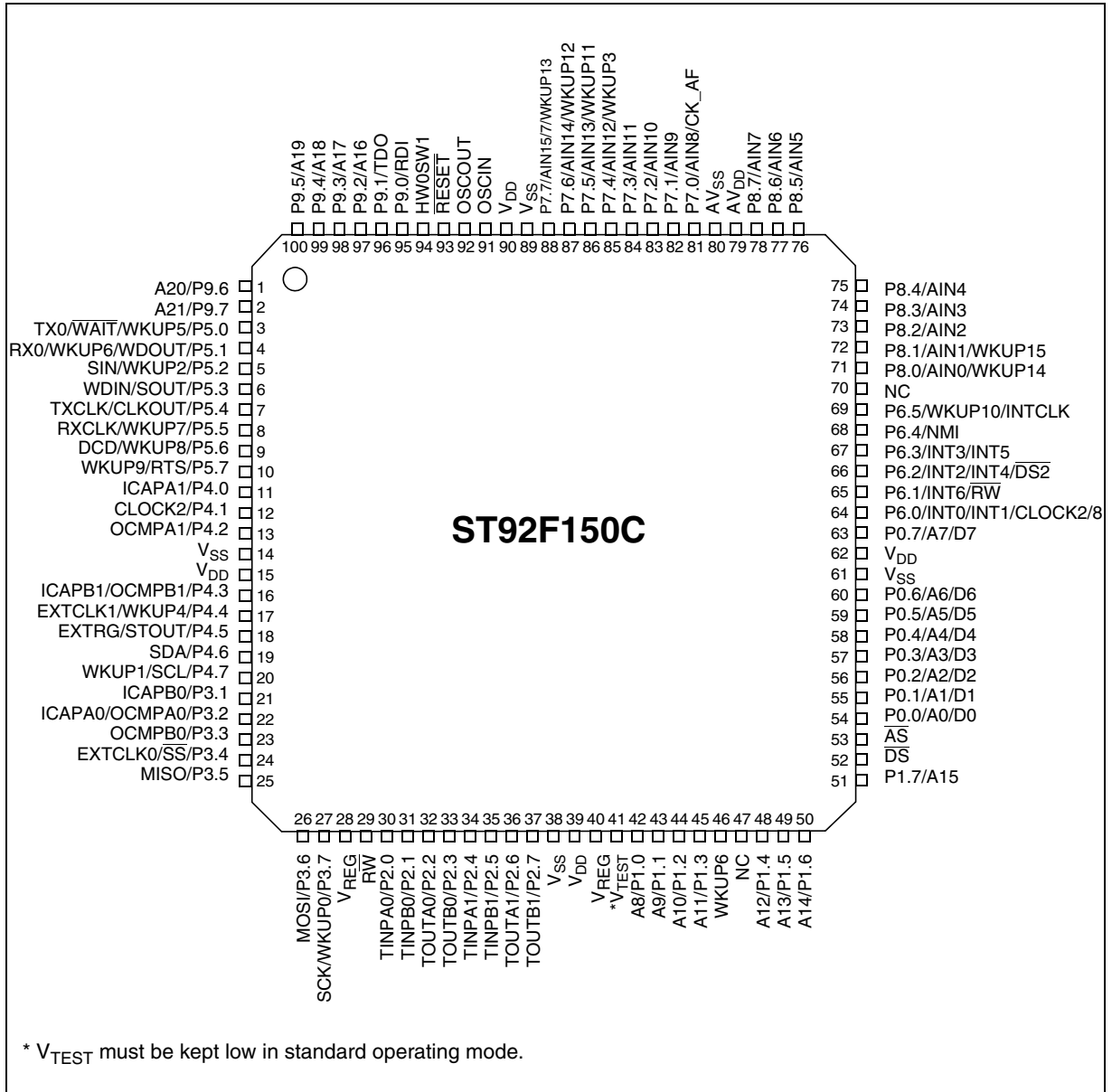

Figure 13. ST92F150JD: Pin Configuration (Top-view LQFP100)

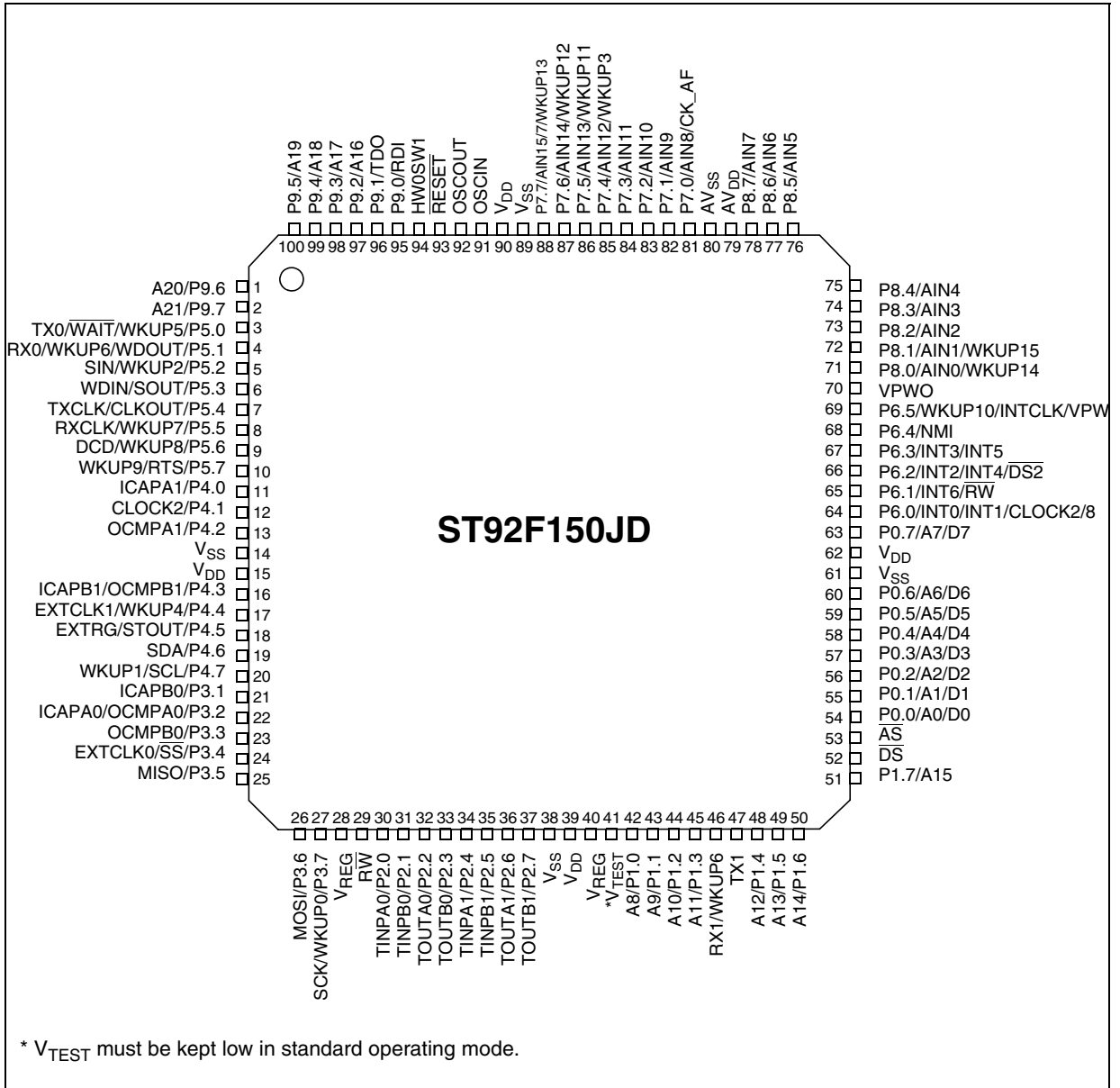

Figure 15. ST92F250: Pin Configuration (Top-view LQFP100)

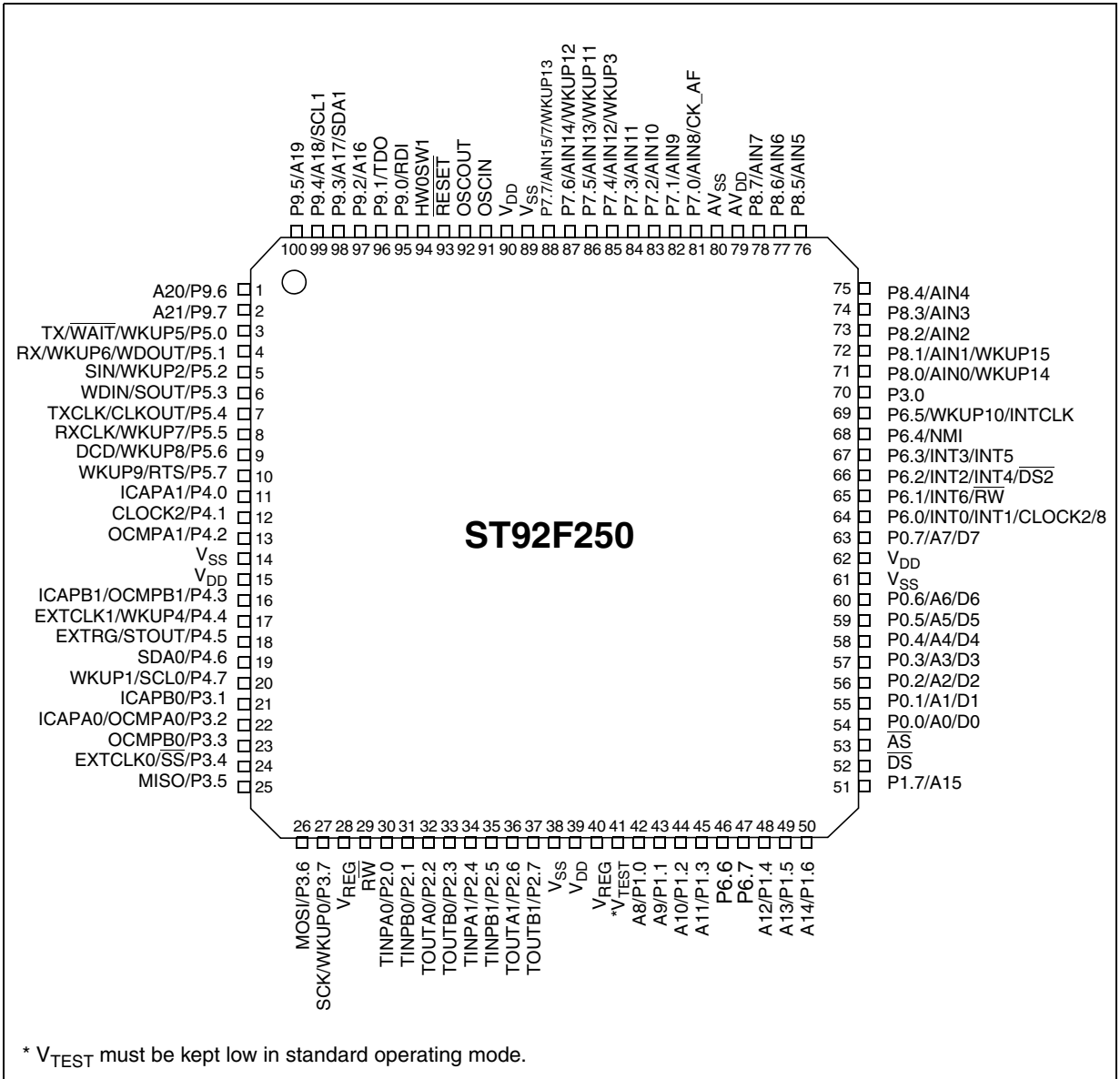

Table 1. ST92F124/F150/F250 Power Supply Pins

Name	Function	LQFP64	PQFP100	LQFP100
V _{DD}	Main Power Supply Voltage (Pins internally connected)	-	18	15
		27	42	39
		-	65	62
		60	93	90
V _{SS}	Digital Circuit Ground (Pins internally connected)	-	17	14
		26	41	38
		-	64	61
		59	92	89
AV _{DD}	Analog Circuit Supply Voltage	49	82	79
AV _{SS}	Analog Circuit Ground	50	83	80
V _{TEST}	Must be kept low in standard operating mode	29	44	41
V _{REG}	Stabilization capacitor(s) for internal voltage regulator	28	31 43	28 40

Table 2. ST92F124/F150/F250 Primary Function Pins

Name	Function	LQFP64	PQFP100	LQFP100
\overline{AS}	Address Strobe	-	56	53
\overline{DS}	Data Strobe	-	55	52
\overline{RW}	Read/Write	-	32	29
OSCIN	Crystal Oscillator Input	61	94	91
OSCOU _T	Crystal Oscillator Output	62	95	92
\overline{RESET}	Reset to initialize the Microcontroller	63	96	93
HW0SW1	Watchdog HW/SW enabling selection	64	97	94
VPWO ¹⁾	J1850 JBLPD Output	-	73	70
RX1/WKUP6 ¹⁾	CAN1 Receive Data / Wake-up Line 6	-	49	46
TX1 ¹⁾	CAN1 Transmit Data.	-	50	47

Note 1: ST92F150JDV1 only.

1.3 VOLTAGE REGULATOR

The internal Voltage Regulator (VR) is used to power the microcontroller starting from the external power supply. The VR comprises a Main voltage regulator and a Low-power regulator.

- The Main voltage regulator generates sufficient current for the microcontroller to operate in any mode. It has a static power consumption (300 μ A typ.).
- The separate Low-Power regulator consumes less power is used only when the microcontroller is in Low Power mode. It has a different design from the main VR and generates a lower,

non-stabilized and non-thermally-compensated voltage sufficient for maintaining the data in RAM and the Register File.

For both the Main VR and the Low-Power VR, stabilization is achieved by an external capacitor, connected to one of the V_{REG} pins. The minimum recommended value is 300 nF, and care must be taken to minimize distance between the chip and the capacitor. Care should also be taken to limit the serial inductance to less than 60nH.

Figure 16. Recommended Connections for V_{REG}

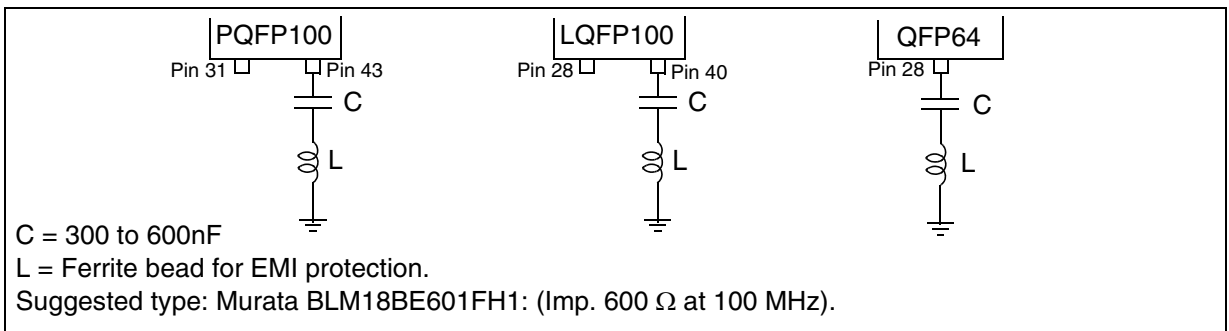

IMPORTANT: The V_{REG} pin cannot be used to drive external devices.

Figure 17. Minimum Required Connections for V_{REG}

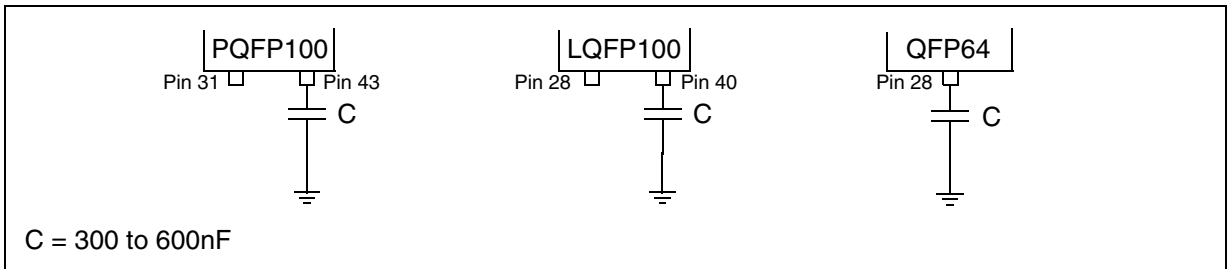

Note: Pin 31 of PQFP100 or pin 28 of LQFP100 can be left unconnected. A secondary stabilization network can also be connected to these pins.

1.4 I/O PORTS

Port 0, Port 1 and Port 9[7:2] provide the external memory interface. All the ports of the device can be programmed as Input/Output or in Input mode, compatible with TTL or CMOS levels (except where Schmitt Trigger is present). Each bit can be programmed individually (Refer to the I/O ports chapter).

Internal Weak Pull-up

As shown in Table 3, not all input sections implement a Weak Pull-up. This means that the pull-up must be connected externally when the pin is not used or programmed as bidirectional.

TTL/CMOS Input

For all those port bits where no input schmitt trigger is implemented, it is always possible to program the input level as TTL or CMOS compatible by programming the relevant PxC2.n control bit. Refer I/O Ports Chapter to the section titled "Input/Output Bit Configuration".

Schmitt Trigger Input

Two different kinds of Schmitt Trigger circuitries are implemented: Standard and High Hysteresis. Standard Schmitt Trigger is widely used (see Table 3), while the High Hysteresis Schmitt Trigger is present on ports P4[7:6] and P6[5:4].

All inputs which can be used for detecting interrupt events have been configured with a "Standard" Schmitt Trigger, apart from the NMI pin which implements the "High Hysteresis" version. In this way, all interrupt lines are guaranteed as "edge sensitive".

Push-Pull/OD Output

The output buffer can be programmed as push-pull or open-drain: attention must be paid to the fact that the open-drain option corresponds only to a disabling of P-channel MOS transistor of the buffer itself: it is still present and physically connected to the pin. Consequently it is not possible to increase the output voltage on the pin over $V_{DD}+0.3$ Volt, to avoid direct junction biasing.

Pure Open-Drain Output

The user can increase the voltage on an I/O pin over $V_{DD}+0.3$ Volt where the P-channel MOS transistor is physically absent: this is allowed on all "Pure Open Drain" pins. In this case, the push-pull option is not available and any weak pull-up must be implemented externally.

Table 3. I/O Port Characteristics

	Input	Output	Weak Pull-Up	Reset State
Port 0[7:0]	TTL/CMOS	Push-Pull/OD	No	Bidirectional
Port 1[7:3]	TTL/CMOS	Push-Pull/OD	Yes	Bidirectional WPU
Port 1[2:0]	TTL/CMOS	Push-Pull/OD	No	Bidirectional
Port 2[1:0]	Schmitt trigger	Push-Pull/OD	Yes	Input
Port 2[3:2]	TTL/CMOS	Pure OD	No	Input CMOS
Port 2[5:4]	Schmitt trigger	Push-Pull/OD	Yes	Input
Port 2[7:6]	TTL/CMOS	Push-Pull/OD	Yes	Input CMOS
Port 3[2:0] ¹⁾	Schmitt trigger	Push-Pull/OD	Yes	Input
Port 3.3	TTL/CMOS	Push-Pull/OD	Yes	Input CMOS
Port 3[7:4]	Schmitt trigger	Push-Pull/OD	Yes	Input
Port 4.0, Port 4.4	Schmitt trigger	Push-Pull/OD	No	Input
Port 4.1	Schmitt trigger	Push-Pull/OD	Yes	Bidirectional WPU
Port 4.2, Port 4.5	TTL/CMOS	Push-Pull/OD	Yes	Input CMOS
Port 4.3	Schmitt trigger	Push-Pull/OD	Yes	Input
Port 4[7:6]	High hysteresis Schmitt trigger	Pure OD	No	Input
Port 5[2:0], Port 5[7:4]	Schmitt trigger	Push-Pull/OD	No	Input
Port 5.3	TTL/CMOS	Push-Pull/OD	Yes	Input CMOS
Port 6[3:0]	Schmitt trigger	Push-Pull/OD	Yes	Input
Port 6[5:4]	High hysteresis Schmitt trigger	Push-Pull/OD	Yes	Input
Port 6[7:6] ¹⁾	Schmitt trigger	Push-Pull/OD	Yes	Input
Port 7[7:0]	Schmitt trigger	Push-Pull/OD	Yes	Input
Port 8[1:0]	Schmitt trigger	Push-Pull/OD	Yes	Input
Port 8[7:2]	Schmitt trigger	Push-Pull/OD	Yes	Bidirectional WPU
Port 9[7:0]	Schmitt trigger	Push-Pull/OD	Yes	Bidirectional WPU

Legend: WPU = Weak Pull-Up, OD = Open Drain.

Note 1: Port 3.0 and Port6 [7:6] present on ST92F250 version only.

How to Configure the I/O Ports

To configure the I/O ports, use the information in [Table 3](#), [Table 4](#) and the Port Bit Configuration Table in the I/O Ports Chapter (See [page 153](#)).

Input Note = the hardware characteristics fixed for each port line in [Table 3](#).

- If Input note = TTL/CMOS, either TTL or CMOS input level can be selected by software.
- If Input note = Schmitt trigger, selecting CMOS or TTL input by software has no effect, the input will always be Schmitt Trigger.

Alternate Functions (AF) = More than one AF cannot be assigned to an I/O pin at the same time:

An alternate function can be selected as follows.

AF Inputs:

- AF is selected implicitly by enabling the corresponding peripheral. Exception to this are ADC inputs which must be explicitly selected as AF input by software.

AF Outputs or Bidirectional Lines:

- In the case of Outputs or I/Os, AF is selected explicitly by software.

Example 1: SCI-M input

AF: SIN, Port: P5.2. Schmitt Trigger input.

Write the port configuration bits:

```
P5C2.2=1
P5C1.2=0
P5C0.2 =1
```

Enable the SCI peripheral by software as described in the SCI chapter.

Example 2: SCI-M output

AF: SOUT, Port: P5.3, Push-Pull/OD output.

Write the port configuration bits (for AF OUT PP):

```
P5C2.3=0
P5C1.3=1
P5C0.3 =1
```

Example 3: External Memory I/O

AF: A0/D0, Port : P0.0, Input Note: TTL/CMOS input.

Write the port configuration bits:

```
P0C2.0=1
P0C1.0=1
P0C0.0 =1
```

Example 4: Analog input

AF: AIN8, Port : 7.0, Analog input.

Write the port configuration bits:

```
P7C2.0=1
P7C1.0=1
P7C0.0 =1
```

1.5 Alternate Functions for I/O Ports

All the ports in the following table are useable for general purpose I/O (input, output or bidirectional).

Table 4. I/O Port Alternate Functions

Port Name	Pin No.			Alternate Functions		
	LQFP64	PQFP100	LQFP100			
P0.0	-	57	54	A0/D0	I/O	Address/Data bit 0
	35	-	-	AIN0 ¹⁾	I	Analog Data Input 0
P0.1	-	58	55	A1/D1	I/O	Address/Data bit 1
	36	-	-	AIN1 ¹⁾	I	Analog Data Input 1
P0.2	-	59	56	A2/D2	I/O	Address/Data bit 2
	37	-	-	AIN2 ¹⁾	I	Analog Data Input 2
P0.3	-	60	57	A3/D3	I/O	Address/Data bit 3
	38	-	-	AIN3 ¹⁾	I	Analog Data Input 3
P0.4	-	61	58	A4/D4	I/O	Address/Data bit 4
	39	-	-	AIN4 ¹⁾	I	Analog Data Input 4
P0.5	-	62	59	A5/D5	I/O	Address/Data bit 5
	40	-	-	AIN5 ¹⁾	I	Analog Data Input 5
P0.6	-	63	60	A6/D6	I/O	Address/Data bit 6
	41	-	-	AIN6 ¹⁾	I	Analog Data Input 6
P0.7	-	66	63	A7/D7	I/O	Address/Data bit 7
	42	-	-	AIN7 ¹⁾	I	Analog Data Input 7
P1.0	-	45	42	A8	I/O	Address bit 8
	30	-	-	ICAPA0 ¹⁾	I	Ext. Timer 0 - Input Capture A
				OCMPA0 ¹⁾	O	Ext. Timer 0 - Output Compare A
P1.1	-	46	43	A9	I/O	Address bit 9
	31	-	-	ICAPA1 ¹⁾	I	Ext. Timer 1- Input Capture A
				OCMPA1 ¹⁾	O	Ext. Timer 1- Output Compare A
P1.2	-	47	44	A10	I/O	Address bit 10
	32	-	-	ICAPB1 ¹⁾	I	Ext. Timer 1- Input Capture B
				ICAPB0 ¹⁾	I	Ext. Timer 0- Input Capture B
P1.3	-	48	45	A11	I/O	Address bit 11
P1.4	-	51	48	A12	I/O	Address bit 12
P1.5	-	52	49	A13	I/O	Address bit 13
P1.6	-	53	50	A14	I/O	Address bit 14
P1.7	-	54	51	A15	I/O	Address bit 15
P2.0	18	33	30	TINPA0	I	Multifunction Timer 0 - Input A
P2.1	19	34	31	TINPB0	I	Multifunction Timer 0 - Input B
P2.2	20	35	32	TOUTA0	O	Multifunction Timer 0 - Output A
P2.3	21	36	33	TOUTB0	O	Multifunction Timer 0 - Output B
P2.4	22	37	34	TINPA1	I	Multifunction Timer 1 - Input A

Port Name	Pin No.			Alternate Functions		
	LQFP64	PQFP100	LQFP100			
P2.5	23	38	35	TINPB1	I	Multifunction Timer 1 - Input B
P2.6	24	39	36	TOUTA1	O	Multifunction Timer 1 - Output A
P2.7	25	40	37	TOUTB1	O	Multifunction Timer 1 - Output B
P3.0 ²⁾	-	73	70			
P3.1	-	24	21	ICAPB0	I	Ext. Timer 0 - Input Capture B
P3.2	-	25	22	ICAPA0	I	Ext. Timer 0 - Input Capture A
				OCMPA0	O	Ext. Timer 0 - Output Compare A
P3.3	-	26	23	OCMPB0	O	Ext. Timer 0 - Output Compare B
P3.4	-	27	24	EXTCLK0	I	Ext. Timer 0 - Input Clock
				SS	I	SPI - Slave Select
P3.5	14	28	25	MISO	I/O	SPI - Master Input/Slave Output Data
P3.6	15	29	26	MOSI	I/O	SPI - Master Output/Slave Input Data
P3.7	16	30	27	SCK	I	SPI - Serial Input Clock
				WKUP0	I	Wake-up Line 0
				SCK	O	SPI - Serial Output Clock
P4.0	-	14	11	ICAPA1	I	Ext. Timer 1 - Input Capture A
P4.1	-	15	12	CLOCK2	O	CLOCK2 internal signal
P4.2	-	16	13	OCMPA1	O	Ext. Timer 1 - Output Compare A
P4.3	-	19	16	ICAPB1	I	Ext. Timer 1 - Input Capture B
				OCMPB1	O	Ext. Timer 1 - Output Compare B
P4.4	-	20	17	EXTCLK1	I	Ext. Timer 1 - Input Clock
				WKUP4	I	Wake-up Line 4
P4.5	10	21	18	EXTRG	I	ADC Ext. Trigger
				STOUT	O	Standard Timer Output
P4.6	11	22	19	SDA0	I/O	I ² C 0 Data
P4.7	12	23	20	WKUP1	I	Wake-up Line 1
				SCL0	I/O	I ² C 0 Clock
P5.0	1	6	3	$\overline{\text{WAIT}}$	I	External Wait Request
				WKUP5	I	Wake-up Line 5
				TX0 ²⁾	O	CAN 0 output
P5.1	2	7	4	WKUP6	I	Wake-up Line 6
				RX0 ²⁾	I	CAN 0 input
				WDOUT	O	Watchdog Timer Output
P5.2	3	8	5	SIN0	I	SCI-M - Serial Data Input
				WKUP2	I	Wake-up Line 2
P5.3	4	9	6	WDIN	I	Watchdog Timer Input
				SOUT	O	SCI-M - Serial Data Output

ST92F124/F150/F250 - GENERAL DESCRIPTION

Port Name	Pin No.			Alternate Functions		
	LQFP64	PQFP100	LQFP100			
P5.4	5	10	7	TXCLK	I	SCI-M - Transmit Clock Input
				CLKOUT	O	SCI-M - Clock Output
P5.5	6	11	8	RXCLK	I	SCI-M - Receive Clock Input
				WKUP7	I	Wake-up Line 7
P5.6	7	12	9	DCD	I	SCI-M - Data Carrier Detect
				WKUP8	I	Wake-up Line 8
P5.7	8	13	10	WKUP9	I	Wake-up Line 9
				RTS	O	SCI-M - Request To Send
P6.0	43	67	64	INT0	I	External Interrupt 0
				INT1	I	External Interrupt 1
				CLOCK2/8	O	CLOCK2 divided by 8
P6.1	-	68	65	INT6	I	External Interrupt 6
				R \bar{W}	O	Read/Write
P6.2	44	69	66	INT2	I	External Interrupt 2
				INT4	I	External Interrupt 4
				DS2	O	Data Strobe 2
P6.3	45	70	67	INT3	I	External Interrupt 3
				INT5	I	External Interrupt 5
P6.4	46	71	68	NMI	I	Non Maskable Interrupt
P6.5	47	72	69	WKUP10	I	Wake-up Line 10
				VPWI ²⁾	I	JBLPD input
				INTCLK	O	Internal Main Clock
P6.6 ²⁾	-	49	46			
P6.7 ²⁾	-	50	47			
P7.0	51	84	81	AIN8	I	Analog Data Input 8
				CK_AF	I	Clock Alternative Source
P7.1	52	85	82	AIN9	I	Analog Data Input 9
P7.2	53	86	83	AIN10	I	Analog Data Input 10
P7.3	54	87	84	AIN11	I	Analog Data Input 11
P7.4	55	88	85	WKUP3	I	Wake-up Line 3
				AIN12	I	Analog Data Input 12
P7.5	56	89	86	AIN13	I	Analog Data Input 13
				WKUP11	I	Wake-up Line 11
P7.6	57	90	87	AIN14	I	Analog Data Input 14
				WKUP12	I	Wake-up Line 12
P7.7	58	91	88	AIN15	I	Analog Data Input 15
				WKUP13	I	Wake-up Line 13

Port Name	Pin No.			Alternate Functions		
	LQFP64	PQFP100	LQFP100			
P8.0	-	74	71	AIN0	I	Analog Data Input 0
				WKUP14	I	Wake-up Line 14
P8.1	-	75	72	AIN1	I	Analog Data Input 1
				WKUP15	I	Wake-up Line 15
P8.2	-	76	73	AIN2	I	Analog Data Input 2
P8.3	-	77	74	AIN3	I	Analog Data Input 3
P8.4	-	78	75	AIN4	I	Analog Data Input 4
P8.5	-	79	76	AIN5	I	Analog Data Input 5
P8.6	-	80	77	AIN6	I	Analog Data Input 6
P8.7	-	81	78	AIN7	I	Analog Data Input 7
P9.0	-	98	95	RDI ²⁾	I	SCI-A Receive Data Input
P9.1	-	99	96	TDO ²⁾	O	SCI-A Transmit Data Output
P9.2	-	100	97	A16	O	Address bit 16
P9.3	-	1	98	A17 ³⁾	O	Address bit 17
				SDA1 ²⁾	I/O	I ² C 1 Data
P9.4	-	2	99	A18 ³⁾	O	Address bit 18
				SCL1 ²⁾	I/O	I ² C 1 Clock
P9.5	-	3	100	A19	O	Address bit 19
P9.6	-	4	1	A20	O	Address bit 20
P9.7	-	5	2	A21	O	Address bit 21

Note 1: The ST92F150-EMU2 emulator does not emulate ADC channels from AIN0 to AIN7 and extended function timers because they are not implemented on the emulator chip. See also [Section 13.8 on page 423](#).

Note 2: Available on some devices only.

Note 3: For the ST92F250 device, since A[18:17] share the same pins as SDA1 and SCL1 of I²C_1, these address bits are not available when the I²C_1 is in use (when I2CCR.PE bit is set).

1.6 OPERATING MODES

To optimize the performance versus the power consumption of the device, the ST92F124/F150/F250 supports different operating modes that can be dynamically selected depending on the performance and functionality requirements of the application at a given moment.

RUN MODE: This is the full speed execution mode with CPU and peripherals running at the maximum clock speed delivered by the Phase Locked Loop (PLL) of the Clock Control Unit (CCU).

SLOW MODE: Power consumption can be significantly reduced by running the CPU and the peripherals at reduced clock speed using the CPU Prescaler and CCU Clock Divider.

WAIT FOR INTERRUPT MODE: The Wait For Interrupt (WFI) instruction suspends program execution until an interrupt request is acknowledged. During WFI, the CPU clock is halted while the peripheral and interrupt controller keep running at a frequency depending on the CCU programming.

LOW POWER WAIT FOR INTERRUPT MODE: Combining SLOW mode and Wait For Interrupt mode it is possible to reduce the power consumption by more than 80%.

STOP MODE: When the STOP is requested by executing the STOP bit writing sequence (see dedicated section on Wake-up Management Unit paragraph), and if NMI is kept low, the CPU and the peripherals stop operating. Operations resume after a wake-up line is activated (16 wake-up lines plus NMI pin). See the RCCU and Wake-up Man-

agement Unit paragraphs in the following for the details. The difference with the HALT mode consists in the way the CPU exits this state: when the STOP is executed, the status of the registers is recorded, and when the system exits from the STOP mode the CPU continues the execution with the same status, without a system reset.

When the MCU enters STOP mode the Watchdog stops counting. After the MCU exits from STOP mode, the Watchdog resumes counting from where it left off.

When the MCU exits from STOP mode, the oscillator, which was sleeping too, requires about 5 ms to restart working properly (at a 4 MHz oscillator frequency). An internal counter is present to guarantee that all operations after exiting STOP Mode, take place with the clock stabilised.

The counter is active only when the oscillation has already taken place. This means that 1-2 ms must be added to take into account the first phase of the oscillator restart.

In STOP mode, the oscillator is stopped. Therefore, if the PLL is used to provide the CPU clock before entering STOP mode, it will have to be selected again when the MCU exits STOP mode.

HALT MODE: When executing the HALT instruction, and if the Watchdog is not enabled, the CPU and its peripherals stop operating and the status of the machine remains frozen (the clock is also stopped). A reset is necessary to exit from Halt mode.

2 DEVICE ARCHITECTURE

2.1 CORE ARCHITECTURE

The ST9 Core or Central Processing Unit (CPU) features a highly optimised instruction set, capable of handling bit, byte (8-bit) and word (16-bit) data, as well as BCD and Boolean formats; 14 addressing modes are available.

Four independent buses are controlled by the Core: a 16-bit Memory bus, an 8-bit Register data bus, an 8-bit Register address bus and a 6-bit Interrupt/DMA bus which connects the interrupt and DMA controllers in the on-chip peripherals with the Core.

This multiple bus architecture affords a high degree of pipelining and parallel operation, thus making the ST9 family devices highly efficient, both for numerical calculation, data handling and with regard to communication with on-chip peripheral resources.

2.2 MEMORY SPACES

There are two separate memory spaces:

- The Register File, which comprises 240 8-bit registers, arranged as 15 groups (Group 0 to E), each containing sixteen 8-bit registers plus up to 64 pages of 16 registers mapped in Group F,

which hold data and control bits for the on-chip peripherals and I/Os.

- A single linear memory space accommodating both program and data. All of the physically separate memory areas, including the internal ROM, internal RAM and external memory are mapped in this common address space. The total addressable memory space of 4 Mbytes (limited by the size of on-chip memory and the number of external address pins) is arranged as 64 segments of 64 Kbytes. Each segment is further subdivided into four pages of 16 Kbytes, as illustrated in [Figure 18](#). A Memory Management Unit uses a set of pointer registers to address a 22-bit memory field using 16-bit address-based instructions.

2.2.1 Register File

The Register File consists of (see [Figure 19](#)):

- 224 general purpose registers (Group 0 to D, registers R0 to R223)
- 6 system registers in the System Group (Group E, registers R224 to R239)
- Up to 64 pages, depending on device configuration, each containing up to 16 registers, mapped to Group F (R240 to R255), see [Figure 20](#).

Figure 18. Single Program and Data Memory Address Space

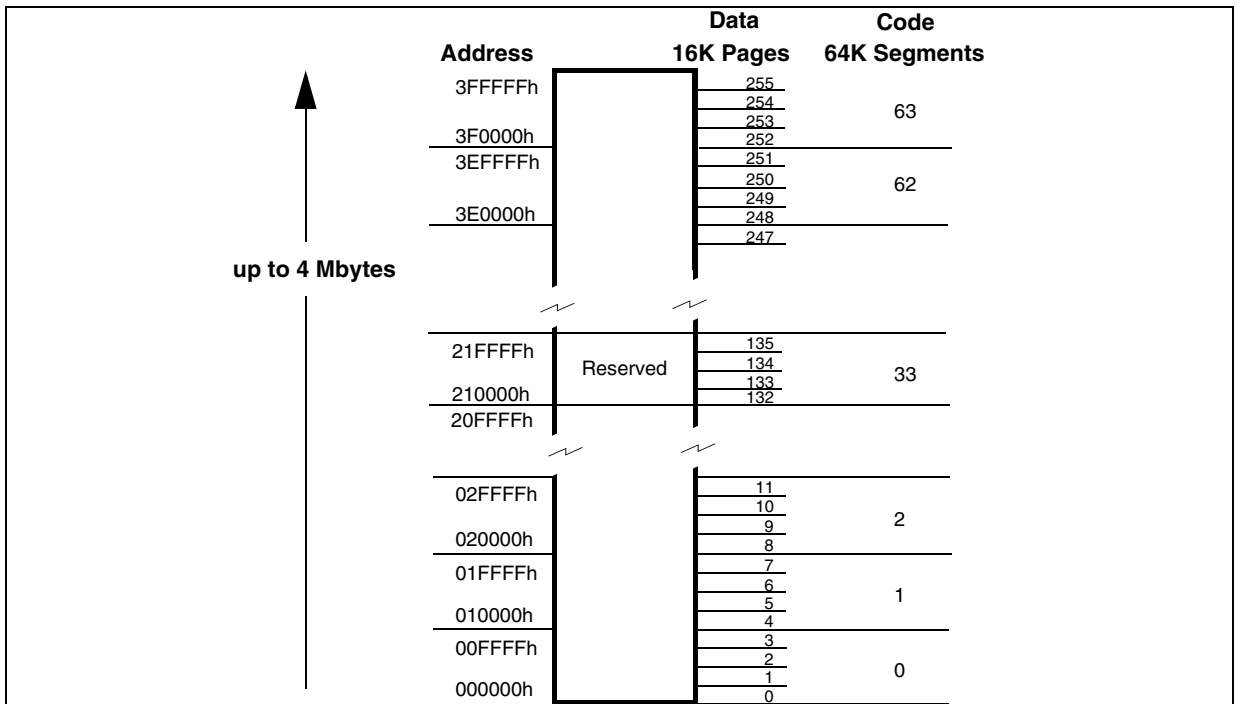

MEMORY SPACES (Cont'd)

Figure 19. Register Groups

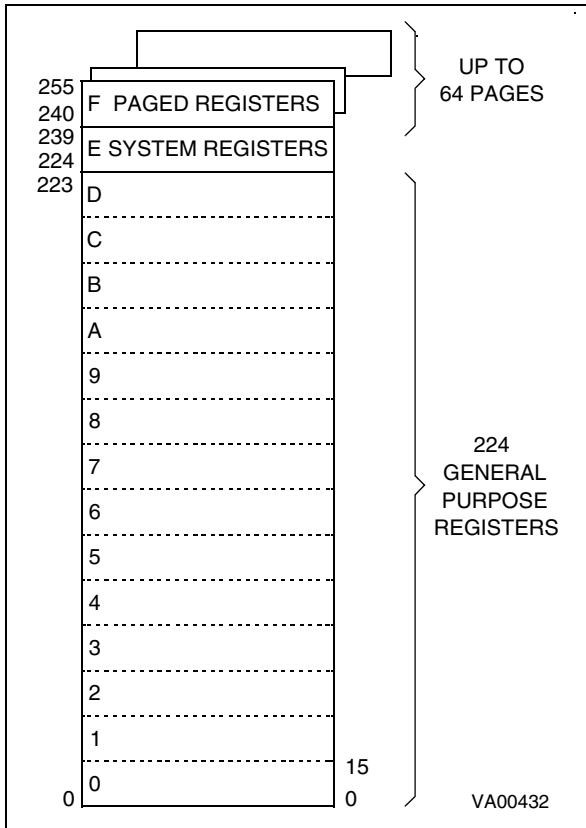

Figure 20. Page Pointer for Group F mapping

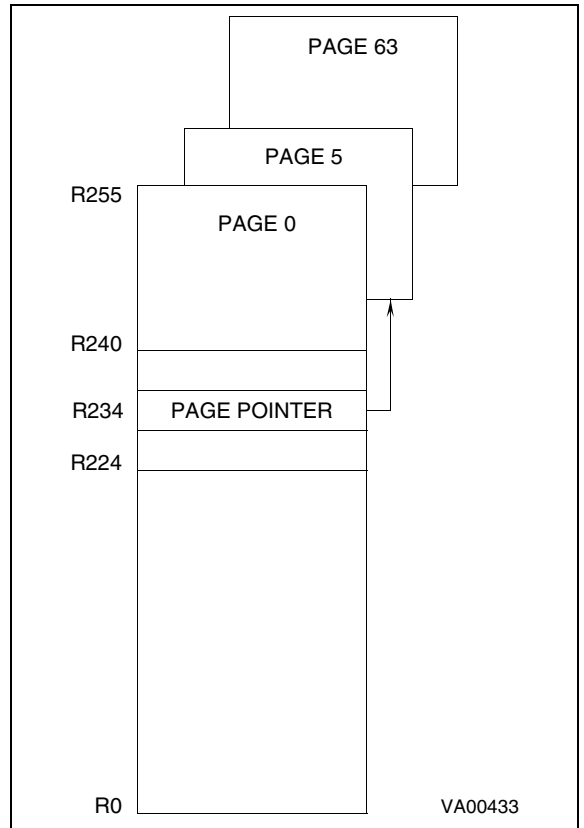
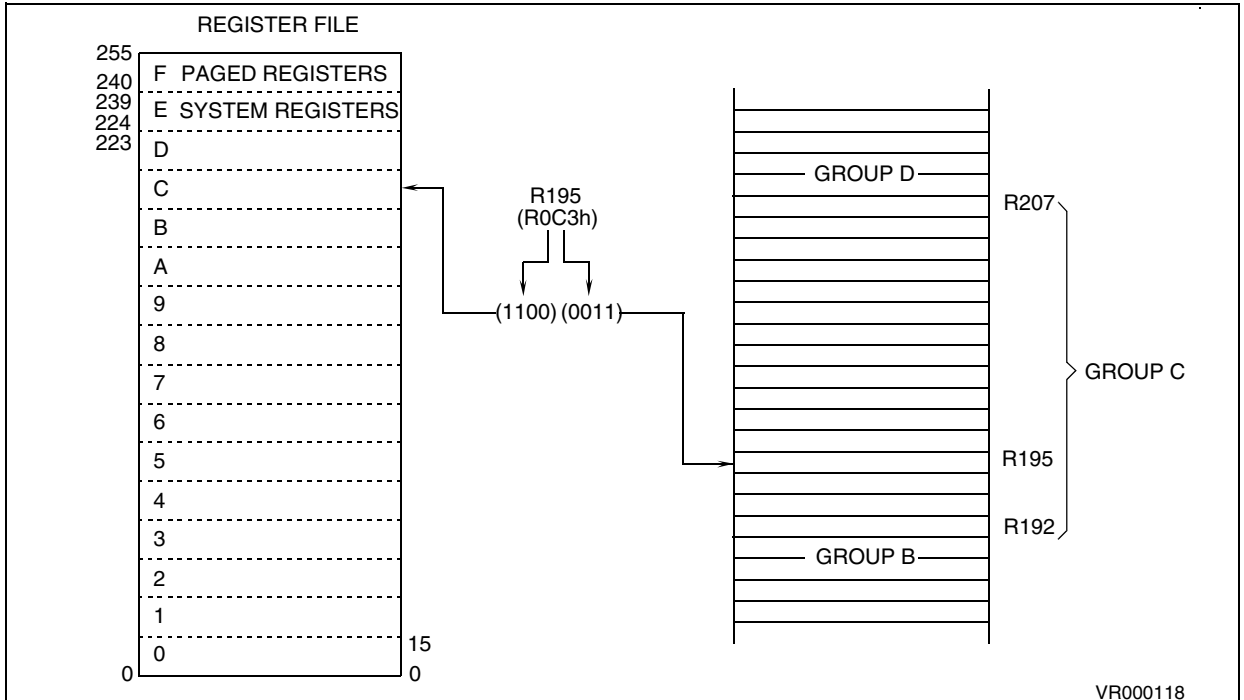

Figure 21. Addressing the Register File



MEMORY SPACES (Cont'd)

2.2.2 Register Addressing

Register File registers, including Group F paged registers (but excluding Group D), may be addressed explicitly by means of a decimal, hexadecimal or binary address; thus R231, RE7h and R11100111b represent the same register (see [Figure 21](#)). Group D registers can only be addressed in Working Register mode.

Note that an upper case “R” is used to denote this direct addressing mode.

Working Registers

Certain types of instruction require that registers be specified in the form “rx”, where x is in the range 0 to 15: these are known as Working Registers.

Note that a lower case “r” is used to denote this indirect addressing mode.

Two addressing schemes are available: a single group of 16 working registers, or two separately mapped groups, each consisting of 8 working registers. These groups may be mapped starting at any 8 or 16 byte boundary in the register file by means of dedicated pointer registers. This technique is described in more detail in Section 2.3.3 Register Pointing Techniques, and illustrated in [Figure 22](#) and in [Figure 23](#).

System Registers

The 16 registers in Group E (R224 to R239) are System registers and may be addressed using any of the register addressing modes. These registers are described in greater detail in Section 2.3 SYSTEM REGISTERS.

Paged Registers

Up to 64 pages, each containing 16 registers, may be mapped to Group F. These are addressed using any register addressing mode, in conjunction with the Page Pointer register, R234, which is one of the System registers. This register selects the page to be mapped to Group F and, once set, does not need to be changed if two or more registers on the same page are to be addressed in succession.

Therefore if the Page Pointer, R234, is set to 5, the instructions:

```
spp #5
ld R242, r4
```

will load the contents of working register r4 into the third register of page 5 (R242).

These paged registers hold data and control information relating to the on-chip peripherals, each peripheral always being associated with the same pages and registers to ensure code compatibility between ST9 devices. The number of these registers therefore depends on the peripherals which are present in the specific ST9 family device. In other words, pages only exist if the relevant peripheral is present.

Table 5. Register File Organization

Hex. Address	Decimal Address	Function	Register File Group
F0-FF	240-255	Paged Registers	Group F
E0-EF	224-239	System Registers	Group E
D0-DF	208-223	General Purpose Registers	Group D
C0-CF	192-207		Group C
B0-BF	176-191		Group B
A0-AF	160-175		Group A
90-9F	144-159		Group 9
80-8F	128-143		Group 8
70-7F	112-127		Group 7
60-6F	96-111		Group 6
50-5F	80-95		Group 5
40-4F	64-79		Group 4
30-3F	48-63		Group 3
20-2F	32-47		Group 2
10-1F	16-31		Group 1
00-0F	00-15		Group 0

2.3 SYSTEM REGISTERS

The System registers are listed in Table 6. They are used to perform all the important system settings. Their purpose is described in the following pages. Refer to the chapter dealing with I/O for a description of the PORT[5:0] Data registers.

Table 6. System Registers (Group E)

R239 (EFh)	SSPLR
R238 (EEh)	SSPHR
R237 (EDh)	USPLR
R236 (ECh)	USPHR
R235 (EBh)	MODE REGISTER
R234 (EAh)	PAGE POINTER REGISTER
R233 (E9h)	REGISTER POINTER 1
R232 (E8h)	REGISTER POINTER 0
R231 (E7h)	FLAG REGISTER
R230 (E6h)	CENTRAL INT. CNTL REG
R229 (E5h)	PORT5 DATA REG.
R228 (E4h)	PORT4 DATA REG.
R227 (E3h)	PORT3 DATA REG.
R226 (E2h)	PORT2 DATA REG.
R225 (E1h)	PORT1 DATA REG.
R224 (E0h)	PORT0 DATA REG.

2.3.1 Central Interrupt Control Register

Please refer to the "INTERRUPT" chapter for a detailed description of the ST9 interrupt philosophy.

CENTRAL INTERRUPT CONTROL REGISTER (CICR)

R230 - Read/Write

Register Group: E (System)

Reset Value: 1000 0111 (87h)

7							0
GCE N	TLIP	TLI	IEN	IAM	CPL2	CPL1	CPL0

Bit 7 = **GCEN**: *Global Counter Enable*.

This bit is the Global Counter Enable of the Multifunction Timers. The GCEN bit is ANDed with the CE bit in the TCR Register (only in devices featuring the MFT Multifunction Timer) in order to enable the Timers when both bits are set. This bit is set after the Reset cycle.

Note: If an MFT is not included in the ST9 device, then this bit has no effect.

Bit 6 = **TLIP**: *Top Level Interrupt Pending*.

This bit is set by hardware when a Top Level Interrupt Request is recognized. This bit can also be set by software to simulate a Top Level Interrupt Request.

0: No Top Level Interrupt pending

1: Top Level Interrupt pending

Bit 5 = **TLI**: *Top Level Interrupt bit*.

0: Top Level Interrupt is acknowledged depending on the TLNM bit in the NICR Register.

1: Top Level Interrupt is acknowledged depending on the IEN and TLNM bits in the NICR Register (described in the Interrupt chapter).

Bit 4 = **IEN**: *Interrupt Enable*.

This bit is cleared by interrupt acknowledgement, and set by interrupt return (*iret*). IEN is modified implicitly by *iret*, *ei* and *di* instructions or by an interrupt acknowledge cycle. It can also be explicitly written by the user, but only when no interrupt is pending. Therefore, the user should execute a *di* instruction (or guarantee by other means that no interrupt request can arrive) before any write operation to the CICR register.

0: Disable all interrupts except Top Level Interrupt.

1: Enable Interrupts

Bit 3 = **IAM**: *Interrupt Arbitration Mode*.

This bit is set and cleared by software to select the arbitration mode.

0: Concurrent Mode

1: Nested Mode.

Bits 2:0 = **CPL[2:0]**: *Current Priority Level*.

These three bits record the priority level of the routine currently running (i.e. the Current Priority Level, CPL). The highest priority level is represented by 000, and the lowest by 111. The CPL bits can be set by hardware or software and provide the reference according to which subsequent interrupts are either left pending or are allowed to interrupt the current interrupt service routine. When the current interrupt is replaced by one of a higher priority, the current priority value is automatically stored until required in the NICR register.

SYSTEM REGISTERS (Cont'd)

2.3.2 Flag Register

The Flag Register contains 8 flags which indicate the CPU status. During an interrupt, the flag register is automatically stored in the system stack area and recalled at the end of the interrupt service routine, thus returning the CPU to its original status.

This occurs for all interrupts and, when operating in nested mode, up to seven versions of the flag register may be stored.

FLAG REGISTER (FLAGR)

R231- Read/Write

Register Group: E (System)

Reset value: 0000 0000 (00h)

7							0
C	Z	S	V	DA	H	-	DP

Bit 7 = **C**: *Carry Flag*.

The carry flag is affected by:

Addition (add, addw, adc, adcw),
 Subtraction (sub, subw, sbc, sbcw),
 Compare (cp, cpw),
 Shift Right Arithmetic (sra, saw),
 Shift Left Arithmetic (sla, slaw),
 Swap Nibbles (swap),
 Rotate (rrc, rrcw, rlc, rlcw, ror, rol),
 Decimal Adjust (da),
 Multiply and Divide (mul, div, divws).

When set, it generally indicates a carry out of the most significant bit position of the register being used as an accumulator (bit 7 for byte operations and bit 15 for word operations).

The carry flag can be set by the Set Carry Flag (scf) instruction, cleared by the Reset Carry Flag (rcf) instruction, and complemented by the Complement Carry Flag (ccf) instruction.

Bit 6 = **Z**: *Zero Flag*. The Zero flag is affected by:

Addition (add, addw, adc, adcw),
 Subtraction (sub, subw, sbc, sbcw),
 Compare (cp, cpw),
 Shift Right Arithmetic (sra, saw),
 Shift Left Arithmetic (sla, slaw),
 Swap Nibbles (swap),
 Rotate (rrc, rrcw, rlc, rlcw, ror, rol),
 Decimal Adjust (da),
 Multiply and Divide (mul, div, divws),
 Logical (and, andw, or, orw, xor, xorw, cpl),
 Increment and Decrement (inc, incw, dec,

decw),

Test (tm, tmw, tcm, tcmw, btset).

In most cases, the Zero flag is set when the contents of the register being used as an accumulator become zero, following one of the above operations.

Bit 5 = **S**: *Sign Flag*.

The Sign flag is affected by the same instructions as the Zero flag.

The Sign flag is set when bit 7 (for a byte operation) or bit 15 (for a word operation) of the register used as an accumulator is one.

Bit 4 = **V**: *Overflow Flag*.

The Overflow flag is affected by the same instructions as the Zero and Sign flags.

When set, the Overflow flag indicates that a two's-complement number, in a result register, is in error, since it has exceeded the largest (or is less than the smallest), number that can be represented in two's-complement notation.

Bit 3 = **DA**: *Decimal Adjust Flag*.

The DA flag is used for BCD arithmetic. Since the algorithm for correcting BCD operations is different for addition and subtraction, this flag is used to specify which type of instruction was executed last, so that the subsequent Decimal Adjust (da) operation can perform its function correctly. The DA flag cannot normally be used as a test condition by the programmer.

Bit 2 = **H**: *Half Carry Flag*.

The H flag indicates a carry out of (or a borrow into) bit 3, as the result of adding or subtracting two 8-bit bytes, each representing two BCD digits. The H flag is used by the Decimal Adjust (da) instruction to convert the binary result of a previous addition or subtraction into the correct BCD result. Like the DA flag, this flag is not normally accessed by the user.

Bit 1 = Reserved bit (must be 0).

Bit 0 = **DP**: *Data/Program Memory Flag*.

This bit indicates the memory area addressed. Its value is affected by the Set Data Memory (sdm) and Set Program Memory (spm) instructions. Refer to the Memory Management Unit for further details.

SYSTEM REGISTERS (Cont'd)

If the bit is set, data is accessed using the Data Pointers (DPRs registers), otherwise it is pointed to by the Code Pointer (CSR register); therefore, the user initialization routine must include a `Sdm` instruction. Note that code is always pointed to by the Code Pointer (CSR).

Note: In the current ST9 devices, the DP flag is only for compatibility with software developed for the first generation of ST9 devices. With the single memory addressing space, its use is now redundant. It must be kept to 1 with a `Sdm` instruction at the beginning of the program to ensure a normal use of the different memory pointers.

2.3.3 Register Pointing Techniques

Two registers within the System register group, are used as pointers to the working registers. Register Pointer 0 (R232) may be used on its own as a single pointer to a 16-register working space, or in conjunction with Register Pointer 1 (R233), to point to two separate 8-register spaces.

For the purpose of register pointing, the 16 register groups of the register file are subdivided into 32 8-register blocks. The values specified with the Set Register Pointer instructions refer to the blocks to be pointed to in twin 8-register mode, or to the lower 8-register block location in single 16-register mode.

The Set Register Pointer instructions `srp`, `srp0` and `srp1` automatically inform the CPU whether the Register File is to operate in single 16-register mode or in twin 8-register mode. The `srp` instruction selects the single 16-register group mode and

specifies the location of the lower 8-register block, while the `srp0` and `srp1` instructions automatically select the twin 8-register group mode and specify the locations of each 8-register block.

There is no limitation on the order or position of these register groups, other than that they must start on an 8-register boundary in twin 8-register mode, or on a 16-register boundary in single 16-register mode.

The block number should always be an even number in single 16-register mode. The 16-register group will always start at the block whose number is the nearest even number equal to or lower than the block number specified in the `srp` instruction. Avoid using odd block numbers, since this can be confusing if twin mode is subsequently selected.

Thus:

`srp #3` will be interpreted as `srp #2` and will allow using R16 ..R31 as r0 .. r15.

In single 16-register mode, the working registers are referred to as `r0` to `r15`. In twin 8-register mode, registers `r0` to `r7` are in the block pointed to by RP0 (by means of the `srp0` instruction), while registers `r8` to `r15` are in the block pointed to by RP1 (by means of the `srp1` instruction).

Caution: *Group D registers can only be accessed as working registers using the Register Pointers, or by means of the Stack Pointers. They cannot be addressed explicitly in the form "Rxxx".*

SYSTEM REGISTERS (Cont'd)**POINTER 0 REGISTER (RP0)**

R232 - Read/Write

Register Group: E (System)

Reset Value: xxxx xx00 (xxh)

7							0
RG4	RG3	RG2	RG1	RG0	RPS	0	0

Bits 7:3 = **RG[4:0]**: *Register Group number*.
 These bits contain the number (in the range 0 to 31) of the register block specified in the `srp0` or `srp` instructions. In single 16-register mode the number indicates the lower of the two 8-register blocks to which the 16 working registers are to be mapped, while in twin 8-register mode it indicates the 8-register block to which `r0` to `r7` are to be mapped.

Bit 2 = **RPS**: *Register Pointer Selector*.

This bit is set by the instructions `srp0` and `srp1` to indicate that the twin register pointing mode is selected. The bit is reset by the `srp` instruction to indicate that the single register pointing mode is selected.

0: Single register pointing mode

1: Twin register pointing mode

Bits 1:0: Reserved. Forced by hardware to zero.

POINTER 1 REGISTER (RP1)

R233 - Read/Write

Register Group: E (System)

Reset Value: xxxx xx00 (xxh)

7							0
RG4	RG3	RG2	RG1	RG0	RPS	0	0

This register is only used in the twin register pointing mode. When using the single register pointing mode, or when using only one of the twin register groups, the RP1 register must be considered as RESERVED and may NOT be used as a general purpose register.

Bits 7:3 = **RG[4:0]**: *Register Group number*.
 These bits contain the number (in the range 0 to 31) of the 8-register block specified in the `srp1` instruction, to which `r8` to `r15` are to be mapped.

Bit 2 = **RPS**: *Register Pointer Selector*.

This bit is set by the `srp0` and `srp1` instructions to indicate that the twin register pointing mode is selected. The bit is reset by the `srp` instruction to indicate that the single register pointing mode is selected.

0: Single register pointing mode

1: Twin register pointing mode

Bits 1:0: Reserved. Forced by hardware to zero.

SYSTEM REGISTERS (Cont'd)

Figure 22. Pointing to a single group of 16 registers

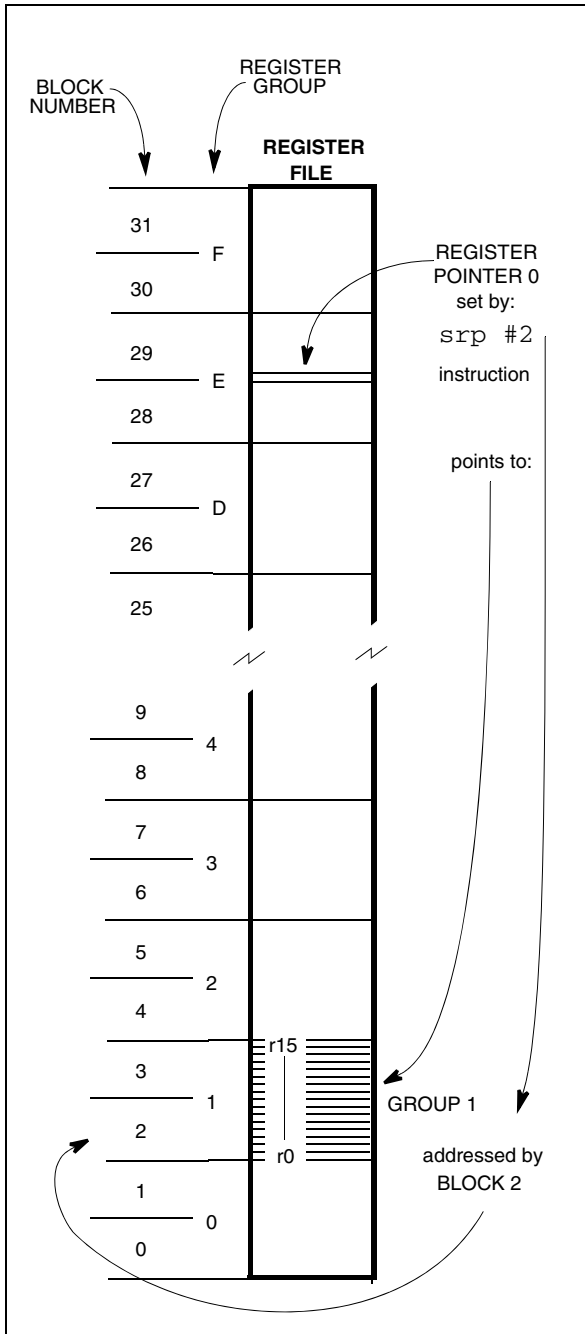
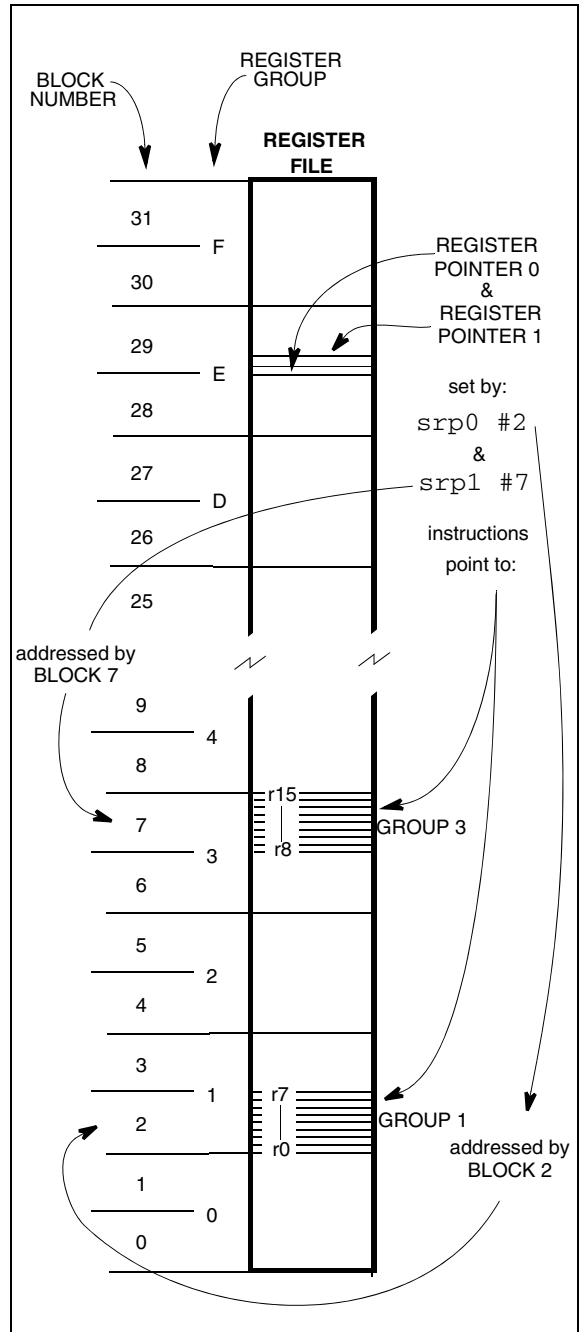

Figure 23. Pointing to two groups of 8 registers



SYSTEM REGISTERS (Cont'd)**2.3.4 Paged Registers**

Up to 64 pages, each containing 16 registers, may be mapped to Group F. These paged registers hold data and control information relating to the on-chip peripherals, each peripheral always being associated with the same pages and registers to ensure code compatibility between ST9 devices. The number of these registers depends on the peripherals present in the specific ST9 device. In other words, pages only exist if the relevant peripheral is present.

The paged registers are addressed using the normal register addressing modes, in conjunction with the Page Pointer register, R234, which is one of the System registers. This register selects the page to be mapped to Group F and, once set, does not need to be changed if two or more registers on the same page are to be addressed in succession.

Thus the instructions:

```
spp #5
ld R242, r4
```

will load the contents of working register r4 into the third register of page 5 (R242).

Warning: During an interrupt, the PPR register is not saved automatically in the stack. If needed, it should be saved/restored by the user within the interrupt routine.

PAGE POINTER REGISTER (PPR)

R234 - Read/Write

Register Group: E (System)

Reset value: xxxx xx00 (xxh)

7							0
PP5	PP4	PP3	PP2	PP1	PP0	0	0

Bits 7:2 = **PP[5:0]: Page Pointer.**

These bits contain the number (in the range 0 to 63) of the page specified in the `spp` instruction. Once the page pointer has been set, there is no need to refresh it unless a different page is required.

Bits 1:0: Reserved. Forced by hardware to 0.

2.3.5 Mode Register

The Mode Register allows control of the following operating parameters:

- Selection of internal or external System and User Stack areas,

- Management of the clock frequency,
- Enabling of Bus request and Wait signals when interfacing to external memory.

MODE REGISTER (MODER)

R235 - Read/Write

Register Group: E (System)

Reset value: 1110 0000 (E0h)

7							0
SSP	USP	DIV2	PRS2	PRS1	PRS0	BRQEN	HIMP

Bit 7 = **SSP: System Stack Pointer.**

This bit selects an internal or external System Stack area.

- 0: External system stack area, in memory space.
- 1: Internal system stack area, in the Register File (reset state).

Bit 6 = **USP: User Stack Pointer.**

This bit selects an internal or external User Stack area.

- 0: External user stack area, in memory space.
- 1: Internal user stack area, in the Register File (reset state).

Bit 5 = **DIV2: Crystal Oscillator Clock Divided by 2.**

This bit controls the divide-by-2 circuit operating on the crystal oscillator clock (CLOCK1).

- 0: Clock divided by 1
- 1: Clock divided by 2

Bits 4:2 = **PRS[2:0]: CPUCLK Prescaler.**

These bits load the prescaler division factor for the internal clock (INTCLK). The prescaler factor selects the internal clock frequency, which can be divided by a factor from 1 to 8. Refer to the Reset and Clock Control chapter for further information.

Bit 1 = **BRQEN: Bus Request Enable.**

- 0: External Memory Bus Request disabled
- 1: External Memory Bus Request enabled on $\overline{\text{BREQ}}$ pin (where available).

Note: Disregard this bit if $\overline{\text{BREQ}}$ pin is not available.

Bit 0 = **HIMP: High Impedance Enable.**

When a port is programmed as Address and Data lines to interface external Memory, these lines and the Memory interface control lines (AS, DS, R/W) can be forced into the High Impedance state.

- 0: External memory interface lines in normal state
- 1: High Impedance state.

Note: Setting the HIMP bit is recommended for noise reduction when only internal Memory is used.

If the memory access ports are declared as an address AND as an I/O port (for example: P10... P14 = Address, and P15... P17 = I/O), the HIMP bit has no effect on the I/O lines.

2.3.6 Stack Pointers

Two separate, double-register stack pointers are available: the System Stack Pointer and the User Stack Pointer, both of which can address registers or memory.

The stack pointers point to the “bottom” of the stacks which are filled using the push commands and emptied using the pop commands. The stack pointer is automatically pre-decremented when data is “pushed” in and post-incremented when data is “popped” out.

The push and pop commands used to manage the System Stack may be addressed to the User Stack by adding the suffix “u”. To use a stack instruction for a word, the suffix “w” is added. These suffixes may be combined.

When bytes (or words) are “popped” out from a stack, the contents of the stack locations are unchanged until fresh data is loaded. Thus, when data is “popped” from a stack area, the stack contents remain unchanged.

Note: Instructions such as: `pushuw RR236` or `pushw RR238`, as well as the corresponding `pop` instructions (where R236 & R237, and R238 & R239 are themselves the user and system stack pointers respectively), must not be used, since the pointer values are themselves automatically changed by the `push` or `pop` instruction, thus corrupting their value.

System Stack

The System Stack is used for the temporary storage of system and/or control data, such as the Flag register and the Program counter.

The following automatically push data onto the System Stack:

– Interrupts

When entering an interrupt, the PC and the Flag Register are pushed onto the System Stack. If the ENCSR bit in the EMR2 register is set, then the Code Segment Register is also pushed onto the System Stack.

– Subroutine Calls

When a `call` instruction is executed, only the PC is pushed onto stack, whereas when a `calls` instruction (call segment) is executed, both the PC and the Code Segment Register are pushed onto the System Stack.

– Link Instruction

The `link` or `linku` instructions create a C language stack frame of user-defined length in the System or User Stack.

All of the above conditions are associated with their counterparts, such as return instructions, which pop the stored data items off the stack.

User Stack

The User Stack provides a totally user-controlled stacking area.

The User Stack Pointer consists of two registers, R236 and R237, which are both used for addressing a stack in memory. When stacking in the Register File, the User Stack Pointer High Register, R236, becomes redundant but must be considered as reserved.

Stack Pointers

Both System and User stacks are pointed to by double-byte stack pointers. Stacks may be set up in RAM or in the Register File. Only the lower byte will be required if the stack is in the Register File. The upper byte must then be considered as reserved and must not be used as a general purpose register.

The stack pointer registers are located in the System Group of the Register File, this is illustrated in [Table 6](#).

Stack Location

Care is necessary when managing stacks as there is no limit to stack sizes apart from the bottom of any address space in which the stack is placed. Consequently programmers are advised to use a stack pointer value as high as possible, particularly when using the Register File as a stacking area.

Group D is a good location for a stack in the Register File, since it is the highest available area. The stacks may be located anywhere in the first 14 groups of the Register File (internal stacks) or in RAM (external stacks).

Note. Stacks must not be located in the Paged Register Group or in the System Register Group.

2.4 MEMORY ORGANIZATION

Code and data are accessed within the same linear address space. All of the physically separate memory areas, including the internal ROM, internal RAM and external memory are mapped in a common address space.

The ST9 provides a total addressable memory space of 4 Mbytes. This address space is arranged as 64 segments of 64 Kbytes; each segment is again subdivided into four 16 Kbyte pages.

The mapping of the various memory areas (internal RAM or ROM, external memory) differs from device to device. Each 64-Kbyte physical memory segment is mapped either internally or externally; if the memory is internal and smaller than 64 Kbytes, the remaining locations in the 64-Kbyte segment are not used (reserved).

Refer to the Register and Memory Map Chapter for more details on the memory map.

2.5 MEMORY MANAGEMENT UNIT

The CPU Core includes a Memory Management Unit (MMU) which must be programmed to perform memory accesses (even if external memory is not used).

The MMU is controlled by 7 registers and 2 bits (ENCSR and DPRREM) present in EMR2, which may be written and read by the user program. These registers are mapped within group F, Page 21 of the Register File. The 7 registers may be

sub-divided into 2 main groups: a first group of four 8-bit registers (DPR[3:0]), and a second group of three 6-bit registers (CSR, ISR, and DMASR). The first group is used to extend the address during Data Memory access (DPR[3:0]). The second is used to manage Program and Data Memory accesses during Code execution (CSR), Interrupts Service Routines (ISR or CSR), and DMA transfers (DMASR or ISR).

Figure 26. Page 21 Registers

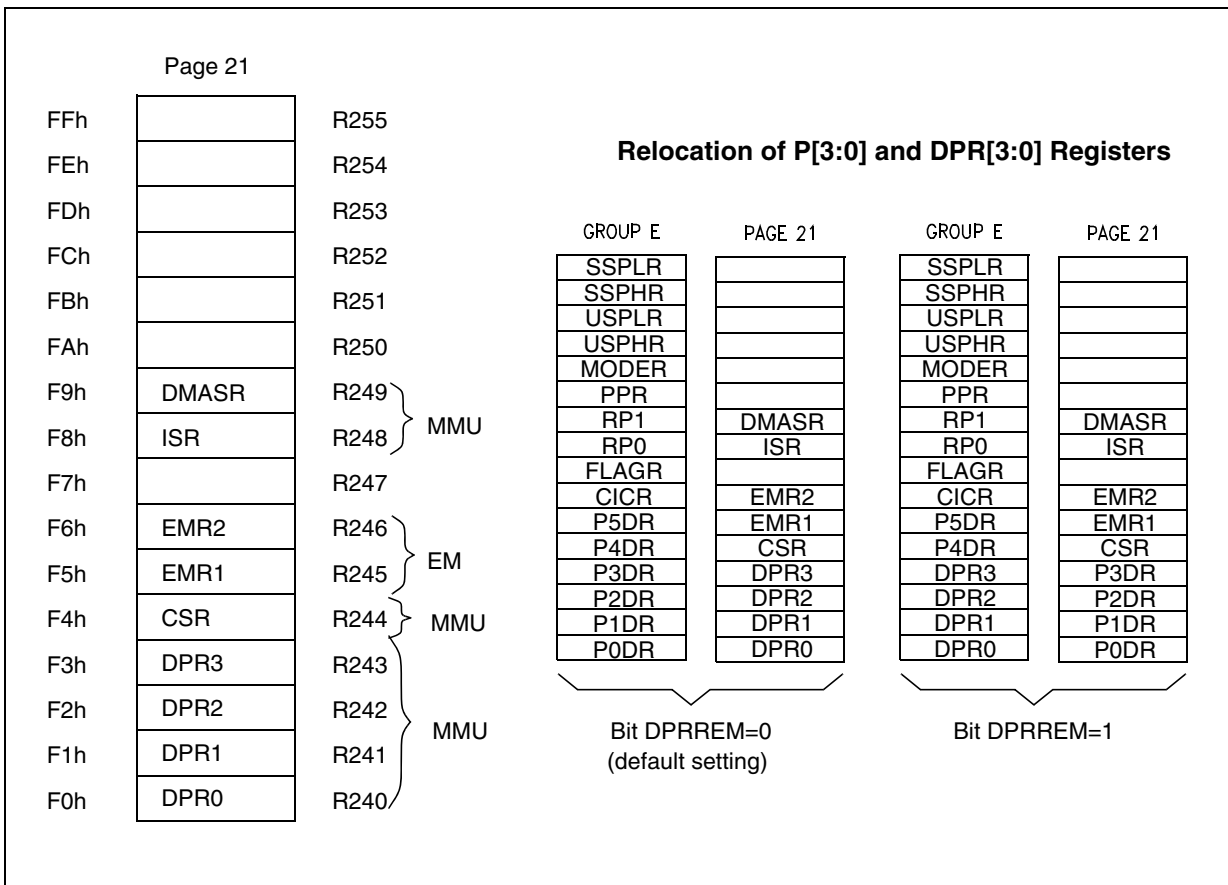

2.6 ADDRESS SPACE EXTENSION

To manage 4 Mbytes of addressing space, it is necessary to have 22 address bits. The MMU adds 6 bits to the usual 16-bit address, thus translating a 16-bit virtual address into a 22-bit physical address. There are 2 different ways to do this depending on the memory involved and on the operation being performed.

2.6.1 Addressing 16-Kbyte Pages

This extension mode is implicitly used to address Data memory space if no DMA is being performed.

The Data memory space is divided into 4 pages of 16 Kbytes. Each one of the four 8-bit registers (DPR[3:0], Data Page Registers) selects a different 16-Kbyte page. The DPR registers allow access to the entire memory space which contains 256 pages of 16 Kbytes.

Data paging is performed by extending the 14 LSB of the 16-bit address with the contents of a DPR register. The two MSBs of the 16-bit address are interpreted as the identification number of the DPR register to be used. Therefore, the DPR registers

are involved in the following virtual address ranges:

- DPR0: from 0000h to 3FFFh;
- DPR1: from 4000h to 7FFFh;
- DPR2: from 8000h to BFFFh;
- DPR3: from C000h to FFFFh.

The contents of the selected DPR register specify one of the 256 possible data memory pages. This 8-bit data page number, in addition to the remaining 14-bit page offset address forms the physical 22-bit address (see Figure 27).

A DPR register cannot be modified via an addressing mode that uses the same DPR register. For instance, the instruction “POPW DPR0” is legal only if the stack is kept either in the register file or in a memory location above 8000h, where DPR2 and DPR3 are used. Otherwise, since DPR0 and DPR1 are modified by the instruction, unpredictable behaviour could result.

Figure 27. Addressing via DPR[3:0]

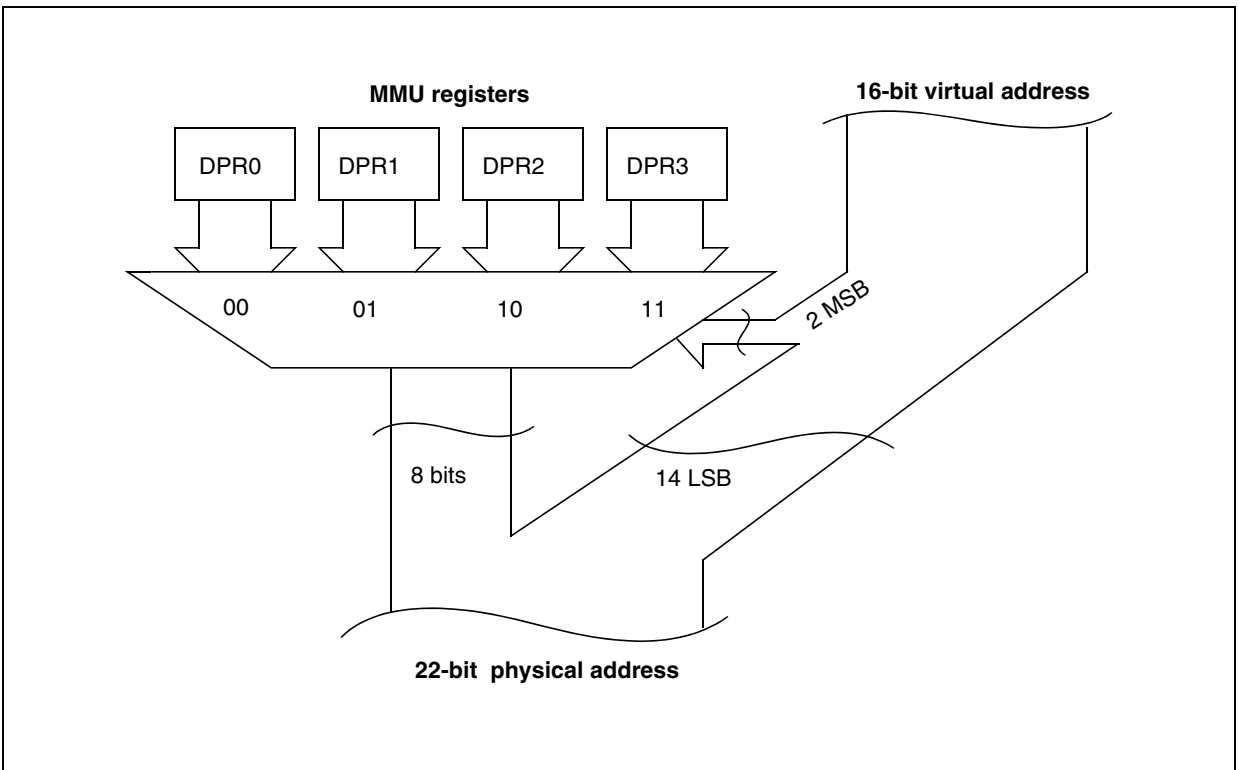

ADDRESS SPACE EXTENSION (Cont'd)

2.6.2 Addressing 64-Kbyte Segments

This extension mode is used to address Data memory space during a DMA and Program memory space during any code execution (normal code and interrupt routines).

Three registers are used: CSR, ISR, and DMASR. The 6-bit contents of one of the registers CSR, ISR, or DMASR define one out of 64 Memory segments of 64 Kbytes within the 4 Mbytes address space. The register contents represent the 6 MSBs of the memory address, whereas the 16 LSBs of the address (intra-segment address) are given by the virtual 16-bit address (see [Figure 28](#)).

2.7 MMU REGISTERS

The MMU uses 7 registers mapped into Group F, Page 21 of the Register File and 2 bits of the EMR2 register.

Most of these registers do not have a default value after reset.

2.7.1 DPR[3:0]: Data Page Registers

The DPR[3:0] registers allow access to the entire 4 Mbyte memory space composed of 256 pages of 16 Kbytes.

2.7.1.1 Data Page Register Relocation

If these registers are to be used frequently, they may be relocated in register group E, by programming bit 5 of the EMR2-R246 register in page 21. If this bit is set, the DPR[3:0] registers are located at R224-227 in place of the Port 0-3 Data Registers, which are re-mapped to the default DPR's locations: R240-243 page 21.

Data Page Register relocation is illustrated in [Figure 26](#).

Figure 28. Addressing via CSR, ISR, and DMASR

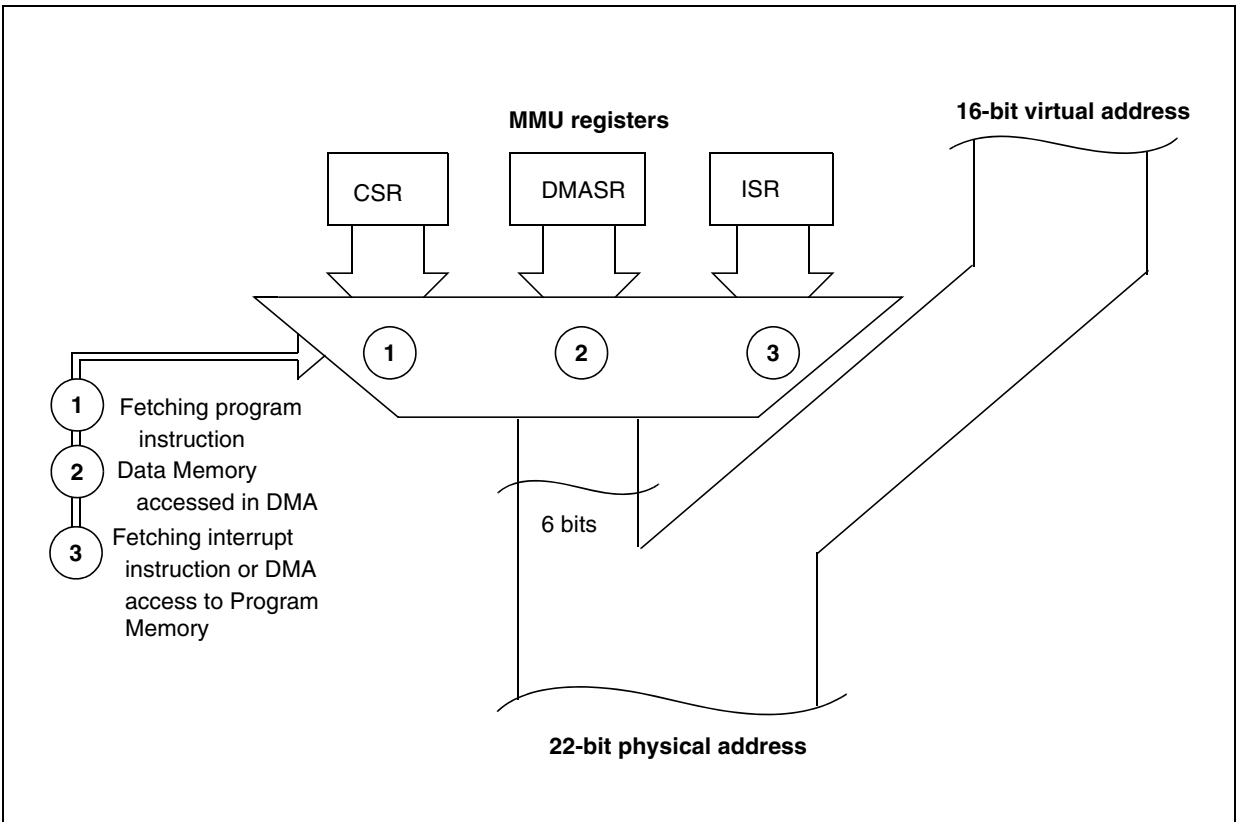

MMU REGISTERS (Cont'd)

DATA PAGE REGISTER 0 (DPR0)

R240 - Read/Write
 Register Page: 21
 Reset value: undefined

This register is relocated to R224 if EMR2.5 is set.

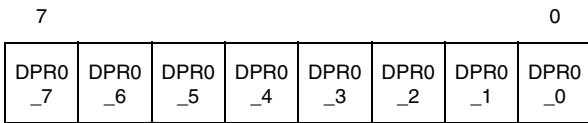

Bits 7:0 = **DPR0_[7:0]**: These bits define the 16-Kbyte Data Memory page number. They are used as the most significant address bits (A21-14) to extend the address during a Data Memory access. The DPR0 register is used when addressing the virtual address range 0000h-3FFFh.

DATA PAGE REGISTER 1 (DPR1)

R241 - Read/Write
 Register Page: 21
 Reset value: undefined

This register is relocated to R225 if EMR2.5 is set.

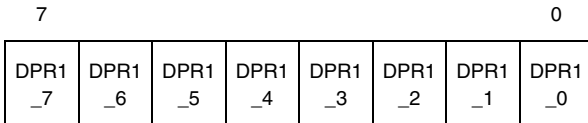

Bits 7:0 = **DPR1_[7:0]**: These bits define the 16-Kbyte Data Memory page number. They are used as the most significant address bits (A21-14) to extend the address during a Data Memory access. The DPR1 register is used when addressing the virtual address range 4000h-7FFFh.

DATA PAGE REGISTER 2 (DPR2)

R242 - Read/Write
 Register Page: 21
 Reset value: undefined

This register is relocated to R226 if EMR2.5 is set.

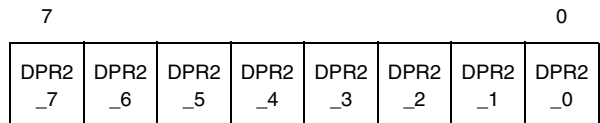

Bits 7:0 = **DPR2_[7:0]**: These bits define the 16-Kbyte Data memory page. They are used as the most significant address bits (A21-14) to extend the address during a Data memory access. The DPR2 register is involved when the virtual address is in the range 8000h-BFFFh.

DATA PAGE REGISTER 3 (DPR3)

R243 - Read/Write
 Register Page: 21
 Reset value: undefined

This register is relocated to R227 if EMR2.5 is set.

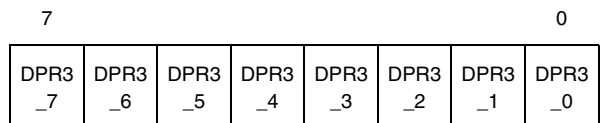

Bits 7:0 = **DPR3_[7:0]**: These bits define the 16-Kbyte Data memory page. They are used as the most significant address bits (A21-14) to extend the address during a Data memory access. The DPR3 register is involved when the virtual address is in the range C000h-FFFFh.

MMU REGISTERS (Cont'd)**2.7.2 CSR: Code Segment Register**

This register selects the 64-Kbyte code segment being used at run-time to access instructions. It can also be used to access data if the `spm` instruction has been executed (or `ldpp`, `ldpd`, `lddp`). Only the 6 LSBs of the CSR register are implemented, and bits 6 and 7 are reserved. The CSR register allows access to the entire memory space, divided into 64 segments of 64 Kbytes.

To generate the 22-bit Program memory address, the contents of the CSR register is directly used as the 6 MSBs, and the 16-bit virtual address as the 16 LSBs.

Note: The CSR register should only be read and not written for data operations (there are some exceptions which are documented in the following paragraph). It is, however, modified either directly by means of the `jps` and `calls` instructions, or indirectly via the stack, by means of the `rets` instruction.

CODE SEGMENT REGISTER (CSR)

R244 - Read/Write

Register Page: 21

Reset value: 0000 0000 (00h)

7							0
0	0	CSR_5	CSR_4	CSR_3	CSR_2	CSR_1	CSR_0

Bits 7:6 = Reserved, keep in reset state.

Bits 5:0 = **CSR_[5:0]**: These bits define the 64-Kbyte memory segment (among 64) which contains the code being executed. These bits are used as the most significant address bits (A21-16).

2.7.3 ISR: Interrupt Segment Register**INTERRUPT SEGMENT REGISTER (ISR)**

R248 - Read/Write

Register Page: 21

Reset value: undefined

7							0
0	0	ISR_5	ISR_4	ISR_3	ISR_2	ISR_1	ISR_0

ISR and ENCSR bit (EMR2 register) are also described in the chapter relating to Interrupts, please refer to this description for further details.

Bits 7:6 = Reserved, keep in reset state.

Bits 5:0 = **ISR_[5:0]**: These bits define the 64-Kbyte memory segment (among 64) which contains the interrupt vector table and the code for interrupt service routines and DMA transfers (when the PS bit of the DAPR register is reset). These bits are used as the most significant address bits (A21-16). The ISR is used to extend the address space in two cases:

- Whenever an interrupt occurs: ISR points to the 64-Kbyte memory segment containing the interrupt vector table and the interrupt service routine code. See also the Interrupts chapter.
- During DMA transactions between the peripheral and memory when the PS bit of the DAPR register is reset : ISR points to the 64 K-byte Memory segment that will be involved in the DMA transaction.

2.7.4 DMASR: DMA Segment Register**DMA SEGMENT REGISTER (DMASR)**

R249 - Read/Write

Register Page: 21

Reset value: undefined

7							0
0	0	DMA SR_5	DMA SR_4	DMA SR_3	DMA SR_2	DMA SR_1	DMA SR_0

Bits 7:6 = Reserved, keep in reset state.

Bits 5:0 = **DMASR_[5:0]**: These bits define the 64-Kbyte Memory segment (among 64) used when a DMA transaction is performed between the peripheral's data register and Memory, with the PS bit of the DAPR register set. These bits are used as the most significant address bits (A21-16). If the PS bit is reset, the ISR register is used to extend the address.

MMU REGISTERS (Cont'd)

Figure 29. Memory Addressing Scheme (example)

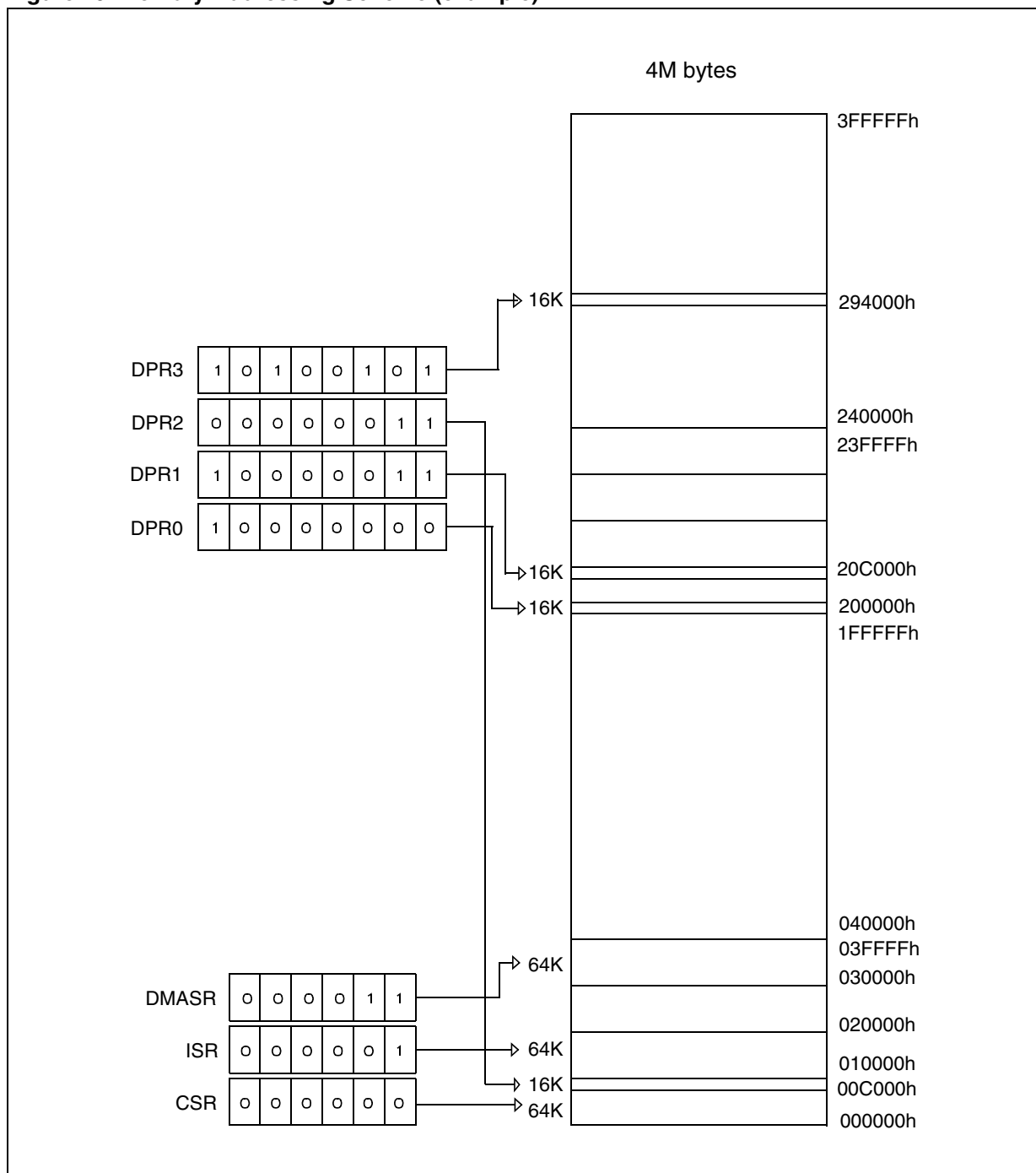

2.8 MMU USAGE

2.8.1 Normal Program Execution

Program memory is organized as a set of 64-Kbyte segments. The program can span as many segments as needed, but a procedure cannot stretch across segment boundaries. `jps`, `calls` and `rets` instructions, which automatically modify the CSR, must be used to jump across segment boundaries. Writing to the CSR is forbidden during normal program execution because it is not synchronized with the opcode fetch. This could result in fetching the first byte of an instruction from one memory segment and the second byte from another. Writing to the CSR is allowed when it is not being used, i.e. during an interrupt service routine if ENCSR is reset.

Note that a routine must always be called in the same way, i.e. either always with `call` or always with `calls`, depending on whether the routine ends with `ret` or `rets`. This means that if the routine is written without prior knowledge of the location of other routines which call it, and all the program code does not fit into a single 64-Kbyte segment, then `calls/rets` should be used.

In typical microcontroller applications, less than 64 Kbytes of RAM are used, so the four Data space pages are normally sufficient, and no change of DPR[3:0] is needed during Program execution. It may be useful however to map part of the ROM into the data space if it contains strings, tables, bit maps, etc.

If there is to be frequent use of paging, the user can set bit 5 (DPRREM) in register R246 (EMR2) of Page 21. This swaps the location of registers DPR[3:0] with that of the data registers of Ports 0-3. In this way, DPR registers can be accessed without the need to save/set/restore the Page Pointer Register. Port registers are therefore moved to page 21. Applications that require a lot of paging typically use more than 64 Kbytes of external memory, and as ports 0, 1 and 9 are required to address it, their data registers are unused.

2.8.2 Interrupts

The ISR register has been created so that the interrupt routines may be found by means of the same vector table even after a segment jump/call.

When an interrupt occurs, the CPU behaves in one of 2 ways, depending on the value of the ENCSR bit in the EMR2 register (R246 on Page 21).

If this bit is reset (default condition), the CPU works in original ST9 compatibility mode. For the duration of the interrupt service routine, the ISR is

used instead of the CSR, and the interrupt stack frame is kept exactly as in the original ST9 (only the PC and flags are pushed). This avoids the need to save the CSR on the stack in the case of an interrupt, ensuring a fast interrupt response time. The drawback is that it is not possible for an interrupt service routine to perform segment `calls/jps`: these instructions would update the CSR, which, in this case, is not used (ISR is used instead). The code size of all interrupt service routines is thus limited to 64 Kbytes.

If, instead, bit 6 of the EMR2 register is set, the ISR is used only to point to the interrupt vector table and to initialize the CSR at the beginning of the interrupt service routine: the old CSR is pushed onto the stack together with the PC and the flags, and then the CSR is loaded with the ISR. In this case, an `iret` will also restore the CSR from the stack. This approach lets interrupt service routines access the whole 4-Mbyte address space. The drawback is that the interrupt response time is slightly increased, because of the need to also save the CSR on the stack. Compatibility with the original ST9 is also lost in this case, because the interrupt stack frame is different; this difference, however, would not be noticeable for a vast majority of programs.

Data memory mapping is independent of the value of bit 6 of the EMR2 register, and remains the same as for normal code execution: the stack is the same as that used by the main program, as in the ST9. If the interrupt service routine needs to access additional Data memory, it must save one (or more) of the DPRs, load it with the needed memory page and restore it before completion.

2.8.3 DMA

Depending on the PS bit in the DAPR register (see DMA chapter) DMA uses either the ISR or the DMASR for memory accesses: this guarantees that a DMA will always find its memory segment(s), no matter what segment changes the application has performed. Unlike interrupts, DMA transactions cannot save/restore paging registers, so a dedicated segment register (DMASR) has been created. Having only one register of this kind means that all DMA accesses should be programmed in one of the two following segments: the one pointed to by the ISR (when the PS bit of the DAPR register is reset), and the one referenced by the DMASR (when the PS bit is set).

3 SINGLE VOLTAGE FLASH & E³™ (EMULATED EEPROM)

3.1 INTRODUCTION

The Flash circuitry contains one array divided in two main parts that can each be read independently. The first part contains the main Flash array for code storage, a reserved array (TestFlash) for system routines and a 128-byte area available as one time programmable memory (OTP). The sec-

ond part contains the two dedicated Flash sectors used for EEPROM Hardware Emulation.

The write operations of the two parts are managed by an embedded Program/Erase Controller. Through a dedicated RAM buffer the Flash and the E³™ can be written in blocks of 16 bytes.

Figure 30. Flash Memory Structure (Example for 64K Flash device)

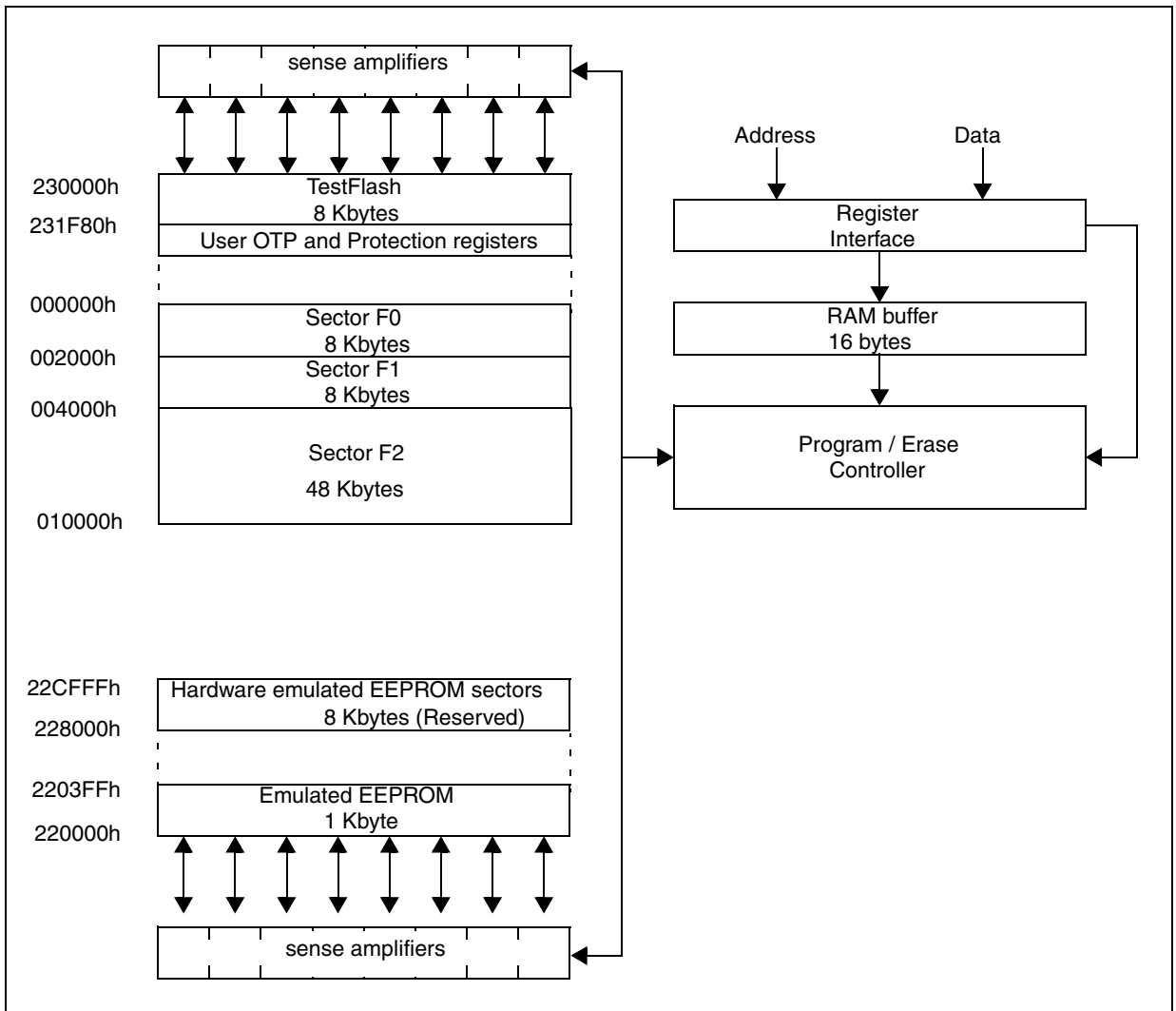
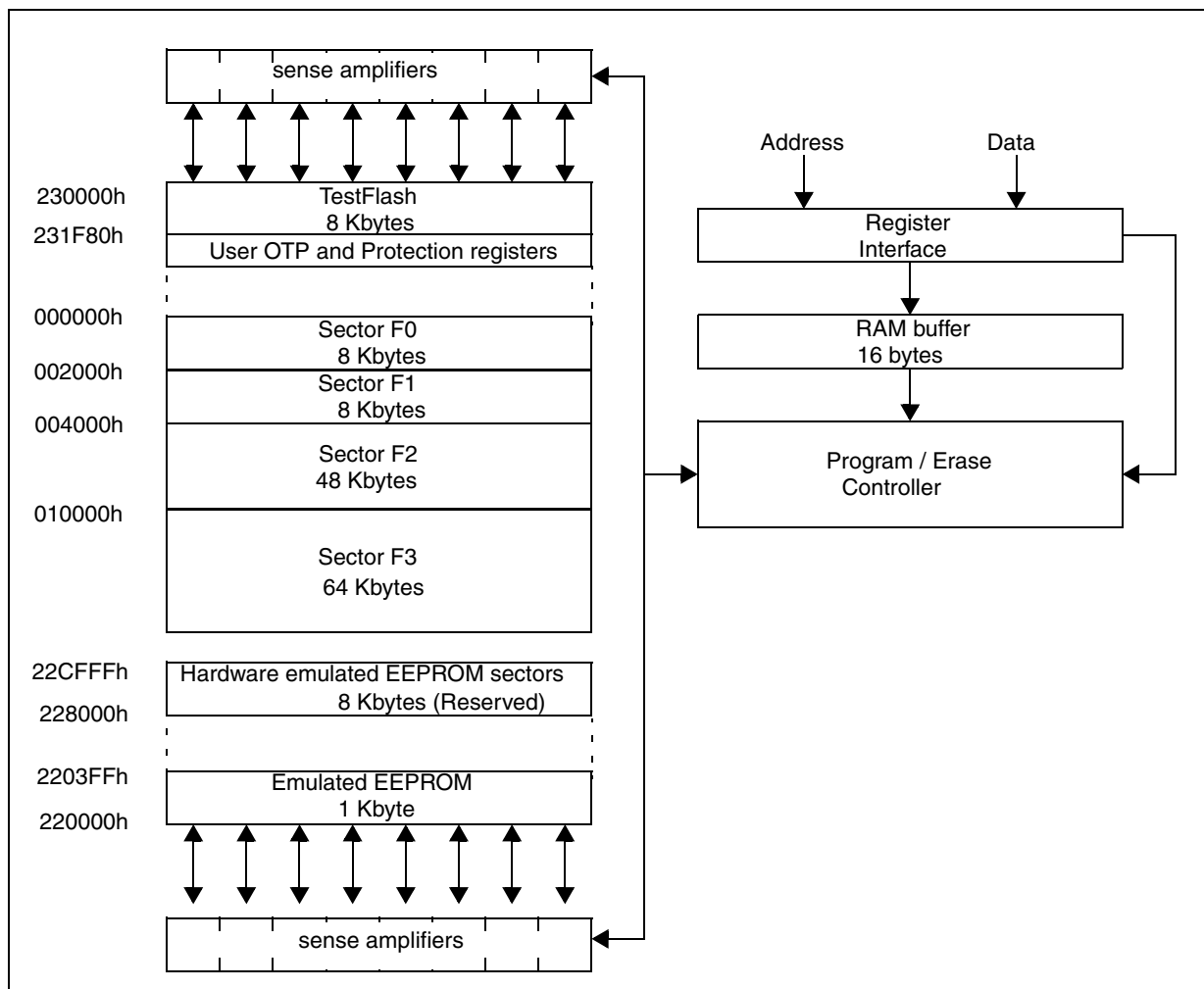

Figure 31. Flash Memory Structure (Example for 128K Flash device)



3.2 FUNCTIONAL DESCRIPTION

3.2.1 Structure

The memory is composed of three parts:

- a sector with the system routines (TestFlash) and the user OTP area
- 4 main sectors for code
- an emulated EEPROM

124 bytes are available to the user as an OTP area. The user can program these bytes, but cannot erase them.

3.2.2 EEPROM Emulation

A hardware EEPROM emulation is implemented using special flash sectors to emulate an EEPROM memory. This E³™ is directly addressed from 220000h to 2203FFh.

(For more details on hardware EEPROM emulation, see application note AN1152)

Table 7. Memory Structure for 64K Flash device

Sector	Addresses	Max Size
TestFlash (TF) (Reserved)	230000h to 231F7Fh	8064 bytes
OTP Area	231F80h to 231FFBh	124 bytes
Protection Registers (reserved)	231FFCh to 231FFFh	4 bytes
Flash 0 (F0)	000000h to 001FFFh	8 Kbytes
Flash 1 (F1)	002000h to 003FFFh	8 Kbytes
Flash 2 (F2)	004000h to 00FFFFh	48 Kbytes
Hardware Emulated EEPROM sectors (reserved)	228000h to 22CFFFh	8 Kbytes
Emulated EEPROM	220000h to 2203FFh	1 Kbyte

Table 8. Memory Structure for 128K Flash device

Sector	Addresses	Max Size
TestFlash (TF) (Reserved)	230000h to 231F7Fh	8064 bytes
OTP Area	231F80h to 231FFBh	124 bytes
Protection Registers (reserved)	231FFCh to 231FFFh	4 bytes
Flash 0 (F0)	000000h to 001FFFh	8 Kbytes
Flash 1 (F1)	002000h to 003FFFh	8 Kbytes
Flash 2 (F2)	004000h to 00FFFFh	48 Kbytes
Flash 3 (F3)	010000h to 01FFFFh	64 Kbytes
Hardware Emulated EEPROM sectors (reserved)	228000h to 22CFFFh	8 Kbytes
Emulated EEPROM	220000h to 2203FFh	1 Kbyte

FUNCTIONAL DESCRIPTION (Cont'd)

Table 9. Memory Structure for 256K Flash device

Sector	Addresses	Max Size
TestFlash (TF) (Reserved)	230000h to 231F7Fh	8064 bytes
OTP Area	231F80h to 231FFBh	124 bytes
Protection Registers (reserved)	231FFCh to 231FFFh	4 bytes
Flash 0 (F0)	000000h to 001FFFh	8 Kbytes
Flash 1 (F1)	002000h to 003FFFh	8 Kbytes
Flash 2 (F2)	004000h to 00FFFFh	48 Kbytes
Flash 3 (F3)	010000h to 01FFFFh	64 Kbytes
Flash 4 (F4)	020000h to 02FFFFh	64 Kbytes
Flash 5 (F5)	030000h to 03FFFFh	64 Kbytes
Hardware Emulated EEPROM sectors (reserved)	228000h to 22CFFFh	8 Kbytes
Emulated EEPROM	220000h to 2203FFh	1 Kbyte

FUNCTIONAL DESCRIPTION (Cont'd)

3.2.3 Operation

The memory has a register interface mapped in memory space (segment 22h). All operations are enabled through the FCR (Flash Control Register), ECR (E³™ Control Register).

All operations on the Flash must be executed from another memory (internal RAM, E³™, external memory).

Flash (including TestFlash) and E³™ are independent, this means that one can be read while the other is written. However simultaneous Flash and E³™ write operations are forbidden.

An interrupt can be generated at the end of a Flash or an E³™ write operation: this interrupt is multiplexed with an external interrupt EXTINTx (device dependent) to generate an interrupt INTx.

The status of a write operation inside the Flash and the E³™ memories can be monitored through the FESR[1:0] registers.

Control and Status registers are mapped in memory (segment 22h), as shown in the following figure.

Figure 32. Control and Status Register Map.

Register Interface	
224000h / 221000h	FCR
224001h / 221001h	ECR
224002h / 221002h	FESR0
224003h / 221003h	FESR1

In order to use the same data pointer register (DPR) to point both to the E³™ (220000h-2203FFh) and to these control and status registers, the Flash and E³™ control registers are mapped not only at page 0x89 (224000h-224003h) but also on page 0x88 (221000h-221003h).

If the RESET pin is activated during a write operation, the write operation is interrupted. In this case the user must repeat this last write operation following power on or reset. If the internal supply voltage drops below the V_{IT} threshold, a reset sequence is generated automatically by hardware.

3.2.4 E³™ Update Operation

The update of the E³™ content can be made by pages of 16 consecutive bytes. The Page Update operation allows up to 16 bytes to be loaded into the RAM buffer that replace the ones already contained in the specified address.

Each time a Page Update operation is executed in the E³™, the RAM buffer content is programmed in the next free block relative to the specified page (the RAM buffer is previously automatically filled with old data for all the page addresses not selected for updating). If all the 4 blocks of the specified page in the current E³™ sector are full, the page content is copied to the complementary sector, that becomes the new current one.

After that the specified page has been copied to the next free block, one erase phase is executed on the complementary sector, if the 4 erase phases have not yet been executed. When the selected page is copied to the complementary sector, the remaining 63 pages are also copied to the first block of the new sector; then the first erase phase is executed on the previous full sector. All this is executed in a hidden manner, and the End Page Update Interrupt is generated only after the end of the complete operation.

At Reset the two status pages are read in order to detect which is the sector that is currently mapping the E³™, and in which block each page is mapped. A system defined routine written in TestFlash is executed at reset, so that any previously aborted write operation is restarted and completed.

Figure 33. Hardware Emulation Flow

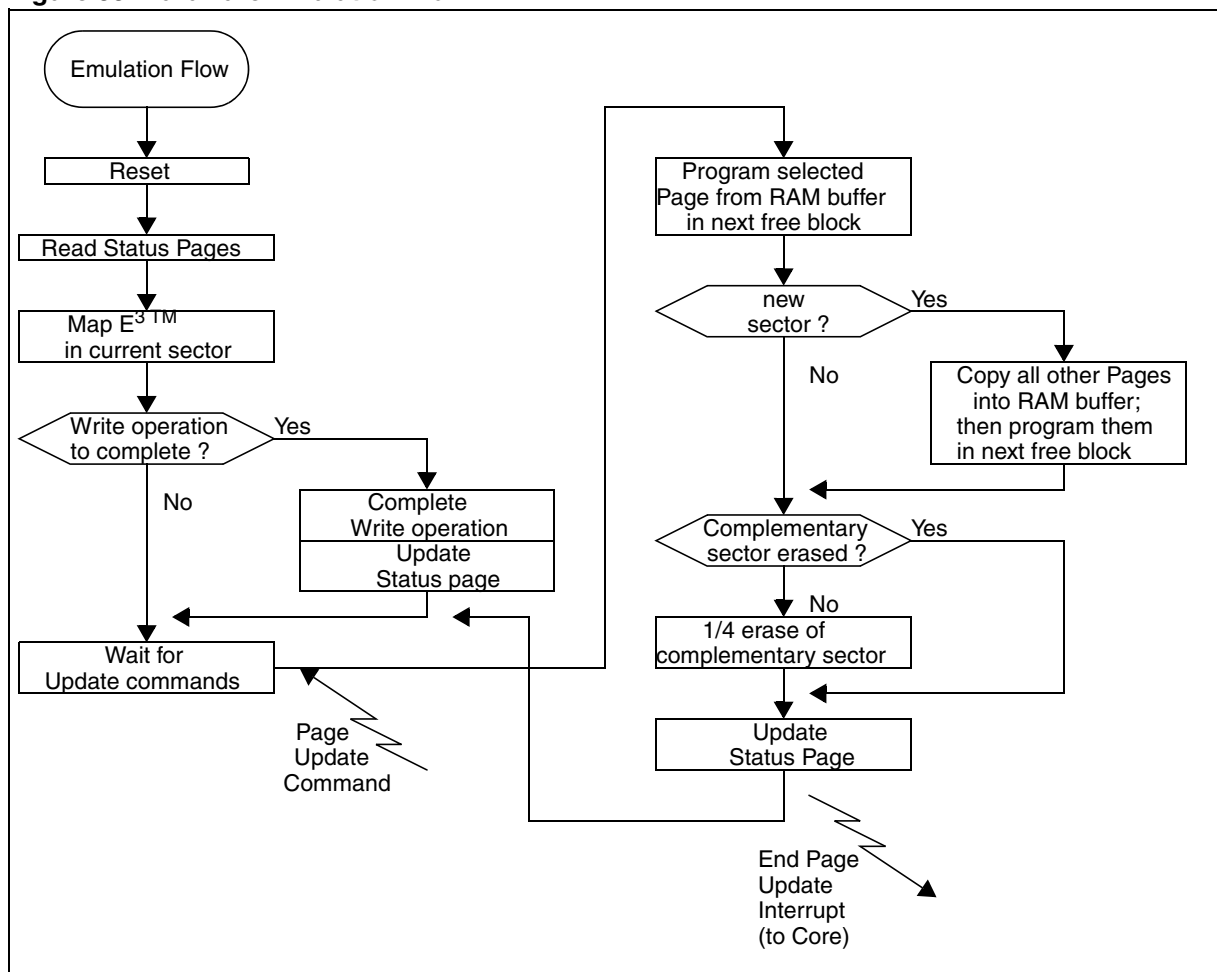

3.2.5 Important note on Flash Erase Suspend

Refer to [Section 13.1 on page 408](#);

3.3 REGISTER DESCRIPTION

3.3.1 Control Registers

FLASH CONTROL REGISTER (FCR)

Address: 224000h / 221000h- Read/Write

Reset value: 0000 0000 (00h)

7	6	5	4	3	2	1	0
FWMS	FPAGE	FCHIP	FBYTE	FSECT	FSUSP	PROT	FBUSY

The Flash Control Register is used to enable all the operations for the Flash and the TestFlash memories.

Bit 7 = **FWMS**: *Flash Write Mode Start (Read/Write)*.

This bit must be set to start each write/erase operation in Flash memory. At the end of the write/erase operation or during a Sector Erase Suspend this bit is automatically reset. To resume a suspended Sector Erase operation, this bit must be set again. Resetting this bit by software does not stop the current write operation.

0: No effect

1: Start Flash write

Bit 6 = **FPAGE**: *Flash Page program (Read/Write)*.

This bit must be set to select the Page Program operation in Flash memory. This bit is automatically reset at the end of the Page Program operation.

The Page Program operation allows to program “0”s in place of “1”s. From 1 to 16 bytes can be entered (in any order, no need for an ordered address sequence) before starting the execution by setting the FWMS bit. All the addresses must belong to the same page (only the 4 LSBs of address can change). Data to be programmed and addresses in which to program must be provided (through an LD instruction, for example). Data contained in page addresses that are not entered are left unchanged.

0: Deselect page program

1: Select page program

Bit 5 = **FCHIP**: *Flash CHIP erase (Read/Write)*.

This bit must be set to select the Chip Erase operation in Flash memory. This bit is automatically reset at the end of the Chip Erase operation.

The Chip Erase operation erases all the Flash locations to FFh. The operation is limited to Flash

code: sectors F0-F3 (or F0-F5 for the ST92F250), TestFlash and E3™ excluded. The execution starts by setting the FWMS bit. It is not necessary to pre-program the sectors to 00h, because this is done automatically.

0: Deselect chip erase

1: Select chip erase

Bit 4 = **FBYTE**: *Flash byte program (Read/Write)*.

This bit must be set to select the Byte Program operation in Flash memory. This bit is automatically reset at the end of the Byte Program operation.

The Byte Program operation allows “0”s to be programmed in place of “1”s. Data to be programmed and an address in which to program must be provided (through an LD instruction, for example) before starting execution by setting bit FWMS.

0: Deselect byte program

1: Select byte program

Bit 3 = **FSECT**: *Flash sector erase (Read/Write)*.

This bit must be set to select the Sector Erase operation in Flash memory. This bit is automatically reset at the end of the Sector Erase operation.

The Sector Erase operation erases all the Flash locations to FFh. From 1 to 6 sectors (F0-F5) can be simultaneously erased. These sectors can be entered before starting the execution by setting the FWMS bit. An address located in the sector to erase must be provided (through an LD instruction, for example), while the data to be provided is don’t care. It is not necessary to pre-program the sectors to 00h, because this is done automatically.

0: Deselect sector erase

1: Select sector erase

Bit 2 = **FSUSP**: *Flash sector erase suspend (Read/Write)*.

This bit must be set to suspend the current Sector Erase operation in Flash memory in order to read data to or from program data to a sector not being erased. The FSUSP bit must be reset (and FWMS must be set again) to resume a suspended Sector Erase operation.

The Erase Suspend operation resets the Flash memory to normal read mode (automatically resetting bit FBUSY) in a maximum time of 15µs.

REGISTER DESCRIPTION (Cont'd)

When in Erase Suspend the memory accepts only the following operations: Read, Erase Resume and Byte Program. Updating the E3™ memory is not possible during a Flash Erase Suspend.

- 0: Resume sector erase when FWMS is set again.
- 1: Suspend Sector erase

Bit 1 = PROT: Set Protection (Read/Write). This bit must be set to select the Set Protection operation. This bit is automatically reset at the end of the Set Protection operation.

The Set Protection operation allows “0”s in place of “1”s to be programmed in the four Non Volatile Protection registers. From 1 to 4 bytes can be entered (in any order, no need for an ordered address sequence) before starting the execution by setting the FWMS bit. Data to be programmed and addresses in which to program must be provided (through an LD instruction, for example). Protection contained in addresses that are not entered are left unchanged.

- 0: Deselect protection
- 1: Select protection

Bit 0 = FBUSY: Flash Busy (Read Only). This bit is automatically set during Page Program, Byte Program, Sector Erase or Set Protection operations when the first address to be modified is latched in Flash memory, or during Chip Erase operation when bit FWMS is set. When this bit is set every read access to the Flash memory will output invalid data (FFh equivalent to a NOP instruction), while every write access to the Flash memory will be ignored. At the end of the write operations or during a Sector Erase Suspend this bit is automatically reset and the memory returns to read mode. After an Erase Resume this bit is automatically set again. The FBUSY bit remains high for a maximum of 10µs after Power-Up and when exiting Power-Down mode, meaning that the Flash memory is not yet ready to be accessed.

- 0: Flash not busy
- 1: Flash busy

E3™ CONTROL REGISTER (ECR)

Address: 224001h /221001h- Read/Write
Reset value: 000x x000 (xxh)

7	6	5	4	3	2	1	0
EWMS	EPAGE	ECHIP			WFIS	FEIEN	EBUSY

The E3™ Control Register is used to enable all the operations for the E3™ memory.

The ECR also contains two bits (WFIS and FEIEN) that are related to both Flash and E3™ memories.

Bit 7 = EWMS: E3™ Write Mode Start. This bit must be set to start every write/erase operation in the E3™ memory. At the end of the write/erase operation this bit is automatically reset. Re-setting by software this bit does not stop the current write operation.

- 0: No effect
- 1: Start E3™ write

Bit 6 = EPAGE: E3™ page update. This bit must be set to select the Page Update operation in E3™ memory. The Page Update operation allows to write a new content: both “0”s in place of “1”s and “1”s in place of “0”s. From 1 to 16 bytes can be entered (in any order, no need for an ordered address sequence) before starting the execution by setting bit EWMS. All the addresses must belong to the same page (only the 4 LSBs of address can change). Data to be programmed and addresses in which to program must be provided (through an LD instruction, for example). Data contained in page addresses that are not entered are left unchanged. This bit is automatically reset at the end of the Page Update operation.

- 0: Deselect page update
- 1: Select page update

Bit 5 = ECHIP: E3™ chip erase. This bit must be set to select the Chip Erase operation in the E3™ memory. The Chip Erase operation allows to erase all the E3™ locations to FFh. The execution starts by setting bit EWMS. This bit is automatically reset at the end of the Chip Erase operation.

- 0: Deselect chip erase
- 1: Select chip erase

Bit 4:3 = Reserved.

REGISTER DESCRIPTION (Cont'd)

Bit 2 = **WFIS**: *Wait For Interrupt Status*.

If this bit is reset, the WFI instruction puts the Flash macrocell in Stand-by mode (immediate read possible, but higher consumption: 100 µA); if it is set, the WFI instruction puts the Flash macrocell in Power-Down mode (recovery time of 10µs needed before reading, but lower consumption: 10µA). The Stand-by mode or the Power-Down mode will be entered only at the end of any current Flash or E³™ write operation.

In the same way following an HALT or a STOP instruction, the Memory enters Power-Down mode only after the completion of any current write operation.

0: Flash in Stand-by mode on WFI

1: Flash in Power-Down mode on WFI

Note: HALT or STOP mode can be exited without problems, but the user should take care when exiting WFI Power Down mode. If WFIS is set, the user code must reset the XT_DIV16 bit in the R242 register (page 55) before executing the WFI instruction. When exiting WFI mode, this gives the Flash enough time to wake up before the interrupt vector fetch.

Bit 1 = **FEIEN**: *Flash & E³™ Interrupt enable*.

This bit selects the source of interrupt channel INTx between the external interrupt pin and the Flash/E³™ End of Write interrupt. Refer to the Interrupt chapter for the channel number.

0: External interrupt enabled

1: Flash & E³™ Interrupt enabled

Bit 0 = **EBUSY**: *E³™ Busy (Read Only)*.

This bit is automatically set during a Page Update operation when the first address to be modified is latched in the E³™ memory, or during Chip Erase operation when bit EWMS is set. At the end of the write operation or during a Sector Erase Suspend this bit is automatically reset and the memory returns to read mode. When this bit is set every read access to the E³™ memory will output invalid data (FFh equivalent to a NOP instruction), while every write access to the E³™ memory will be ignored. At the end of the write operation this bit is automatically reset and the memory returns to read mode. Bit EBUSY remains high for a maximum of 10ms after Power-Up and when exiting Power-Down mode, meaning that the E³™ memory is not yet ready to be accessed.

0: E³™ not busy

1: E³™ busy

3.3.2 Status Registers

Two Status Registers (FESR[1:0]) are available to check the status of the current write operation in Flash and E³™ memories.

During a Flash or an E³™ write operation any attempt to read the memory under modification will output invalid data (FFh equivalent to a NOP instruction). This means that the Flash memory is not fetchable when a write operation is active: the write operation commands must be given from another memory (E³™, internal RAM, or external memory).

FLASH & E³™ STATUS REGISTER 0 (FESR0)

Address: 224002h /221002h -Read/Write

Reset value: 0000 0000 (00h)

7	6	5	4	3	2	1	0
FEERR	FESS6	FESS5	FESS4	FESS3	FESS2	FESS1	FESS0

Bit 7 = **FEERR**: *Flash or E³™ write ERROR (Read/Write)*.

This bit is set by hardware when an error occurs during a Flash or an E³™ write operation. It must be cleared by software.

0: Write OK

1: Flash or E³™ write error

Bit 6:0 = **FESS[6:0]**. *Flash and E³™ Sectors Status Bits (Read Only)*.

These bits are set by hardware and give the status of the 7 Flash and E³™ sectors.

– FESS6 = TestFlash and OTP

– FESS5:4 = E³™ sectors

For 128K and 64K Flash devices:

– FESS3:0 = Flash sectors (F3:0)

For the ST92F250 (256K):

– FESS3 gives the status of F5, F4 and F3 sectors: the status of all these three sectors are ORed on this bit

– FESS2:0 = Flash sectors (F2:0)

REGISTER DESCRIPTION (Cont'd)

The meaning of the FESSx bit for sector x is given in [Table 10](#).

Table 10. Sector Status Bits

FEERR	FBUSY EBUSY	FSUSP	FESSx=1 meaning
1	-	-	Write Error in Sector x
0	1	-	Write operation on-going in sector x
0	0	1	Sector Erase Suspended in sector x
0	0	0	Don't care

FLASH & E³™ STATUS REGISTER 1 (FESR1)

Address: 224003h /221003h-Read Only

Reset value: 0000 0000 (00h)

7	6	5	4	3	2	1	0
ERER	PGER	SWER					

Bit 7 = **ERER**. *Erase error (Read Only)*.

This bit is set by hardware when an Erase error occurs during a Flash or an E³™ write operation. This error is due to a real failure of a Flash cell, that can no longer be erased. This kind of error is fatal and the sector where it occurred must be discarded. This bit is automatically cleared when bit FEERR of the FESR0 register is cleared by software.

0: Erase OK
1: Erase error

Bit 6 = **PGER**. *Program error (Read Only)*.

This bit is automatically set when a Program error occurs during a Flash or an E³™ write operation. This error is due to a real failure of a Flash cell, that can no longer be programmed. The byte where this error occurred must be discarded (if it was in the E³™ memory, the byte must be reprogrammed to FFh and then discarded, to avoid the error occurring again when that byte is internally moved). This bit is automatically cleared when bit FEERR of the FESR0 register is cleared by software.

0: Program OK
1: Flash or E³™ Programming error

Bit 5 = **SWER**. *Swap or 1 over 0 Error (Read Only)*.

This bit has two different meanings, depending on whether the current write operation is to Flash or E³™ memory.

In Flash memory this bit is automatically set when trying to program at 1 bits previously set at 0 (this does not happen when programming the Protection bits). This error is not due to a failure of the Flash cell, but only flags that the desired data has not been written.

In the E³™ memory this bit is automatically set when a Program error occurs during the swapping of the unselected pages to the new sector when the old sector is full (see AN1152 for more details).

This error is due to a real failure of a Flash cell, that can no longer be programmed. When this error is detected, the embedded algorithm automatically exits the Page Update operation at the end of the Swap phase, without performing the Erase Phase 0 on the full sector. In this way the old data are kept, and through predefined routines in Test-Flash (Find Wrong Pages = 230029h and Find Wrong Bytes = 23002Ch), the user can compare the old and the new data to find where the error occurred.

Once the error has been discovered the user must take to end the stopped Erase Phase 0 on the old sector (through another predefined routine in Test-Flash: Complete Swap = 23002Fh). The byte where the error occurred must be reprogrammed to FFh and then discarded, to avoid the error occurring again when that byte is internally moved.

This bit is automatically cleared when bit FEERR of the FESR0 register is cleared by software.

Bit 4:0 = Reserved.

3.4 WRITE OPERATION EXAMPLE

Each operation (both Flash and E³™) is activated by a sequence of instructions like the following:

```
OR   FCR, #OPMASK ;Operation selection
LD   ADD1, #DATA1 ;1st Add and Data
LD   ADD2, #DATA2 ;2nd Add and Data
..   ....., .....
LD   ADDn, #DATAn ;nth Add and Data
      ;n range = (1 to 16)
OR   FCR, #80h    ;Operation start
```

The first instruction is used to select the desired operation by setting its corresponding selection bit in the Control Register (FCR for Flash operations, ECR for E³™ operations).

The load instructions are used to set the addresses (in the Flash or in the E³™ memory space) and the data to be modified.

The last instruction is used to start the write operation, by setting the start bit (FWMS for Flash operations, EWMS for E³™ operation) in the Control register.

Once selected, but not yet started, one operation can be cancelled by resetting the operation selection bit. Any latched address and data will be reset.

Warning: during the Flash Page Program or the E³™ Page Update operation it is forbidden to change the page address: only the last page address is effectively kept and all programming will effect only that page.

A summary of the available Flash and E³™ write operations are shown in the following tables:

Table 11. Flash Write Operations

Operation	Selection bit	Addresses and Data	Start bit	Typical Duration
Byte Program	FBYTE	1 byte	FWMS	10 μs
Page Program	FPAGE	From 1 to 16 bytes	FWMS	160 μs (16 bytes)
Sector Erase	FSECT	From 1 to 4 sectors	FWMS	1.5 s (1 sector)
Sector Erase Suspend	FSUSP	None	None	15 μs
Chip Erase	FCHIP	None	FWMS	3 s
Set Protection	PROT	From 1 to 4 bytes	FWMS	40 μs (4 bytes)

Table 12. E³™ Write Operations

Operation	Selection bit	Addresses and Data	Start bit	Typical Duration
Page Update	EPAGE	From 1 to 16 bytes	EWMS	30 ms
Chip Erase	ECHIP	None	EWMS	

3.5 PROTECTION STRATEGY

The protection bits are stored in the 4 locations from 231FFCh to 231FFFh (see Figure 34).

All the available protections are forced active during reset, then in the initialisation phase they are read from the TestFlash.

The protections are stored in 2 Non Volatile Registers. Other 2 Non Volatile Registers can be used as a password to re-enable test modes once they have been disabled.

The protections can be programmed using the Set Protection operation (see Control Registers paragraph), that can be executed from all the internal or external memories except the Flash or TestFlash itself.

The TestFlash area (230000h to 231F7Fh) is always protected against write access.

Figure 34. Protection Register Map

231FFCh	NVAPR
231FFDh	NVWPR
231FFEh	NVPWD0
231FFFh	NVPWD1

3.5.1 Non Volatile Registers

The 4 Non Volatile Registers used to store the protection bits for the different protection features are one time programmable by the user.

Access to these registers is controlled by the protections related to the TestFlash. Since the code to program the Protection Registers cannot be fetched by the Flash or the TestFlash memories, this means that, once the APRO or APBR bits in the NVAPR register are programmed, it is no longer possible to modify any of the protection bits. For this reason the NV Password, if needed, must be set with the same Set Protection operation used to program these bits. For the same reason it is strongly advised to never program the WPBR bit in the NVWPR register, as this will prevent any further write access to the TestFlash, and consequently to the Protection Registers.

NON VOLATILE ACCESS PROTECTION REGISTER (NVAPR)

Address: 231FFCh - Read/Write

Delivery value: 1111 1111 (FFh)

7	6	5	4	3	2	1	0
1	APRO	APBR	APEE	APEX	PWT2	PWT1	PWT0

Bit 7 = Reserved.

Bit 6 = **APRO**: FLASH access protection.

This bit, if programmed at 0, disables any access (read/write) to operands mapped inside the Flash address space (E³™ excluded), unless the current instruction is fetched from the TestFlash or from the Flash itself.

0: ROM protection on
1: ROM protection off

Bit 5 = **APBR**: TestFlash access protection.

This bit, if programmed at 0, disables any access (read/write) to operands mapped inside the TestFlash, the OTP and the protection registers, unless the current instruction is fetched from the TestFlash or the OTP area.

0: TestFlash protection on
1: TestFlash protection off

Bit 4 = **APEE**: E³™ access protection.

This bit, if programmed at 0, disables any access (read/write) to operands mapped inside the E³™ address space, unless the current instruction is fetched from the TestFlash or from the Flash, or from the E³™ itself.

0: E³™ protection on
1: E³™ protection off

Bit 3 = **APEX**: Access Protection from External memory.

This bit, if programmed at 0, disables any access (read/write) to operands mapped inside the address space of one of the internal memories (TestFlash, Flash, E³™, RAM), if the current instruction is fetched from an external memory.

0: Protection from external memory on
1: Protection from external memory off

PROTECTION STRATEGY (Cont'd)

Bit 2:0 = **PWT[2:0]**: *Password Attempt 2-0*.

If the TMDIS bit in the NVWPR register (231FFDh) is programmed to 0, every time a Set Protection operation is executed with Program Addresses equal to NVPWD1-0 (231FFE-Fh), the two provided Program Data are compared with the NVPWD1-0 content; if there is not a match one of PWT2-0 bits is automatically programmed to 0: when these three bits are all programmed to 0 the test modes are disabled forever. In order to intentionally disable test modes forever, it is sufficient to set a random Password and then to make 3 wrong attempts to enter it.

NON VOLATILE WRITE PROTECTION REGISTER (NVWPR)

Address: 231FFDh - Read/Write

Delivery value: 1111 1111 (FFh)

7	6	5	4	3	2	1	0
TMDIS	PWOK	WPBR	WPEE	WPRS3	WPRS2	WPRS1	WPRS0

Bit 7 = **TMDIS**: *Test mode disable (Read Only)*. This bit, if set to 1, allows to bypass all the protections in test and EPB modes. If programmed to 0, on the contrary, all the protections remain active also in test mode. The only way to enable the test modes if this bit is programmed to 0, is to execute the Set Protection operation with Program Addresses equal to NVPWD1-0 (231FFF-Eh) and Program Data matching with the content of NVPWD1-0. This bit is read only: it is automatically programmed to 0 when NVPWD1-0 are written for the first time.
 0: Test mode disabled
 1: Test mode enabled

Bit 6 = **PWOK**: *Password OK (Read Only)*. If the TMDIS bit is programmed to 0, when the Set Protection operation is executed with Program Addresses equal to NVPWD[1:0] and Program Data matching with NVPWD[1:0] content, the PWOK bit is automatically programmed to 0. When this bit is programmed to 0 TMDIS protection is bypassed and the test and EPB modes are enabled.
 0: Password OK
 1: Password not OK

Bit 5 = **WPBR**: *TestFlash Write Protection*. This bit, if programmed at 0, disables any write access to the TestFlash, the OTP and the protection registers. This protection cannot be temporarily disabled.
 0: TestFlash write protection on
 1: TestFlash write protection off
Note: it is strongly advised to never program the WPBR bit in the NVWPR register, as this will prevent any further write access to the protection registers.

Bit 4 = **WPEE**: *E³™ Write Protection*. This bit, if programmed to 0, disables any write access to the E³™ address space. This protection can be temporary disabled by executing the Set Protection operation and writing 1 into this bit. To restore the protection, reset the micro or execute another Set Protection operation on this bit.
 0: E³™ write protection on
 1: E³™ write protection off
Note: a read access to the NVWPR register restores any protection previously enabled.

Bit 3 = **WPRS3**: *FLASH Sectors 5-3 Write Protection*. This bit, if programmed to 0, disables any write access to the Flash sector 3 (and sectors 4 and 5 when available) address space(s). This protection can be temporary disabled by executing the Set Protection operation and writing 1 into this bit. To restore the protection, reset the micro or execute another Set Protection operation on this bit.
 0: FLASH Sectors 5-3 write protection on
 1: FLASH Sectors 5-3 write protection off
Note: a read access to the NVWPR register restores any protection previously enabled.

Bit 2:0 = **WPRS[2:0]**: *FLASH Sectors 2-0 Write Protection*. These bits, if programmed to 0, disable any write access to the 3 Flash sectors address spaces. These protections can be temporary disabled by executing the Set Protection operation and writing 1 into these bits. To restore the protection, reset the micro or execute another Set Protection operation on this bit.
 0: FLASH Sectors 2-0 write protection on
 1: FLASH Sectors 2-0 write protection off
Note: a read access to the NVWPR register restores any protection previously enabled.

PROTECTION STRATEGY (Cont'd)

NON VOLATILE PASSWORD (NVPWD1-0)

Address: 231FFF-231FFEh - Write Only

Delivery value: 1111 1111 (FFh)

7	6	5	4	3	2	1	0
PWD7	PWD6	PWD5	PWD4	PWD3	PWD2	PWD1	PWD0

Bit 7:0 = **PWD[7:0]**: Password bits 7:0 (Write Only).

These bits must be programmed with the Non Volatile Password that must be provided with the Set Protection operation to disable (first write access) or to reenable (second write access) the test and EPB modes. The first write access fixes the password value and resets the TMDIS bit of NVWPR (231FFDh). The second write access, with Program Data matching with NVPWD[1:0] content, resets the PWOK bit of NVWPR.

These two registers can be accessed only in write mode (a read access returns FFh).

3.5.2 Temporary Unprotection

On user request the memory can be configured so as to allow the temporary unprotection also of all access protections bits of NVAPR (write protection bits of NVWPR are always temporarily unprotectable).

Bit APEX can be temporarily disabled by executing the Set Protection operation and writing 1 into this bit, but only if this write instruction is executed from an internal memory (Flash and Test Flash excluded).

Bit APEE can be temporarily disabled by executing the Set Protection operation and writing 1 into this bit, but only if this write instruction is executed from the memory itself to unprotect (E³™).

Bits APRO and APBR can be temporarily disabled through a direct write at NVAPR location, by overwriting at 1 these bits, but only if this write instruction is executed from the memory itself to unprotect.

To restore the access protections, reset the micro or execute another Set Protection operation by writing 0 to the desired bits.

Note: To restore all the protections previously enabled in the NVAPR or NVWPR register, read the corresponding register.

When an internal memory (Flash, TestFlash or E³™) is protected in access, also the data access through a DMA of a peripheral is forbidden (it returns FFh). To read data in DMA mode from a protected memory, first it is necessary to temporarily unprotect that memory.

The temporary unprotection allows also to update a protected code.

Refer to the following figures to manage the Test/EPB, Access and Write protection modes.

Figure 35. Test /EPB Mode Protection

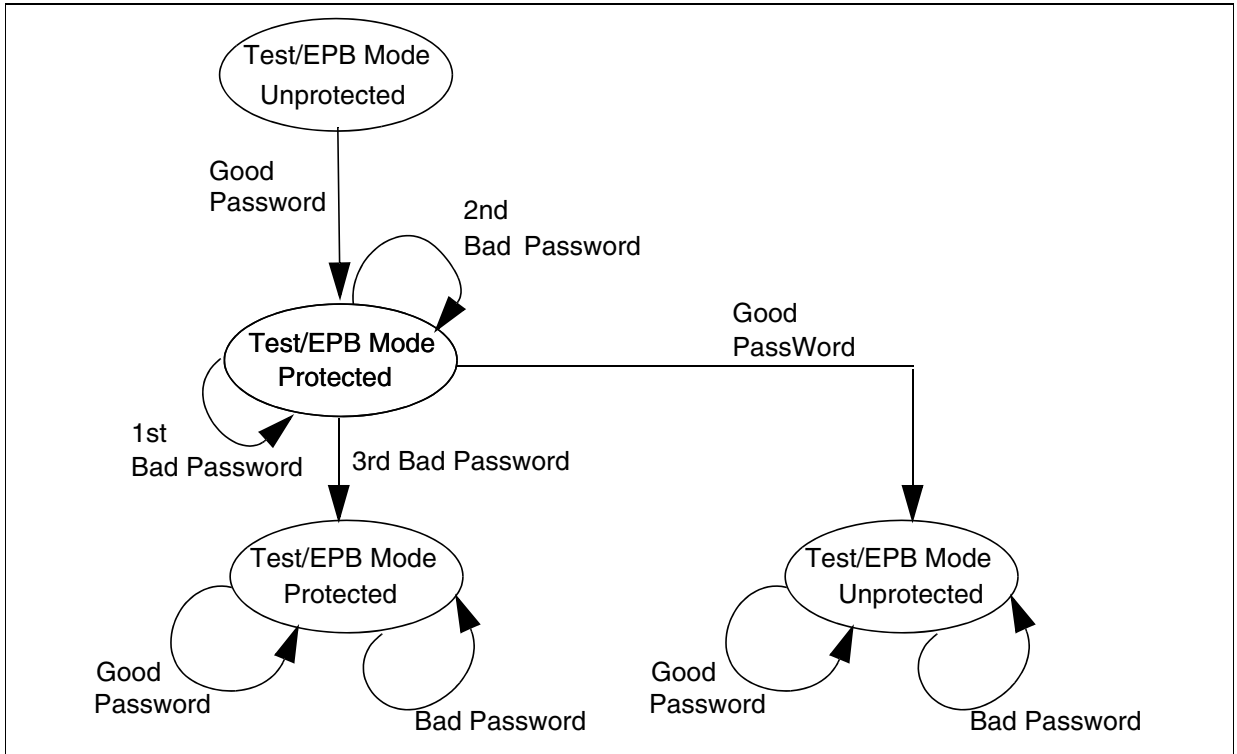

Figure 36. Access Mode Protection

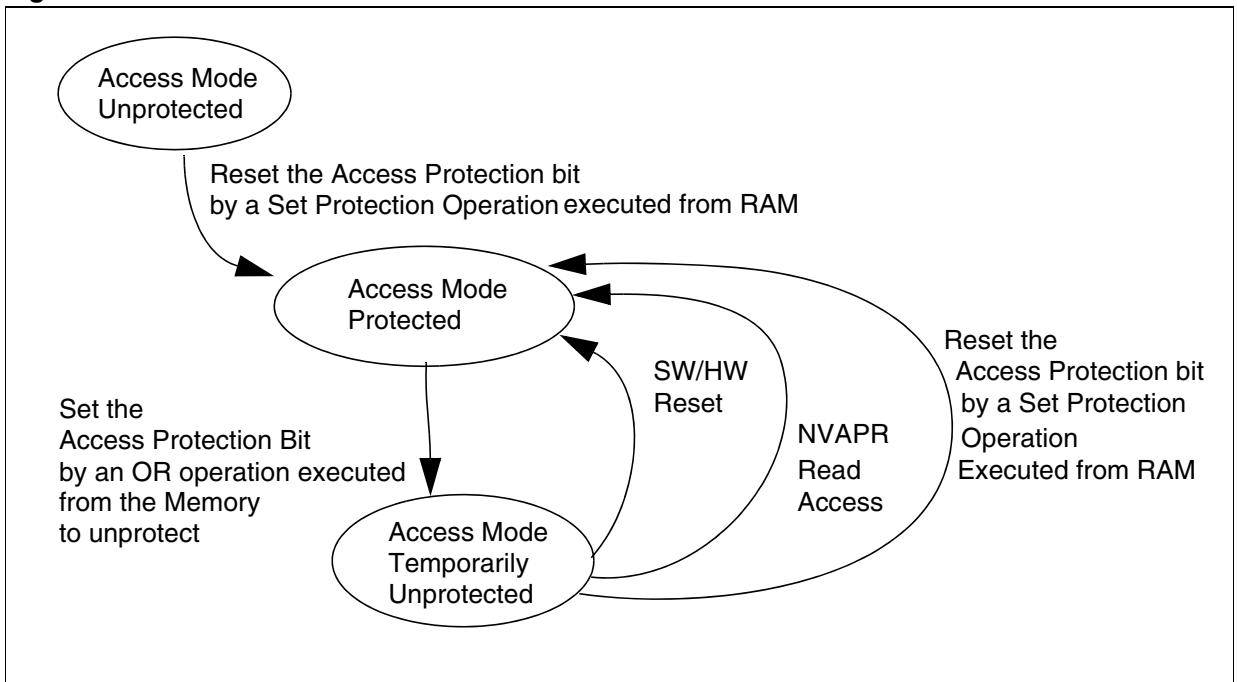
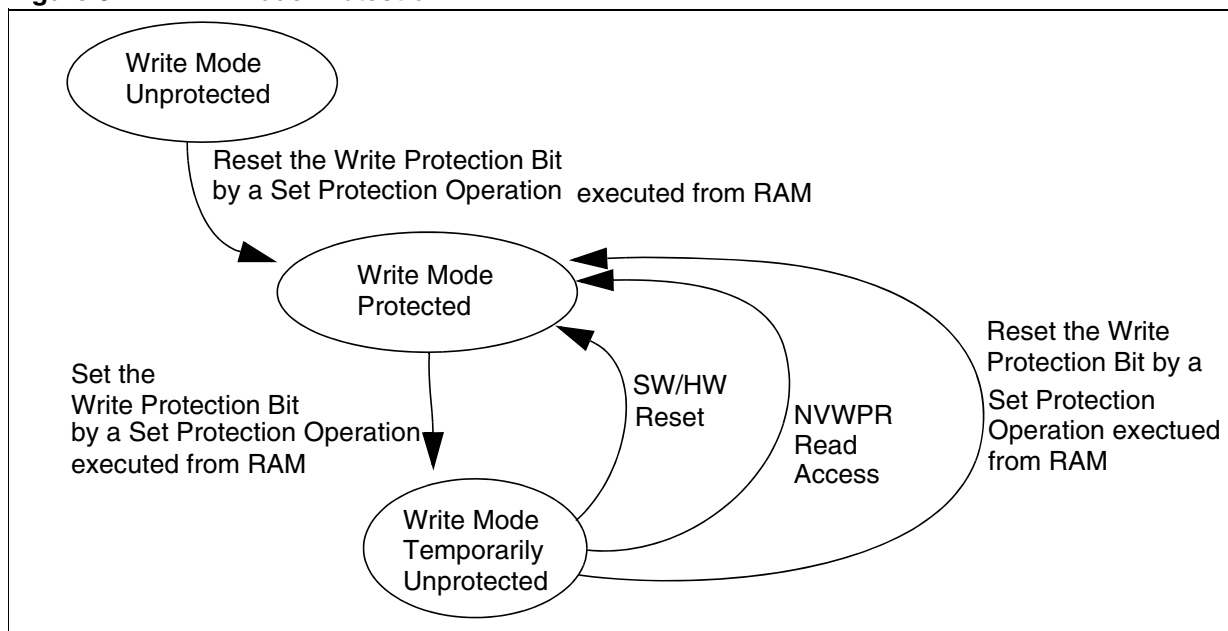

Figure 37. WRITE Mode Protection



3.6 FLASH IN-SYSTEM PROGRAMMING

The Flash memory can be programmed in-system through a serial interface (SCI0).

Exiting from reset, the ST9 executes the initialization from the TestFlash code (written in TestFlash), where it checks the value of the SOUT0 pin. If it is at 0, this means that the user wishes to update the Flash code, otherwise normal execution continues. In this second case, the TestFlash code reads the Reset vector.

If the Flash is virgin (read content is always FFh), the reset vector contains FFFFh. This will represent the last location of segment 0h, and it is interpreted by the TestFlash code as a flag indicating that the Flash memory is virgin and needs to be programmed. If the value 1 is detected on the SOUT0 pin and the Flash is virgin, a HALT instruction is executed, waiting for a hardware Reset.

3.6.1 Code Update Routine

The TestFlash Code Update routine is called automatically if the SOUT0 pin is held low during power-on.

The Code Update routine performs the following operations:

- Enables the SCI0 peripheral in synchronous mode
- Transmits a synchronization datum (25h);
- Waits for an address match (23h) with a timeout of 10ms (@ f_{OSC} 4 MHz);
- If the match is not received before the timeout, the execution returns to the Power-On routine;
- If the match is received, the SCI0 transmits a new datum (21h) to tell the external device that it is ready to receive the data to be loaded in RAM (that represents the code of the in-system programming routine);
- Receives two data representing the number of bytes to be loaded (max. 4 Kbytes);
- Receives the specified number of bytes (each one preceded by the transmission of a Ready to Receive character: (21h) and writes them in internal RAM starting from address 200010h.

The first 4 words should be the interrupt vectors of the 4 possible SCI interrupts, to be used by the in-system programming routine;

- Transmits a last datum (21h) as a request for end of communications;
- Receives the end of communication confirmation datum (any byte other than 25h);
- Resets all the unused RAM locations to FFh;
- Calls address 200018h in internal RAM;
- After completion of the in-system programming routine, an HALT instruction is executed and an Hardware Reset is needed.

The Code Update routine initializes the SCI0 peripheral as shown in the following table:

Table 13. SCI0 Registers (page 24) initialization

Register	Value	Notes
IVR - R244	10h	Vector Table in 0010h
ACR - R245	23h	Address Match is 23h
IDPR - R249	00h	SCI interrupt priority is 0
CHCR - R250	83h	8 Data Bits
CCR - R251	E8h	rec. clock: ext RXCLK0 trx clock: int CLKOUT0
BRGHR - R252	00h	
BRGLR - R253	04h	Baud Rate Divider is 4
SICR - R254	83h	Synchronous Mode
SOCCR - R255	01h	

In addition, the Code Update routine remaps the interrupts in the TestFlash (ISR = 23h), and configures I/O Ports P5.3 (SOUT0) and and P5.4 (CLKOUT0) as Alternate Functions.

Note: Four interrupt routines are used by the code update routine: SCI Receiver Error Interrupt routine (vector in 0010h), SCI address Match Interrupt routine (vector in 0012h), SCI Receiver Data Ready Interrupt routine (vector in 0014h) and SCI Transmitter Buffer Empty Interrupt routine (vector in 0016h).

Figure 38. Flash in-system Programming.

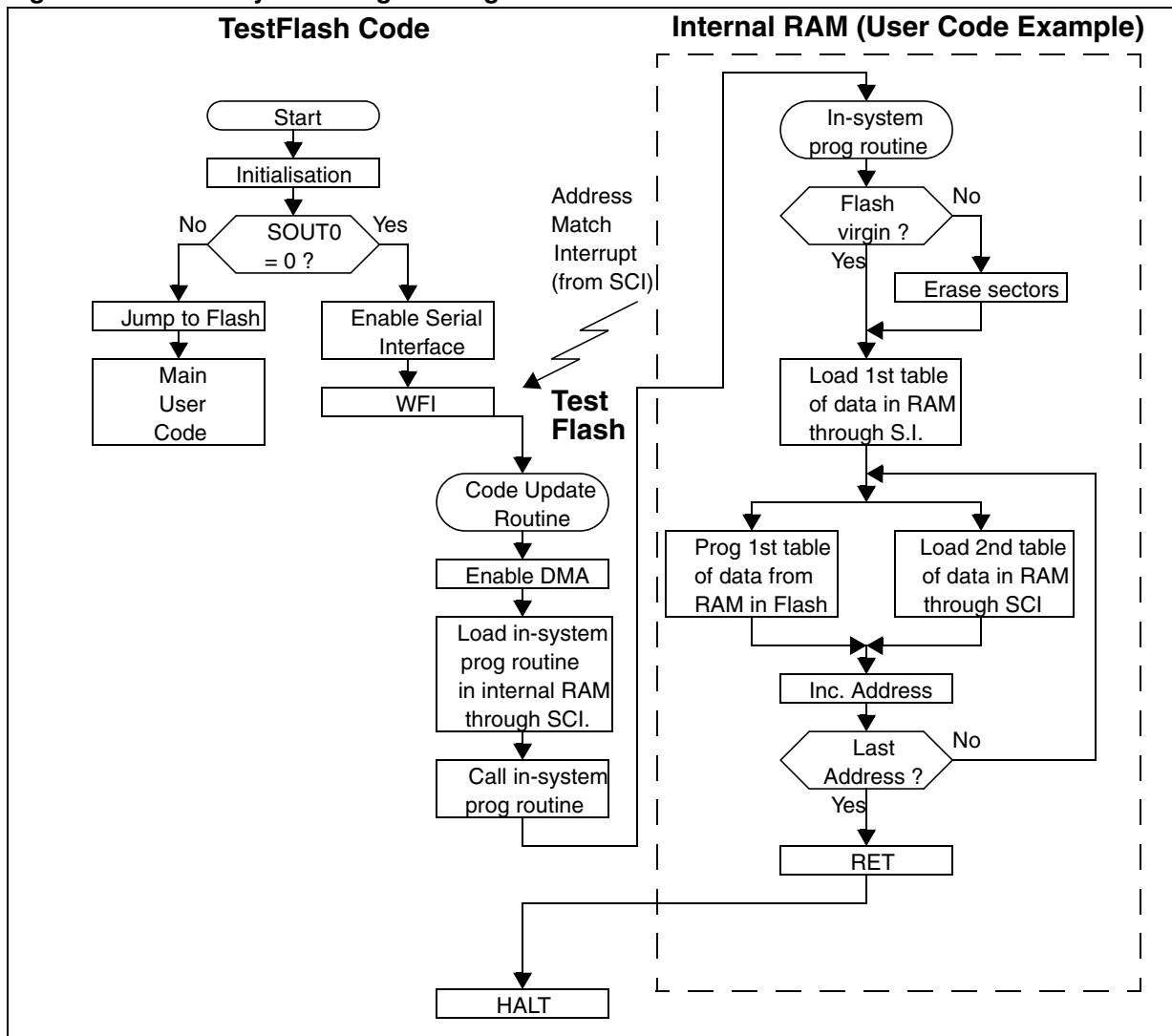

4 REGISTER AND MEMORY MAP

4.1 INTRODUCTION

The ST92F124/F150/F250 register map, memory map and peripheral options are documented in this section. Use this reference information to supplement the functional descriptions given elsewhere in this document.

4.2 MEMORY CONFIGURATION

The Program memory space of the ST92F124/F150/F250 up to 256K bytes of directly addressable on-chip memory, is fully available to the user.

4.2.1 Reset Vector Location

The user power on reset vector must be stored in the first two physical bytes of memory, 000000h and 000001h.

4.2.2 Location of Vector for External Watchdog Refresh

If an external watchdog is used, it must be refreshed during TestFlash execution by a user written routine. This routine has to be located in Flash memory, the address where the routine starts has to be written in 000006h (one word) while the seg-

ment where the routine is located has to be written in 000009h (one byte).

This routine is called at least once every time that the TestFlash executes an E³™ write operation. If the write operation has a long duration, the user routine is called with a rate fixed by location 000008h with an internal clock frequency of 2 MHz, location 000008h fixes the number of milliseconds to wait between two calls of the user routine.

Table 14. User Routine Parameters

Location	Size	Description
000006h to 000007h	2 bytes	User routine address
000008h	1 byte	ms rate at 2 MHz.
000009h	1 byte	User routine segment

If location 000006h to 000007h is virgin (FFFFh), the user routine is not called.

Figure 39. ST92F150/F250 External Memory Map

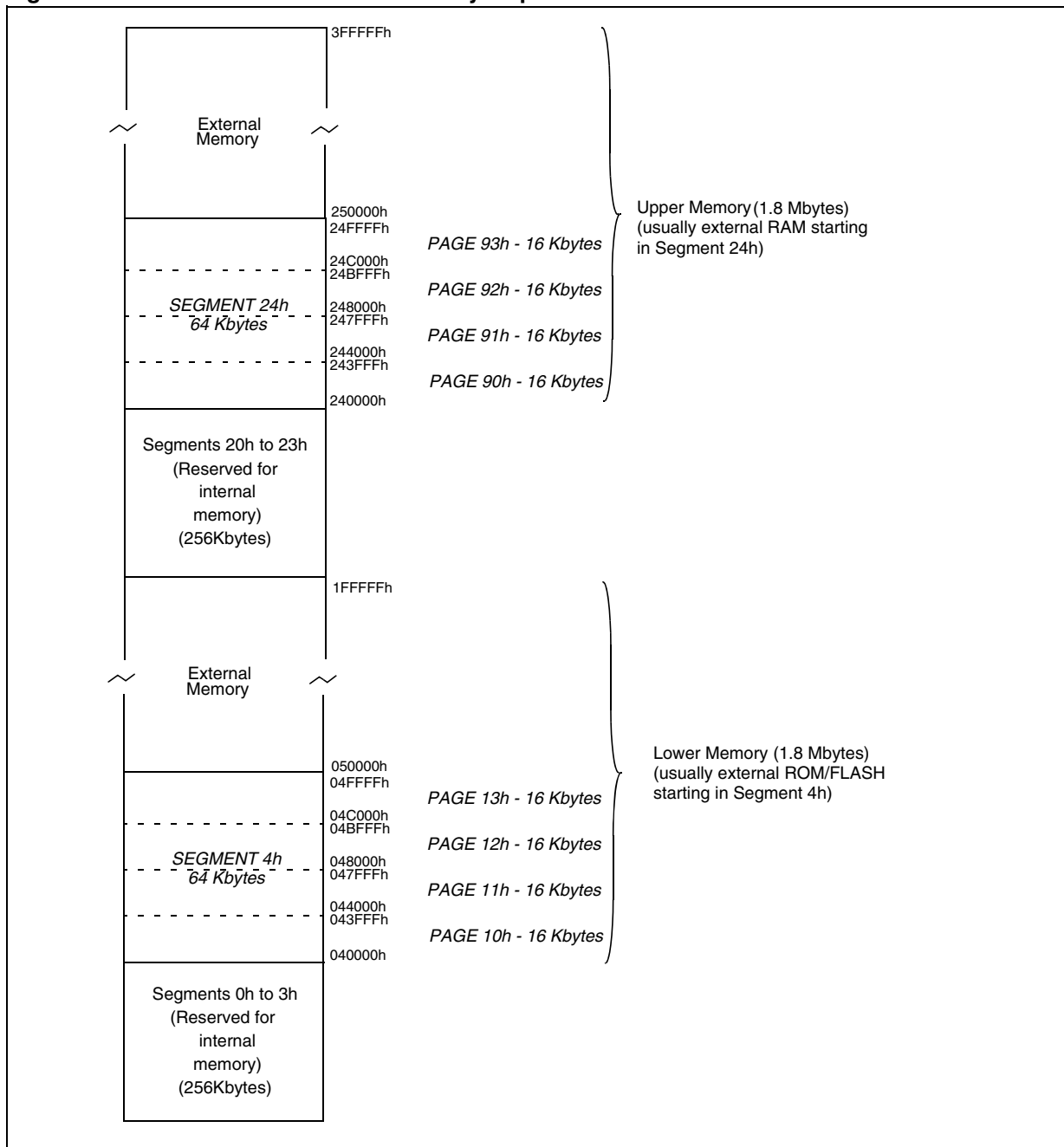

Figure 40. ST92F124/F150/F250 TESTFLASH and E³™ Memory Map

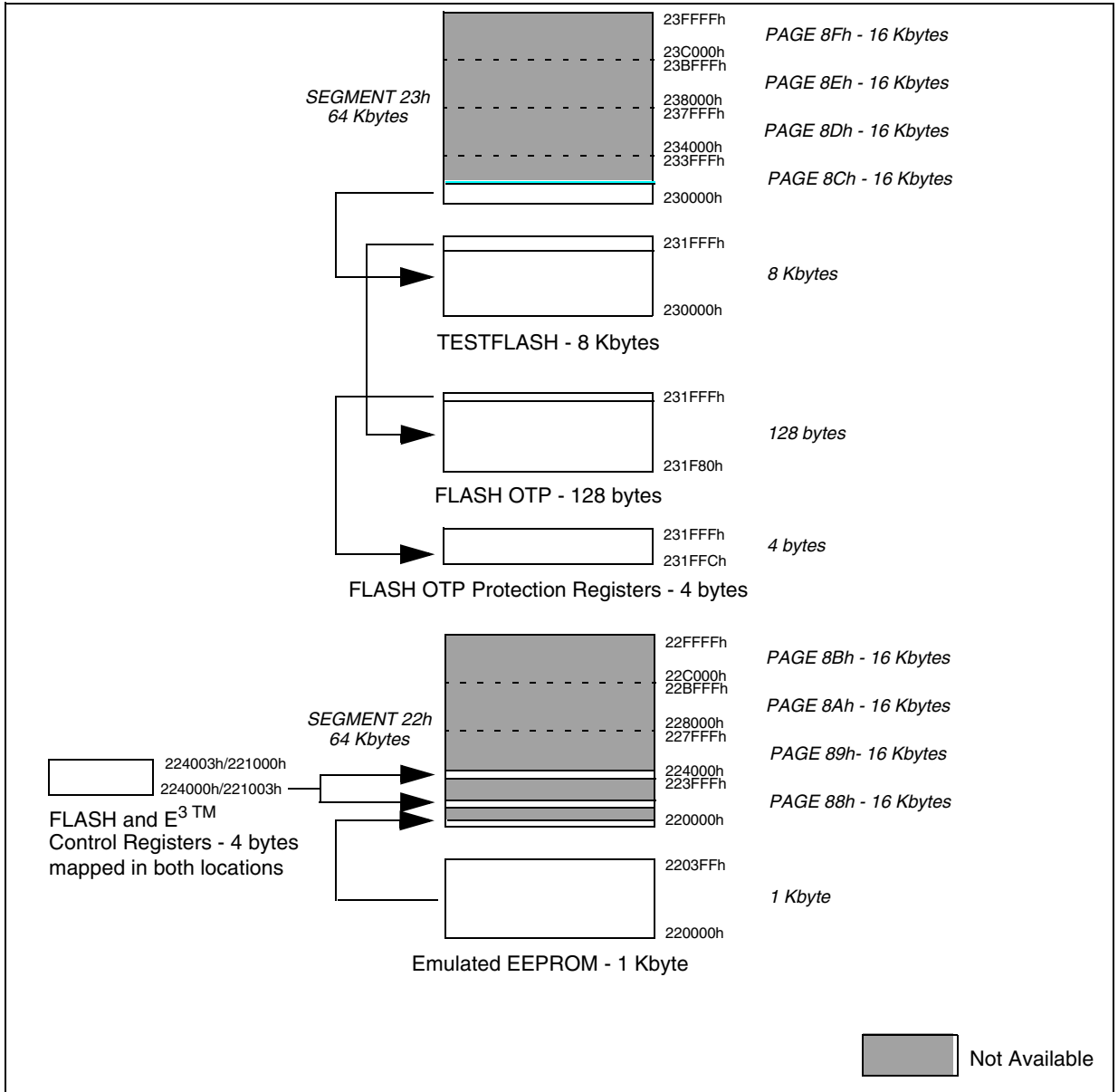

Figure 41. ST92F124/F150 Internal Memory Map (64K versions)

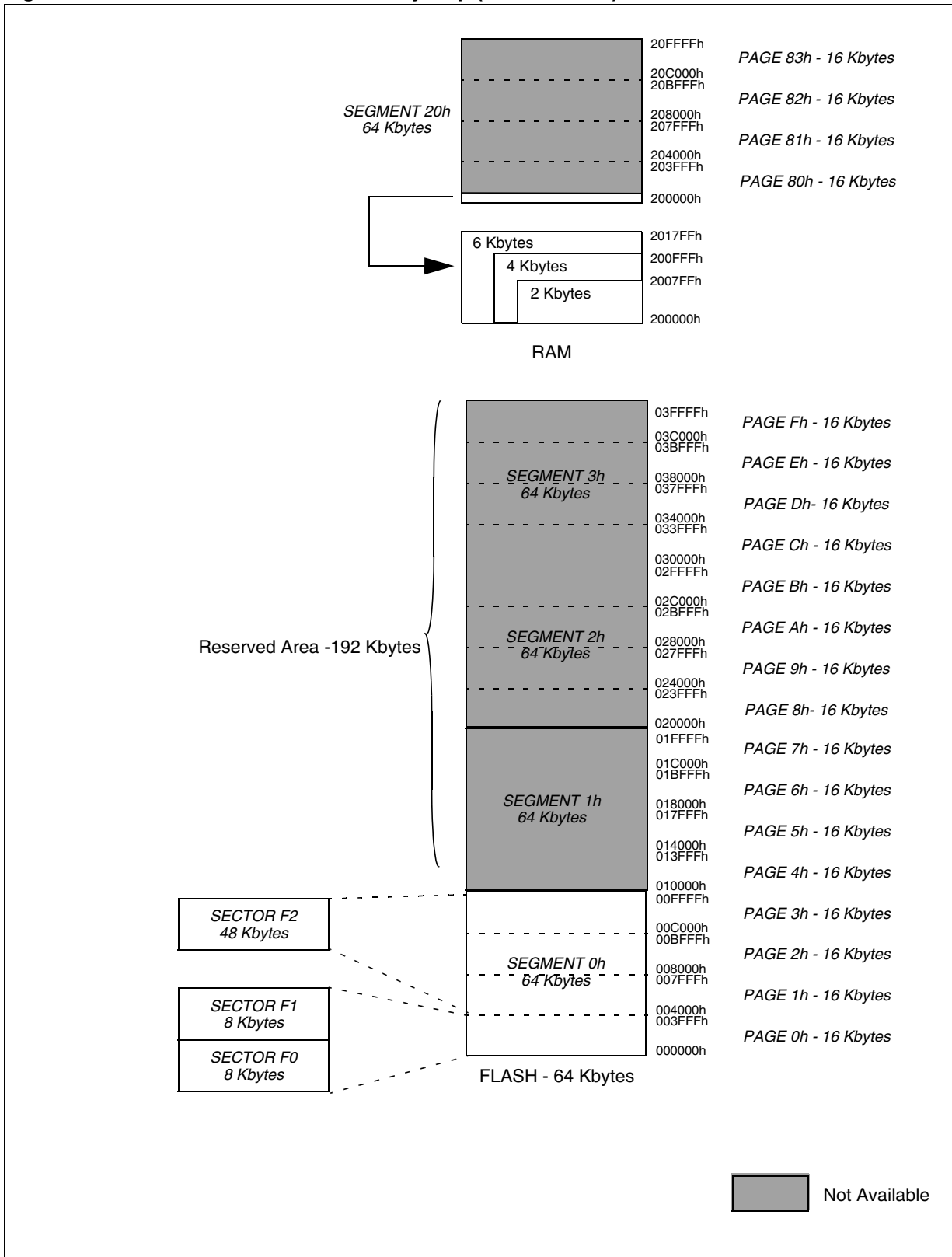

Figure 42. ST92F124/F150 Internal Memory Map (128K versions)

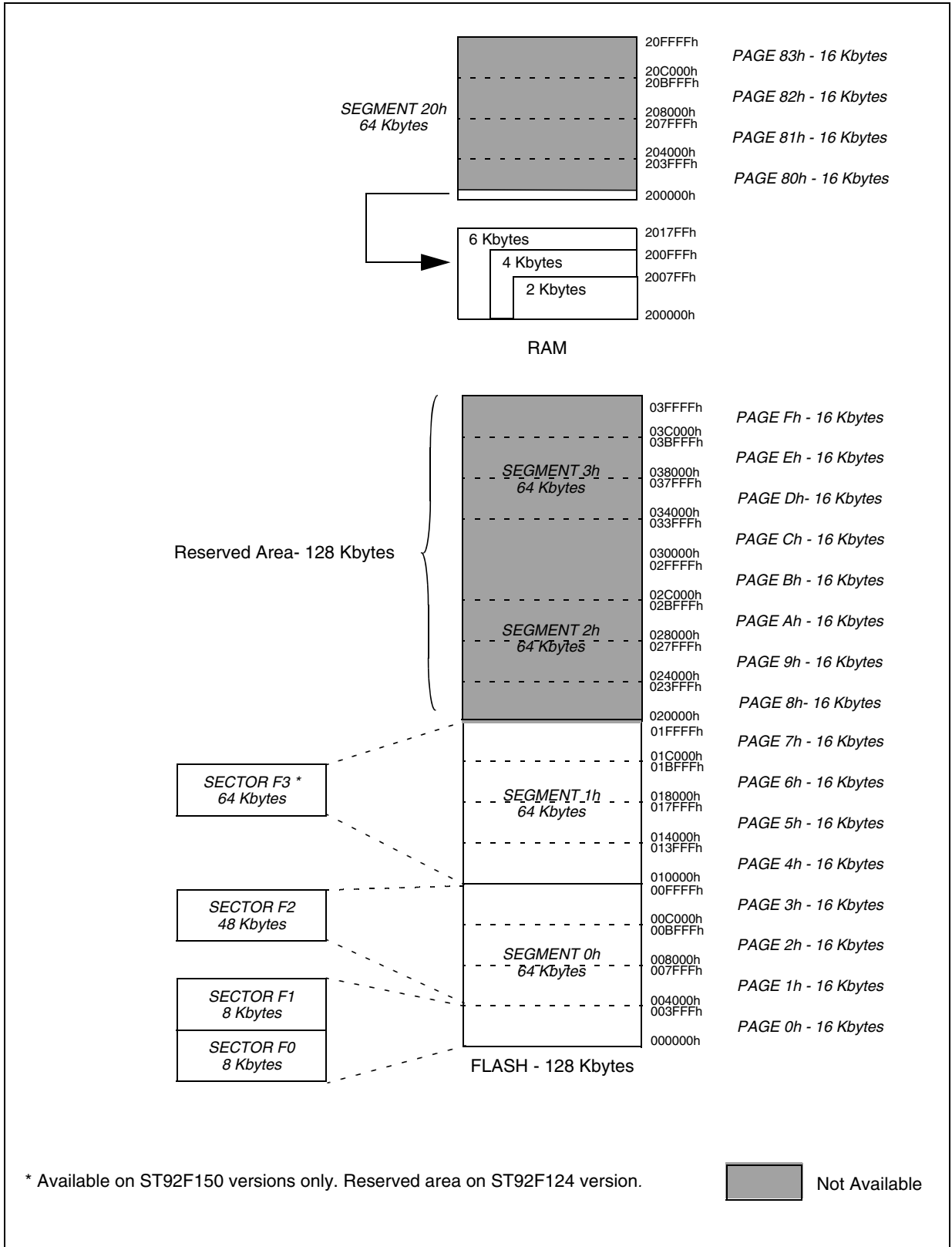
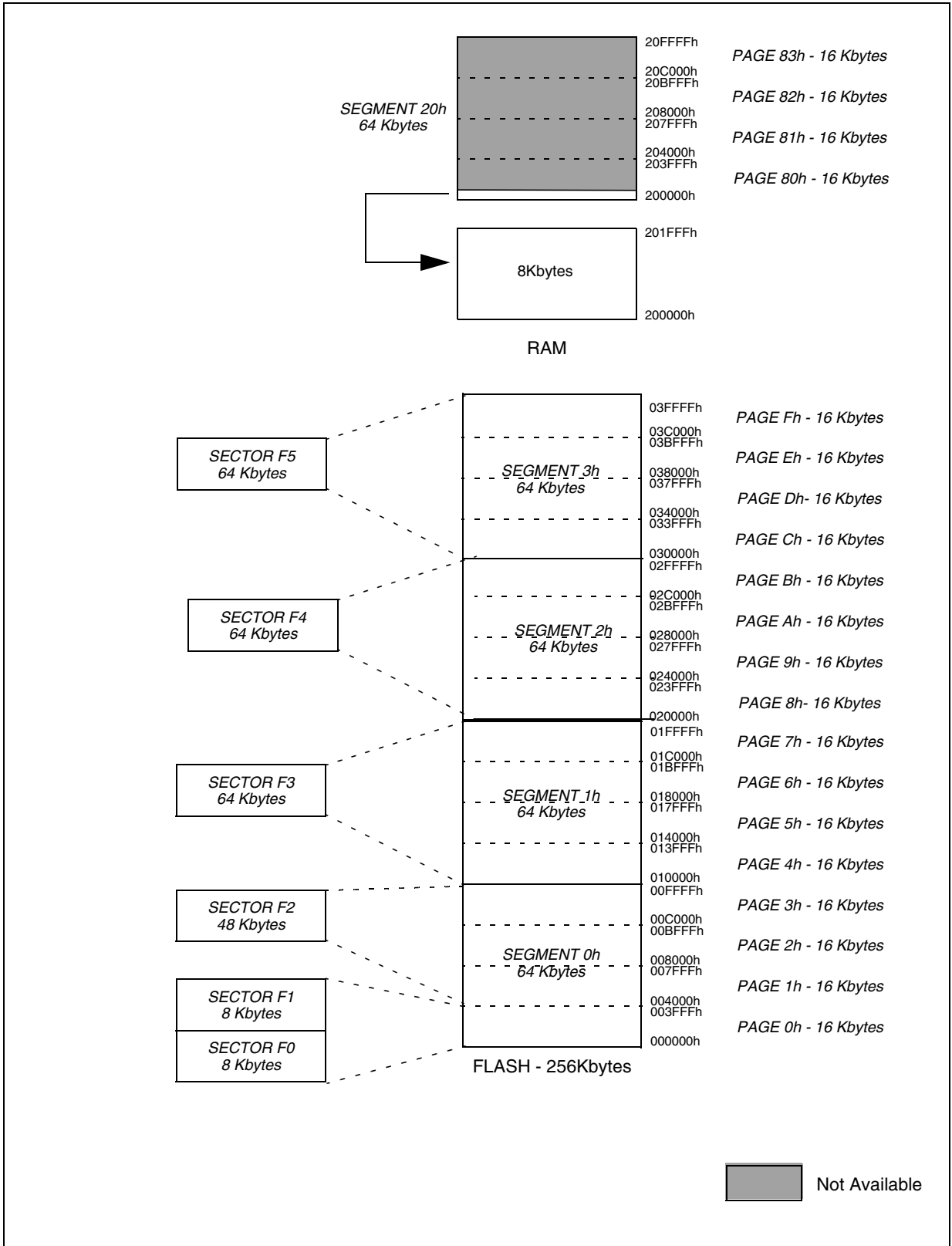

Figure 43. ST92F250 Internal Memory Map (256K version)



4.3 ST92F124/F150/F250 REGISTER MAP

Table 16 contains the map of the group F peripheral pages.

The common registers used by each peripheral are listed in Table 15.

Be very careful to correctly program both:

- The set of registers dedicated to a particular function or peripheral.

- Registers common to other functions.

- In particular, double-check that any registers with “undefined” reset values have been correctly initialized.

Warning: Note that in the **EIVR** and each **IVR** register, all bits are significant. Take care when defining base vector addresses that entries in the Interrupt Vector table do not overlap.

Table 15. Common Registers

Function or Peripheral	Common Registers
SCI, MFT	CICR + NICR + DMA REGISTERS + I/O PORT REGISTERS
ADC	CICR + NICR + I/O PORT REGISTERS
SPI, WDT, STIM	CICR + NICR + EXTERNAL INTERRUPT REGISTERS + I/O PORT REGISTERS
I/O PORTS	I/O PORT REGISTERS + MODER
EXTERNAL INTERRUPT	INTERRUPT REGISTERS + I/O PORT REGISTERS
RCCU	INTERRUPT REGISTERS + MODER

Table 16. Group F Pages Register Map

Resources available on the ST92F124/F150/F250 devices:

Reg.	Page																						
	0	2	3	7	8	9	10	11	20	21	22	23	24	26	28	29	36	37	38	39	40		
R255	Res.	Res	Port 7	Res.	MFT1	Res.	MFT0	Res.	I2C_0	MMU	I2C_1 *	JBLPD *	SCI-M	SCI-A *	EFT0 *	EFT1 *	CAN_1*	CAN_1*	CAN_1*	CAN_1*	CAN_1*	CAN_1*	
R254		Port 3																					
R253		Port 3																					
R252	WCR	Port 2	Port 6																				
R251	Res.																						
R250	WDT																						
R249		Port 2																					
R248		Port 2																					
R247	INT	Res.	Res.																				
R246		Port 1	Port 5																				
R245				MFT1																			
R244					MFT0																		
R243		Res.	Res.																				
R242		Port 0	Port 4	SPI																			
R241					MFT0																		
R240	STIM																						

Reg.	Page																	
	41	42	43	48	49	50	51	52	53	54	55	57	60	61	62	63		
R255	CAN_1*	CAN_1*	Port 9*	CAN_0*	CAN_0*	CAN_0*	CAN_0*	CAN_0*	CAN_0*	CAN_0*	CAN_0*	RCCU	Res.	WUJMU	STANDARD INTERRUPT CHANNELS	AD10	AD10	AD10
R254																		
R253																		
R252																		
R251																		
R250																		
R249																		
R248																		
R247																		
R246																		
R245																		
R244																		
R243																		
R242																		
R241																		
R240																		

* Available on some devices only

Table 17. Detailed Register Map

Page (Dec)	Block	Reg. No.	Register Name	Description	Reset Value Hex.	Doc. Page
N/A	Core	R230	CICR	Central Interrupt Control Register	87	34
		R231	FLAGR	Flag Register	00	35
		R232	RP0	Pointer 0 Register	xx	37
		R233	RP1	Pointer 1 Register	xx	37
		R234	PPR	Page Pointer Register	xx	39
		R235	MODER	Mode Register	E0	39
		R236	USPHR	User Stack Pointer High Register	xx	41
		R237	USPLR	User Stack Pointer Low Register	xx	41
		R238	SSPHR	System Stack Pointer High Reg.	xx	41
	R239	SSPLR	System Stack Pointer Low Reg.	xx	41	
	I/O Port 0:5	R224	P0DR	Port 0 Data Register	FF	151
		R225	P1DR	Port 1 Data Register	FF	
		R226	P2DR	Port 2 Data Register	FF	
		R227	P3DR	Port 3 Data Register	1111 111x	
R228		P4DR	Port 4 Data Register	FF		
R229		P5DR	Port 5 Data Register	FF		
0	INT	R242	EITR	External Interrupt Trigger Register	00	106
		R243	EIPR	External Interrupt Pending Reg.	00	107
		R244	EIMR	External Interrupt Mask-bit Reg.	00	107
		R245	EIPLR	External Interrupt Priority Level Reg.	FF	107
		R246	EIVR	External Interrupt Vector Register	x6	163
		R247	NICR	Nested Interrupt Control	00	108
	WDT	R248	WDTHR	Watchdog Timer High Register	FF	162
		R249	WDTLR	Watchdog Timer Low Register	FF	162
		R250	WDTPR	Watchdog Timer Prescaler Reg.	FF	162
		R251	WDTCR	Watchdog Timer Control Register	12	162
R252	WCR	Wait Control Register	7F	163		
2	I/O Port 0	R240	P0C0	Port 0 Configuration Register 0	00	151
		R241	P0C1	Port 0 Configuration Register 1	00	
		R242	P0C2	Port 0 Configuration Register 2	00	
	I/O Port 1	R244	P1C0	Port 1 Configuration Register 0	00	
		R245	P1C1	Port 1 Configuration Register 1	00	
		R246	P1C2	Port 1 Configuration Register 2	00	
	I/O Port 2	R248	P2C0	Port 2 Configuration Register 0	FF	
		R249	P2C1	Port 2 Configuration Register 1	00	
		R250	P2C2	Port 2 Configuration Register 2	00	
	I/O Port 3	R252	P3C0	Port 3 Configuration Register 0	1111 111x	
R253		P3C1	Port 3 Configuration Register 1	0000 000x		
R254		P3C2	Port 3 Configuration Register 2	0000 000x		

ST92F124/F150/F250 - REGISTER AND MEMORY MAP

Page (Dec)	Block	Reg. No.	Register Name	Description	Reset Value Hex.	Doc. Page
3	I/O Port 4	R240	P4C0	Port 4 Configuration Register 0	FD	151
		R241	P4C1	Port 4 Configuration Register 1	00	
		R242	P4C2	Port 4 Configuration Register 2	00	
	I/O Port 5	R244	P5C0	Port 5 Configuration Register 0	FF	
		R245	P5C1	Port 5 Configuration Register 1	00	
		R246	P5C2	Port 5 Configuration Register 2	00	
	I/O Port 6	R248	P6C0	Port 6 Configuration Register 0	xx11 1111	
		R249	P6C1	Port 6 Configuration Register 1	xx00 0000	
		R250	P6C2	Port 6 Configuration Register 2	xx00 0000	
		R251	P6DR	Port 6 Data Register	xx11 1111	
	I/O Port 7	R252	P7C0	Port 7 Configuration Register 0	FF	
		R253	P7C1	Port 7 Configuration Register 1	00	
		R254	P7C2	Port 7 Configuration Register 2	00	
		R255	P7DR	Port 7 Data Register	FF	
7	SPI	R240	SPDR0	SPI Data Register	00	260
		R241	SPCR0	SPI Control Register	00	260
		R242	SPSR0	SPI Status Register	00	261
		R243	SPPR0	SPI Prescaler Register	00	261

Page (Dec)	Block	Reg. No.	Register Name	Description	Reset Value Hex.	Doc. Page		
8	MFT1	R240	REG0HR1	Capture Load Register 0 High	xx	202		
		R241	REG0LR1	Capture Load Register 0 Low	xx	202		
		R242	REG1HR1	Capture Load Register 1 High	xx	202		
		R243	REG1LR1	Capture Load Register 1 Low	xx	202		
		R244	CMP0HR1	Compare 0 Register High	00	202		
		R245	CMP0LR1	Compare 0 Register Low	00	202		
		R246	CMP1HR1	Compare 1 Register High	00	202		
		R247	CMP1LR1	Compare 1 Register Low	00	202		
		R248	TCR1	Timer Control Register	00	203		
		R249	TMR1	Timer Mode Register	00	204		
		R250	T_ICR1	External Input Control Register	00	205		
		R251	PRSR1	Prescaler Register	00	205		
		R252	OACR1	Output A Control Register	00	206		
		R253	OBCR1	Output B Control Register	00	207		
		R254	T_FLAGR1	Flags Register	00	207		
		9	MFT0,1	R244	DCPR1	DMA Counter Pointer Register	xx	202
				R245	DAPR1	DMA Address Pointer Register	xx	202
R246	T_IVR1			Interrupt Vector Register	xx	202		
R247	IDCR1			Interrupt/DMA Control Register	C7	202		
R248	IOCR			I/O Connection Register	FC	211		
10	MFT0	R240	DCPR0	DMA Counter Pointer Register	xx	209		
		R241	DAPR0	DMA Address Pointer Register	xx	210		
		R242	T_IVR0	Interrupt Vector Register	xx	210		
		R243	IDCR0	Interrupt/DMA Control Register	C7	211		
		R240	REG0HR0	Capture Load Register 0 High	xx	202		
		R241	REG0LR0	Capture Load Register 0 Low	xx	202		
		R242	REG1HR0	Capture Load Register 1 High	xx	202		
		R243	REG1LR0	Capture Load Register 1 Low	xx	202		
		R244	CMP0HR0	Compare 0 Register High	00	202		
		R245	CMP0LR0	Compare 0 Register Low	00	202		
		R246	CMP1HR0	Compare 1 Register High	00	202		
		R247	CMP1LR0	Compare 1 Register Low	00	202		
		R248	TCR0	Timer Control Register	00	203		
		R249	TMR0	Timer Mode Register	00	204		
		R250	T_ICR0	External Input Control Register	00	205		
		R251	PRSR0	Prescaler Register	00	205		
		R252	OACR0	Output A Control Register	00	206		
R253	OBCR0	Output B Control Register	00	207				
R254	T_FLAGR0	Flags Register	00	207				
R255	IDMR0	Interrupt/DMA Mask Register	00	209				

ST92F124/F150/F250 - REGISTER AND MEMORY MAP

Page (Dec)	Block	Reg. No.	Register Name	Description	Reset Value Hex.	Doc. Page
11	STIM	R240	STH	Counter High Byte Register	FF	166
		R241	STL	Counter Low Byte Register	FF	166
		R242	STP	Standard Timer Prescaler Register	FF	166
		R243	STC	Standard Timer Control Register	14	166
20	I2C_0	R240	I2DCCR	I ² C Control Register	00	273
		R241	I2CSR1	I ² C Status Register 1	00	274
		R242	I2CSR2	I ² C Status Register 2	00	276
		R243	I2CCCR	I ² C Clock Control Register	00	277
		R244	I2COAR1	I ² C Own Address Register 1	00	277
		R245	I2COAR2	I ² C Own Address Register 2	00	278
		R246	I2CDR	I ² C Data Register	00	278
		R247	I2CADR	I ² C General Call Address	A0	278
		R248	I2CISR	I ² C Interrupt Status Register	xx	279
		R249	I2CIVR	I ² C Interrupt Vector Register	xx	280
		R250	I2CRDAP	Receiver DMA Source Addr. Pointer	xx	280
		R251	I2CRDC	Receiver DMA Transaction Counter	xx	280
		R252	I2CTDAP	Transmitter DMA Source Addr. Pointer	xx	281
		R253	I2CTDC	Transmitter DMA Transaction Counter	xx	281
		R254	I2CECCR	Extended Clock Control Register	00	281
R255	I2CIMR	I ² C Interrupt Mask Register	x0	282		
21	MMU	R240	DPR0	Data Page Register 0	xx	46
		R241	DPR1	Data Page Register 1	xx	46
		R242	DPR2	Data Page Register 2	xx	46
		R243	DPR3	Data Page Register 3	xx	46
		R244	CSR	Code Segment Register	00	47
		R248	ISR	Interrupt Segment Register	xx	47
		R249	DMASR	DMA Segment Register	xx	47
	EXTMI	R245	EMR1	External Memory Register 1	80	148
		R246	EMR2	External Memory Register 2	1F	149

Page (Dec)	Block	Reg. No.	Register Name	Description	Reset Value Hex.	Doc. Page
22	I2C_1*	R240	I2DCCR	I ² C Control Register	00	273
		R241	I2CSR1	I ² C Status Register 1	00	274
		R242	I2CSR2	I ² C Status Register 2	00	276
		R243	I2CCCR	I ² C Clock Control Register	00	277
		R244	I2COAR1	I ² C Own Address Register 1	00	277
		R245	I2COAR2	I ² C Own Address Register 2	00	278
		R246	I2CDR	I ² C Data Register	00	278
		R247	I2CADR	I ² C General Call Address	A0	278
		R248	I2CISR	I ² C Interrupt Status Register	xx	279
		R249	I2CIVR	I ² C Interrupt Vector Register	xx	280
		R250	I2CRDAP	Receiver DMA Source Addr. Pointer	xx	280
		R251	I2CRDC	Receiver DMA Transaction Counter	xx	280
		R252	I2CTDAP	Transmitter DMA Source Addr. Pointer	xx	281
		R253	I2CTDC	Transmitter DMA Transaction Counter	xx	281
		R254	I2CECCR	Extended Clock Control Register	00	281
		R255	I2CIMR	I ² C Interrupt Mask Register	x0	282
23	JBLPD*	R240	STATUS	Status Register	40	305
		R241	TXDATA	Transmit Data Register	xx	306
		R242	RXDATA	Receive Data Register	xx	307
		R243	TXOP	Transmit Opcode Register	00	307
		R244	CLKSEL	System Frequency Selection Register	00	312
		R245	CONTROL	Control Register	40	312
		R246	PADDR	Physical Address Register	xx	313
		R247	ERROR	Error Register	00	314
		R248	IVR	Interrupt Vector Register	xx	316
		R249	PRLR	Priority Level Register	10	316
		R250	IMR	Interrupt Mask Register	00	316
		R251	OPTIONS	Options and Register Group Selection	00	318
		R252	CREG0	Current Register 0	xx	320
		R253	CREG1	Current Register 1	xx	320
		R254	CREG2	Current Register 2	xx	320
		R255	CREG3	Current Register 4	xx	320

ST92F124/F150/F250 - REGISTER AND MEMORY MAP

Page (Dec)	Block	Reg. No.	Register Name	Description	Reset Value Hex.	Doc. Page		
24	SCI-M	R240	RDCPR0	Receiver DMA Transaction Counter Pointer	xx	227		
		R241	RDAPR0	Receiver DMA Source Address Pointer	xx	227		
		R242	TDCPR0	Transmitter DMA Transaction Counter Pointer	xx	227		
		R243	TDAPR0	Transmitter DMA Destination Address Pointer	xx	227		
		R244	S_IVR0	Interrupt Vector Register	xx	229		
		R245	ACR0	Address/Data Compare Register	xx	229		
		R246	IMR0	Interrupt Mask Register	x0	229		
		R247	S_ISR0	Interrupt Status Register	xx	229		
		R248	RXBR0	Receive Buffer Register	xx	231		
		R248	TXBR0	Transmitter Buffer Register	xx	231		
		R249	IDPR0	Interrupt/DMA Priority Register	xx	232		
		R250	CHCR0	Character Configuration Register	xx	233		
		R251	CCR0	Clock Configuration Register	00	234		
		R252	BRGHR0	Baud Rate Generator High Reg.	xx	235		
		R253	BRGLR0	Baud Rate Generator Low Register	xx	235		
		26	SCI-A*	R240	SCISR	SCI Status Register	C0	245
				R241	SCIDR	SCI Data Register	xx	248
R242	SCIBRR			SCI Baud Rate Register	xx	248		
R243	SCICR1			SCI Control Register 1	xx	246		
R244	SCICR2			SCI Control Register 2	00	247		
R245	SCIERPR			SCI Extended Receive Prescaler Register	00	249		
R246	SCIETPR			SCI Extended Transmit Prescaler Register	00	249		
R255	SCICR3			SCI Control Register 3	00	247		
28	EFT0*	R240	IC1HR0	Input Capture 1 High Register	xx	181		
		R241	IC1LR0	Input Capture 1 Low Register	xx	181		
		R242	IC2HR0	Input Capture 2 High Register	xx	181		
		R243	IC2LR0	Input Capture 2 Low Register	xx	181		
		R244	CHR0	Counter High Register	FF	182		
		R245	CLR0	Counter Low Register	FC	182		
		R246	ACHR0	Alternate Counter High Register	FF	182		
		R247	ACLR0	Alternate Counter Low Register	FC	182		
		R248	OC1HR0	Output Compare 1 High Register	80	183		
		R249	OC1LR0	Output Compare 1 Low Register	00	183		
		R250	OC2HR0	Output Compare 2 High Register	80	183		
		R251	OC2LR0	Output Compare 2 Low Register	00	183		
		R252	CR1_0	Control Register 1	00	185		
		R253	CR2_0	Control Register 2	00	185		
		R254	SR0	Status Register	00	185		
R255	CR3_0	Control Register 3	00	185				

Page (Dec)	Block	Reg. No.	Register Name	Description	Reset Value Hex.	Doc. Page
29	EFT1*	R240	IC1HR1	Input Capture 1 High Register	xx	181
		R241	IC1LR1	Input Capture 1 Low Register	xx	181
		R242	IC2HR1	Input Capture 2 High Register	xx	181
		R243	IC2LR1	Input Capture 2 Low Register	xx	181
		R244	CHR1	Counter High Register	FF	182
		R245	CLR1	Counter Low Register	FC	182
		R246	ACHR1	Alternate Counter High Register	FF	182
		R247	ACLR1	Alternate Counter Low Register	FC	182
		R248	OC1HR1	Output Compare 1 High Register	80	183
		R249	OC1LR1	Output Compare 1 Low Register	00	183
		R250	OC2HR1	Output Compare 2 High Register	80	183
		R251	OC2LR1	Output Compare 2 Low Register	00	183
		R252	CR1_1	Control Register 1	00	185
		R253	CR2_1	Control Register 2	00	185
		R254	SR1	Status Register	00	185
		R255	CR3_1	Control Register 3	00	185
36	CAN1* Control/ Status	R240	CMCR	CAN Master Control Register	02	343
		R241	CMSR	CAN Master Status Register	02	344
		R242	CTSR	CAN Transmit Control Register	00	344
		R243	CTPR	CAN Transmit Priority Register	00	345
		R244	CRFR0	CAN Receive FIFO Register 0	00	346
		R245	CRFR1	CAN Receive FIFO Register 1	00	346
		R246	CIER	CAN Interrupt Enable Register	00	346
		R247	CESR	CAN Error Status Register	00	347
		R248	CEIER	CAN Error Interrupt Enable Register	00	347
		R249	TECR	Transmit Error Counter Register	00	348
		R250	RECR	Receive Error Counter Register	00	348
		R251	CDGR	CAN Diagnosis Register	00	348
		R252	CBTR0	CAN Bit Timing Register 0	00	349
		R253	CBTR1	CAN Bit Timing Register 1	23	349
R255	CFPSR	Filter page Select Register	00	349		

ST92F124/F150/F250 - REGISTER AND MEMORY MAP

Page (Dec)	Block	Reg. No.	Register Name	Description	Reset Value Hex.	Doc. Page
37	CAN1* Receive FIFO 0	R240	MFMI	Mailbox Filter Match Index	00	351
		R241	MDLC	Mailbox Data Length Control Register	xx	352
		R242	MIDR0	Mailbox Identifier Register 0	xx	351
		R243	MIDR1	Mailbox Identifier Register 1	xx	351
		R244	MIDR2	Mailbox Identifier Register 2	xx	351
		R245	MIDR3	Mailbox Identifier Register 3	xx	351
		R246	MDAR0	Mailbox Data Register 0	xx	352
		R247	MDAR1	Mailbox Data Register 1	xx	352
		R248	MDAR2	Mailbox Data Register 2	xx	352
		R249	MDAR3	Mailbox Data Register 3	xx	352
		R250	MDAR4	Mailbox Data Register 4	xx	352
		R251	MDAR5	Mailbox Data Register 5	xx	352
		R252	MDAR6	Mailbox Data Register 6	xx	352
		R253	MDAR7	Mailbox Data Register 7	xx	352
		R254	MTSLR	Mailbox Time Stamp Low Register	xx	352
R255	MTSHR	Mailbox Time Stamp High Register	xx	352		
38	CAN1* Receive FIFO 1	R240	MFMI	Mailbox Filter Match Index	00	351
		R241	MDLC	Mailbox Data Length Control Register	xx	352
		R242	MIDR0	Mailbox Identifier Register 0	xx	351
		R243	MIDR1	Mailbox Identifier Register 1	xx	351
		R244	MIDR2	Mailbox Identifier Register 2	xx	351
		R245	MIDR3	Mailbox Identifier Register 3	xx	351
		R246	MDAR0	Mailbox Data Register 0	xx	352
		R247	MDAR1	Mailbox Data Register 1	xx	352
		R248	MDAR2	Mailbox Data Register 2	xx	352
		R249	MDAR3	Mailbox Data Register 3	xx	352
		R250	MDAR4	Mailbox Data Register 4	xx	352
		R251	MDAR5	Mailbox Data Register 5	xx	352
		R252	MDAR6	Mailbox Data Register 6	xx	352
		R253	MDAR7	Mailbox Data Register 7	xx	352
		R254	MTSLR	Mailbox Time Stamp Low Register	xx	352
R255	MTSHR	Mailbox Time Stamp High Register	xx	352		

Page (Dec)	Block	Reg. No.	Register Name	Description	Reset Value Hex.	Doc. Page
39	CAN1 * Tx Mailbox 0	R240	MCSR	Mailbox Control Status Register	00	350
		R241	MDLC	Mailbox Data Length Control Register	xx	352
		R242	MIDR0	Mailbox Identifier Register 0	xx	351
		R243	MIDR1	Mailbox Identifier Register 1	xx	351
		R244	MIDR2	Mailbox Identifier Register 2	xx	351
		R245	MIDR3	Mailbox Identifier Register 3	xx	351
		R246	MDAR0	Mailbox Data Register 0	xx	352
		R247	MDAR1	Mailbox Data Register 1	xx	352
		R248	MDAR2	Mailbox Data Register 2	xx	352
		R249	MDAR3	Mailbox Data Register 3	xx	352
		R250	MDAR4	Mailbox Data Register 4	xx	352
		R251	MDAR5	Mailbox Data Register 5	xx	352
		R252	MDAR6	Mailbox Data Register 6	xx	352
		R253	MDAR7	Mailbox Data Register 7	xx	352
		R254	MTSLR	Mailbox Time Stamp Low Register	xx	352
R255	MTSHR	Mailbox Time Stamp High Register	xx	352		
40	CAN1 * Tx Mailbox 1	R240	MCSR	Mailbox Control Status Register	00	350
		R241	MDLC	Mailbox Data Length Control Register	xx	352
		R242	MIDR0	Mailbox Identifier Register 0	xx	351
		R243	MIDR1	Mailbox Identifier Register 1	xx	351
		R244	MIDR2	Mailbox Identifier Register 2	xx	351
		R245	MIDR3	Mailbox Identifier Register 3	xx	351
		R246	MDAR0	Mailbox Data Register 0	xx	352
		R247	MDAR1	Mailbox Data Register 1	xx	352
		R248	MDAR2	Mailbox Data Register 2	xx	352
		R249	MDAR3	Mailbox Data Register 3	xx	352
		R250	MDAR4	Mailbox Data Register 4	xx	352
		R251	MDAR5	Mailbox Data Register 5	xx	352
		R252	MDAR6	Mailbox Data Register 6	xx	352
		R253	MDAR7	Mailbox Data Register 7	xx	352
		R254	MTSLR	Mailbox Time Stamp Low Register	xx	352
R255	MTSHR	Mailbox Time Stamp High Register	xx	352		

ST92F124/F150/F250 - REGISTER AND MEMORY MAP

Page (Dec)	Block	Reg. No.	Register Name	Description	Reset Value Hex.	Doc. Page
41	CAN1 * Tx Mailbox 2	R240	MCSR	Mailbox Control Status Register	00	350
		R241	MDLC	Mailbox Data Length Control Register	x0	352
		R242	MIDR0	Mailbox Identifier Register 0	xx	351
		R243	MIDR1	Mailbox Identifier Register 1	xx	351
		R244	MIDR2	Mailbox Identifier Register 2	xx	351
		R245	MIDR3	Mailbox Identifier Register 3	xx	351
		R246	MDAR0	Mailbox Data Register 0	xx	352
		R247	MDAR1	Mailbox Data Register 1	xx	352
		R248	MDAR2	Mailbox Data Register 2	xx	352
		R249	MDAR3	Mailbox Data Register 3	xx	352
		R250	MDAR4	Mailbox Data Register 4	xx	352
		R251	MDAR5	Mailbox Data Register 5	xx	352
		R252	MDAR6	Mailbox Data Register 6	xx	352
		R253	MDAR7	Mailbox Data Register 7	xx	352
		R254	MTSLR	Mailbox Time Stamp Low Register	xx	352
R255	MTSHR	Mailbox Time Stamp High Register	xx	352		
42	CAN1 * Filters	See "Page Mapping for CAN 0 / CAN 1" on page 357		Filter Configuration Acceptance Filters 7:0 (5 register pages)		
43	I/O Port 8 *	R248	P8C0	Port 8 Configuration Register 0	03	151
		R249	P8C1	Port 8 Configuration Register 1	00	
		R250	P8C2	Port 8 Configuration Register 2	00	
		R251	P8DR	Port 8 Data Register	FF	
	I/O Port 9 *	R252	P9C0	Port 9 Configuration Register 0	00	
		R253	P9C1	Port 9 Configuration Register 1	00	
		R254	P9C2	Port 9 Configuration Register 2	00	
		R255	P9DR	Port 9 Data Register	FF	
48	CAN0* Control/ Status	R240	CMCR	CAN Master Control Register	02	343
		R241	CMSR	CAN Master Status Register	02	344
		R242	CTSR	CAN Transmit Control Register	00	344
		R243	CTPR	CAN Transmit Priority Register	00	345
		R244	CRFR0	CAN Receive FIFO Register 0	00	346
		R245	CRFR1	CAN Receive FIFO Register 1	00	346
		R246	CIER	CAN Interrupt Enable Register	00	346
		R247	CESR	CAN Error Status Register	00	347
		R248	CEIER	CAN Error Interrupt Enable Register	00	347
		R249	TECR	Transmit Error Counter Register	00	348
		R250	RECR	Receive Error Counter Register	00	348
		R251	CDGR	CAN Diagnosis Register	00	348
		R252	CBTR0	CAN Bit Timing Register 0	00	349
		R253	CBTR1	CAN Bit Timing Register 1	23	349
		R255	CFPSR	Filter page Select Register	00	349

Page (Dec)	Block	Reg. No.	Register Name	Description	Reset Value Hex.	Doc. Page
49	CAN0* Receive FIFO 0	R240	MFMI	Mailbox Filter Match Index	00	351
		R241	MDLC	Mailbox Data Length Control Register	xx	352
		R242	MIDR0	Mailbox Identifier Register 0	xx	351
		R243	MIDR1	Mailbox Identifier Register 1	xx	351
		R244	MIDR2	Mailbox Identifier Register 2	xx	351
		R245	MIDR3	Mailbox Identifier Register 3	xx	351
		R246	MDAR0	Mailbox Data Register 0	xx	352
		R247	MDAR1	Mailbox Data Register 1	xx	352
		R248	MDAR2	Mailbox Data Register 2	xx	352
		R249	MDAR3	Mailbox Data Register 3	xx	352
		R250	MDAR4	Mailbox Data Register 4	xx	352
		R251	MDAR5	Mailbox Data Register 5	xx	352
		R252	MDAR6	Mailbox Data Register 6	xx	352
		R253	MDAR7	Mailbox Data Register 7	xx	352
		R254	MTSLR	Mailbox Time Stamp Low Register	xx	352
R255	MTSHR	Mailbox Time Stamp High Register	xx	352		
50	CAN0* Receive FIFO 1	R240	MFMI	Mailbox Filter Match Index	00	351
		R241	MDLC	Mailbox Data Length Control Register	xx	352
		R242	MIDR0	Mailbox Identifier Register 0	xx	351
		R243	MIDR1	Mailbox Identifier Register 1	xx	351
		R244	MIDR2	Mailbox Identifier Register 2	xx	351
		R245	MIDR3	Mailbox Identifier Register 3	xx	351
		R246	MDAR0	Mailbox Data Register 0	xx	352
		R247	MDAR1	Mailbox Data Register 1	xx	352
		R248	MDAR2	Mailbox Data Register 2	xx	352
		R249	MDAR3	Mailbox Data Register 3	xx	352
		R250	MDAR4	Mailbox Data Register 4	xx	352
		R251	MDAR5	Mailbox Data Register 5	xx	352
		R252	MDAR6	Mailbox Data Register 6	xx	352
		R253	MDAR7	Mailbox Data Register 7	xx	352
		R254	MTSLR	Mailbox Time Stamp Low Register	xx	352
R255	MTSHR	Mailbox Time Stamp High Register	xx	352		

ST92F124/F150/F250 - REGISTER AND MEMORY MAP

Page (Dec)	Block	Reg. No.	Register Name	Description	Reset Value Hex.	Doc. Page
51	CAN0* Tx Mailbox 0	R240	MCSR	Mailbox Control Status Register	00	350
		R241	MDLC	Mailbox Data Length Control Register	xx	352
		R242	MIDR0	Mailbox Identifier Register 0	xx	351
		R243	MIDR1	Mailbox Identifier Register 1	xx	351
		R244	MIDR2	Mailbox Identifier Register 2	xx	351
		R245	MIDR3	Mailbox Identifier Register 3	xx	351
		R246	MDAR0	Mailbox Data Register 0	xx	352
		R247	MDAR1	Mailbox Data Register 1	xx	352
		R248	MDAR2	Mailbox Data Register 2	xx	352
		R249	MDAR3	Mailbox Data Register 3	xx	352
		R250	MDAR4	Mailbox Data Register 4	xx	352
		R251	MDAR5	Mailbox Data Register 5	xx	352
		R252	MDAR6	Mailbox Data Register 6	xx	352
		R253	MDAR7	Mailbox Data Register 7	xx	352
		R254	MTSLR	Mailbox Time Stamp Low Register	xx	352
R255	MTSHR	Mailbox Time Stamp High Register	xx	352		
52	CAN0* Tx Mailbox 1	R240	MCSR	Mailbox Control Status Register	00	350
		R241	MDLC	Mailbox Data Length Control Register	xx	352
		R242	MIDR0	Mailbox Identifier Register 0	xx	351
		R243	MIDR1	Mailbox Identifier Register 1	xx	351
		R244	MIDR2	Mailbox Identifier Register 2	xx	351
		R245	MIDR3	Mailbox Identifier Register 3	xx	351
		R246	MDAR0	Mailbox Data Register 0	xx	352
		R247	MDAR1	Mailbox Data Register 1	xx	352
		R248	MDAR2	Mailbox Data Register 2	xx	352
		R249	MDAR3	Mailbox Data Register 3	xx	352
		R250	MDAR4	Mailbox Data Register 4	xx	352
		R251	MDAR5	Mailbox Data Register 5	xx	352
		R252	MDAR6	Mailbox Data Register 6	xx	352
		R253	MDAR7	Mailbox Data Register 7	xx	352
		R254	MTSLR	Mailbox Time Stamp Low Register	xx	352
R255	MTSHR	Mailbox Time Stamp High Register	xx	352		

Page (Dec)	Block	Reg. No.	Register Name	Description	Reset Value Hex.	Doc. Page
53	CAN0* Tx Mailbox 2	R240	MCSR	Mailbox Control Status Register	00	350
		R241	MDLC	Mailbox Data Length Control Register	xx	352
		R242	MIDR0	Mailbox Identifier Register 0	xx	351
		R243	MIDR1	Mailbox Identifier Register 1	xx	351
		R244	MIDR2	Mailbox Identifier Register 2	xx	351
		R245	MIDR3	Mailbox Identifier Register 3	xx	351
		R246	MDAR0	Mailbox Data Register 0	xx	352
		R247	MDAR1	Mailbox Data Register 1	xx	352
		R248	MDAR2	Mailbox Data Register 2	xx	352
		R249	MDAR3	Mailbox Data Register 3	xx	352
		R250	MDAR4	Mailbox Data Register 4	xx	352
		R251	MDAR5	Mailbox Data Register 5	xx	352
		R252	MDAR6	Mailbox Data Register 6	xx	352
		R253	MDAR7	Mailbox Data Register 7	xx	352
R254	MTSLR	Mailbox Time Stamp Low Register	xx	352		
R255	MTSHR	Mailbox Time Stamp High Register	xx	352		
54	CAN0* Filters	"Page Mapping for CAN 0 / CAN 1" on page 357		Filter Configuration Acceptance Filters 7:0 (5 register pages)		
55	RCCU	R240	CLKCTL	Clock Control Register	00	134
		R241	VRCTR	Voltage Regulator Control Register	0x	134
		R242	CLK_FLAG	Clock Flag Register	64,48, 28 or 08	135
		R246	PLLCONF	PLL Configuration Register	xx	135
57	WUIMU	R249	WUCTRL	Wake-Up Control Register	00	118
		R250	WUMRH	Wake-Up Mask Register High	00	119
		R251	WUMRL	Wake-Up Mask Register Low	00	119
		R252	WUTRH	Wake-Up Trigger Register High	00	120
		R253	WUTRL	Wake-Up Trigger Register Low	00	120
		R254	WUPRH	Wake-Up Pending Register High	00	120
		R255	WUPRL	Wake-Up Pending Register Low	00	120
60	STD INT	R245	SIMRH	Interrupt Mask Register High (Ch. I to L)	00	109
		R246	SIMRL	Interrupt Mask Register Low (Ch. E to H)	00	109
		R247	SITRH	Interrupt Trigger Register High (Ch. I to L)	00	109
		R248	SITRL	Interrupt Trigger Register Low (Ch. E to H)	00	109
		R249	SIPRH	Interrupt Pending Register High (Ch. I to L)	00	109
		R250	SIPRL	Interrupt Pending Register Low (Ch. E to H)	00	109
		R251	SIVR	Interrupt Vector Register (Ch. E to L)	xE	110
		R252	SIPLRH	Interrupt Priority Register High (Ch. I to L)	FF	110
		R253	SIPLRL	Interrupt Priority Register Low (Ch. E to H)	FF	110
		R254	SFLAGRH	Interrupt Flag Register High (Ch. I to L)	00	111
		R255	SIFLAGRL	Interrupt Flag Register Low (Ch. E to H)	00	111

ST92F124/F150/F250 - REGISTER AND MEMORY MAP

Page (Dec)	Block	Reg. No.	Register Name	Description	Reset Value Hex.	Doc. Page
61	ADC	R240	D0HR	Channel 0 Data High Register	xx	366
		R241	D0LR	Channel 0 Data Low Register	x0	366
		R242	D1HR	Channel 1 Data High Register	xx	366
		R243	D1LR	Channel 1 Data Low Register	x0	366
		R244	D2HR	Channel 2 Data High Register	xx	366
		R245	D2LR	Channel 2 Data Low Register	x0	366
		R246	D3HR	Channel 3 Data High Register	xx	366
		R247	D3LR	Channel 3 Data Low Register	x0	366
		R248	D4HR	Channel 4 Data High Register	xx	367
		R249	D4LR	Channel 4 Data Low Register	x0	367
		R250	D5HR	Channel 5 Data High Register	xx	367
		R251	D5LR	Channel 5 Data Low Register	x0	367
		R252	D6HR	Channel 6 Data High Register	xx	367
		R253	D6LR	Channel 6 Data Low Register	x0	367
		R254	D7HR	Channel 7 Data High Register	xx	367
R255		D7LR	Channel 7 Data Low Register	x0	367	
62		R240	D8HR	Channel 8 Data High Register	xx	368
		R241	D8LR	Channel 8 Data Low Register	x0	368
		R242	D9HR	Channel 9 Data High Register	xx	368
		R243	D9LR	Channel 9 Data Low Register	x0	368
		R244	D10HR	Channel 10 Data High Register	xx	368
		R245	D10LR	Channel 10 Data Low Register	x0	368
		R246	D11HR	Channel 11 Data High Register	xx	368
		R247	D11LR	Channel 11 Data Low Register	x0	368
		R248	D12HR	Channel 12 Data High Register	xx	369
		R249	D12LR	Channel 12 Data Low Register	x0	369
		R250	D13HR	Channel 13 Data High Register	xx	369
		R251	D13LR	Channel 13 Data Low Register	x0	369
		R252	D14HR	Channel 14 Data High Register	xx	369
		R253	D14LR	Channel 14 Data Low Register	x0	369
	R254	D15HR	Channel 15 Data High Register	xx	369	
R255	D15LR	Channel 15 Data Low Register	x0	369		

Page (Dec)	Block	Reg. No.	Register Name	Description	Reset Value Hex.	Doc. Page
63	ADC	R243	CRR	Compare Result Register	0x	370
		R244	LTAHR	Channel A Lower Threshold High Register	xx	370
		R245	LTALR	Channel A Lower Threshold Low Register	x0	370
		R246	LTBHR	Channel B Lower Threshold High Register	xx	370
		R247	LTBLR	Channel B Lower Threshold Low Register	x0	371
		R248	UTAHR	Channel A Upper Threshold High Register	xx	371
		R249	UTALR	Channel A Upper Threshold Low Register	x0	371
		R250	UTBHR	Channel B Upper Threshold High Register	xx	371
		R251	UTBLR	Channel B Upper Threshold Low Register	x0	371
		R252	CLR1	Control Logic Register 1	0F	372
		R253	CLR2	Control Logic Register 2	A0	372
		R254	AD_ICR	Interrupt Control Register	0F	373
		R255	AD_IVR	Interrupt Vector Register	x2	374

Note: xx denotes a byte with an undefined value, however some of the bits may have defined values. Refer to register description for details.

* Available on some devices only

5 INTERRUPTS

5.1 INTRODUCTION

The ST9 responds to peripheral and external events through its interrupt channels. Current program execution can be suspended to allow the ST9 to execute a specific response routine when such an event occurs, providing that interrupts have been enabled, and according to a priority mechanism. If an event generates a valid interrupt request, the current program status is saved and control passes to the appropriate Interrupt Service Routine.

The ST9 CPU can receive requests from the following sources:

- On-chip peripherals
- External pins
- Top-Level Pseudo-non-maskable interrupt

5.1.1 On-Chip Peripheral Interrupt Sources

5.1.1.1 Dedicated Channels

The following on-chip peripherals have dedicated interrupt channels with interrupt control registers located in their peripheral register page.

- A/D Converter
- I²C
- JPBLD
- MFT
- SCI-M

5.1.1.2 Standard Channels

Other on-chip peripherals have their interrupts mapped to the INTxx interrupt channel group. These channels have control registers located in Pages 0 and 60. These peripherals are:

- CAN
- E³™/FLASH
- EFT Timer
- RCCU
- SCI-A
- SPI
- STIM timer
- WDT Timer
- WUIMU

5.1.1.3 External Interrupts

Up to eight external interrupts, with programmable input trigger edge, are available and are mapped to the INTxx interrupt channel group in page 0.

5.1.1.4 Top Level Interrupt (TLI)

In addition, a dedicated interrupt channel, set to the Top-level priority, can be devoted either to the external NMI pin (where available) to provide a Non-Maskable Interrupt, or to the Timer/Watch-dog. Interrupt service routines are addressed through a vector table mapped in Memory.

Figure 44. Interrupt Response

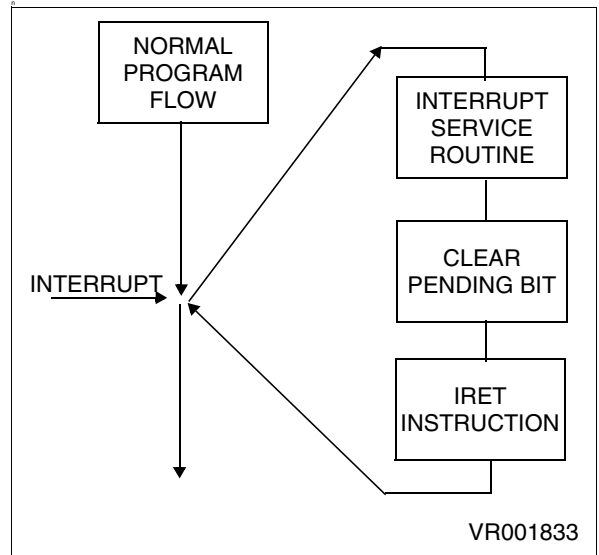

5.2 INTERRUPT VECTORING

The ST9 implements an interrupt vectoring structure which allows the on-chip peripheral to identify the location of the first instruction of the Interrupt Service Routine automatically.

When an interrupt request is acknowledged, the peripheral interrupt module provides, through its Interrupt Vector Register (IVR), a vector to point into the vector table of locations containing the start addresses of the Interrupt Service Routines (defined by the programmer).

Each peripheral has a specific IVR mapped within its Register File pages (or in register page 0 or 60 if it is mapped to one of the INTxx channels).

The Interrupt Vector table, containing the addresses of the Interrupt Service Routines, is located in the first 256 locations of Memory pointed to by the ISR register, thus allowing 8-bit vector addressing. For a description of the ISR register refer to the chapter describing the MMU.

The user Power on Reset vector is stored in the first two physical bytes in memory, 000000h and 000001h.

The Top Level Interrupt vector is located at addresses 0004h and 0005h in the segment pointed to by the Interrupt Segment Register (ISR).

If an external watchdog is used, refer to the Register and Memory Map section for details on using vector locations 0006h to 0009h. Otherwise locations 0006h to 0007h must contain FFFFh.

With one Interrupt Vector register, it is possible to address several interrupt service routines; in fact, peripherals can share the same interrupt vector register among several interrupt channels. The most significant bits of the vector are user programmable to define the base vector address within the vector table, the least significant bits are controlled by the interrupt module, in hardware, to select the appropriate vector.

Note: The first 256 locations of the memory segment pointed to by ISR can contain program code.

5.2.1 Divide by Zero trap

The Divide by Zero trap vector is located at addresses 0002h and 0003h of each code segment; it should be noted that for each code segment a Divide by Zero service routine is required.

Warning. *Although the Divide by Zero Trap operates as an interrupt, the FLAG Register is not pushed onto the system Stack automatically. As a result it must be regarded as a subroutine, and the service routine must end with the RET instruction (not IRET).*

5.2.2 Segment Paging During Interrupt Routines

The ENCSR bit in the EMR2 register can be used to select between original ST9 backward compatibility mode and ST9+ interrupt management mode.

ST9 backward compatibility mode (ENCSR = 0)

If ENCSR is reset, the CPU works in original ST9 compatibility mode. For the duration of the interrupt service routine, ISR is used instead of CSR, and the interrupt stack frame is identical to that of the original ST9: only the PC and Flags are pushed.

This avoids saving the CSR on the stack in the event of an interrupt, thus ensuring a faster interrupt response time.

It is not possible for an interrupt service routine to perform inter-segment calls or jumps: these instructions would update the CSR, which, in this case, is not used (ISR is used instead). The code segment size for all interrupt service routines is thus limited to 64K bytes.

ST9+ mode (ENCSR = 1)

If ENCSR is set, ISR is only used to point to the interrupt vector table and to initialize the CSR at the beginning of the interrupt service routine: the old CSR is pushed onto the stack together with the PC and flags, and CSR is then loaded with the contents of ISR.

In this case, `iret` will also restore CSR from the stack. This approach allows interrupt service routines to access the entire 4 Mbytes of address space. The drawback is that the interrupt response time is slightly increased, because of the need to also save CSR on the stack.

Full compatibility with the original ST9 is lost in this case, because the interrupt stack frame is different.

ENCSR Bit	0	1
Mode	ST9 Compatible	ST9+
Pushed/Popped Registers	PC, FLAGR	PC, FLAGR, CSR
Max. Code Size for interrupt service routine	64KB Within 1 segment	No limit Across segments

5.3 INTERRUPT PRIORITY LEVELS

The ST9 supports a fully programmable interrupt priority structure. Nine priority levels are available to define the channel priority relationships:

- The on-chip peripheral channels and the eight external interrupt sources can be programmed within eight priority levels. Each channel has a 3-bit field, PRL (Priority Level), that defines its priority level in the range from 0 (highest priority) to 7 (lowest priority).
- The 9th level (Top Level Priority) is reserved for the Timer/Watchdog or the External Pseudo Non-Maskable Interrupt. An Interrupt service routine at this level cannot be interrupted in any arbitration mode. Its mask can be both maskable (TLI) or non-maskable (TLNM).

5.4 PRIORITY LEVEL ARBITRATION

The 3 bits of CPL (Current Priority Level) in the Central Interrupt Control Register contain the priority of the currently running program (CPU priority). CPL is set to 7 (lowest priority) upon reset and can be modified during program execution either by software or automatically by hardware according to the selected Arbitration Mode.

During every instruction, an arbitration phase takes place, during which, for every channel capable of generating an Interrupt, each priority level is compared to all the other requests (interrupts or DMA).

If the highest priority request is an interrupt, its PRL value must be strictly lower (that is, higher priority) than the CPL value stored in the CICR register (R230) in order to be acknowledged. The Top Level Interrupt overrides every other priority.

5.4.1 Priority Level 7 (Lowest)

Interrupt requests at PRL level 7 cannot be acknowledged, as this PRL value (the lowest possible priority) cannot be strictly lower than the CPL value. This can be of use in a fully polled interrupt environment.

5.4.2 Maximum Depth of Nesting

No more than 8 routines can be nested. If an interrupt routine at level N is being serviced, no other Interrupts located at level N can interrupt it. This

guarantees a maximum number of 8 nested levels including the Top Level Interrupt request.

5.4.3 Simultaneous Interrupts

If two or more requests occur at the same time and at the same priority level, an on-chip daisy chain, specific to every ST9 version, selects the channel with the highest position in the chain, as shown in [Table 18](#)

Table 18. Daisy Chain Priority

Highest Position	INTA0 / Watchdog Timer
	INTA1 / Standard Timer
	INTB0 / Extended Function Timer 0 *
	INTB1 / Extended Function Timer 1 *
	INTC0 / E ³ ™/Flash
	INTC1 / SPI
	INTD0 / RCCU
	INTD1 / WKUP MGT
	Multifunction Timer 0
	INTE0/CAN0_RX0
	INTE1/CAN0_RX1
	INTF0/CAN0_TX
	INTF1/CAN0_SCE
	INTG0/CAN1_RX0 *
	INTG1/CAN1_RX1 *
	INTH0/CAN1_TX *
	INTH1/CAN1_SCE *
	INTI0/SCI-A *
	JBLPD *
	I ² C bus Interface 0
	I ² C bus Interface 1 *
	A/D Converter
	Lowest Position
SCI-M	

* available on some devices only

5.4.4 Dynamic Priority Level Modification

The main program and routines can be specifically prioritized. Since the CPL is represented by 3 bits in a read/write register, it is possible to dynamically modify the current priority value during program execution. This means that a critical section can have a higher priority with respect to other interrupt requests. Furthermore it is possible to prioritize even the Main Program execution by modifying the CPL during its execution. See [Figure 45](#).

Figure 45. Example of Dynamic Priority Level Modification in Nested Mode

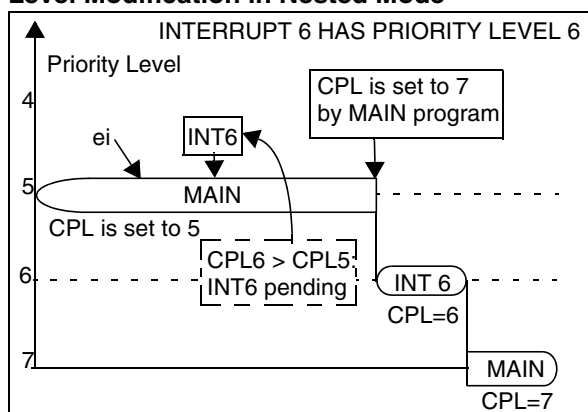

5.5 ARBITRATION MODES

The ST9 provides two interrupt arbitration modes: Concurrent mode and Nested mode. Concurrent mode is the standard interrupt arbitration mode. Nested mode improves the effective interrupt response time when service routine nesting is required, depending on the request priority levels.

The IAM control bit in the CICR Register selects Concurrent Arbitration mode or Nested Arbitration Mode.

5.5.1 Concurrent Mode

This mode is selected when the IAM bit is cleared (reset condition). The arbitration phase, performed during every instruction, selects the request with the highest priority level. The CPL value is not modified in this mode.

Start of Interrupt Routine

The interrupt cycle performs the following steps:

- All maskable interrupt requests are disabled by clearing CICR.IEN.

- The PC low byte is pushed onto system stack.
- The PC high byte is pushed onto system stack.
- If ENCSR is set, CSR is pushed onto system stack.
- The Flag register is pushed onto system stack.
- The PC is loaded with the 16-bit vector stored in the Vector Table, pointed to by the IVR.
- If ENCSR is set, CSR is loaded with ISR contents; otherwise ISR is used in place of CSR until *iret* instruction.

End of Interrupt Routine

The Interrupt Service Routine must be ended with the *iret* instruction. The *iret* instruction executes the following operations:

- The Flag register is popped from system stack.
- If ENCSR is set, CSR is popped from system stack.
- The PC high byte is popped from system stack.
- The PC low byte is popped from system stack.
- All unmasked Interrupts are enabled by setting the CICR.IEN bit.
- If ENCSR is reset, CSR is used instead of ISR.

Normal program execution thus resumes at the interrupted instruction. All pending interrupts remain pending until the next *ei* instruction (even if it is executed during the interrupt service routine).

Note: In Concurrent mode, the source priority level is only useful during the arbitration phase, where it is compared with all other priority levels and with the CPL. No trace is kept of its value during the ISR. If other requests are issued during the interrupt service routine, once the global CICR.IEN is re-enabled, they will be acknowledged regardless of the interrupt service routine's priority. This may cause undesirable interrupt response sequences.

ARBITRATION MODES (Cont'd)

Examples

In the following two examples, three interrupt requests with different priority levels (2, 3 & 4) occur simultaneously during the interrupt 5 service routine.

Example 1

In the first example, (simplest case, Figure 46) the `ei` instruction is not used within the interrupt service routines. This means that no new interrupt can be serviced in the middle of the current one. The interrupt routines will thus be serviced one after another, in the order of their priority, until the main program eventually resumes.

Figure 46. Simple Example of a Sequence of Interrupt Requests with:
 - Concurrent mode selected and
 - IEN unchanged by the interrupt routines

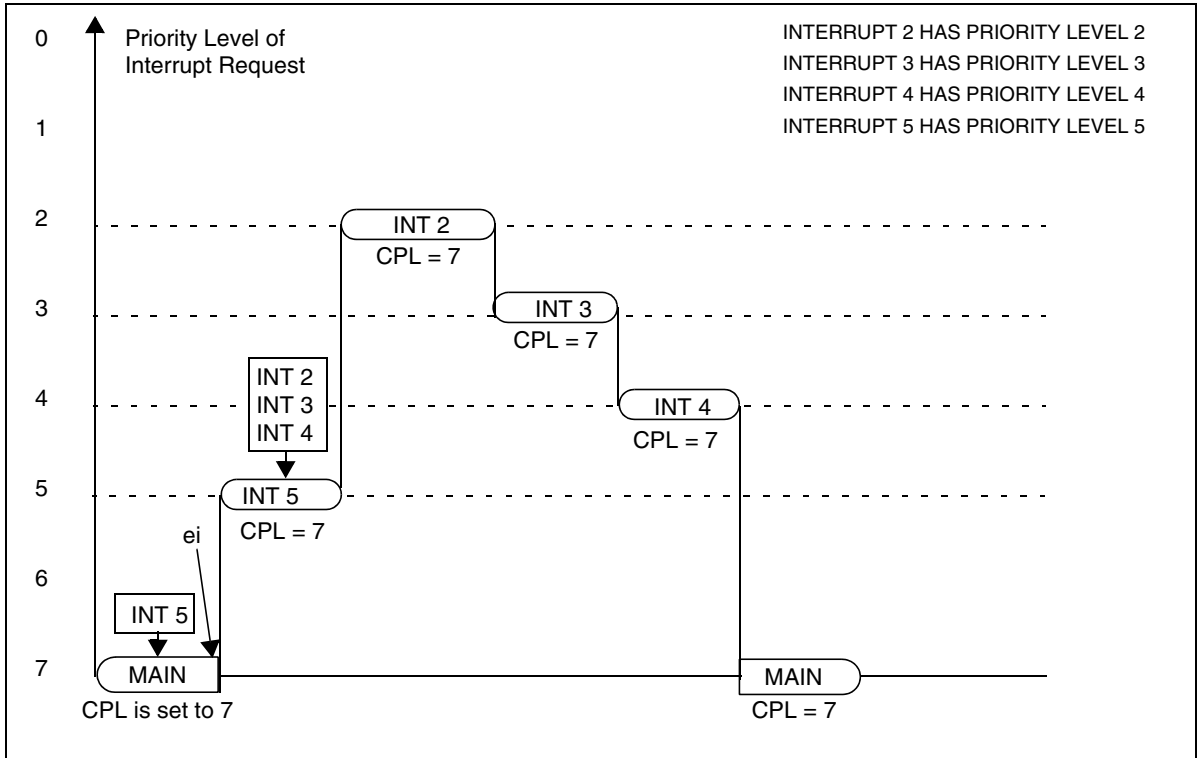

ARBITRATION MODES (Cont'd)**End of Interrupt Routine**

The `iret` Interrupt Return instruction executes the following steps:

- The Flag register is popped from system stack.
- If ENCSR is set, CSR is popped from system stack.
- The PC high byte is popped from system stack.
- The PC low byte is popped from system stack.
- All unmasked Interrupts are enabled by setting the CICR.IEN bit.
- The priority level of the interrupted routine is popped from the special register (NICR) and copied into CPL.

– If ENCSR is reset, CSR is used instead of ISR, unless the program returns to another nested routine.

The suspended routine thus resumes at the interrupted instruction.

Figure 48 contains a simple example, showing that if the `ei` instruction is not used in the interrupt service routines, nested and concurrent modes are equivalent.

Figure 49 contains a more complex example showing how nested mode allows nested interrupt processing (enabled inside the interrupt service routines) according to their priority level.

Figure 49. Complex Example of a Sequence of Interrupt Requests with:

- Nested mode
- IEN set to 1 during the interrupt routine execution

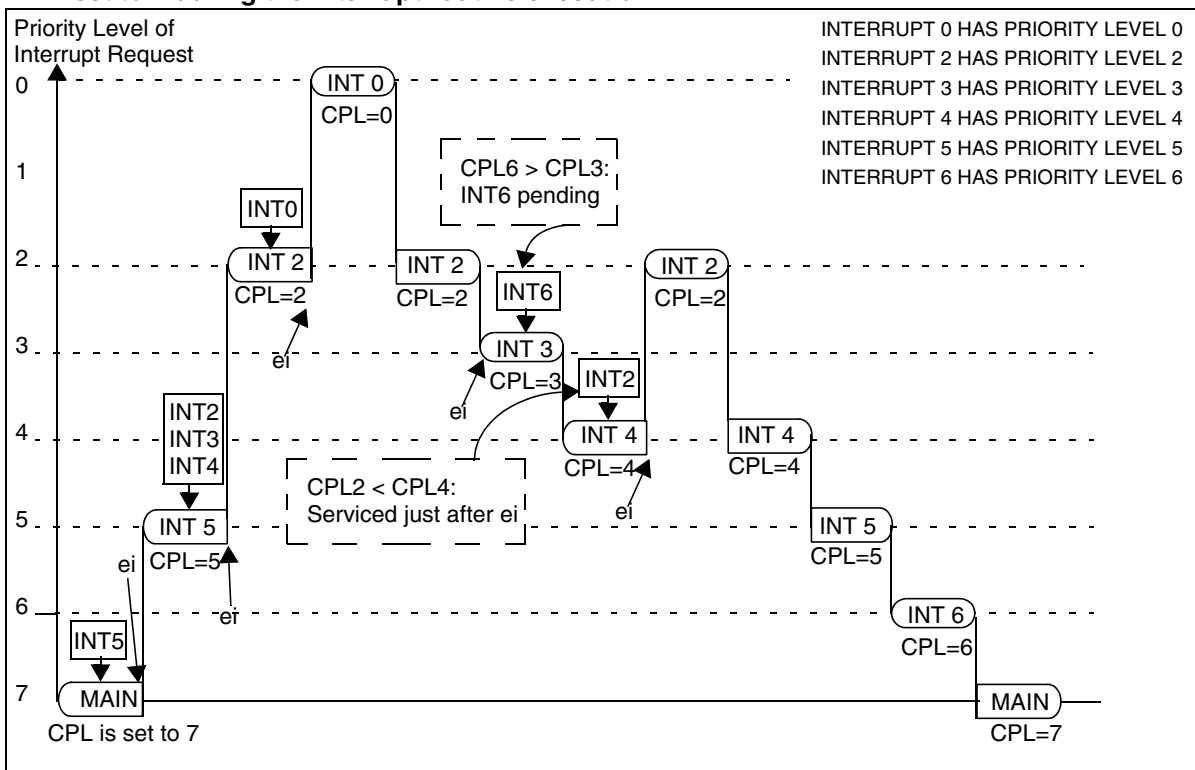

5.6 EXTERNAL INTERRUPTS

The ST9 core contains 8 external interrupt sources grouped into four pairs.

Table 19. External Interrupt Channel Grouping

External Interrupt	Channel	I/O Port Pin
WKUP[0:15]	INTD1	P8[1:0] P7[7:5] P6[7,5] P5[7:5, 2:0] P4[7,4]
INT6	INTD0	P6.1
INT5	INTC1	P6.3
INT4	INTC0	P6.2
INT3	INTB1	P6.3
INT2	INTB0	P6.2
INT1	INTA1	P6.0
INT0	INTA0	P6.0

Each source has a trigger control bit TEA0,..TED1 (R242,EITR.0,..,7 Page 0) to select triggering on the rising or falling edge of the external pin. If the Trigger control bit is set to “1”, the corresponding pending bit IPA0,..,IPD1 (R243,EIPR.0,..,7 Page 0) is set on the input pin rising edge, if it is cleared, the pending bit is set on the falling edge of the input pin. Each source can be individually masked through the corresponding control bit IMA0,..,IMD1 (EIMR.7,..,0). See Figure 51.

Figure 50. Priority Level Examples

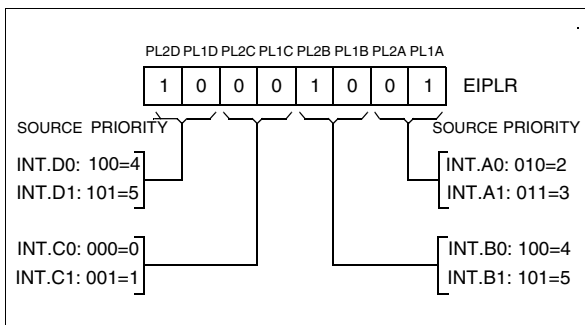

The priority level of the external interrupt sources can be programmed among the eight priority levels with the control register EIPLR (R245). The priority level of each pair is software defined using the bits PRL2,PRL1. For each pair, the even channel (A0,B0,C0,D0) of the group has the even priority level and the odd channel (A1,B1,C1,D1) has the odd (lower) priority level.

Figure 50 shows an example of priority levels.

Figure 51 and Table 20 give an overview of the external interrupts and vectors.

Table 20. Multiplexed Interrupt Sources

Channel	Internal Interrupt Source	External Interrupt
INTA0	Timer/Watchdog	INT0
INTA1	Standard Timer	INT1
INTB0	Extended Function Timer 0	INT2
INTB1	Extended Function Timer 1	INT3
INTC0	E ³ ™/Flash	INT4
INTC1	SPI Interrupt	INT5
INTD0	RCCU	INT6
INTD1	Wake-up Management Unit	

- The source of INTA0 can be selected between the external pin INT0 or the Timer/Watchdog peripheral using the IA0S bit in the EIVR register (R246 Page 0).
- The source of INTA1 can be selected between the external pin INT1 or the Standard Timer using the INTS bit in the STC register (R232 Page 11).
- The source of INTB0 can be selected between the external pin INT2 or the on-chip Extended Function Timer 0 using the EFTIS bit in the CR3 register (R255 Page 28).
- The source of INTB1 can be selected between external pin INT3 or the on-chip Extended Function Timer 1 using the EFTIS bit in the CR3 register (R255 Page 29).
- The source of INTC0 can be selected between external pin INT4 or the On-chip E³™/Flash Memory using bit FEIEN in the ECR register (Address 224001h).
- The source of INTC1 can be selected between external pin INT5 or the on-chip SPI using the SPIS bit in the SPCR0 register (R241 Page 7).
- The source of INTD0 can be selected between external pin INT6 or the Reset and Clock Unit RCCU using the INT_SEL bit in the CLKCTL register (R240 Page 55).
- The source of INTD1 can be selected between the NMI pin and the WUIMU Wakeup/Interrupt Lines using the ID1S bit in the WUCRTL register (R248 Page 9).

Warning: When using external interrupt channels shared by both external interrupts and peripherals, special care must be taken to configure control registers both for peripheral and interrupts.

EXTERNAL INTERRUPTS (Cont'd)

Figure 51. External Interrupt Control Bits and Vectors

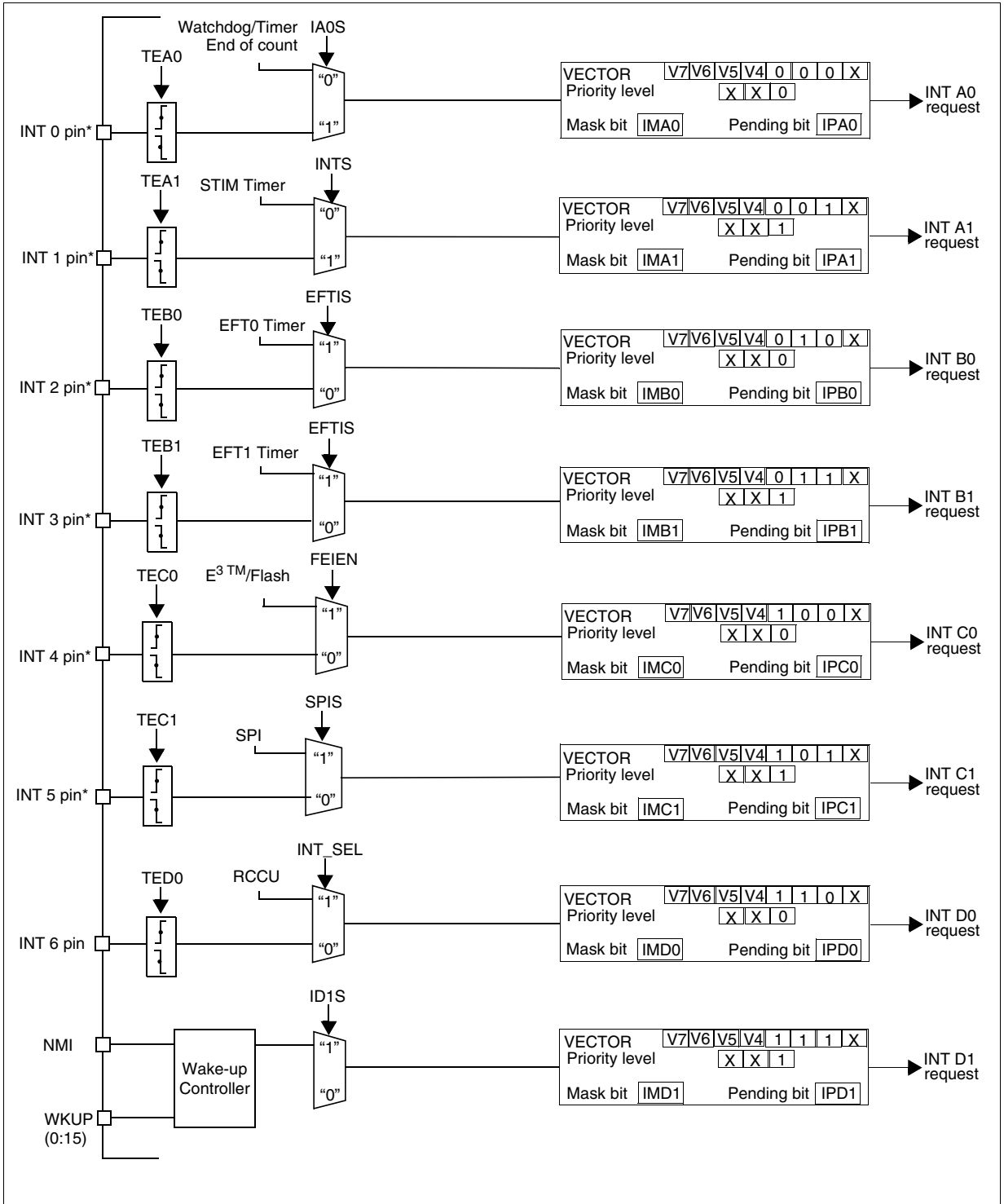

* Only four interrupt pins are available. Refer to Table 19 for I/O pin mapping.

5.7 STANDARD INTERRUPTS (CAN AND SCI-A)

The two on-chip CAN peripherals generate 4 interrupt sources each. The SCI-A interrupts are mapped on a single interrupt channel. The mapping is shown in the following table.

Table 21. Interrupt Channel Assignment

Interrupt Pairs	Interrupt Source
INTE0 INTE1	CAN0_RX0 CAN0_RX1
INTF0 INTF1	CAN0_TX CAN0_SCE
INTG0 INTG1	CAN1_RX0 CAN1_RX1
INTH0 INTH1	CAN1_TX CAN1_SCE
INTI0 INTI1	SCI-A Reserved

5.7.1 Functional Description

The SIPRL and SIPRH registers contain the interrupt pending bits of the interrupt sources. The pending bits are set by hardware on occurrence of a rising edge event. The pending bits are reset by hardware when the interrupt is acknowledged.

The SIMRL and SIMRH registers are used to mask the interrupt requests coming from the interrupt sources. Resetting the bits of these registers prevents the interrupt requests being sent to the ST9 core.

The SITRL and SITRH registers are used to select the edge sensitivity of the interrupt channel (rising or falling edge). As the SCI-A and CAN interrupt events are rising edge events, all bits in the SITRL register and ITEI0 bit in SITRH register must be set to 1.

The priority level of the interrupt channels can be programmed to one of eight priority levels using the SIPLRL and SIPLRH control registers.

The two MSBs of the priority level are user programmable. For each interrupt group, the even channels (E0, F0, G0, H0, I0) have an even priority level (LSB of priority level is zero) and the odd channels (E1, F1, G1, H1) have an odd priority level (the LSB of priority level is one). See Figure 52.

Figure 52. Priority Level Examples

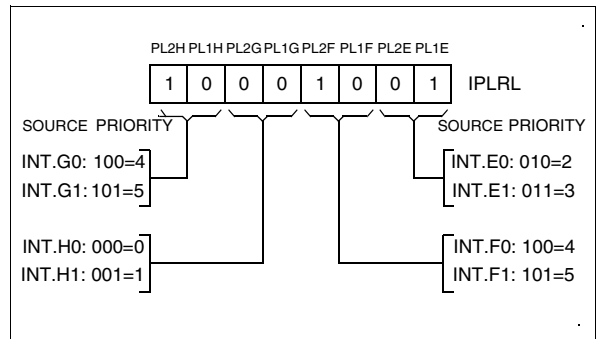

All interrupt channels share a single interrupt vector register (SIVR). Bits 1 to 4 of the SIVR register change according to the interrupt channel which has the highest priority pending interrupt request. If more than one interrupt channel has pending interrupt requests with the same priority, then an internal daisy chain decides the interrupt channel that will be served. INTE0 is first in the internal daisy chain and INTI0 is last.

An overrun flag is associated with each interrupt channel. If a new interrupt request comes before the earlier interrupt request is acknowledged then the corresponding overrun flag is set.

Figure 53. Standard Interrupt (Channels E to I) Control Bits and Vectors

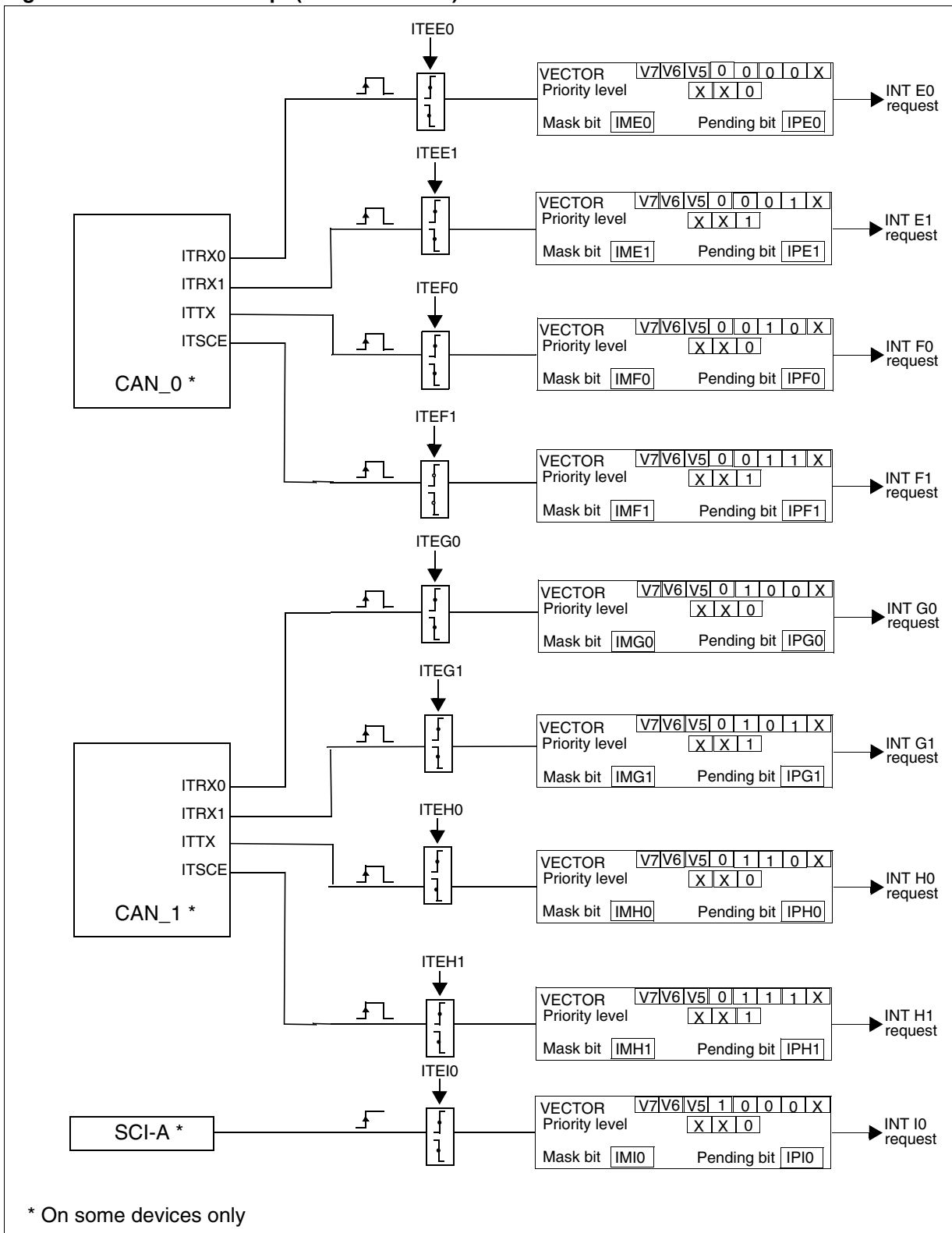

5.7.2 IMPORTANT NOTE ON STANDARD INTERRUPTS

Refer to [Section 13.4 on page 413](#).

5.8 TOP LEVEL INTERRUPT

The Top Level Interrupt channel can be assigned either to the external pin NMI or to the Timer/Watchdog according to the status of the control bit EIVR.TLIS (R246.2, Page 0). If this bit is high (the reset condition) the source is the external pin NMI. If it is low, the source is the Timer/ Watchdog End Of Count. When the source is the NMI external pin, the control bit EIVR.TLTEV (R246.3; Page 0) selects between the rising (if set) or falling (if reset) edge generating the interrupt request. When the selected event occurs, the CICR.TLIP bit (R230.6) is set. Depending on the mask situation, a Top Level Interrupt request may be generated. Two kinds of masks are available, a Maskable mask and a Non-Maskable mask. The first mask is the CICR.TLI bit (R230.5): it can be set or cleared to enable or disable respectively the Top Level Interrupt request. If it is enabled, the global Enable Interrupt bit, CICR.IEN (R230.4) must also be enabled in order to allow a Top Level Request.

The second mask NICR.TLNM (R247.7) is a set-only mask. Once set, it enables the Top Level Interrupt request independently of the value of CICR.IEN and it cannot be cleared by the program. Only the processor RESET cycle can clear this bit. This does not prevent the user from ignoring some sources due to a change in TLIS.

The Top Level Interrupt Service Routine cannot be interrupted by any other interrupt or DMA request, in any arbitration mode, not even by a subsequent Top Level Interrupt request.

Warning. The interrupt machine cycle of the Top Level Interrupt does not clear the CICR.IEN bit, and the corresponding `iret` does not set it. Furthermore the TLI never modifies the CPL bits and the NICR register.

5.9 DEDICATED ON-CHIP PERIPHERAL INTERRUPTS

Some of the on-chip peripherals have their own specific interrupt unit containing one or more interrupt channels, or DMA channels. Please refer to the specific peripheral chapter for the description of its interrupt features and control registers.

The on-chip peripheral interrupts are controlled by the following bits:

- **Interrupt Pending bit (IP).** Set by hardware when the Trigger Event occurs. Can be set/cleared by software to generate/cancel pending interrupts and give the status for Interrupt polling.
- **Interrupt Mask bit (IM).** If IM = “0”, no interrupt request is generated. If IM = “1” an interrupt request is generated whenever IP = “1” and CICR.IEN = “1”.
- **Priority Level (PRL, 3 bits).** These bits define the current priority level, PRL=0: the highest priority, PRL=7: the lowest priority (the interrupt cannot be acknowledged)
- **Interrupt Vector Register (IVR, up to 7 bits).** The IVR points to the vector table which itself contains the interrupt routine start address.

Figure 54. Top Level Interrupt Structure

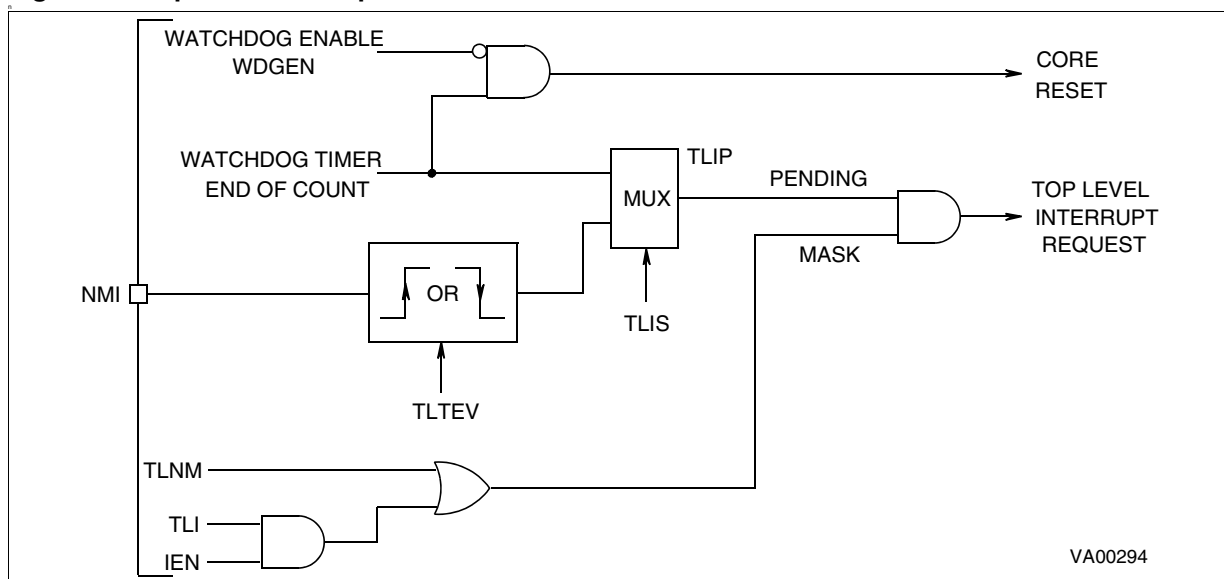

5.10 INTERRUPT RESPONSE TIME

The interrupt arbitration protocol functions completely asynchronously from instruction flow and requires 5 clock cycles. One more CPUCLK cycle is required when an interrupt is acknowledged. Requests are sampled every 5 CPUCLK cycles.

If the interrupt request comes from an external pin, the trigger event must occur a minimum of one INTCLK cycle before the sampling time.

When an arbitration results in an interrupt request being generated, the interrupt logic checks if the current instruction (which could be at any stage of execution) can be safely aborted; if this is the case, instruction execution is terminated immediately and the interrupt request is serviced; if not, the CPU waits until the current instruction is terminated and then services the request. Instruction execution can normally be aborted provided no write operation has been performed.

For an interrupt deriving from an external interrupt channel, the response time between a user event and the start of the interrupt service routine can range from a minimum of 26 clock cycles to a maximum of 55 clock cycles (DIV instruction), 53 clock

cycles (DIVWS and MUL instructions) or 49 for other instructions.

For a non-maskable Top Level interrupt, the response time between a user event and the start of the interrupt service routine can range from a minimum of 22 clock cycles to a maximum of 51 clock cycles (DIV instruction), 49 clock cycles (DIVWS and MUL instructions) or 45 for other instructions.

In order to guarantee edge detection, input signals must be kept low/high for a minimum of one INTCLK cycle.

An interrupt machine cycle requires a basic 18 internal clock cycles (CPUCLK), to which must be added a further 2 clock cycles if the stack is in the Register File. 2 more clock cycles must further be added if the CSR is pushed (ENCSR =1).

The interrupt machine cycle duration forms part of the two examples of interrupt response time previously quoted; it includes the time required to push values on the stack, as well as interrupt vector handling.

In Wait for Interrupt mode, a further cycle is required as wake-up delay.

5.11 INTERRUPT REGISTERS

CENTRAL INTERRUPT CONTROL REGISTER (CICR)

R230 - Read/Write

Register Group: System

Reset value: 1000 0111 (87h)

7							0
GCEN	TLIP	TLI	IEN	IAM	CPL2	CPL1	CPL0

Bit 7 = **GCEN**: *Global Counter Enable*.
 This bit enables the 16-bit Multifunction Timer peripheral.
 0: MFT disabled
 1: MFT enabled

Bit 6 = **TLIP**: *Top Level Interrupt Pending*.
 This bit is set by hardware when Top Level Interrupt (TLI) trigger event occurs. It is cleared by hardware when a TLI is acknowledged. It can also be set by software to implement a software TLI.
 0: No TLI pending
 1: TLI pending

Bit 5 = **TLI**: *Top Level Interrupt*.
 This bit is set and cleared by software.
 0: A Top Level Interrupt is generated when TLIP is set, only if TLNM=1 in the NICR register (independently of the value of the IEN bit).
 1: A Top Level Interrupt request is generated when IEN=1 and the TLIP bit are set.

Bit 4 = **IEN**: *Interrupt Enable*.
 This bit is cleared by the interrupt machine cycle (except for a TLI).
 It is set by the `iret` instruction (except for a return from TLI).
 It is set by the `EI` instruction.
 It is cleared by the `DI` instruction.
 0: Maskable interrupts disabled
 1: Maskable Interrupts enabled

Note: The IEN bit can also be changed by software using any instruction that operates on register CICR, however in this case, take care to avoid spurious interrupts, since IEN cannot be cleared in the middle of an interrupt arbitration. Only modify

the IEN bit when interrupts are disabled or when no peripheral can generate interrupts. For example, if the state of IEN is not known in advance, and its value must be restored from a previous push of CICR on the stack, use the sequence `DI; POP CICR` to make sure that no interrupts are being arbitrated when CICR is modified.

Bit 3 = **IAM**: *Interrupt Arbitration Mode*.
 This bit is set and cleared by software.
 0: Concurrent Mode
 1: Nested Mode

Bits 2:0 = **CPL[2:0]**: *Current Priority Level*.
 These bits define the Current Priority Level. CPL=0 is the highest priority. CPL=7 is the lowest priority. These bits may be modified directly by the interrupt hardware when Nested Interrupt Mode is used.

EXTERNAL INTERRUPT TRIGGER REGISTER (EITR)

R242 - Read/Write

Register Page: 0

Reset value: 0000 0000 (00h)

7							0
TED1	TED0	TEC1	TEC0	TEB1	TEB0	TEA1	TEA0

Bit 7 = **TED1**: *INTD1 Trigger Event*
 Bit 6 = **TED0**: *INTD0 Trigger Event*
 Bit 5 = **TEC1**: *INTC1 Trigger Event*
 Bit 4 = **TEC0**: *INTC0 Trigger Event*
 Bit 3 = **TEB1**: *INTB1 Trigger Event*
 Bit 2 = **TEB0**: *INTB0 Trigger Event*
 Bit 1 = **TEA1**: *INTA1 Trigger Event*
 Bit 0 = **TEA0**: *INTA0 Trigger Event*

These bits are set and cleared by software.
 0: Select falling edge as interrupt trigger event
 1: Select rising edge as interrupt trigger event

INTERRUPT REGISTERS (Cont'd)

EXTERNAL INTERRUPT PENDING REGISTER (EIPR)

R243 - Read/Write

Register Page: 0

Reset value: 0000 0000 (00h)

7							0
IPD1	IPD0	IPC1	IPC0	IPB1	IPB0	IPA1	IPA0

Bit 7 = **IPD1**: *INTD1 Interrupt Pending bit*

Bit 6 = **IPD0**: *INTD0 Interrupt Pending bit*

Bit 5 = **IPC1**: *INTC1 Interrupt Pending bit*

Bit 4 = **IPC0**: *INTC0 Interrupt Pending bit*

Bit 3 = **IPB1**: *INTB1 Interrupt Pending bit*

Bit 2 = **IPB0**: *INTB0 Interrupt Pending bit*

Bit 1 = **IPA1**: *INTA1 Interrupt Pending bit*

Bit 0 = **IPA0**: *INTA0 Interrupt Pending bit*

These bits are set by hardware on occurrence of a trigger event (as specified in the EITR register) and are cleared by hardware on interrupt acknowledge. They can also be set by software to implement a software interrupt.

0: No interrupt pending

1: Interrupt pending

EXTERNAL INTERRUPT MASK-BIT REGISTER (EIMR)

R244 - Read/Write

Register Page: 0

Reset value: 0000 0000 (00h)

7							0
IMD1	IMD0	IMC1	IMC0	IMB1	IMB0	IMA1	IMA0

Bit 7 = **IMD1**: *INTD1 Interrupt Mask*

Bit 6 = **IMD0**: *INTD0 Interrupt Mask*

Bit 5 = **IMC1**: *INTC1 Interrupt Mask*

Bit 4 = **IMC0**: *INTC0 Interrupt Mask*

Bit 3 = **IMB1**: *INTB1 Interrupt Mask*

Bit 2 = **IMB0**: *INTB0 Interrupt Mask*

Bit 1 = **IMA1**: *INTA1 Interrupt Mask*

Bit 0 = **IMA0**: *INTA0 Interrupt Mask*

These bits are set and cleared by software.

0: Interrupt masked

1: Interrupt not masked (an interrupt is generated if the IPxx and IEN bits = 1)

EXTERNAL INTERRUPT PRIORITY LEVEL REGISTER (EIPLR)

R245 - Read/Write

Register Page: 0

Reset value: 1111 1111 (FFh)

7							0
PL2D	PL1D	PL2C	PL1C	PL2B	PL1B	PL2A	PL1A

Bits 7:6 = **PL2D, PL1D**: *INTD0, D1 Priority Level.*

Bits 5:4 = **PL2C, PL1C**: *INTC0, C1 Priority Level.*

Bits 3:2 = **PL2B, PL1B**: *INTB0, B1 Priority Level.*

Bits 1:0 = **PL2A, PL1A**: *INTA0, A1 Priority Level.*

These bits are set and cleared by software.

The priority is a three-bit value. The LSB is fixed by hardware at 0 for Channels A0, B0, C0 and D0 and at 1 for Channels A1, B1, C1 and D1.

PL2x	PL1x	Hardware bit	Priority
0	0	0 1	0 (Highest) 1
0	1	0 1	2 3
1	0	0 1	4 5
1	1	0 1	6 7 (Lowest)

INTERRUPT REGISTERS (Cont'd)

EXTERNAL INTERRUPT VECTOR REGISTER (EIVR)

R246 - Read/Write

Register Page: 0

Reset value: xxxx 0110 (x6h)

7							0
V7	V6	V5	V4	TLTEV	TLIS	IAOS	EWEN

Bits 7:4 = **V[7:4]**: *Most significant nibble of External Interrupt Vector.*

These bits are not initialized by reset. For a representation of how the full vector is generated from V[7:4] and the selected external interrupt channel, refer to [Figure 51](#).

Bit 3 = **TLTEV**: *Top Level Trigger Event bit.*

This bit is set and cleared by software.

- 0: Select falling edge as NMI trigger event
- 1: Select rising edge as NMI trigger event

Bit 2 = **TLIS**: *Top Level Input Selection.*

This bit is set and cleared by software.

- 0: Watchdog End of Count is TL interrupt source (the IAOS bit must be set in this case)
- 1: NMI is TL interrupt source

Bit 1 = **IAOS**: *Interrupt Channel A0 Selection.*

This bit is set and cleared by software.

- 0: Watchdog End of Count is INTA0 source (the TLIS bit must be set in this case)
- 1: External Interrupt pin is INTA0 source

Bit 0 = **EWEN**: *External Wait Enable.*

This bit is set and cleared by software.

0: WAITN pin disabled

1: WAITN pin enabled (to stretch the external memory access cycle).

Note: For more details on Wait mode refer to the section describing the WAITN pin in the External Memory Chapter.

NESTED INTERRUPT CONTROL (NICR)

R247 - Read/Write

Register Page: 0

Reset value: 0000 0000 (00h)

7							0
TLNM	HL6	HL5	HL4	HL3	HL2	HL1	HL0

Bit 7 = **TLNM**: *Top Level Not Maskable.*

This bit is set by software and cleared only by a hardware reset.

- 0: Top Level Interrupt Maskable. A top level request is generated if the IEN, TLI and TLIP bits =1
- 1: Top Level Interrupt Not Maskable. A top level request is generated if the TLIP bit =1

Bits 6:0 = **HL[6:0]**: *Hold Level x*

These bits are set by hardware when, in Nested Mode, an interrupt service routine at level x is interrupted from a request with higher priority (other than the Top Level interrupt request). They are cleared by hardware at the `iret` execution when the routine at level x is recovered.

INTERRUPT REGISTERS (Cont'd)

INTERRUPT MASK REGISTER HIGH (SIMRH)

R245 - Read/Write
 Register Page: 60
 Reset value: 0000 0000 (00h)



Bits 7:1 = Reserved.

Bit 0 = **IMIO Channel I Mask bit**

The IMIO bit is set and cleared by software to enable or disable interrupts on channel I0 .

0: Interrupt masked

1: An interrupt is generated if the IPI0 bit is set in the SIPRH register.

INTERRUPT MASK REGISTER LOW (SIMRL)

R246 - Read/Write
 Register Page: 60
 Reset value: 0000 0000 (00h)

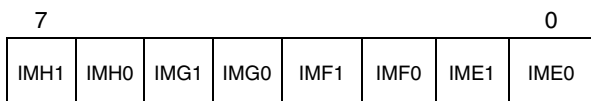

Bits 7:0 = **IMxx Channel E to H Mask bits**

The IMxx bits are set and cleared by software to enable or disable on channel xx interrupts.

0: Interrupt masked

1: An interrupt is generated if the corresponding IPxx bit is set in the SIPRL register.

INTERRUPT TRIGGER EVENT REGISTER HIGH (SITRH)

R247 - Read/Write
 Register Page: 60
 Reset value: 0000 0000 (00h)

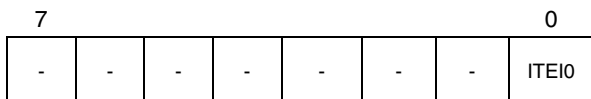

Bits 7:1 = Reserved.

Bit 0 = **ITEI0 Channel I0 Trigger Event**

This bit is set and cleared by software to define the polarity of the channel I0 trigger event

0: The I0 pending bit will be set on the falling edge of the interrupt line

1: The I0 pending bit will be set on the rising edge of the interrupt line

Note: The ITEI0 bit must be set to enable the SCI-A interrupt as the SCI-A interrupt event is a rising edge event.

INTERRUPT TRIGGER EVENT REGISTER LOW (SITRL)

R248 - Read/Write
 Register Page: 60
 Reset value: 0000 0000 (00h)

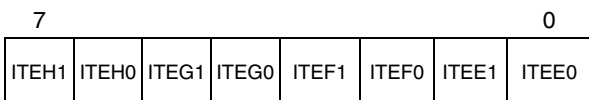

Bits 7:0 = **ITExx Channel E to H Trigger Event**

The ITExx bits are set and cleared by software to define the polarity of the channel xx trigger event

0: The corresponding pending bit will be set on the falling edge of the interrupt line

1: The corresponding pending bit will be set on the rising edge of the interrupt line

Note: The ITExx bits must be set to enable the CAN interrupts as the CAN interrupt events are rising edge events.

Note: If either a rising or a falling edge occurs on the interrupt lines during a write access to the ITER register, the pending bit will not be set.

INTERRUPT PENDING REGISTER HIGH (SIPRH)

R249 - Read/Write
 Register Page: 60
 Reset value: 0000 0000 (00h)

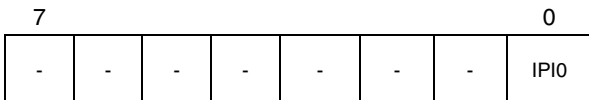

Bits 7:1 = Reserved.

Bit 0 = **IPI0 Channel I0 Pending bit**

The IPI0 bit is set by hardware on occurrence of the trigger event. (as specified in the ITR register) and is cleared by hardware on interrupt acknowledge.

0 : No interrupt pending

1 : Interrupt pending

INTERRUPT REGISTERS (Cont'd)

INTERRUPT PENDING REGISTER LOW (SIPRL)

R250 - Read/Write

Register Page: 60

Reset value: 0000 0000 (00h)

7							0
IPH1	IPH0	IPG1	IPG0	IPF1	IPF0	IPE1	IPE0

Bits 7:0 = **IPxx Channel E-H Pending bits**

The IPxx bits are set by hardware on occurrence of the trigger event. (as specified in the ITR register) and are cleared by hardware on interrupt acknowledgement.

0 : No interrupt pending

1 : Interrupt pending

Note: IPR bits may be set by the user to implement a software interrupt.

STANDARD INTERRUPT VECTOR REGISTER (SIVR)

R251 - Read/Write

Register Page: 60

Reset value: xxx1 1110 (xE)

7							0
V7	V6	V5	W3	W2	W1	W0	0

Bits 7:5 = **V[7:5] MSBs of Channel E to L interrupt vector address**

These bits are not initialized by reset. For a representation of how the full vector is generated from V[7:5], refer to [Figure 53](#).

Bits 4:1 = **W[3:0] Arbitration Winner Bits**

These bits are set and cleared by hardware depending upon the channel which emerges as a winner as shown in the following table.

Interrupt Channel pair	W[3:0]
INTE0	0000
INTE1	0001
INTF0	0010
INTF1	0011
INTG0	0100
INTG1	0101
INTH0	0110
INTH1	0111
INTI0	1000

At the start of interrupt/DMA arbitration (IC0 = 0) the W[3:0] bits are latched. They remain stable through the entire arbitration cycle. Even if a interrupt of higher priority comes after the start of int/DMA arbitration, the SIVR register is not updated. This new request will be taken into account in the next arbitration cycle.

Bit 0 = Reserved, fixed by hardware to 0.

INTERRUPT PRIORITY LEVEL REGISTER HIGH (SIPLRH)

R252 - Read/Write

Register Page: Page 60

Reset Value : 1111 1111

7							0
-	-	-	-	-	-	PL2I	PL1I

Bits 1:0 = **PL2I, PL1I: INTI0, I1 Priority Level.**

These bits are set and cleared by software.

The priority is a three-bit value. The LSB is fixed by hardware at 0 for even channels and at 1 for odd channels

INTERRUPT REGISTERS (Cont'd)

INTERRUPT PRIORITY LEVEL REGISTER LOW (SIPRL)

R253 - Read/Write
 Register Page: Page 60
 Reset Value : 1111 1111

7						0	
PL2H	PL1H	PL2G	PL1G	PL2F	PL1F	PL2E	PL1E

Bits 7:6 = **PL2H, PL1H**: *INTH0, H1 Priority Level.*
 Bits 5:4 = **PL2G, PL1G**: *INTG0, G1 Priority Level.*
 Bits 3:2 = **PL2F, PL1F**: *INTF0, F1 Priority Level.*
 Bits 1:0 = **PL2E, PL1E**: *INTE0, E1 Priority Level.*

These bits are set and cleared by software.
 The priority is a three-bit value. The LSB is fixed by hardware at 0 for even channels and at 1 for odd channels

Table 22. PL Bit Assignment

Interrupt Channel Pair	3-bit Priority Level		
INTH0	PL2H	PL1H	0
INTH1	PL2H	PL1H	1
INTG0	PL2G	PL1G	0
INTG1	PL2G	PL1G	1
INTF0	PL2F	PL1F	0
INTF1	PL2F	PL1F	1
INTE0	PL2E	PL1E	0
INTE1	PL2E	PL1E	1

Table 23. PL bit Meaning

PL2x	PL1x	Hardware bit	Priority
0	0	0	0 (Highest)
		1	1
0	1	0	2
		1	3
1	0	0	4
		1	5
1	1	0	6
		1	7 (Lowest)

Interrupt Channel Pair	Priority Level		
INTE0	PL2E	PL1E	0
INTE1	PL2E	PL1E	1
INTF0	PL2F	PL1F	0
INTF1	PL2F	PL1F	1
INTG0	PL2G	PL1G	0
INTG1	PL2G	PL1G	1
INTH0	PL2H	PL1H	0
INTH1	PL2H	PL1H	1

INTERRUPT FLAG REGISTER HIGH (SFLAGRH)

R254 - Read Only
 Register Page: 60
 Reset Value : 0000 0000

7							0
-	-	-	-	-	-	-	OUIF0

Bit 0 = **OUIF0** : Overrun flag for INTI0
 This bit is set and cleared by hardware. It indicates if more than one interrupt event occurred on INTI0 before the IPI0 bit in the SIPRH register has been cleared.
 0 : No overrun
 1 : Overrun has occurred on INTI0

INTERRUPT FLAG REGISTER LOW (SFLAGRL)

R255 - Read Only
 Register Page: 60
 Reset Value : 0000 0000

7							0
OUIFH1	OUIFH0	OUIFG1	OUIFG0	OUIFF1	OUIFF0	OUIFE1	OUIFE0

Bits 7:0 = **OUIFxx** : Overrun flag for channel xx
 These bits are set and cleared by hardware. They indicate if more than one interrupt event occurs on the associated channel before the pending bit in the SIPRL register has been cleared.
 0 : No overrun
 1 : Overrun has occurred on channel xx

INTERRUPT REGISTERS (Cont'd)

Table 25. Standard Interrupt Channel Register map (Page 60)

Address	Register Name	7	6	5	4	3	2	1	0
R245	SIMRH Reset value	0	0	0	0	0	0	0	IMIO 0
R246	SIMRL Reset value	IMH1 0	IMH0 0	IMG1 0	IMG0 0	IMF1 0	IMF0 0	IME1 0	IME0 0
R247	SITRH Reset value	0	0	0	0	0	0	0	ITEI0 0
R248	SITRL Reset value	ITEH1 0	ITEH0 0	ITEG1 0	ITEG0 0	ITEF1 0	ITEF0 0	ITEE1 0	ITEE0 0
R249	SIPRH Reset value	0	0	0	0	0	0	0	IPI0 0
R250	SIPRL Reset value	IPH1 0	IPH0 0	IPG1 0	IPG0 0	IPF1 0	IPF0 0	IPE1 0	IPE0 0
R251	SIVR Reset value	V2 x	V1 x	V0 x	W3 1	W2 1	W1 1	W0 1	0 0
R252	SIPLRH Reset value	0	0	0	0	0	0	PL2I 1	PL1I 1
R253	SIPLRL Reset value	PL2H 1	PL1H 1	PL2G 1	PL1G 1	PL2F 1	PL1F 1	PL2E 1	PL1E 1
R254	SFLAGRH Reset value	0	0	0	0	0	0	0	OUF0 0
R255	SFLAGRL Reset value	OUF7 0	OUF6 0	OUF5 0	OUF4 0	OUF3 0	OUF2 0	OUF1 0	OUF0 0

5.12 WAKE-UP / INTERRUPT LINES MANAGEMENT UNIT (WUIMU)

5.12.1 Introduction

The Wake-up/Interrupt Management Unit extends the number of external interrupt lines from 8 to 23 (depending on the number of external interrupt lines mapped on external pins of the device).

The 16 additional external Wake-up/interrupt pins can be programmed as external interrupt lines or as wake-up lines, able to exit the microcontroller from low power mode (STOP mode) (see [Figure 55](#)).

5.12.2 Main Features

- Supports up to 16 additional external wake-up or interrupt lines
- Wake-Up lines can be used to wake-up the ST9 from STOP mode.
- Programmable selection of wake-up or interrupt
- Programmable wake-up trigger edge polarity
- All Wake-Up Lines maskable

Note: The number of available pins is device dependent. Refer to the device pinout description.

Figure 55. Wake-Up Lines / Interrupt Management Unit Block Diagram

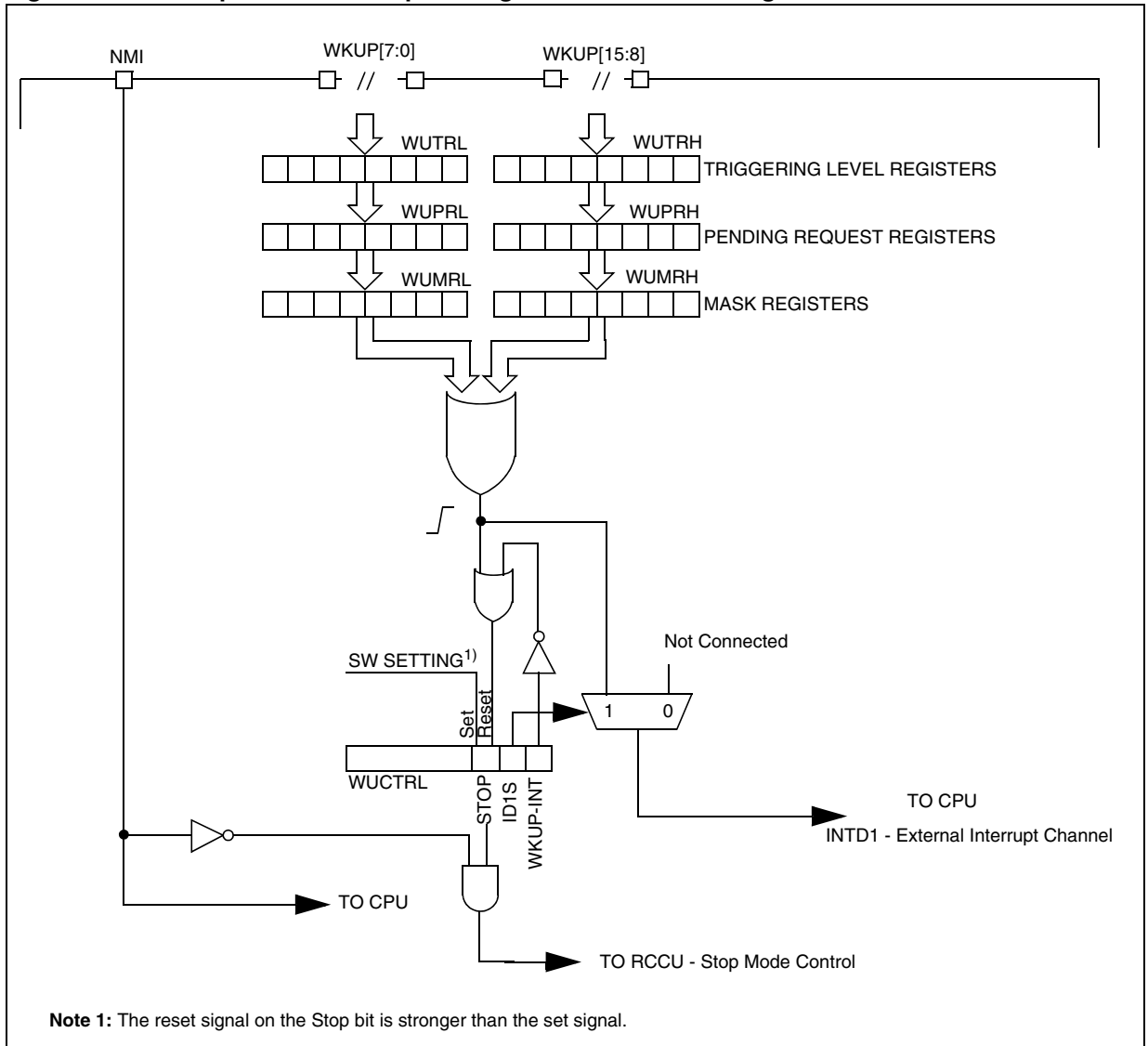

WAKE-UP / INTERRUPT LINES MANAGEMENT UNIT (Cont'd)**5.12.3 Functional Description****5.12.3.1 Interrupt Mode**

To configure the 16 wake-up lines as interrupt sources, use the following procedure:

1. Configure the mask bits of the 16 wake-up lines (WUMRL, WUMRH)
2. Configure the triggering edge registers of the wake-up lines (WUTRL, WUTRH)
3. Set bit 7 of EIMR (R244 Page 0) and EITR (R242 Page 0) registers of the CPU: so an interrupt coming from one of the 16 lines can be correctly acknowledged
4. Reset the WKUP-INT bit in the WUCTRL register to disable Wake-up Mode
5. Set the ID1S bit in the WUCTRL register to enable the 16 wake-up lines as external interrupt source lines.

5.12.3.2 Wake-up Mode Selection

To configure the 16 lines as wake-up sources, use the following procedure:

1. Configure the mask bits of the 16 wake-up lines (WUMRL, WUMRH).
2. Configure the triggering edge registers of the wake-up lines (WUTRL, WUTRH).
3. Set, as for Interrupt Mode selection, bit 7 of EIMR and EITR registers only if an interrupt routine is to be executed after a wake-up event. Otherwise, if the wake-up event only restarts the execution of the code from where it was stopped, the INTD1 interrupt channel must be masked.
4. Since the RCCU can generate an interrupt request when exiting from STOP mode, take care to mask it even if the wake-up event is only to restart code execution.
5. Set the WKUP-INT bit in the WUCTRL register to select Wake-up Mode
6. Set the ID1S bit in the WUCTRL register to enable the 16 wake-up lines as external interrupt source lines. This is not mandatory if the

wake-up event does not require an interrupt response.

7. Write the sequence 1,0,1 to the STOP bit of the WUCTRL register with three consecutive write operations. This is the STOP bit setting sequence.

To detect if STOP Mode was entered or not, immediately after the STOP bit setting sequence, poll the RCCU EX_STP bit (R242.7, Page 55) and the STOP bit itself.

5.12.3.3 STOP Mode Entry Conditions

Assuming the ST9 is in Run mode: during the STOP bit setting sequence the following cases may occur:

Case 1: NMI = 0, wrong STOP bit setting sequence

This can happen if an Interrupt/DMA request is acknowledged during the STOP bit setting sequence. In this case polling the STOP and EX_STP bits will give:

STOP = 0, EX_STP = 0

This means that the ST9 did not enter STOP mode due to a bad STOP bit setting sequence: the user must retry the sequence.

Case 2: NMI = 0, correct STOP bit setting sequence

In this case the ST9 enters STOP mode. There are two ways to exit STOP mode:

1. A wake-up interrupt (not an NMI interrupt) is acknowledged. That implies:

STOP = 0, EX_STP = 1

This means that the ST9 entered and exited STOP mode due to an external wake-up line event.

2. A NMI rising edge woke up the ST9. This implies:

STOP = 1, EX_STP = 1

This means that the ST9 entered and exited STOP mode due to an NMI (rising edge) event. The user should clear the STOP bit via software.

WAKE-UP / INTERRUPT LINES MANAGEMENT UNIT (Cont'd)**Case 3: NMI = 1 (NMI kept high during the 3rd write instruction of the sequence), bad STOP bit setting sequence**

The result is the same as Case 1:

STOP = 0, EX_STP = 0

This means that the ST9 did not enter STOP mode due to a bad STOP bit setting sequence: the user must retry the sequence.

Case 4: NMI = 1 (NMI kept high during the 3rd write instruction of the sequence), correct STOP bit setting sequence

In this case:

STOP = 1, EX_STP = 0

This means that the ST9 did not enter STOP mode due to NMI being kept high. The user should clear the STOP bit via software.

Note: If NMI goes to 0 before resetting the STOP bit, the ST9 will not enter STOP mode.

Case 5: A rising edge on the NMI pin occurs during the STOP bit setting sequence.

The NMI interrupt will be acknowledged and the ST9 will not enter STOP mode. This implies:

STOP = 0, EX_STP = 0

This means that the ST9 did not enter STOP mode due to an NMI interrupt serviced during the STOP bit setting sequence. At the end of NMI routine, the user must re-enter the sequence: if NMI is still high at the end of the sequence, the ST9 can not enter STOP mode (See "NMI Pin Management" on page 116.).

Case 6: A wake-up event on the external wake-up lines occurs during the STOP bit setting sequence

There are two possible cases:

1. Interrupt requests to the CPU are disabled: in this case the ST9 will not enter STOP mode, no interrupt service routine will be executed and the program execution continues from the instruction following the STOP bit setting sequence. The status of STOP and EX_STP bits will be again:

STOP = 0, EX_STP = 0

The application can determine why the ST9 did not enter STOP mode by polling the pending bits of the external lines (at least one must be at 1).

2. Interrupt requests to CPU are enabled: in this case the ST9 will not enter STOP mode and the interrupt service routine will be executed. The status of STOP and EX_STP bits will be again:

STOP = 0, EX_STP = 0

The interrupt service routine can determine why the ST9 did not enter STOP mode by polling the pending bits of the external lines (at least one must be at 1).

If the MCU really exits from STOP Mode, the RCCU EX_STP bit is still set and must be reset by software. Otherwise, if NMI was high or an Interrupt/DMA request was acknowledged during the STOP bit setting sequence, the RCCU EX_STP bit is reset. This means that the MCU has filtered the STOP Mode entry request.

The WKUP-INT bit can be used by an interrupt routine to detect and to distinguish events coming from Interrupt Mode or from Wake-up Mode, allowing the code to execute different procedures.

To exit STOP mode, it is sufficient that one of the 16 wake-up lines (not masked) generates an event: the clock restarts after the delay needed for the oscillator to restart.

The same effect is obtained when a rising edge is detected on the NMI pin, which works as a 17th wake-up line.

Note: After exiting from STOP Mode, the software can successfully reset the pending bits (edge sensitive), even though the corresponding wake-up line is still active (high or low, depending on the Trigger Event register programming); the user must poll the external pin status to detect and distinguish a short event from a long one (for example keyboard input with keystrokes of varying length).

WAKE-UP / INTERRUPT LINES MANAGEMENT UNIT (Cont'd)

5.12.3.4 NMI Pin Management

On the CPU side, if TLTEV=1 (Top Level Trigger Event, bit 3 of register R246, page 0) then a rising edge on the NMI pin will set the TLIP bit (Top Level Interrupt Pending bit, R230.6). At this point an interrupt request to the CPU is given either if TLNM=1 (Top Level Not Maskable bit, R247.7 - once set it can only be cleared by RESET) or if TLI=1 and IEN=1 (bits R230.5, R230.4).

Assuming that the application uses a non-maskable Top Level Interrupt (TLNM=1): in this case, whenever a rising edge occurs on the NMI pin, the related service routine will be executed. To service further Top Level Interrupt Requests, it is necessary to generate a new rising edge on the external NMI pin.

The following summarizes some typical cases:

- If the ST9 is in STOP mode and a rising edge on the NMI pin occurs, the ST9 will exit STOP mode and the NMI service routine will be executed.
- If the ST9 is in Run mode and a rising edge occurs on the NMI pin: the NMI service routine is executed and then the ST9 restarts the execution of the main program. **Now, suppose that the user wants to enter STOP mode with NMI still at 1. The ST9 will not enter STOP mode and it will not execute an NMI routine because there were no transitions on the external NMI line.**
- If the ST9 is in run mode and a rising edge on NMI pin occurs during the STOP bit setting sequence: the NMI interrupt will be acknowledged and the ST9 will not enter STOP mode. At the end of the NMI routine, the user must re-enter the sequence: if NMI is still high at the end of the sequence, the ST9 can not enter STOP mode (see previous case).
- If the ST9 is in run mode and the NMI pin is high: if NMI is forced low just before the third write instruction of the STOP bit setting sequence then the ST9 will enter STOP mode.

WAKE-UP / INTERRUPT LINES MANAGEMENT UNIT (Cont'd)**5.12.4 Programming Considerations**

The following paragraphs give some guidelines for designing an application program.

5.12.4.1 Procedure for Entering/Exiting STOP mode

1. Program the polarity of the trigger event of external wake-up lines by writing registers WUTRH and WUTRL.
2. Check that at least one mask bit (registers WUMRH, WUMRL) is equal to 1 (so at least one external wake-up line is not masked).
3. Reset at least the unmasked pending bits: this allows a rising edge to be generated on the INTD1 channel when the trigger event occurs (an interrupt on channel INTD1 is recognized when a rising edge occurs).
4. Set the ID1S bit in the WUCTRL register and set the WKUP-INT bit.
5. To generate an interrupt on channel INTD1, bits EITR.1 (R242.7, Page 0) and EIMR.1 (R244.7, Page 0) must be set and bit EIPR.7 must be reset. Bits 7 and 6 of register R245, Page 0 must be written with the desired priority level for interrupt channel INTD1.
6. Reset the STOP bit in register WUCTRL and the EX_STP bit in the CLK_FLAG register (R242.7, Page 55). Refer to the RCCU chapter.
7. To enter STOP mode, write the sequence 1, 0, 1 to the STOP bit in the WUCTRL register with three consecutive write operations.
8. The code to be executed just after the STOP sequence must check the status of the STOP and RCCU EX_STP bits to determine if the ST9 entered STOP mode or not (See "Wake-up Mode Selection" on page 114. for details). If the ST9 did not enter in STOP mode it is necessary to reloop the procedure from the beginning, otherwise the procedure continues from next point.

9. Poll the wake-up pending bits to determine which wake-up line caused the exit from STOP mode.

10. Clear the wake-up pending bit that was set.

5.12.4.2 Simultaneous Setting of Pending Bits

It is possible that several simultaneous events set different pending bits. In order to accept subsequent events on external wake-up/interrupt lines, it is necessary to clear at least one pending bit: this operation allows a rising edge to be generated on the INTD1 line (if there is at least one more pending bit set and not masked) and so to set EIPR.7 bit again. A further interrupt on channel INTD1 will be serviced depending on the status of bit EIMR.7. Two possible situations may arise:

1. The user chooses to reset all pending bits: no further interrupt requests will be generated on channel INTD1. In this case the user has to:
 - Reset EIMR.7 bit (to avoid generating a spurious interrupt request during the next reset operation on the WUPRH register)
 - Reset WUPRH register using a read-modify-write instruction (AND, BRES, BAND)
 - Clear the EIPR.7 bit
 - Reset the WUPRL register using a read-modify-write instruction (AND, BRES, BAND)
2. The user chooses to keep at least one pending bit active: at least one additional interrupt request will be generated on the INTD1 channel. In this case the user has to reset the desired pending bits with a read-modify-write instruction (AND, BRES, BAND). This operation will generate a rising edge on the INTD1 channel and the EIPR.7 bit will be set again. An interrupt on the INTD1 channel will be serviced depending on the status of EIMR.7 bit.

WAKE-UP / INTERRUPT LINES MANAGEMENT UNIT (Cont'd)**WAKE-UP MASK REGISTER HIGH (WUMRH)**

R250 - Read/Write

Register Page: 57

Reset Value: 0000 0000 (00h)

7								0
WUM15	WUM14	WUM13	WUM12	WUM11	WUM10	WUM9	WUM8	

Bit 7:0 = **WUM[15:8]**: *Wake-Up Mask bits.*

If WUMx is set, an interrupt on channel INTD1 and/or a wake-up event (depending on ID1S and WKUP-INT bits) are generated if the corresponding WUPx pending bit is set. More precisely, if WUMx=1 and WUPx=1 then:

- If ID1S=1 and WKUP-INT=1 then an interrupt on channel INTD1 and a wake-up event are generated.
- If ID1S=1 and WKUP-INT=0 only an interrupt on channel INTD1 is generated.

If WUMx is reset, no wake-up events can be generated.

WAKE-UP MASK REGISTER LOW (WUMRL)

R251 - Read/Write

Register Page: 57

Reset Value: 0000 0000 (00h)

7								0
WUM7	WUM6	WUM5	WUM4	WUM3	WUM2	WUM1	WUM0	

Bit 7:0 = **WUM[7:0]**: *Wake-Up Mask bits.*

If WUMx is set, an interrupt on channel INTD1 and/or a wake-up event (depending on ID1S and WKUP-INT bits) are generated if the corresponding WUPx pending bit is set. More precisely, if WUMx=1 and WUPx=1 then:

- If ID1S=1 and WKUP-INT=1 then an interrupt on channel INTD1 and a wake-up event are generated.
- If ID1S=1 and WKUP-INT=0 only an interrupt on channel INTD1 is generated.

If WUMx is reset, no wake-up events can be generated.

WAKE-UP / INTERRUPT LINES MANAGEMENT UNIT (Cont'd)

WAKE-UP TRIGGER REGISTER HIGH (WUTRH)

R252 - Read/Write
 Register Page: 57
 Reset Value: 0000 0000 (00h)

7	0						
WUT15	WUT14	WUT13	WUT12	WUT11	WUT10	WUT9	WUT8

Bit 7:0 = **WUT[15:8]: Wake-Up Trigger Polarity Bits**

These bits are set and cleared by software.

- 0: The corresponding WUPx pending bit will be set on the falling edge of the input wake-up line .
- 1: The corresponding WUPx pending bit will be set on the rising edge of the input wake-up line.

WAKE-UP TRIGGER REGISTER LOW (WUTRL)

R253 - Read/Write
 Register Page: 57
 Reset Value: 0000 0000 (00h)

7	0						
WUT7	WUT6	WUT5	WUT4	WUT3	WUT2	WUT1	WUT0

Bit 7:0 = **WUT[7:0]: Wake-Up Trigger Polarity Bits**

These bits are set and cleared by software.

- 0: The corresponding WUPx pending bit will be set on the falling edge of the input wake-up line.
- 1: The corresponding WUPx pending bit will be set on the rising edge of the input wake-up line.

WARNING

1. As the external wake-up lines are edge triggered, no glitches must be generated on these lines.
2. If either a rising or a falling edge on the external wake-up lines occurs while writing the WUTRLH or WUTRL registers, the pending bit will not be set.

WAKE-UP PENDING REGISTER HIGH (WUPRH)

R254 - Read/Write
 Register Page: 57
 Reset Value: 0000 0000 (00h)

7	0						
WUP15	WUP14	WUP13	WUP12	WUP11	WUP10	WUP9	WUP8

Bit 7:0 = **WUP[15:8]: Wake-Up Pending Bits**

These bits are set by hardware on occurrence of the trigger event on the corresponding wake-up line. They must be cleared by software. They can be set by software to implement a software interrupt.

- 0: No Wake-up Trigger event occurred
- 1: Wake-up Trigger event occurred

WAKE-UP PENDING REGISTER LOW (WUPRL)

R255 - Read/Write
 Register Page: 57
 Reset Value: 0000 0000 (00h)

7	0						
WUP7	WUP6	WUP5	WUP4	WUP3	WUP2	WUP1	WUP0

Bit 7:0 = **WUP[7:0]: Wake-Up Pending Bits**

These bits are set by hardware on occurrence of the trigger event on the corresponding wake-up line. They must be cleared by software. They can be set by software to implement a software interrupt.

- 0: No Wake-up Trigger event occurred
- 1: Wake-up Trigger event occurred

Note: To avoid losing a trigger event while clearing the pending bits, **it is recommended** to use read-modify-write instructions (AND, BRES, BAND) to clear them.

5.12.6 Important Note On WUIMU

Refer to [Section 13.2 on page 409](#).

6 ON-CHIP DIRECT MEMORY ACCESS (DMA)

6.1 INTRODUCTION

The ST9 includes on-chip Direct Memory Access (DMA) in order to provide high-speed data transfer between peripherals and memory or Register File. Multi-channel DMA is fully supported by peripherals having their own controller and DMA channel(s). Each DMA channel transfers data to or from contiguous locations in the Register File, or in Memory. The maximum number of bytes that can be transferred per transaction by each DMA channel is 222 with the Register File, or 65536 with Memory.

The DMA controller in the Peripheral uses an indirect addressing mechanism to DMA Pointers and Counter Registers stored in the Register File. This is the reason why the maximum number of transactions for the Register File is 222, since two Registers are allocated for the Pointer and Counter. Register pairs are used for memory pointers and counters in order to offer the full 65536 byte and count capability.

6.2 DMA PRIORITY LEVELS

The 8 priority levels used for interrupts are also used to prioritize the DMA requests, which are arbitrated in the same arbitration phase as interrupt requests. If the event occurrence requires a DMA transaction, this will take place at the end of the current instruction execution. When an interrupt and a DMA request occur simultaneously, on the same priority level, the DMA request is serviced before the interrupt.

An interrupt priority request must be strictly higher than the CPL value in order to be acknowledged, whereas, for a DMA transaction request, it must be equal to or higher than the CPL value in order to be executed. Thus only DMA transaction requests can be acknowledged when the CPL=0.

DMA requests do not modify the CPL value, since the DMA transaction is not interruptable.

Figure 56. DMA Data Transfer

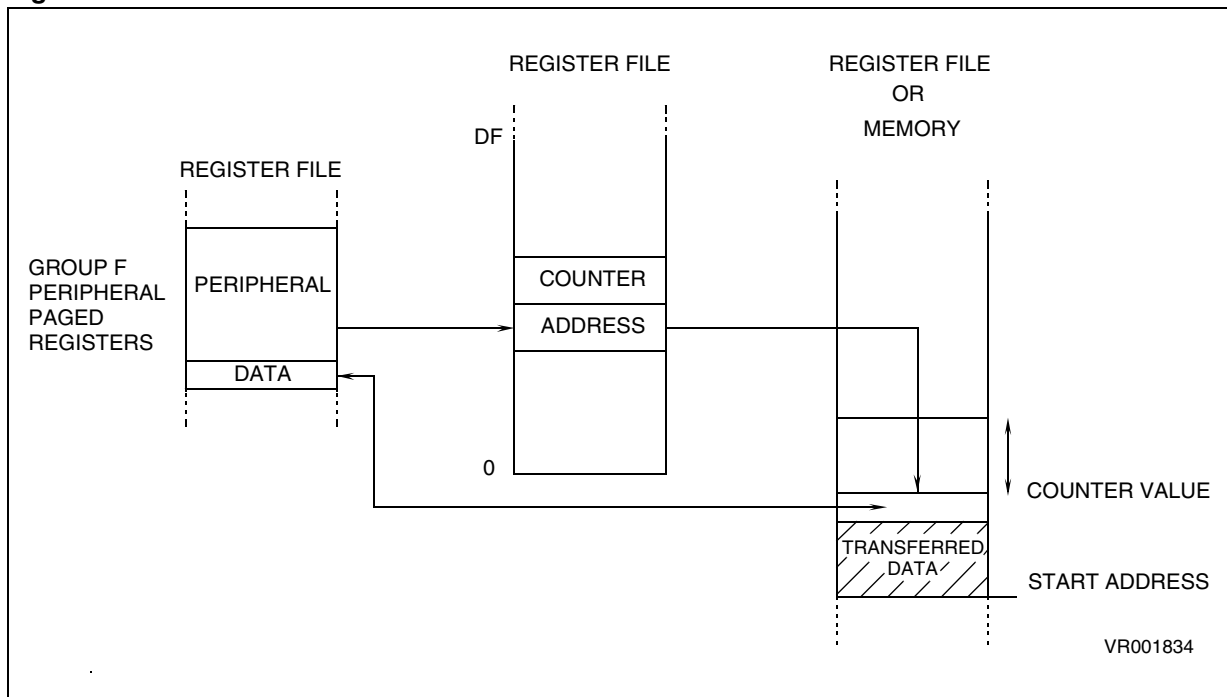

6.3 DMA TRANSACTIONS

The purpose of an on-chip DMA channel is to transfer a block of data between a peripheral and the Register File, or Memory. Each DMA transfer consists of three operations:

- A load from/to the peripheral data register to/from a location of Register File (or Memory) addressed through the DMA Address Register (or Register pair)
- A post-increment of the DMA Address Register (or Register pair)
- A post-decrement of the DMA transaction counter, which contains the number of transactions that have still to be performed.

If the DMA transaction is carried out between **the peripheral and the Register File** (Figure 57), one register is required to hold the DMA Address, and one to hold the DMA transaction counter. These two registers must be located in the Register File: the DMA Address Register in the even address

register, and the DMA Transaction Counter in the next register (odd address). They are pointed to by the DMA Transaction Counter Pointer Register (DCPR), located in the peripheral's paged registers. In order to select a DMA transaction with the Register File, the control bit DCPR.RM (bit 0 of DCPR) must be set.

If the transaction is made between **the peripheral and Memory**, a register pair (16 bits) is required for the DMA Address and the DMA Transaction Counter (Figure 58). Thus, two register pairs must be located in the Register File.

The DMA Transaction Counter is pointed to by the DMA Transaction Counter Pointer Register (DCPR), the DMA Address is pointed to by the DMA Address Pointer Register (DAPR), both DCPR and DAPR are located in the paged registers of the peripheral.

Figure 57. DMA Between Register File and Peripheral

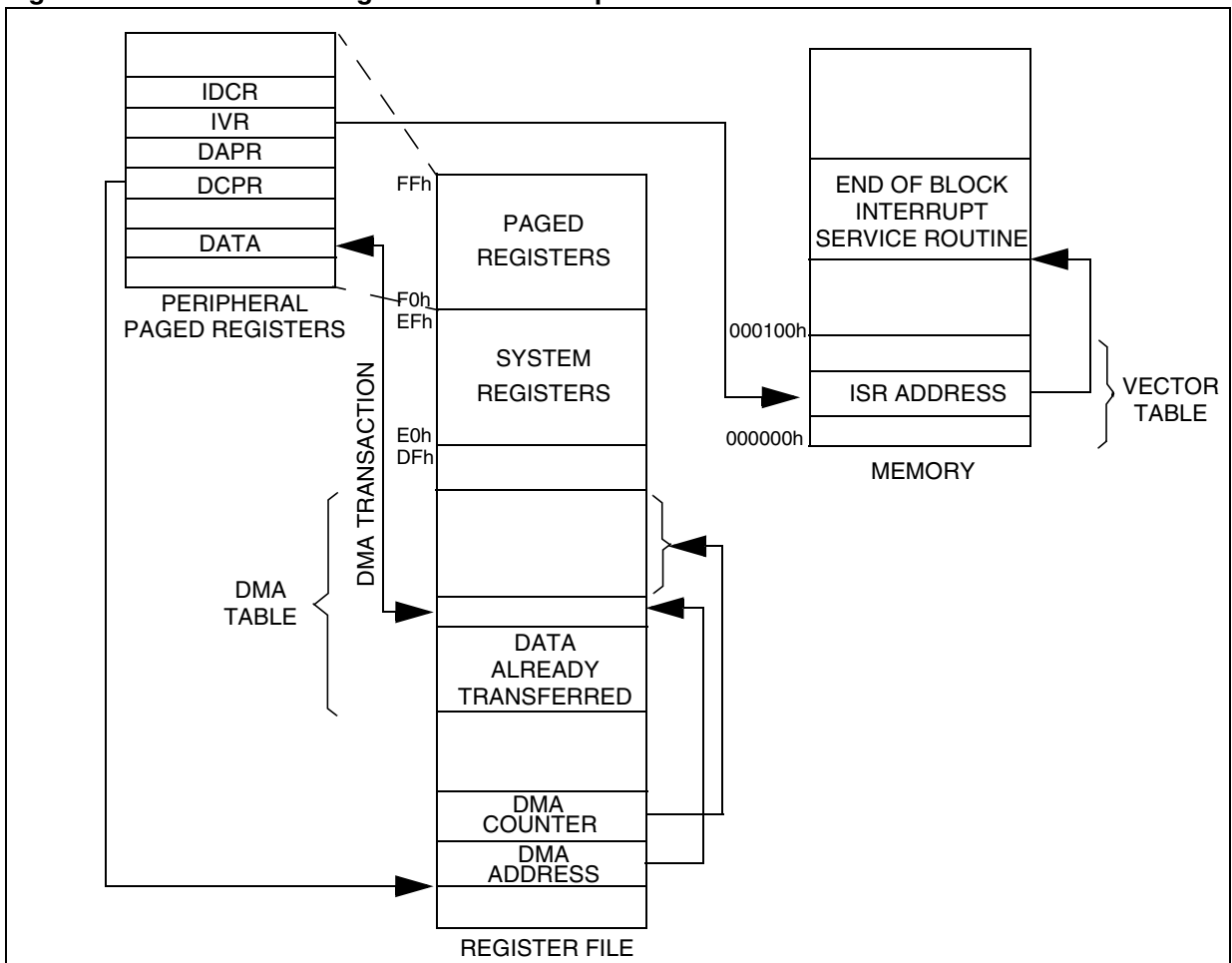

DMA TRANSACTIONS (Cont'd)

When selecting the DMA transaction with memory, bit DCPR.RM (bit 0 of DCPR) must be cleared.

To select between using the ISR or the DMASR register to extend the address, (see Memory Management Unit chapter), the control bit DAPR.PS (bit 0 of DAPR) must be cleared or set respectively.

The DMA transaction Counter must be initialized with the number of transactions to perform and will be decremented after each transaction. The DMA Address must be initialized with the starting address of the DMA table and is increased after each transaction. These two registers must be located between addresses 00h and DFh of the Register File.

Once a DMA channel is initialized, a transfer can start. The direction of the transfer is automatically defined by the type of peripheral and programming mode.

Once the DMA table is completed (the transaction counter reaches 0 value), an Interrupt request to the CPU is generated.

When the Interrupt Pending (IDCR.IP) bit is set by a hardware event (or by software), and the DMA Mask bit (IDCR.DM) is set, a DMA request is generated. If the Priority Level of the DMA source is higher than, or equal to, the Current Priority Level (CPL), the DMA transfer is executed at the end of the current instruction. DMA transfers read/write data from/to the location pointed to by the DMA Address Register, the DMA Address register is incremented and the Transaction Counter Register is decremented. When the contents of the Transaction Counter are decremented to zero, the DMA Mask bit (DM) is cleared and an interrupt request is generated, according to the Interrupt Mask bit (End of Block interrupt). This End-of-Block interrupt request is taken into account, depending on the PRL value.

WARNING. DMA requests are not acknowledged if the top level interrupt service is in progress.

Figure 58. DMA Between Memory and Peripheral

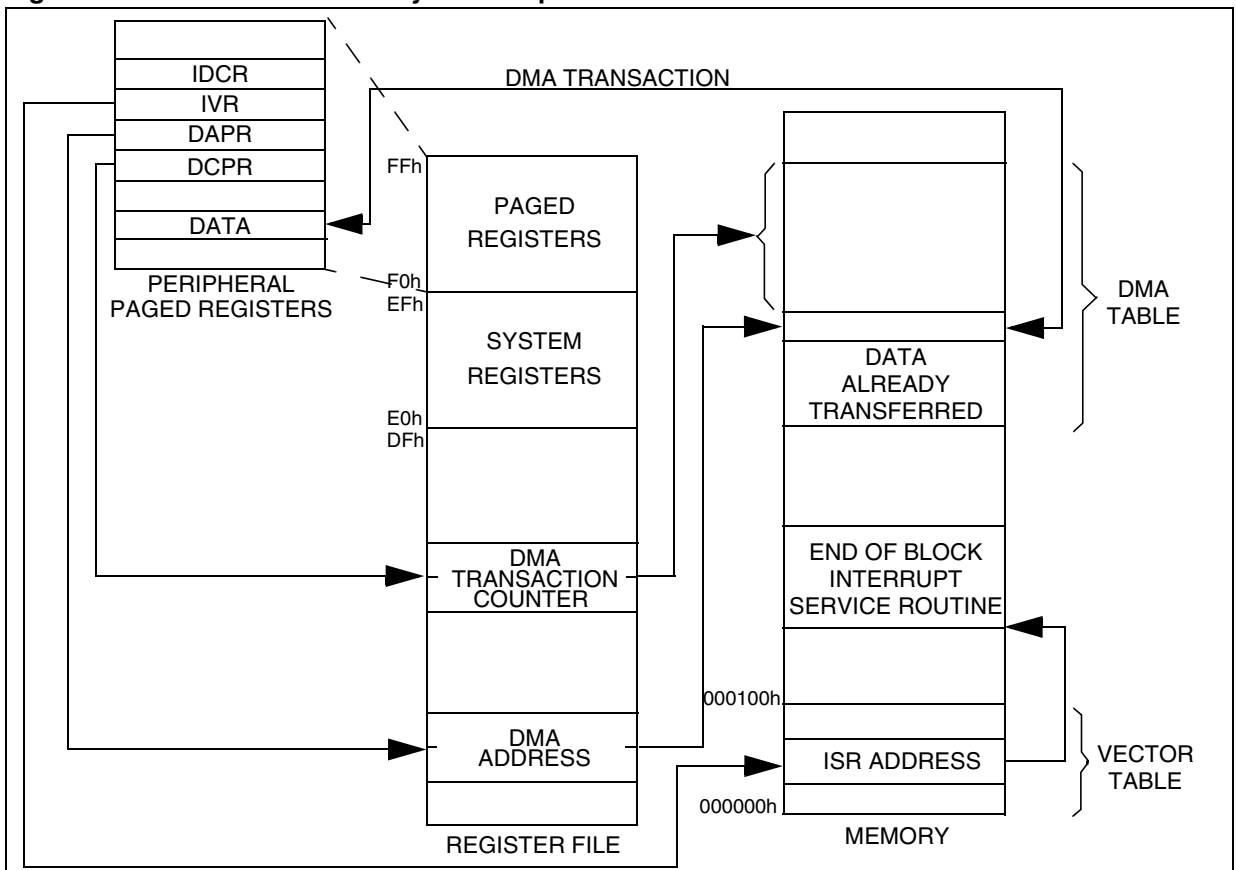

DMA TRANSACTIONS (Cont'd)

6.4 DMA CYCLE TIME

The interrupt and DMA arbitration protocol functions completely asynchronously from instruction flow.

Requests are sampled every 5 CPUCLK cycles.

DMA transactions are executed if their priority allows it.

A DMA transfer with the Register file requires 8 CPUCLK cycles.

A DMA transfer with memory requires 16 CPUCLK cycles, plus any required wait states.

6.5 SWAP MODE

An extra feature which may be found on the DMA channels of some peripherals (e.g. the MultiFunction Timer) is the Swap mode. This feature allows

transfer from two DMA tables alternatively. All the DMA descriptors in the Register File are thus doubled. Two DMA transaction counters and two DMA address pointers allow the definition of two fully independent tables (they only have to belong to the same space, Register File or Memory). The DMA transaction is programmed to start on one of the two tables (say table 0) and, at the end of the block, the DMA controller automatically swaps to the other table (table 1) by pointing to the other DMA descriptors. In this case, the DMA mask (DM bit) control bit is not cleared, but the End Of Block interrupt request is generated to allow the optional updating of the first data table (table 0).

Until the swap mode is disabled, the DMA controller will continue to swap between DMA Table 0 and DMA Table 1.

6.6 DMA REGISTERS

As each peripheral DMA channel has its own specific control registers, the following register list should be considered as a general example. The names and register bit allocations shown here may be different from those found in the peripheral chapters.

DMA COUNTER POINTER REGISTER (DCPR)

Read/Write

Address set by Peripheral

Reset value: undefined

7								0
C7	C6	C5	C4	C3	C2	C1	RM	

Bit 7:1 = **C[7:1]**: DMA Transaction Counter Pointer.

Software should write the pointer to the DMA Transaction Counter in these bits.

Bit 0 = **RM**: Register File/Memory Selector.

This bit is set and cleared by software.

0: DMA transactions are with memory (see also DAPR.DP)

1: DMA transactions are with the Register File

GENERIC EXTERNAL PERIPHERAL INTERRUPT AND DMA CONTROL (IDCR)

Read/Write

Address set by Peripheral

Reset value: undefined

7								0
		IP	DM	IM	PRL2	PRL1	PRL0	

Bit 5 = **IP**: Interrupt Pending.

This bit is set by hardware when the Trigger Event occurs. It is cleared by hardware when the request is acknowledged. It can be set/cleared by software in order to generate/cancel a pending request.

0: No interrupt pending

1: Interrupt pending

Bit 4 = **DM**: DMA Request Mask.

This bit is set and cleared by software. It is also cleared when the transaction counter reaches zero (unless SWAP mode is active).

0: No DMA request is generated when IP is set.

1: DMA request is generated when IP is set

Bit 3 = **IM**: End of block Interrupt Mask.

This bit is set and cleared by software.

0: No End of block interrupt request is generated when IP is set

1: End of Block interrupt is generated when IP is set. DMA requests depend on the DM bit value as shown in the table below.

DM	IM	Meaning
1	0	A DMA request generated without End of Block interrupt when IP=1
1	1	A DMA request generated with End of Block interrupt when IP=1
0	0	No End of block interrupt or DMA request is generated when IP=1
0	1	An End of block Interrupt is generated without associated DMA request (not used)

Bit 2:0 = **PRL[2:0]**: Source Priority Level.

These bits are set and cleared by software. Refer to Section 6.2 DMA PRIORITY LEVELS for a description of priority levels.

PRL2	PRL1	PRL0	Source Priority Level
0	0	0	0 Highest
0	0	1	1
0	1	0	2
0	1	1	3
1	0	0	4
1	0	1	5
1	1	0	6
1	1	1	7 Lowest

DMA ADDRESS POINTER REGISTER (DAPR)

Read/Write

Address set by Peripheral

Reset value: undefined

7								0
A7	A6	A5	A4	A3	A2	A1	PS	

Bit 7:1 = **A[7:1]**: DMA Address Register(s) Pointer

Software should write the pointer to the DMA Address Register(s) in these bits.

Bit 0 = **PS**: Memory Segment Pointer Selector.

This bit is set and cleared by software. It is only meaningful if DCPR.RM=0.

0: The ISR register is used to extend the address of data transferred by DMA (see MMU chapter).

1: The DMASR register is used to extend the address of data transferred by DMA (see MMU chapter).

7 RESET AND CLOCK CONTROL UNIT (RCCU)

7.1 INTRODUCTION

The Reset and Clock Control Unit (RCCU) comprises two distinct sections:

- the Clock Control Unit, which generates and manages the internal clock signals.
- the Reset/Stop Manager, which detects and flags Hardware, Software and Watchdog generated resets.

On ST9 devices where the external Stop pin and/or the Wake-Up Interrupt Manager Unit are available, this circuit also detects and manages the Stop mode during which all oscillators are frozen in order to achieve the lowest possible power consumption (refer to the Reset/Stop mode and Wake-Up Interrupt Manager Unit description).

7.2 CLOCK CONTROL UNIT

The Clock Control Unit generates the internal clocks for the CPU core (CPUCLK) and for the on-chip peripherals (INTCLK). The Clock Control Unit may be driven by the on-chip oscillator (provided an external crystal circuit is connected to the OSCIN and OSCOUT pins), or by an external pulse generator, connected to OSCOUT (see [Figure 66](#) and [Figure 68](#)). When significant power reduction is required, a low frequency external clock may be selected. To do this, this clock source must be connected to the CK_AF pin.

7.2.1 Clock Control Unit Overview

As shown in [Figure 59](#) a programmable divider can divide the CLOCK1 input clock signal by two. In practice, the divide-by-two is virtually always used in order to ensure a 50% duty cycle signal to

the PLL multiplier circuit. The resulting signal, CLOCK2, is the reference input clock to the programmable Phase Locked Loop frequency multiplier, which is capable of multiplying the clock frequency by a factor of 6, 8, 10 or 14; the multiplied clock is then divided by a programmable divider, by a factor of 1 to 7. By these means, the ST9 can operate with cheaper, medium frequency (3-5 MHz) crystals, while still providing a high frequency internal clock for maximum system performance; the range of available multiplication and division factors allow a great number of operating clock frequencies to be derived from a single crystal frequency.

For low power operation, especially in Wait for Interrupt mode, the Clock Multiplier unit may be turned off, whereupon the output clock signal may be programmed as CLOCK2 divided by 16. For further power reduction, a low frequency external clock connected to the CK_AF pin may be selected, whereupon the crystal controlled main oscillator may be turned off.

The internal system clock, INTCLK, is routed to all on-chip peripherals, as well as to the programmable Clock Prescaler Unit which generates the clock for the CPU core (CPUCLK). (See [Figure 59](#))

The Clock Prescaler is programmable and can slow the CPU clock by a factor of up to 8, allowing the programmer to reduce CPU processing speed, and thus power consumption, while maintaining a high speed clock to the peripherals. This is particularly useful when little actual processing is being done by the CPU and the peripherals are doing most of the work.

Figure 59. Clock Control Unit Simplified Block Diagram

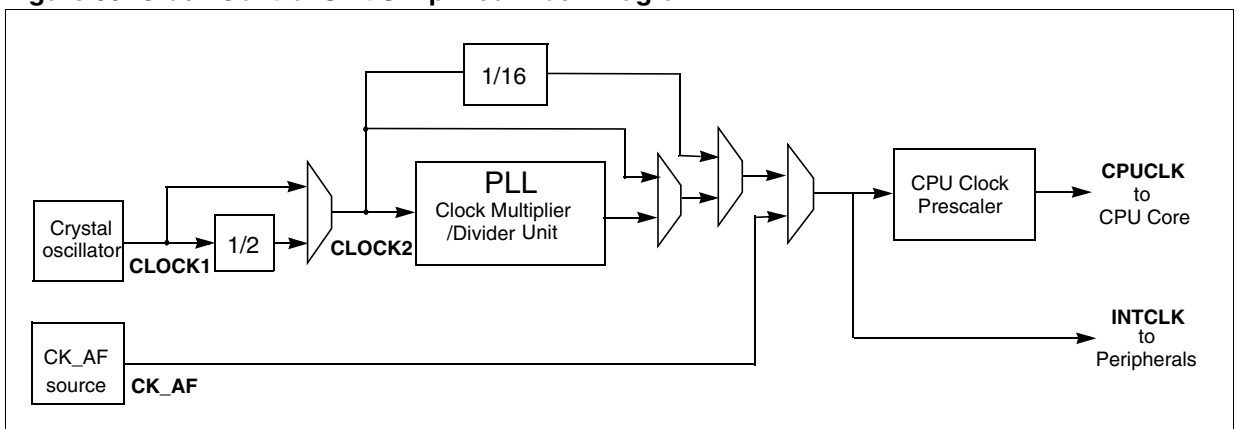
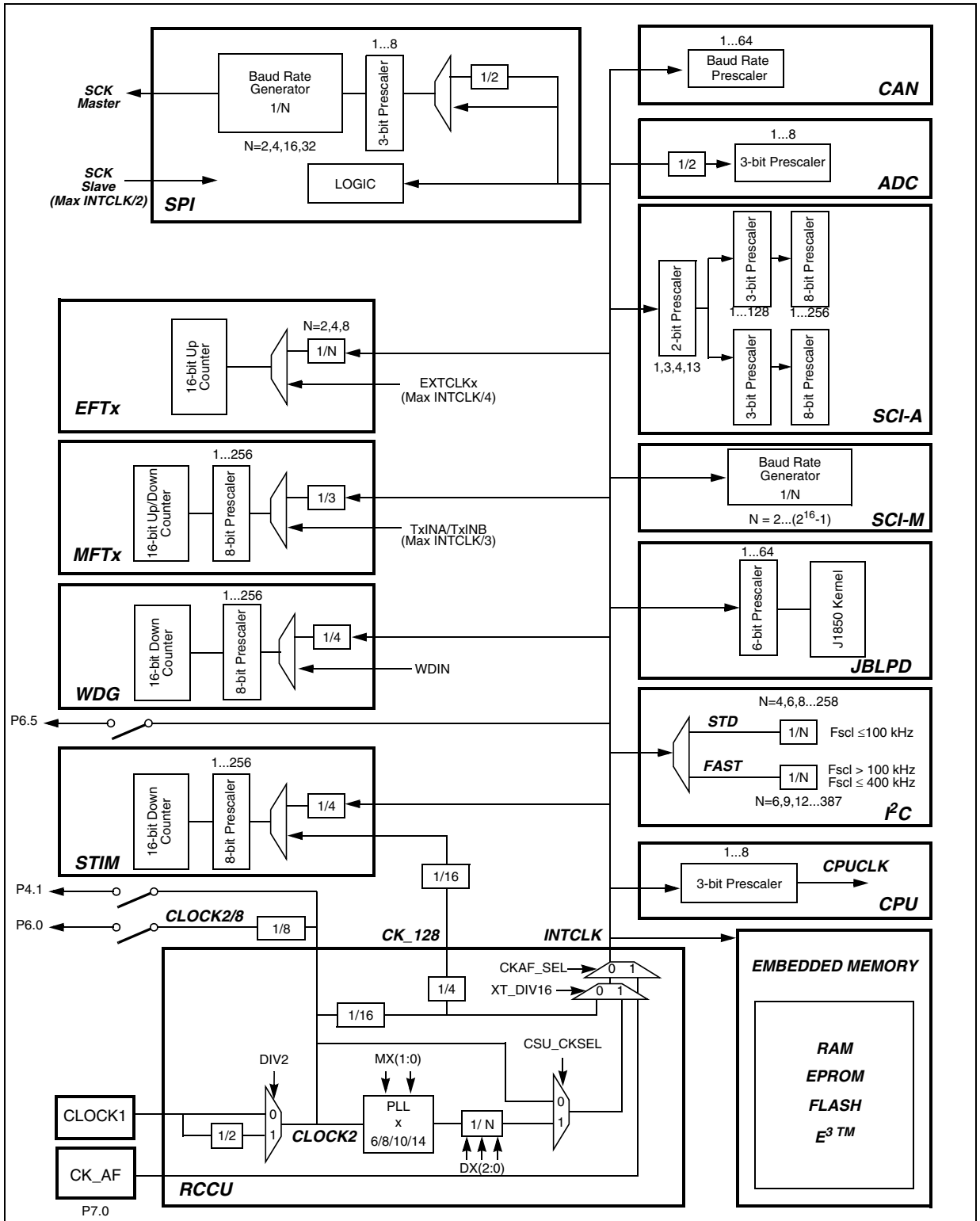

Figure 60. ST92F124/F150/F250 Clock Distribution Diagram



7.3 CLOCK MANAGEMENT

The various programmable features and operating modes of the CCU are handled by four registers:

- **MODER** (Mode Register)
This is a System Register (R235, Group E).
The input clock divide-by-two and the CPU clock prescaler factors are handled by this register.
- **CLK_FLAG** (Clock Flag Register)
This is a Paged Register (R242, Page 55).
This register contains various status flags, as well as control bits for clock selection.
- **CLKCTL** (Clock Control Register)
This is a Paged Register (R240, Page 55).
The low power modes, the RCCU interrupts and the interpretation of the HALT instruction are handled by this register.
- **PLLCONF** (PLL Configuration Register)
This is a Paged Register (R246, Page 55).
PLL management is programmed in this register.

Figure 61. Clock Control Unit Programming

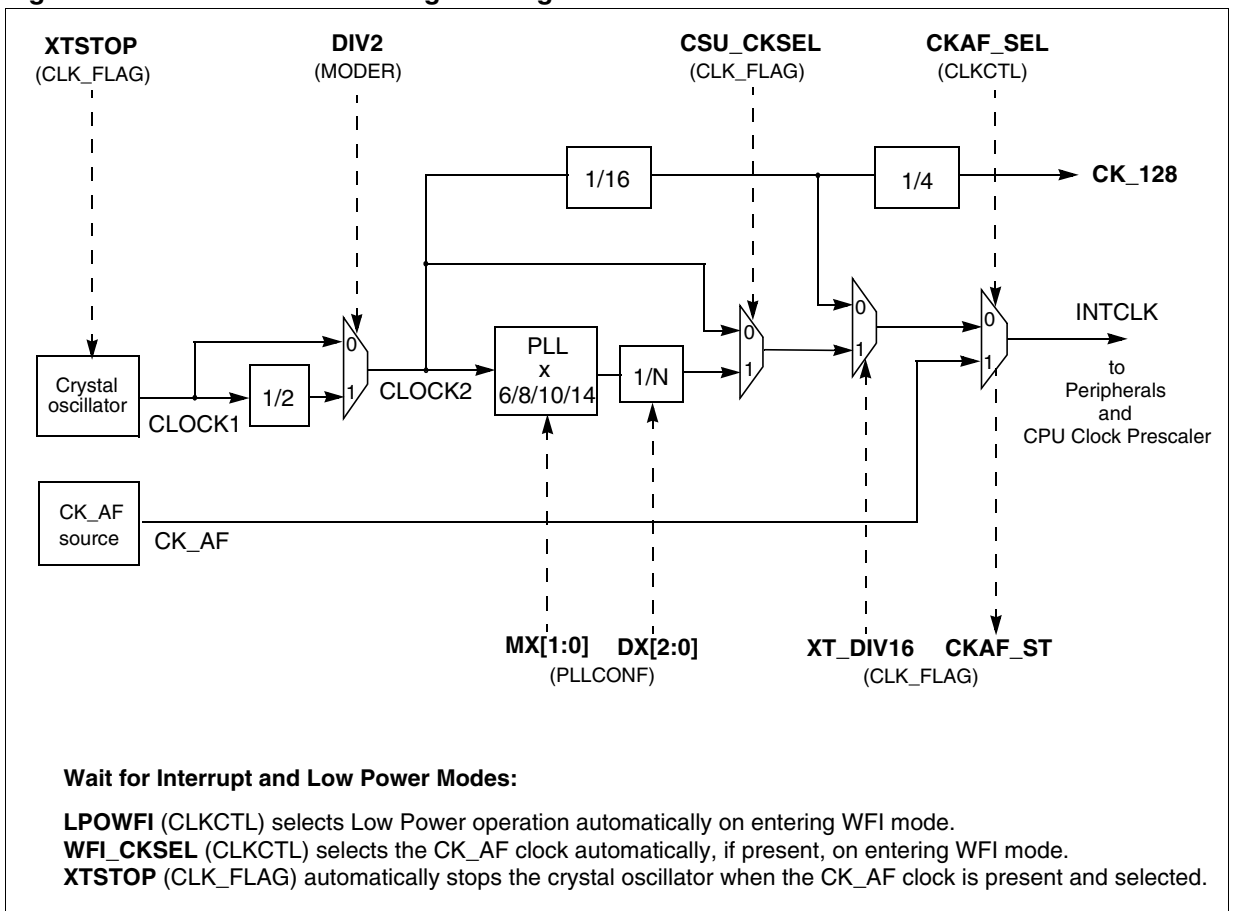

CLOCK MANAGEMENT (Cont'd)
7.3.1 PLL Clock Multiplier Programming

The CLOCK1 signal generated by the oscillator drives a programmable divide-by-two circuit. If the DIV2 control bit in MODER is set (Reset Condition), CLOCK2, is equal to CLOCK1 divided by two; if DIV2 is reset, CLOCK2 is identical to CLOCK1. Since the input clock to the Clock Multiplier circuit requires a 50% duty cycle for correct PLL operation, the divide by two circuit should be enabled when a crystal oscillator is used, or when the external clock generator does not provide a 50% duty cycle. In practice, the divide-by-two is virtually always used in order to ensure a 50% duty cycle signal to the PLL multiplier circuit.

When the PLL is active, it multiplies CLOCK2 by 6, 8, 10 or 14, depending on the status of the MX[0:1] bits in PLLCONF. The multiplied clock is then divided by a factor in the range 1 to 7, determined by the status of the DX[0:2] bits; when these bits are programmed to 111, the PLL is switched off.

Following a RESET phase, programming bits DX0-2 to a value different from 111 will turn the PLL on. After allowing a stabilization period for the PLL, setting the CSU_CKSEL bit in the CLK_FLAG Register selects the multiplier clock. The RCCU contains a frequency comparator between CLOCK2 and the PLL clock output that verifies if the PLL reaches the programmed frequency and has stabilized (locked status). When this condition occurs, the LOCK bit in the CLK_FLAG register is set to 1 by hardware and this value is maintained as long as the PLL is locked. The LOCK bit is set back to 0 if for some reason (change of MX bit value, stop and restart of PLL or CLOCK2, etc.), the PLL loses the programmed frequency in which it was locked.

The PLL selection as system clock is further conditioned by the status of the Voltage Regulator: when it is not providing a stabilized supply voltage, the PLL cannot be selected.

The maximum frequency allowed for INTCLK is 24 MHz. Care is required, when programming the PLL multiplier and divider factors, not to exceed the maximum permissible operating frequency for INTCLK, according to supply voltage, as reported in Electrical Characteristics section.

The ST9 being a static machine, there is no lower limit for INTCLK. However, some peripherals have their own minimum internal clock frequency limit below which the functionality is not guaranteed.

7.3.2 PLL Free Running Mode

The PLL is able to provide a 50-kHz clock, usable to slow program execution. This mode is controlled by the FREEN and DX[2:0] bits in the PLLCONF register: when the PLL is off and the FREEN bit is set to 1 (i.e. when the FREEN and DX[2:0] bits are set to 1), the PLL provides this clock. The selection of this clock is also managed by the CSU_CKSEL bit but is not conditioned by the LOCK bit. To avoid unpredictable behaviour of the PLL clock, Free Running mode must be set and reset by the user only when the PLL clock is not the system clock, i.e. when the CSU_CKSEL bit is reset.

In addition, when the PLL provides the internal clock, if the clock signal disappears (for instance due to a broken or disconnected resonator...), a safety clock signal is automatically provided, allowing the ST9 to perform some rescue operations.

Typ. Safety clock frequency = 800 kHz / Div, where Div depends on the DX[0..2] bits of the PLLCONF register (R246, page55).

Table 26. Free Running Clock Frequency

DX2	DX1	DX0	DIV	CK (Typ.)
0	0	0	2	400 kHz
0	0	1	4	200 kHz
0	1	0	6	133 kHz
0	1	1	8	100 kHz
1	0	0	10	80 kHz
1	0	1	12	67 kHz
1	1	0	14	57 kHz
1	1	1	16	50 kHz (CSU_CKSEL=0; FREEN=1)
1	1	1	-	CLOCK2 (CSU_CKSEL=0; FREEN=0)

CLOCK MANAGEMENT (Cont'd)

7.3.3 CPU Clock Prescaling

The system clock, INTCLK, which may be the output of the PLL clock multiplier, CLOCK2, CLOCK2/16 or CK_AF, drives a programmable prescaler which generates the basic time base, CPUCLK, for the instruction executor of the ST9 CPU core. This allows the user to slow down program execution during non processor intensive routines, thus reducing power dissipation.

The internal peripherals are not affected by the CPUCLK prescaler and continue to operate at the full INTCLK frequency. This is particularly useful when little processing is being done and the peripherals are doing most of the work.

The prescaler divides the input clock by the value programmed in the control bits PRS2,1,0 in the MODER register. If the prescaler value is zero, no prescaling takes place, thus CPUCLK has the same period and phase as INTCLK. If the value is different from 0, the prescaling is equal to the value plus one, ranging thus from two (PRS[2:0] = 1) to eight (PRS[2:0] = 7).

The clock generated is shown in Figure 62, and it will be noted that the prescaling of the clock does not preserve the 50% duty cycle, since the high level is stretched to replace the missing cycles.

This is analogous to the introduction of wait cycles for access to external memory. When External Memory Wait or Bus Request events occur, CPUCLK is stretched at the high level for the whole period required by the function

Figure 62. CPU Clock Prescaling

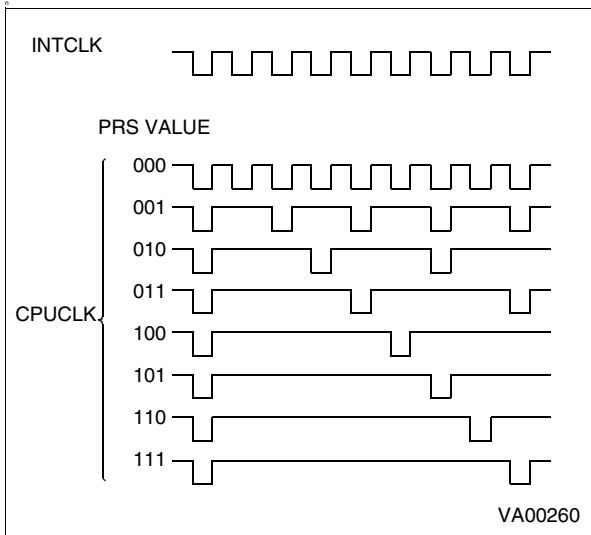

7.3.4 Peripheral Clock

The system clock, INTCLK, which may be the output of the PLL clock multiplier, CLOCK2, CLOCK2/16 or CK_AF, is also routed to all ST9 on-chip peripherals and acts as the central timebase for all timing functions.

7.3.5 Low Power Modes

The user can select an automatic slowdown of clock frequency during Wait for Interrupt operation, thus idling in low power mode while waiting for an interrupt. In WFI operation the clock to the CPU core is stopped, thus suspending program execution, while the clock to the peripherals may be programmed as described in the following paragraphs. Two examples of Low Power operation in WFI are illustrated in Figure 63 and Figure 64.

Providing that low power operation during Wait for Interrupt is enabled (by setting the LPOWFI bit in the CLKCTL Register), as soon as the CPU executes the WFI instruction, the PLL is turned off and the system clock will be forced to CLOCK2 divided by 16, or to the external low frequency clock, CK_AF, if this has been selected by setting WFI_CKSEL, and providing CKAF_ST is set, thus indicating that the external clock is selected and actually present on the CK_AF pin.

If the external clock source is used, the crystal oscillator may be stopped by setting the XTSTOP bit, providing that the CK_AF clock is present and selected, indicated by CKAF_ST being set. In this case, the crystal oscillator will be stopped automatically on entering WFI if the WFI_CKSEL bit has been set.

It should be noted that selecting a non-existent CK_AF clock source is impossible, since such a selection requires that the auxiliary clock source be actually present and selected. In no event can a non-existent clock source be selected inadvertently.

It is up to the user program to switch back to a faster clock on the occurrence of an interrupt, taking care to respect the oscillator and PLL stabilization delays, as appropriate.

It should be noted that any of the low power modes may also be selected explicitly by the user program even when not in Wait for Interrupt mode, by setting the appropriate bits.

If the FREEN bit is set, the PLL is not stopped during Low Power WFI, increasing power consumption.

CLOCK MANAGEMENT (Cont'd)

7.3.6 Interrupt Generation

System clock selection modifies the CLKCTL and CLK_FLAG registers.

The clock control unit generates an external interrupt request (INTD0) in the following conditions:

- when CK_AF and CLOCK2/16 are selected or deselected as system clock source,

- when the system clock restarts after a hardware stop (when the STOP MODE feature is available on the specific device).

- when the PLL loses the programmed frequency in which it was locked, and when it re-locks

This interrupt can be masked by resetting the INT_SEL bit in the CLKCTL register. Note that this is the only case in the ST9 where an interrupt is generated with a high to low transition.

Table 27. Summary of Operating Modes using main Crystal Controlled Oscillator

MODE	INTCLK	CPUCLK	DIV2	PRS0-2	CSU_CKSEL	MX0-1	DX2-0	LPOWFI	WFI_CKSEL	XT_DIV16
PLL x BY 14	XTAL/2 x (14/D)	INTCLK/N	1	N-1	1	1 0	D-1	X	X	1
PLL x BY 10	XTAL/2 x (10/D)	INTCLK/N	1	N-1	1	0 0	D-1	X	X	1
PLL x BY 8	XTAL/2 x (8/D)	INTCLK/N	1	N-1	1	1 1	D-1	X	X	1
PLL x BY 6	XTAL/2 x (6/D)	INTCLK/N	1	N-1	1	0 1	D-1	X	X	1
SLOW 1	XTAL/2	INTCLK/N	1	N-1	X	X	111	X	X	1
SLOW 2	XTAL/32	INTCLK/N	1	N-1	X	X	X	X	X	0
SLOW3	CK_AF	CK_AF/N	X	N-1	X	X	X	X	X	X
WFI	If LPOWFI=0, no changes occur on INTCLK, but CPUCLK is stopped anyway.									
LOW POWER WFI 1	XTAL/32	STOP	1	X	X	X	X	1	0	X
LOW POWER WFI 2	CK_AF	STOP	1	X	X	X	X	1	1	X
RESET	XTAL/2	INTCLK	1	0	0	00	111	0	0	1
EXAMPLE XTAL=4.4 MHz	2.2*10/2 = 11MHz	11MHz	1	0	1	00	001	X		1

Figure 63. Example of Low Power mode programming in WFI using CK_AF external clock

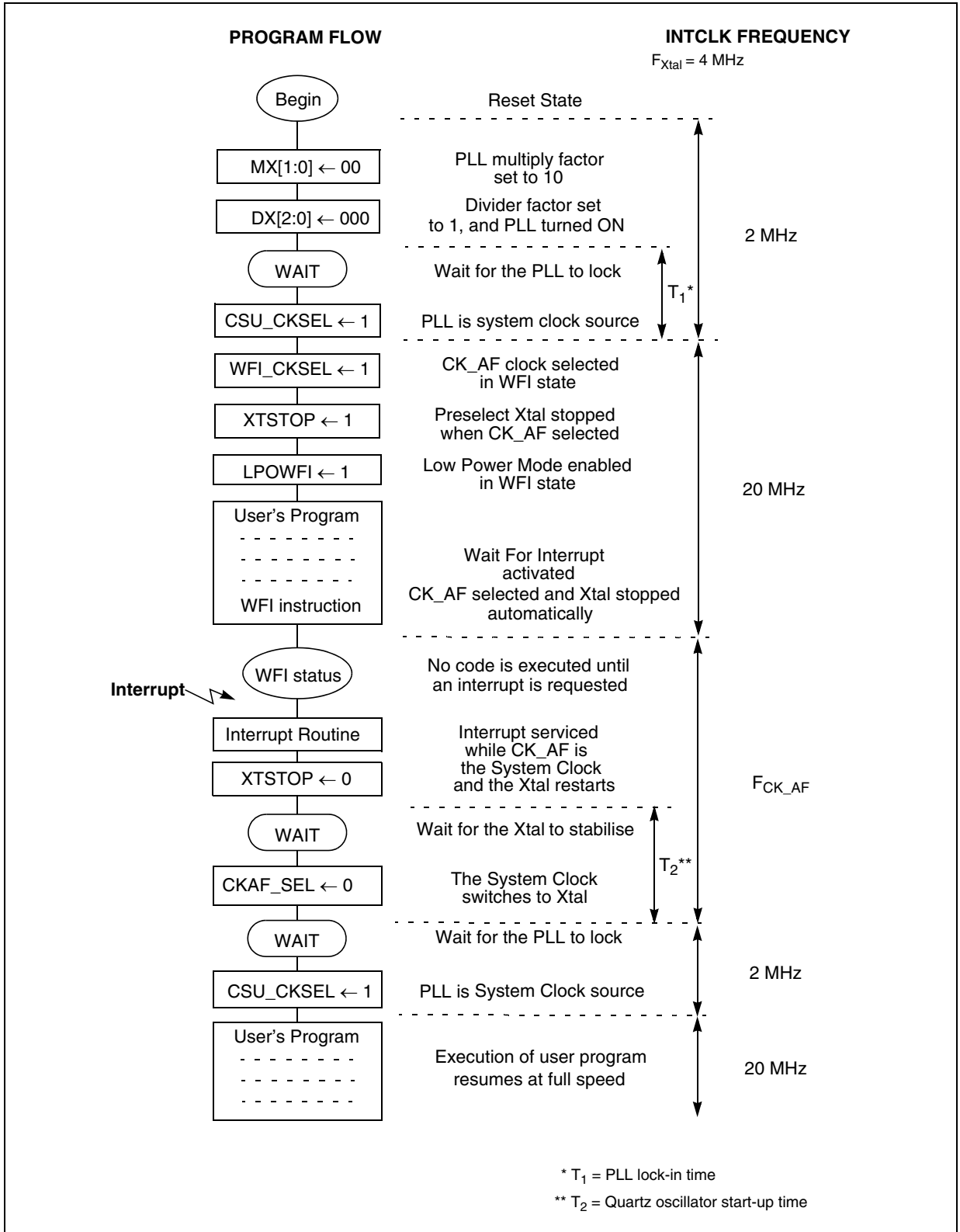
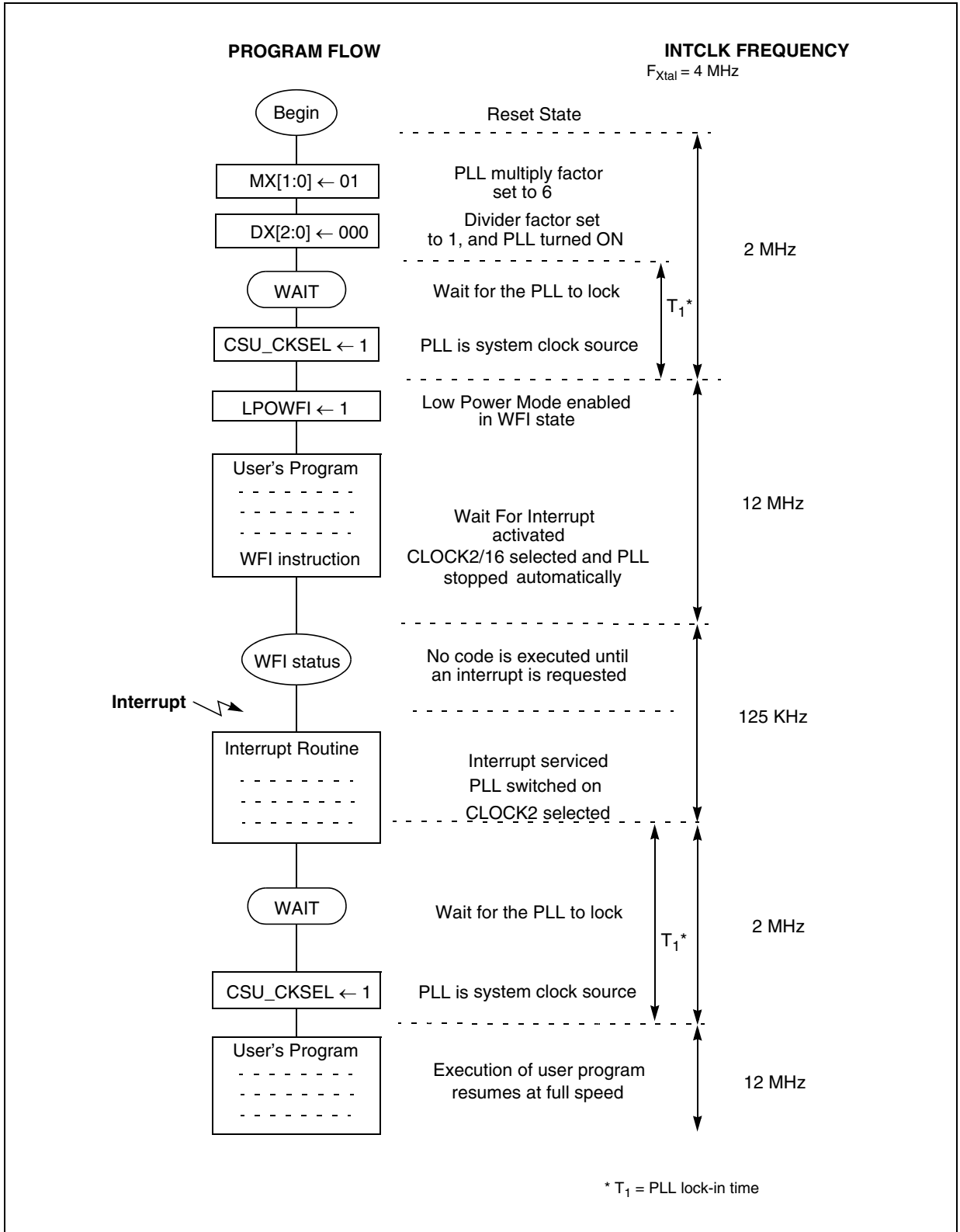

Figure 64. Example of Low Power mode programming in WFI using CLOCK2/16



7.4 CLOCK CONTROL REGISTERS

MODE REGISTER (MODER)

R235 - Read/Write
System Register
Reset Value: 1110 0000 (E0h)

7							0
-	-	DIV2	PRS2	PRS1	PRS0	-	-

***Note:** This register contains bits which relate to other functions; these are described in the chapter dealing with Device Architecture. Only those bits relating to Clock functions are described here.

Bit 5 = **DIV2:** Crystal Oscillator Clock Divided by 2. This bit controls the divide by 2 circuit which operates on CLOCK1.
0: No division of CLOCK1
1: CLOCK1 is internally divided by 2

Bits 4:2 = **PRS[2:0]:** Clock Prescaling. These bits define the prescaler value used to prescale CPUCLK from INTCLK. When these three bits are reset, the CPUCLK is not prescaled, and is equal to INTCLK; in all other cases, the internal clock is prescaled by the value of these three bits plus one.

CLOCK CONTROL REGISTER (CLKCTL)

R240 - Read/Write
Register Page: 55
Reset Value: 0000 0000 (00h)

7							0
INT_S EL	-	-	-	SRE- SEN	CKAF_S EL	WFLCKS EL	LPOW FI

Bit 7 = **INT_SEL:** Interrupt Selection.
0: The external interrupt channel input signal is selected (Reset state)
1: Select the internal RCCU interrupt as the source of the interrupt request

Bits 6:4 = **Reserved for test purposes**
Must be kept reset for normal operation.

Bit 3 = **SRESEN:** Software Reset Enable.
0: The HALT instruction turns off the quartz, the PLL and the CCU
1: A Reset is generated when HALT is executed

Bit 2 = **CKAF_SEL:** Alternate Function Clock Select.
0: CK_AF clock not selected
1: Select CK_AF clock

Note: To check if the selection has actually occurred, check that CKAF_ST is set. If no clock is present on the CK_AF pin, the selection will not occur.

Bit 1 = **WFI_CKSEL:** WFI Clock Select. This bit selects the clock used in Low power WFI mode if LPOWFI = 1.
0: INTCLK during WFI is CLOCK2/16
1: INTCLK during WFI is CK_AF, providing it is present. In effect this bit sets CKAF_SEL in WFI mode

WARNING: When the CK_AF is selected as Low Power WFI clock but the crystal is not turned off (R242.4 = 0), after exiting from the WFI, CK_AF will be still selected as system clock. In this case, reset the R240.2 bit to switch back to the crystal oscillator clock.

Bit 0 = **LPOWFI:** Low Power mode during Wait For Interrupt.
0: Low Power mode during WFI disabled. When WFI is executed, the CPUCLK is stopped and INTCLK is unchanged
1: The ST9 enters Low Power mode when the WFI instruction is executed. The clock during this state depends on WFI_CKSEL

VOLTAGE REGULATOR CONTROL REGISTER (VRCTR)

R241 - Read/Write
Register Page: 55
Reset Value: 0000 0x00 (0xh)

7							0
0	0	0	0	VROFF _REG	-	0	0

Bit 7-4 = Reserved, must be kept at 0.
Bit 3 = **VROFF_REG:** Voltage Regulator OFF state. This bit is set and cleared by software.
0: Main Voltage Regulator (VR) on
1: Main VR off. In this state the Main Regulator has zero power consumption, and the PLL is automatically deselected.
This bit must be set for the RTC mode.
Bit 2 = Reserved.
Bit 1-0 = Reserved, must be kept at 0.

CLOCK CONTROL REGISTERS (Cont'd)

CLOCK FLAG REGISTER (CLK_FLAG)

R242 -Read/Write

Register Page: 55

Reset Value: 0110 1000 after a Flash LVD Reset

Reset Value: 0100 1000 after a Watchdog Reset

Reset Value: 0010 1000 after a Software Reset

Reset Value: 0000 1000 after an External Reset

7							0
EX_STP	WDG RES	SOFT RES	XT-STOP	XT_DIV16	CKAF_ST	LO CK	CSU_CK-SEL

WARNING: If you select the CK_AF as system clock and turn off the oscillator (bits R240.2 and R242.4 at 1), in order to switch back to the crystal clock by resetting the R240.2 bit, you must first wait for the oscillator to restart correctly.

Bit 7 = **EX_STP**: *External Stop flag.*

This bit is set by hardware/software and cleared by software.

0: No External Stop condition occurred

1: External Stop condition occurred

Note: This bit is set after the end of the instruction being executed when the microcontroller enters stop mode. So, if this instruction is a reading of the CLK_FLAG register, this bit will still be read as 0. Next reading will give 1 as result.

Bit 6 = **WDGRES**: *Watchdog reset flag.*

This bit is read only.

0: No Watchdog reset occurred

1: Watchdog reset occurred

Bit 5 = **SOFTRES**: *Software Reset Flag.*

This bit is read only.

0: No software reset occurred

1: Software reset occurred (HALT instruction)

If both SOFTRES and WDGRES are set to 1, the last reset event generator was a Flash LVD reset.

Table 28. Reset Flags

WDGRES	SOFTRES	
0	0	External Reset
0	1	Software Reset
1	0	Watchdog Reset
1	1	LVD Reset

Bit 4 = **XTSTOP**: *External Stop Enable.*

0: External stop disabled

1: The Xtal oscillator will be stopped as soon as the CK_AF clock is present and selected, whether this is done explicitly by the user pro-

gram, or as a result of WFI, if WFI_CKSEL has previously been set to select the CK_AF clock during WFI.

Note: When the program writes '1' to the XTSTOP bit, it will still be read as 0 as long as the CKAF_ST bit is reset (CKAF_ST=0). In this case, take care of this behaviour, because a subsequent AND with '1' or a OR with '0' to the XSTOP bit before setting the CKAF_ST bit will prevent the oscillator from being stopped.

Bit 3 = **XT_DIV16**: *CLOCK/16 Selection.*

This bit is set and cleared by software. An interrupt is generated when the bit is toggled.

0: CLOCK2/16 is selected and the PLL is off

1: The input is CLOCK2 (or the PLL output depending on the value of CSU_CKSEL)

Bit 2 = **CKAF_ST**: (Read Only)

If set, indicates that the alternate function clock has been selected. If no clock signal is present on the CK_AF pin, the selection will not occur. If reset, the PLL clock, CLOCK2 or CLOCK2/16 is selected (depending on bit 0).

Bit 1 = **LOCK**: *PLL locked-in*

This bit is read only.

0: The PLL is turned off or not locked and cannot be selected as system clock source.

1: The PLL is locked

Bit 0 = **CSU_CKSEL**: *CSU Clock Select.*

This bit is set and cleared by software. It is also cleared by hardware when:

- bits DX[2:0] (PLLCONF) are set to 111;
- the quartz is stopped (by hardware or software);
- WFI is executed while the LPOWFI bit is set;
- the XT_DIV16 bit (CLK_FLAG) is forced to '0';
- STOP mode is entered.

This prevents the PLL, when not yet locked, from providing an irregular clock. Furthermore, a '0' stored in this bit speeds up the PLL's locking.

0: CLOCK2 provides the system clock

1: The PLL Multiplier provides the system clock if the LOCK bit is set to 1

If the FREEN bit is set, this bit selects this clock independently by the LOCK bit.

NOTE: Setting the CKAF_SEL bit overrides any other clock selection. Resetting the XT_DIV16 bit overrides the CSU_CKSEL selection (see [Figure 61](#)).

CLOCK CONTROL REGISTERS (Cont'd)

PLL CONFIGURATION REGISTER (PLLCONF)

R246 - Read/Write
 Register Page: 55
 Reset Value: 0x00 x111

7							0
FREEN	0	MX1	MX0	0	DX2	DX1	DX0

Bit 7 = **FREEN**: *PLL Free Running Mode Enable*
 0: PLL Free Running Mode disabled
 1: PLL Free Running Mode enabled

When this bit is set, even if the DX[2:0] bits are all set to 1, the PLL is not stopped but provides a slow frequency back-up clock, selectable by the CSU_CKSEL bit of the CLK_FLAG register (without needing to have the LOCK bit equal to '1').

Bits 5:4 = **MX[1:0]**: *PLL Multiplication Factor*.
 Refer to [Table 29](#) for multiplier settings.

WARNING: After these bits are modified, take care that the PLL lock-in time has elapsed before setting the CSU_CKSEL bit in the CLK_FLAG register.

Bits 2:0 = **DX[2:0]**: *PLL output clock divider factor*.
 Refer to [Table 30](#) for divider settings.

Table 29. PLL Multiplication Factors

MX1	MX0	CLOCK2 x
1	0	14
0	0	10
1	1	8
0	1	6

Table 30. PLL Divider Factors

DX2	DX1	DX0	CK
0	0	0	PLL CLOCK/1
0	0	1	PLL CLOCK/2
0	1	0	PLL CLOCK/3
0	1	1	PLL CLOCK/4
1	0	0	PLL CLOCK/5
1	0	1	PLL CLOCK/6
1	1	0	PLL CLOCK/7
1	1	1	CLOCK2 (PLL OFF, Reset State)

Figure 65. RCCU General Timing

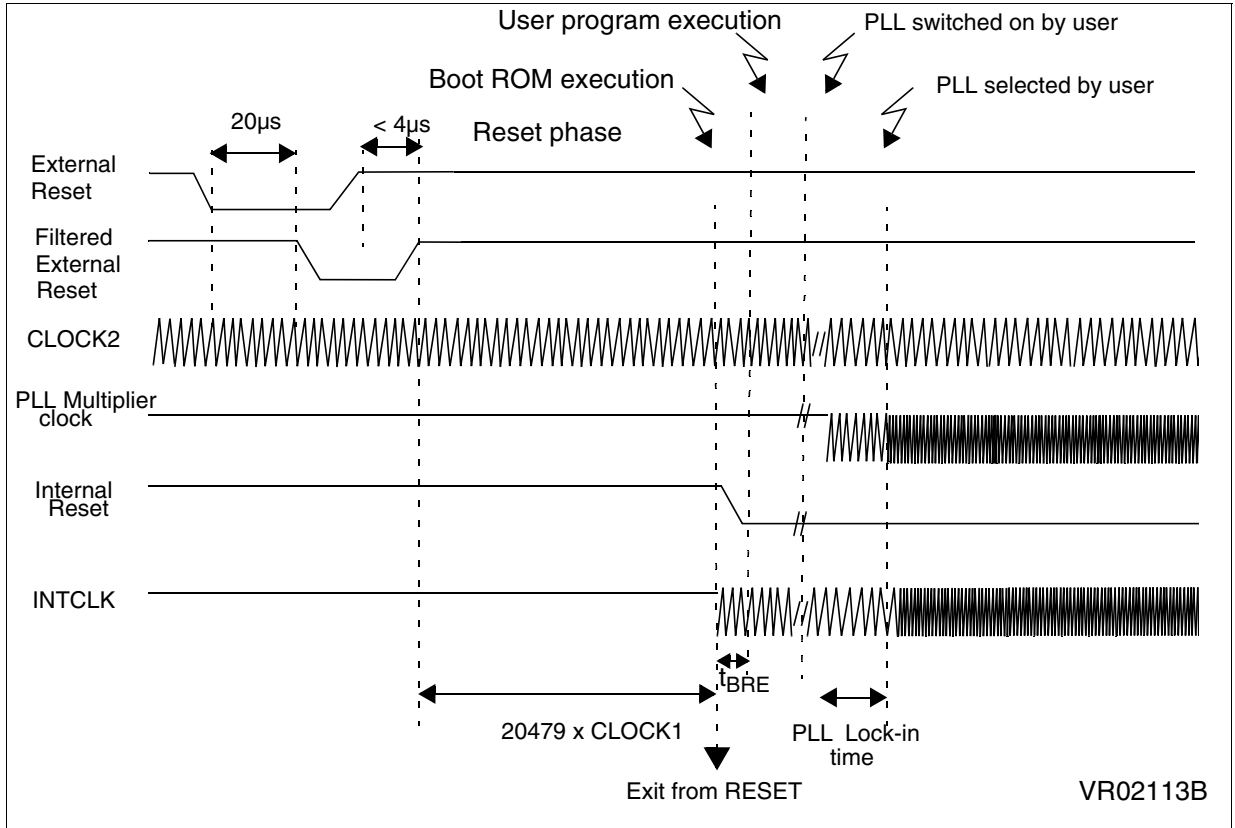

7.5 CRYSTAL OSCILLATOR

The on-chip components for the crystal oscillator are an inverting circuit, polarised at the trip point. The inverter is built around an n-channel transistor, loaded with a current source and polarised through a feedback resistor.

The current source is tailored to obtain a pseudo sinusoidal signal at OSCOUT and OSCIN, reducing the electromagnetic emission. The inverter stage is followed by a matching inverter, which is followed in turn by a schmitt-triggered buffer.

In HALT mode, set by means of the HALT instruction, in STOP mode, and under control of the XT-STOP bit, the oscillator is disabled. The current sources are switched off, reducing the power dissipation. The internal clock, CLOCK1, is forced to a high level.

To exit the HALT condition and restart the oscillator, an external RESET pulse is required, having a minimum duration of T_{STUP} (see Figure 70 and Section 11 ELECTRICAL CHARACTERISTICS).

It should be noted that, if the Watchdog function is enabled, a HALT instruction will not disable the oscillator. This to avoid stopping the Watchdog if a HALT code is executed in error. When this occurs, the CPU will be reset when the Watchdog times out or when an external reset is applied.

Figure 66. Crystal Oscillator

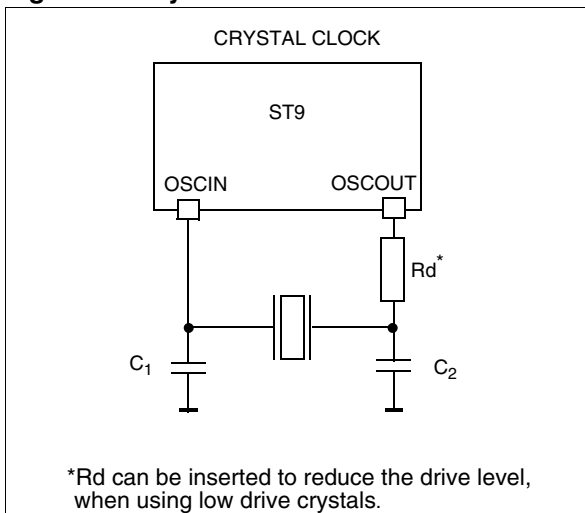

Table 31. Maximum R_S values

C ₁ =C ₂ Freq.	33pF	22pF
5 MHz	80	130
4 MHz	120	200
3 MHz	220	370

Legend:

C₁, C₂: Maximum Total Capacitances on pins OSCIN and OSCOUT (the value includes the external capacitance tied to the pin plus the parasitic capacitance of the board and of the device)

Note: The tables are relative to the fundamental quartz crystal only (not ceramic resonator).

Figure 67. Internal Oscillator Schematic

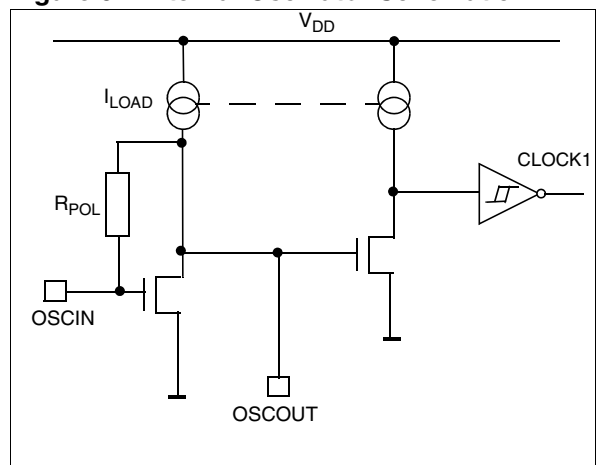
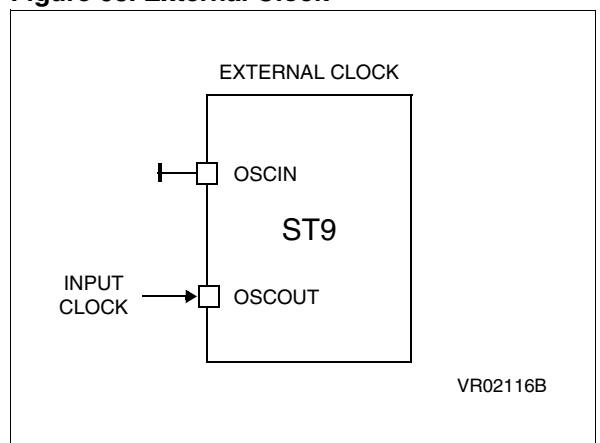

Figure 68. External Clock



CERAMIC RESONATORS

Murata Electronics CERALOCK resonators have been tested with the ST92F150 at 3, 3.68, 4 and 5 MHz. These recommended resonators have built-in capacitors (see Table 32).

The test circuit is shown in Figure 69.

Figure 69. Test Circuit

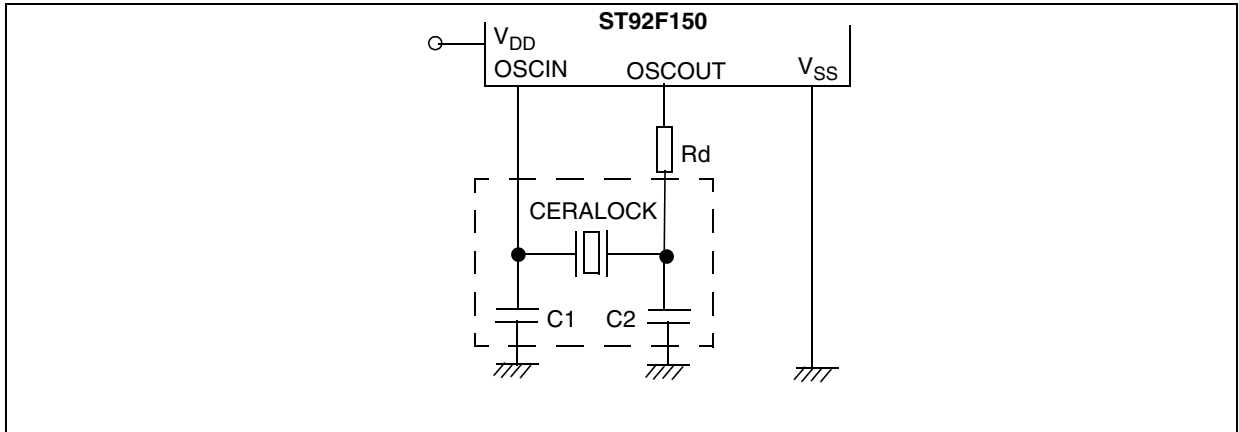

Table 32 shows the recommended conditions at different frequencies.

Table 32. Obtained Results

Freq. (MHz)	Parts Number	C1 (pF)	C2 (pF)	Rd (Ohm)
5	CSTCR5M00G55A-R0	39	39	0
	CSTCC5M00G56A-R0	47	47	0
4	CSTCR4M00G55A-R0	39	39	0
	CSTCC4M00G56A-R0	47	47	0
3	CSTCC3M00G56A-R0	47	47	0
3.68	CSTCC3M68G56A-R0	47	47	0

Advantages of using ceramic resonators:

CSTCR and CSTCC types have built-in loading capacitors.

Smallest loading capacitor resonators are recommended for standard applications.

Highest loading capacitor resonators are recommended for automotive applications with CAN and tight frequency tolerance.

Test conditions:

The evaluation conditions are 4.5 to 5.5 V for the supply voltage and -40° to 105° C for the temperature range.

Caution:

These circuit conditions are for design reference only. Recommended C1, C2 value depends on the circuit board used.

For tight frequency tolerance applications, please contact the nearest Murata office for more detailed PCB evaluation regarding layout.

Note 1:

Attention must be paid to leakage currents around the OSCIN pin. Leakage paths from V_{DD} could alter the DC polarization of the inverter stage and introduce a mismatch with the second stage, and possibly stop the clock signal. It is recommended to surround the oscillator components by a ground ring on the printed circuit board and if necessary to apply a coating film to avoid humidity problems.

Note 2:

Attention must be paid to the capacitive loading of OSCOUT. OSCOUT must not be used to drive external circuits.

7.6 RESET/STOP MANAGER

The Reset/Stop Manager resets the MCU when one of the three following events occurs:

- A Hardware reset, initiated by a low level on the Reset pin.
- A Software reset, initiated by a HALT instruction (when enabled with the SRESEN bit of the CLKCTL register).
- A Watchdog end of count condition.

The event which caused the last Reset is flagged in the CLK_FLAG register, by setting either the

SOFTRES or the WDGRES bit or both; a hardware initiated reset will leave both these bits reset.

The hardware reset overrides all other conditions and forces the ST9 to the reset state. During Reset, the internal registers are set to their reset values (when these reset values are defined, otherwise the register content will remain unchanged), and the I/O pins are set to Bidirectional Weak-Pull-Up or High impedance input. See Section 7.3.

Reset is asynchronous: as soon as the reset pin is driven low, a Reset cycle is initiated.

Figure 70. Oscillator Start-up Sequence and Reset Timing

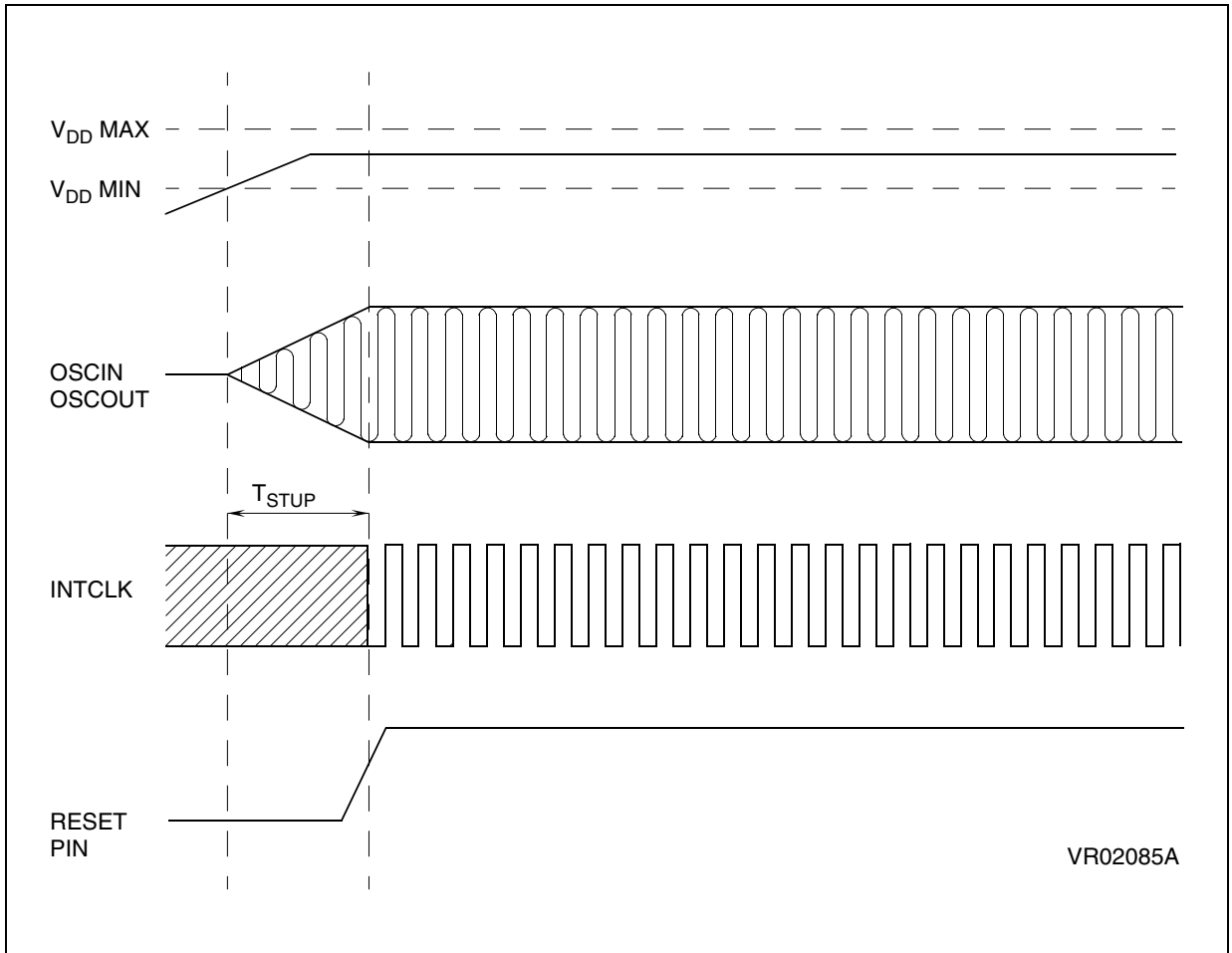

RESET/STOP MANAGER (Cont'd)

The on-chip Timer/Watchdog generates a reset condition if the Watchdog mode is enabled (WCR.WDGEN cleared, R252 page 0), and if the programmed period elapses without the specific code (AAh, 55h) written to the appropriate register. The input pin RESET is not driven low by the on-chip reset generated by the Timer/Watchdog.

When the Reset pin goes high again, 20479 oscillator clock cycles (CLOCK1) are counted before exiting the Reset state (+ one possible CLOCK1 period, depending on the delay between the rising edge of the Reset pin and the first rising edge of CLOCK1). Subsequently a short Boot routine is executed from the device internal Boot memory, and control then passes to the user program.

The Boot routine sets the device characteristics and loads the correct values in the Memory Management Unit's pointer registers, so that these point to the physical memory areas as mapped in the specific device. The precise duration of this short Boot routine varies from device to device, depending on the Boot memory contents.

At the end of the Boot routine the Program Counter will be set to the location specified in the Reset Vector located in the lowest two bytes of memory.

7.6.1 Reset Pin Timing

To improve the noise immunity of the device, the Reset pin has a Schmitt trigger input circuit with hysteresis. In addition, a filter will prevent an unwanted reset in case of a single glitch of less than 50 ns on the Reset pin. The device is certain to reset if a negative pulse of more than 20µs is applied. When the reset pin goes high again, a delay

of up to 4µs will elapse before the RCCU detects this rising front. From this event on, a defined number of CLOCK1 cycles (refer to t_{RSPH}) is counted before exiting the Reset state (+ one possible CLOCK1 period depending on the delay between the positive edge the RCCU detects and the first rising edge of CLOCK1).

If the ST9 is a ROMLESS version, without on-chip program memory, the memory interface ports are set to external memory mode (i.e Alternate Function) and the memory accesses are made to external Program memory with wait cycles insertion.

If the Voltage Regulator is present in the device, please ensure the reset pin is released only when the internal voltage supply is stabilized at 3.3V.

Figure 71. Recommended Signal to be Applied on Reset Pin

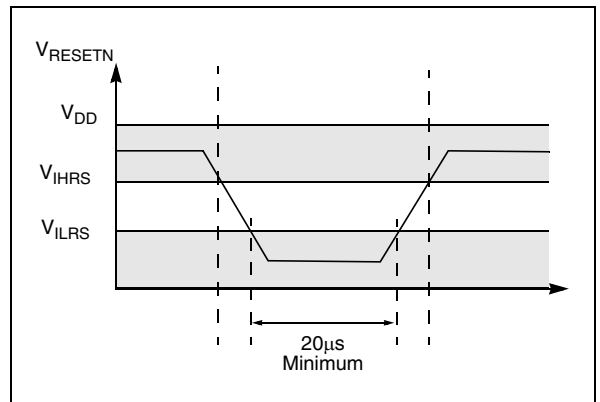
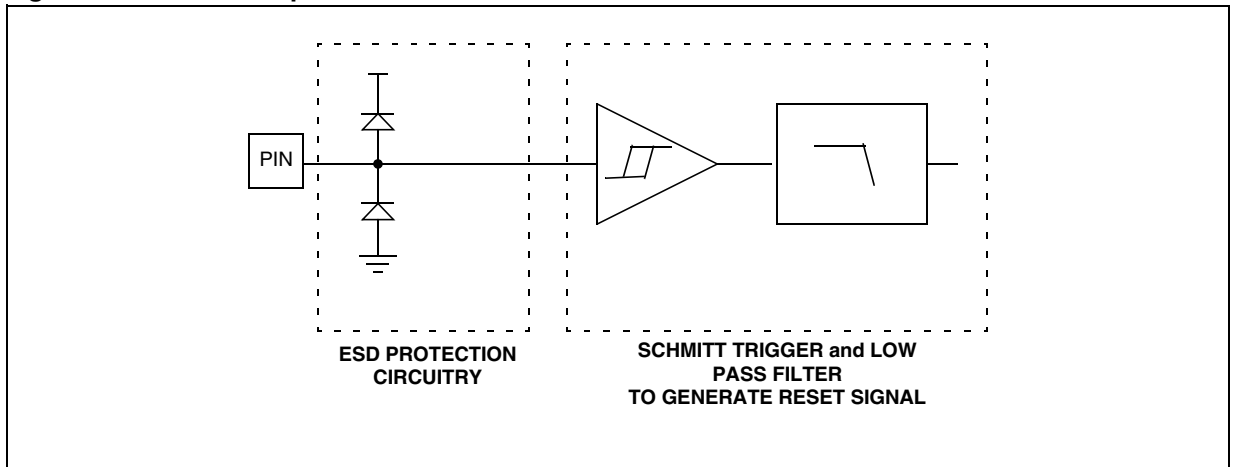

Figure 72. Reset Pin Input Structure



8 EXTERNAL MEMORY INTERFACE (EXTMI)

8.1 INTRODUCTION

The ST9 External Memory Interface uses two registers (EMR1 and EMR2) to configure external memory accesses. Some interface signals are also affected by WCR - R252 Page 0.

If the two registers EMR1 and EMR2 are set to the proper values, the ST9+ memory access cycle is similar to that of the original ST9, with the only exception that it is composed of just two system clock phases, named T1 and T2.

During phase T1, the memory address is output on the \overline{AS} falling edge and is valid on the rising edge of \overline{AS} . Port1 and Port 9 maintain the address stable until the following T1 phase.

During phase T2, two forms of behavior are possible. If the memory access is a Read cycle, Port 0 pins are released in high-impedance until the next T1 phase and the data signals are sampled by the ST9 on the rising edge of \overline{DS} . If the memory access is a Write cycle, on the falling edge of \overline{DS} , Port 0 outputs data to be written in the external memory. Those data signals are valid on the rising edge of \overline{DS} and are maintained stable until the next address is output.

Note that \overline{DS} is pulled low at the beginning of phase T2 only during an external memory access.

Figure 73. Page 21 Registers

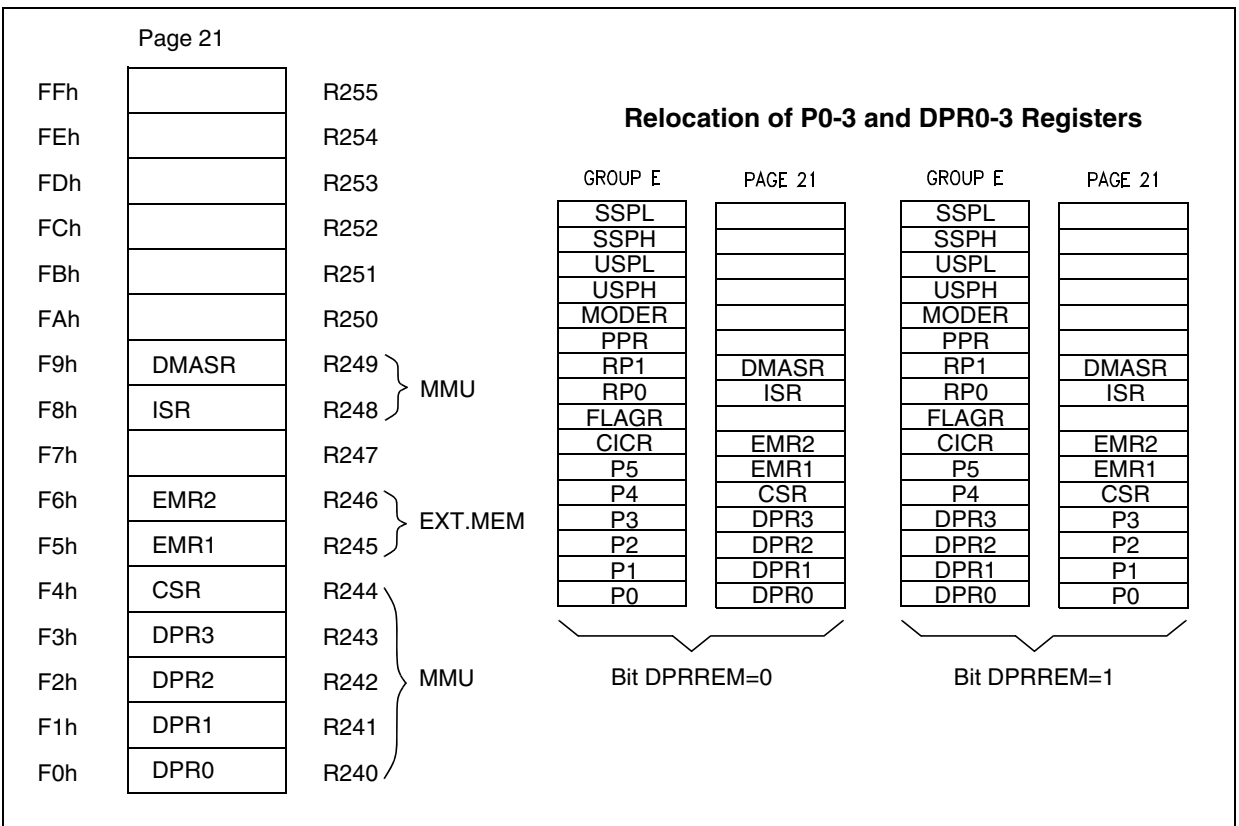

8.2 EXTERNAL MEMORY SIGNALS

The access to external memory is made using the \overline{AS} , \overline{DS} , \overline{RW} , Port 0, Port1, Port9, $\overline{DS2}$ and \overline{WAIT} signals described below.

Refer to [Figure 76](#).

8.2.1 \overline{AS} : Address Strobe

\overline{AS} (Output, Active low, Tristate) is active during the System Clock high-level phase of each T1 memory cycle: an \overline{AS} rising edge indicates that Memory Address and Read/Write Memory control signals are valid.

\overline{AS} is released in high-impedance during the bus acknowledge cycle or under the processor control by setting the HIMP bit (MODER.0, R235).

Under Reset, \overline{AS} is held high with an internal weak pull-up.

The behavior of this signal is also affected by the MC, ASAF, ETO, LAS[1:0] and UAS[1:0] bits in the EMR1 or EMR2 registers. Refer to the Register description.

8.2.2 \overline{DS} : Data Strobe

\overline{DS} (Output, Active low, Tristate) is active during the internal clock high-level phase of each T2 memory cycle. During an external memory read cycle, the data on Port 0 must be valid before the \overline{DS} rising edge. During an external memory write cycle, the data on Port 0 are output on the falling edge of \overline{DS} and they are valid on the rising edge of \overline{DS} . When the internal memory is accessed \overline{DS} is kept high during the whole memory cycle.

\overline{DS} is released in high-impedance during bus acknowledge cycle or under processor control by setting the HIMP bit (MODER.0, R235).

Under Reset status, \overline{DS} is held high with an internal weak pull-up.

The behavior of this signal is also affected by the LDS[2:0], UDS[2:0], DS2EN and MC bits in the

EMR1 or WCR register. Refer to the Register description.

8.2.3 \overline{RW} : Read/Write

\overline{RW} (Output, Active low, Tristate) identifies the type of memory cycle: $\overline{RW}="1"$ identifies a memory read cycle, $\overline{RW}="0"$ identifies a memory write cycle. It is defined at the beginning of each memory cycle and it remains stable until the following memory cycle.

\overline{RW} is released in high-impedance during bus acknowledge cycle or under processor control by setting the HIMP bit (MODER).

Under Reset status, \overline{RW} is held high with an internal weak pull-up.

The behavior of this signal is affected by the MC and ETO bits in the EMR1 register. Refer to the Register description.

8.2.4 $\overline{DS2}$: Data Strobe 2

This additional Data Strobe pin (Alternate Function Output, Active low, Tristate) allows two different external memories to be connected to the ST9, the upper memory block (A21=1 typically RAM) and the lower memory block (A21=0 typically ROM) without any external logic. The selection between the upper and lower memory blocks depends on the A21 address pin value.

The upper memory block is controlled by the \overline{DS} pin while the lower memory block is controlled by the $\overline{DS2}$ pin. When the internal memory is addressed, $\overline{DS2}$ is kept high during the whole memory cycle. $\overline{DS2}$ is enabled via software as the Alternate Function output of the associated I/O port bit.

$\overline{DS2}$ is released in high-impedance during bus acknowledge cycle or under processor control by setting the HIMP bit (MODER.0, r235).

The behavior of this signal is also affected by the DS2EN bit in the EMR1 register. Refer to the Register description.

EXTERNAL MEMORY SIGNALS (Cont'd)

8.2.5 PORT 0

If Port 0 is used as a bit programmable parallel I/O port, it has the same features as a regular port. When set as an Alternate Function, it is used as the External Memory interface: it outputs the multiplexed Address (8 LSB: A[7:0]) / Data bus D[7:0].

8.2.6 PORT 1

If Port 1 is used as a bit programmable parallel I/O port, it has the same features as a regular port. When set as an Alternate Function, it is used as the external memory interface to provide the address bits A[15:8].

8.2.7 PORT 9 [7:2]

If Port 9 is available and used as a bit programmable I/O port, it has the same features as a regular port. If the MMU is available on the device and Port 9 is set as an Alternate Function, Port 9[7:2] is used as the external memory interface to provide the 6 MSB of the address (A[21:16]).

Note: For the ST92F250 device, since A[18:17] share the same pins as SDA1 and SCL1 of I²C_1, these address bits are not available when the I²C_1 is in use (when I2CCR.PE bit is set).

Figure 74. Application Example (MC=0)

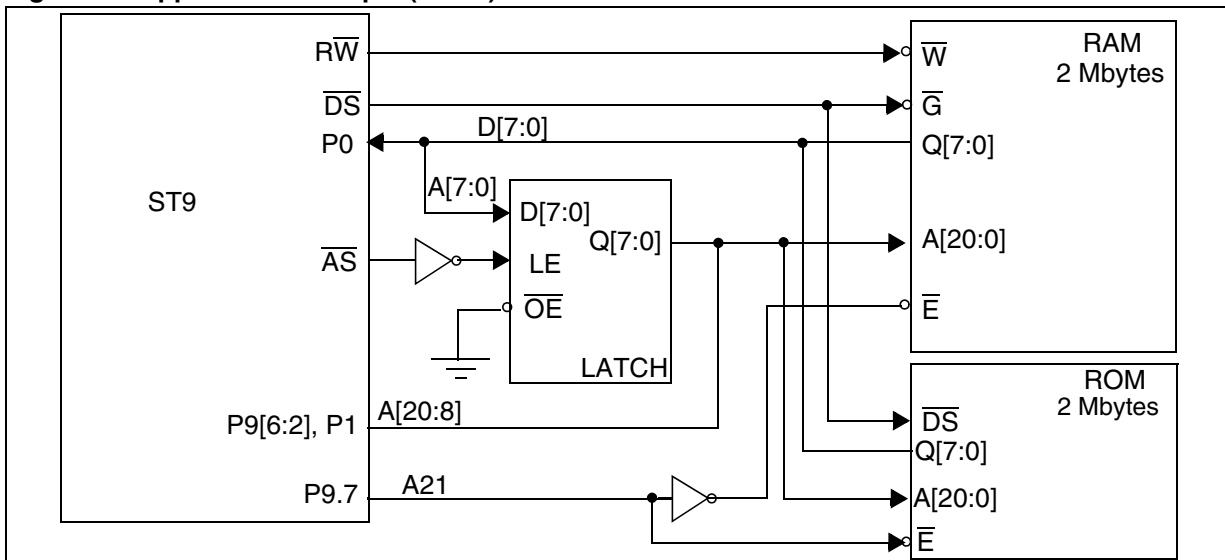
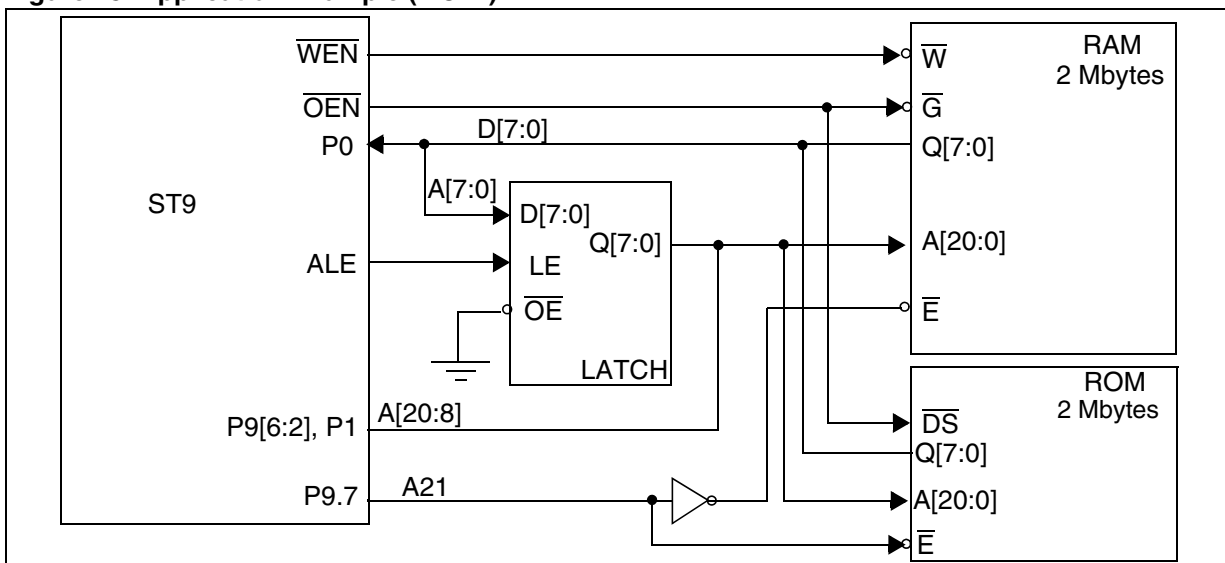
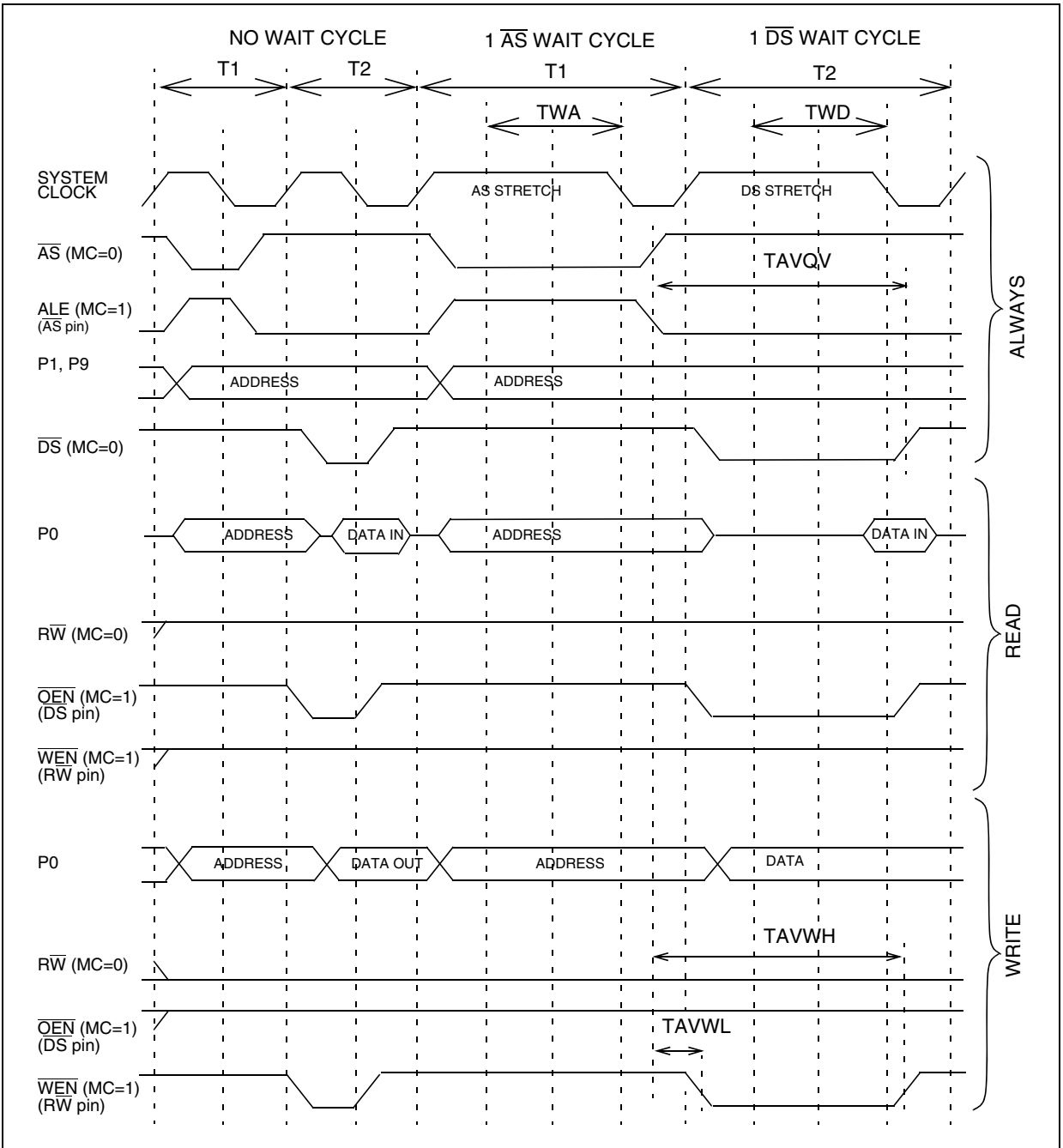

Figure 75. Application Example (MC=1)



EXTERNAL MEMORY SIGNALS (Cont'd)

Figure 76. External memory Read/Write with a programmable wait



EXTERNAL MEMORY SIGNALS (Cont'd)

Figure 77. Effects of DS2EN on the behavior of \overline{DS} and $\overline{DS2}$

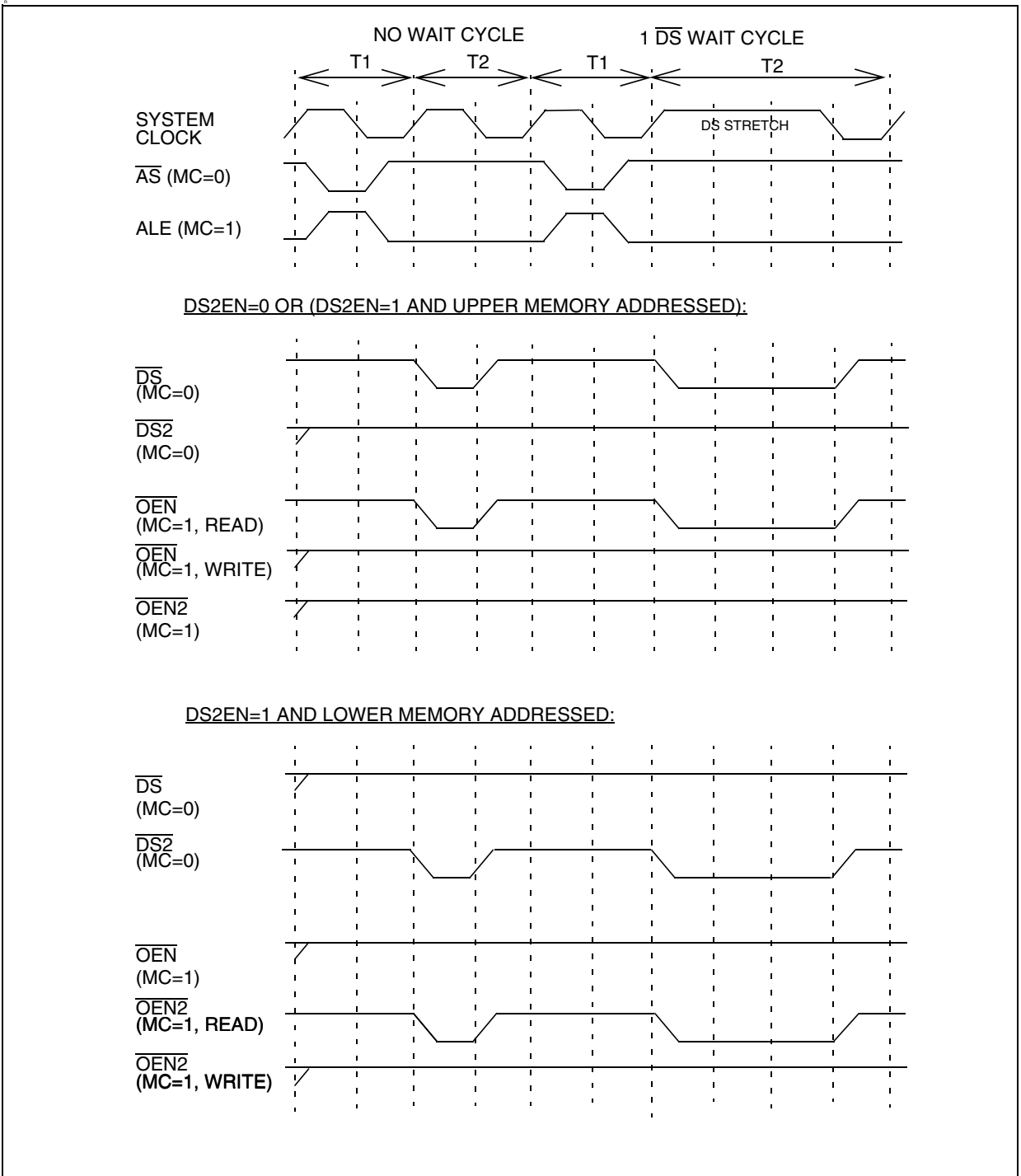

EXTERNAL MEMORY SIGNALS (Cont'd)

8.2.8 $\overline{\text{WAIT}}$: External Memory Wait

$\overline{\text{WAIT}}$ (Alternate Function Input, Active low) indicates to the ST9 that the external memory requires more time to complete the memory access cycle. If bit EWEN (EIVR) is set, the $\overline{\text{WAIT}}$ signal is sampled with the rising edge of the processor internal clock during phase T1 or T2 of every memory cycle. If the signal was sampled active, one more internal clock cycle is added to the memory cycle. On the rising edge of the added internal clock cy-

cle, $\overline{\text{WAIT}}$ is sampled again to continue or finish the memory cycle stretching. Note that if $\overline{\text{WAIT}}$ is sampled active during phase T1 then $\overline{\text{AS}}$ is stretched, while if $\overline{\text{WAIT}}$ is sampled active during phase T2 then $\overline{\text{DS}}$ is stretched. $\overline{\text{WAIT}}$ is enabled via software as the Alternate Function input of the associated I/O port bit (refer to specific ST9 version to identify the specific port and pin). Refer to [Figure 78](#).

Figure 78. External memory Read/Write sequence with external wait request ($\overline{\text{WAIT}}$ pin)

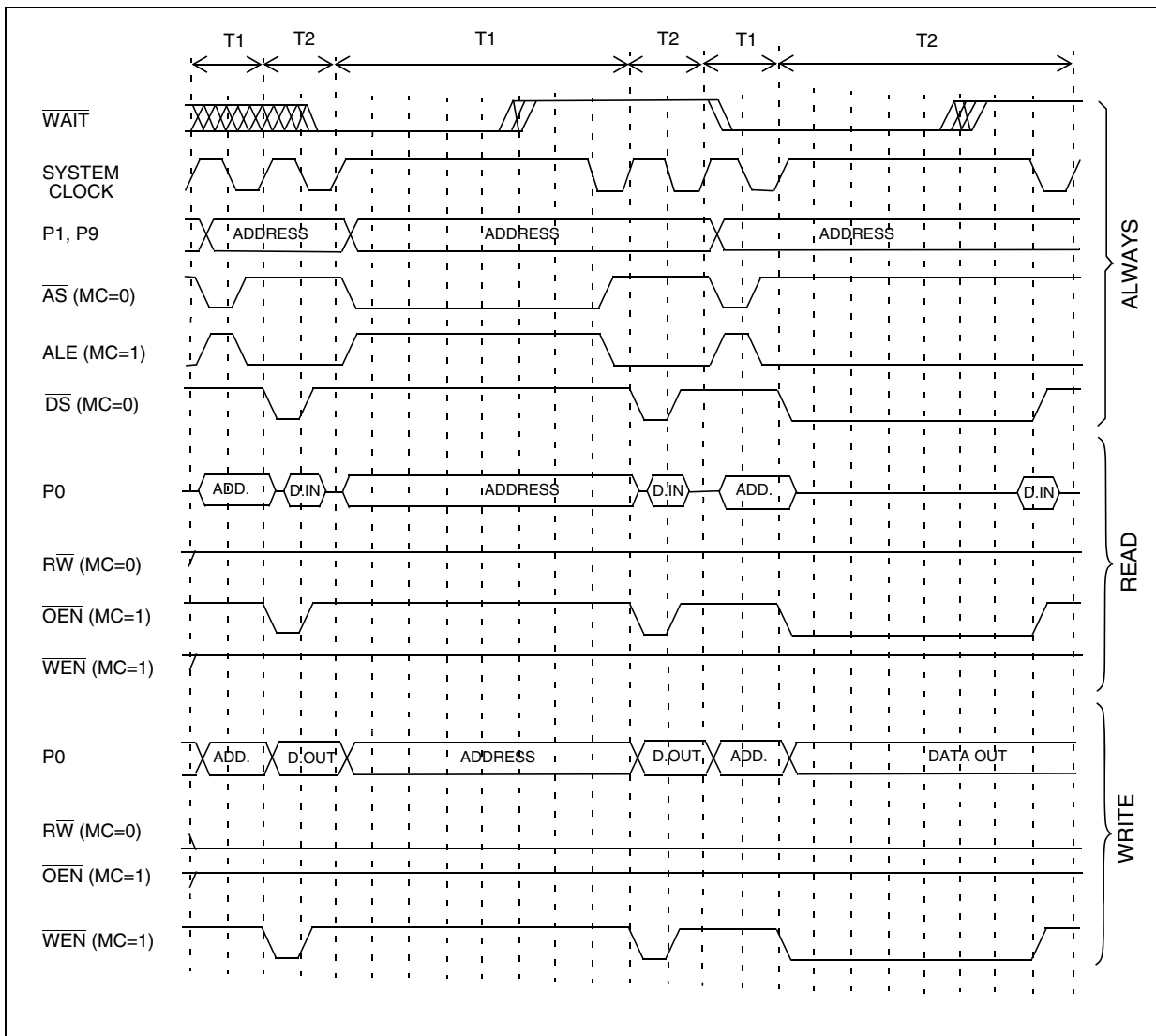

8.3 REGISTER DESCRIPTION

EXTERNAL MEMORY REGISTER 1 (EMR1)

R245 - Read/Write

Register Page: 21

Reset value: 1000 0000 (80h)

7							0
X	MC	DS2EN	ASAF	0	ETO	BSZ	X

Bit 7 = Reserved.

Bit 6 = **MC**: *Mode Control*.

0: \overline{AS} , \overline{DS} and \overline{RW} pins have the standard ST9 format.

1: \overline{AS} pin becomes ALE, Address Load Enable. This signal indicates to the external address latch that a valid address is put on AD[7:0]. When ALE is high, the multiplexed address/data bus AD[7:0] carries the LSBs of the memory address, which must be latched on the falling edge of this signal.

\overline{DS} becomes \overline{OEN} , Output ENable: When this signal is low, the external memory should put the data on the multiplexed address/data bus AD[7:0]. The data is sampled by the microcontroller on the rising edge of the \overline{OEN} signal.

\overline{RW} pin becomes \overline{WEN} , Write ENable: when this signal is low, the multiplexed address/data bus AD[7:0] carries the data to be written in the external memory. The external memory should sample the data on the rising edge of the \overline{WEN} signal.

Bit 5 = **DS2EN**: *Data Strobe 2 enable*.

0: The \overline{DS} pin is active for any external memory access (lower and upper memory block).

The $\overline{DS2}$ pin remains high.

1: If the lower memory block is addressed, the $\overline{DS2}$ pin outputs the standard \overline{DS} signal, while the \overline{DS} pin stays high during the whole memory cycle.

If the upper memory block is addressed, $\overline{DS2}$ is forced to "1" during the whole memory cycle.

Refer to [Figure 77](#)

Bit 4 = **ASAF**: *Address Strobe as Alternate Function*.

Depending on the device, \overline{AS} can be either a dedicated pin or a port Alternate Function. This bit is used only in the second case.

0: \overline{AS} Alternate function disabled.

1: \overline{AS} Alternate Function enabled.

Bit 3 = Reserved, must be kept cleared.

Bit 2 = **ETO**: *External toggle*.

0: The external memory interface pins (\overline{AS} , \overline{DS} , $\overline{DS2}$, \overline{RW} , Port0, Port1, Port9) toggle only if an access to external memory is performed.

1: When the internal memory protection is disabled, the above pins (except \overline{DS} which never toggles during internal memory accesses) toggle during both internal and external memory accesses.

Bit 1 = **BSZ**: *Bus size*.

0: All outputs use the standard low-noise output buffers.

1: P4[7:6], P6[5:4] use high-drive output buffers

Bit 0 = Reserved.

Caution: External memory must be correctly addressed before and after a write operation on the EMR1 register. For example, if code is fetched from external memory using the standard ST9 external memory interface configuration (MC=0), setting the MC bit will cause the device to behave unpredictably.

EXTERNAL MEMORY INTERFACE REGISTERS (Cont'd)

EXTERNAL MEMORY REGISTER 2 (EMR2)

R246 - Read/Write

Register Page: 21

Reset value: 0001 1111 (1Fh)

7							0
-	ENCSR	DPRREM	MEMSEL	LAS1	LAS0	UAS1	UAS0

Bit 7 = Reserved.

Bit 6 = **ENCSR**: *Enable Code Segment Register*.

This bit affects the ST9 CPU behavior whenever an interrupt request is issued.

0: The CPU works in original ST9 compatibility mode concerning stack frame during interrupts. For the duration of the interrupt service routine, ISR is used instead of CSR, and the interrupt stack frame is identical to that of the original ST9: only the PC and Flags are pushed. This avoids saving the CSR on the stack in the event of an interrupt, thus ensuring a faster interrupt response time. The drawback is that it is not possible for an interrupt service routine to perform inter-segment calls or jumps: these instructions would update the CSR, which, in this case, is not used (ISR is used instead). The code segment size for all interrupt service routines is thus limited to 64K bytes.

1: If ENCSR is set, ISR is only used to point to the interrupt vector table and to initialize the CSR at the beginning of the interrupt service routine: the old CSR is pushed onto the stack together with the PC and flags, and CSR is then loaded with

the contents of ISR. In this case, ired will also restore CSR from the stack. This approach allows interrupt service routines to access the entire 4Mbytes of address space; the drawback is that the interrupt response time is slightly increased, because of the need to also save CSR on the stack. Full compatibility with the original ST9 is lost in this case, because the interrupt stack frame is different; this difference, however, should not affect the vast majority of programs.

Bit 5 = **DPRREM**: *Data Page Registers remapping*

0: The locations of the four MMU (Memory Management Unit) Data Page Registers (DPR0, DPR1, DPR2 and DPR3) are in page 21.

1: The four MMU Data Page Registers are swapped with that of the Data Registers of ports 0-3.

Refer to [Figure 73](#)

Bit 4 = **MEMSEL**: *Memory Selection*.

Warning: Must be kept at 1.

Bit 3:2 = **LAS[1:0]**: *Lower memory address strobe stretch*.

These two bits contain the number of wait cycles (from 0 to 3) to add to the System Clock to stretch \overline{AS} during external lower memory block accesses (A21="0"). The reset value is 3.

EXTERNAL MEMORY INTERFACE REGISTERS (Cont'd)

Bit 1:0 = **UAS[1:0]**: *Upper memory address strobe stretch.*

These two bits contain the number of wait cycles (from 0 to 3) to add to the System Clock to stretch AS during external upper memory block accesses (A21=1). The reset value is 3.

Caution: The EMR2 register cannot be written during an interrupt service routine.

WAIT CONTROL REGISTER (WCR)

R252 - Read/Write

Register Page: 0

Reset Value: 0111 1111 (7Fh)

7							0
0	WDGEN	UDS2	UDS1	UDS0	LDS2	LDS1	LDS0

Bit 7 = Reserved, forced by hardware to 0.

Bit 6 = **WDGEN**: *Watchdog Enable.*

For a description of this bit, refer to the Timer/Watchdog chapter.

Caution: Clearing this bit has the effect of setting the Timer/Watchdog to Watchdog mode. Unless this is desired, it must be set to "1".

Bit 5:3 = **UDS[2:0]**: *Upper memory data strobe stretch.*

These bits contain the number of INTCLK cycles to be added automatically to DS for external upper

memory block accesses. UDS = 0 adds no additional wait cycles. UDS = 7 adds the maximum 7 INTCLK cycles (reset condition).

Bit 2:0 = **LDS[2:0]**: *Lower memory data strobe stretch.*

These bits contain the number of INTCLK cycles to be added automatically to DS for external lower memory block accesses. LDS = 0 adds no additional wait cycles, LDS = 7 adds the maximum 7 INTCLK cycles (reset condition).

Note 1: The number of clock cycles added refers to INTCLK and NOT to CPUCLK.

Note 2: The distinction between the Upper memory block and the Lower memory block allows different wait cycles between the first 2 Mbytes and the second 2 Mbytes, and allows 2 different data strobe signals to be used to access 2 different memories.

Typically, the RAM will be located above address 0x200000 and the ROM below address 0x1FFFFFF, with different access times (see [Figure 74](#)).

Caution: The reset value of the Wait Control Register gives the maximum number of Wait cycles for external memory. To get optimum performance from the ST9, the user should write the UDS[2:0] and LDS[2:0] bits to 0, if the external addressed memories are fast enough.

9 I/O PORTS

9.1 INTRODUCTION

ST9 devices feature flexible individually programmable multifunctional input/output lines. Refer to the Pin Description Chapter for specific pin allocations. These lines, which are logically grouped as 8-bit ports, can be individually programmed to provide digital input/output and analog input, or to connect input/output signals to the on-chip peripherals as alternate pin functions. All ports can be individually configured as an input, bi-directional, output or alternate function. In addition, pull-ups can be turned off for open-drain operation, and weak pull-ups can be turned on in their place, to avoid the need for off-chip resistive pull-ups. Ports configured as open drain must never have voltage on the port pin exceeding V_{DD} (refer to the Electrical Characteristics section). Depending on the specific port, input buffers are software selectable to be TTL or CMOS compatible, however on Schmitt trigger ports, no selection is possible.

9.2 SPECIFIC PORT CONFIGURATIONS

Refer to the Pin Description chapter for a list of the specific port styles and reset values.

9.3 PORT CONTROL REGISTERS

Each port is associated with a Data register (PxDR) and three Control registers (PxC0, PxC1, PxC2). These define the port configuration and allow dynamic configuration changes during program execution. Port Data and Control registers are mapped into the Register File as shown in [Figure 79](#). Port Data and Control registers are treated just like any other general purpose register. There are no special instructions for port manipulation: any instruction that can address a register, can address the ports. Data can be directly accessed in the port register, without passing through other memory or “accumulator” locations.

Figure 79. I/O Register Map

GROUP E			GROUP F PAGE 2			GROUP F PAGE 3			GROUP F PAGE 43		
			FFh	Reserved		P7DR		P9DR		R255	
			FEh	P3C2		P7C2		P9C2		R254	
			FDh	P3C1		P7C1		P9C1		R253	
			FCh	P3C0		P7C0		P9C0		R252	
			FBh	Reserved		P6DR		P8DR		R251	
			FAh	P2C2		P6C2		P8C2		R250	
			F9h	P2C1		P6C1		P8C1		R249	
			F8h	P2C0		P6C0		P8C0		R248	
			F7h	Reserved		Reserved				R247	
			F6h	P1C2		P5C2				R246	
E5h	P5DR	R229	F5h	P1C1		P5C1				R245	
E4h	P4DR	R228	F4h	P1C0		P5C0		Reserved		R244	
E3h	P3DR	R227	F3h	Reserved		Reserved				R243	
E2h	P2DR	R226	F2h	P0C2		P4C2				R242	
E1h	P1DR	R225	F1h	P0C1		P4C1				R241	
E0h	P0DR	R224	F0h	P0C0		P4C0				R240	

PORT CONTROL REGISTERS (Cont'd)

During Reset, ports with weak pull-ups are set in bidirectional/weak pull-up mode and the output Data Register is set to FFh. This condition is also held after Reset, except for Ports 0 and 1 in ROM-less devices, and can be redefined under software control.

Bidirectional ports without weak pull-ups are set in high impedance during reset. To ensure proper levels during reset, these ports must be externally connected to either V_{DD} or V_{SS} through external pull-up or pull-down resistors.

Other reset conditions may apply in specific ST9 devices.

9.4 INPUT/OUTPUT BIT CONFIGURATION

By programming the control bits $PxC0.n$ and $PxC1.n$ (see [Figure 80](#)) it is possible to configure bit $Px.n$ as Input, Output, Bidirectional or Alternate Function Output, where X is the number of the I/O port, and n the bit within the port ($n = 0$ to 7).

When programmed as input, it is possible to select the input level as TTL or CMOS compatible by programming the relevant $PxC2.n$ control bit.

This option is not available on Schmitt trigger ports.

The output buffer can be programmed as push-pull or open-drain.

A weak pull-up configuration can be used to avoid external pull-ups when programmed as bidirectional (except where the weak pull-up option has been permanently disabled in the pin hardware assignment).

Each pin of an I/O port may assume software programmable Alternate Functions (refer to the device Pin Description and to Section 9.5 ALTERNATE FUNCTION ARCHITECTURE). To output signals from the ST9 peripherals, the port must be configured as AF OUT. On ST9 devices with A/D Converter(s), configure the ports used for analog inputs as AF IN.

The basic structure of the bit $Px.n$ of a general purpose port Px is shown in [Figure 81](#).

Independently of the chosen configuration, when the user addresses the port as the destination register of an instruction, the port is written to and the data is transferred from the internal Data Bus to the Output Master Latches. When the port is addressed as the source register of an instruction, the port is read and the data (stored in the Input Latch) is transferred to the internal Data Bus.

When $Px.n$ is programmed as an Input:
(See [Figure 82](#)).

- The Output Buffer is forced tristate.
- The data present on the I/O pin is sampled into the Input Latch at the beginning of each instruction execution.
- The data stored in the Output Master Latch is copied into the Output Slave Latch at the end of the execution of each instruction. Thus, if bit $Px.n$ is reconfigured as an Output or Bidirectional, the data stored in the Output Slave Latch will be reflected on the I/O pin.

INPUT/OUTPUT BIT CONFIGURATION (Cont'd)

Figure 80. Control Bits

	Bit 7				Bit n				Bit 0
PxC2	PxC27				PxC2n				PxC20
PxC1	PxC17				PxC1n				PxC10
PxC0	PxC07				PxC0n				PxC00

Table 33. Port Bit Configuration Table (n = 0, 1... 7; X = port number)

	General Purpose I/O Pins								A/D Pins
PXC2n	0	1	0	1	0	1	0	1	1
PXC1n	0	0	1	1	0	0	1	1	1
PXC0n	0	0	0	0	1	1	1	1	1
PXn Configuration	BID	BID	OUT	OUT	IN	IN	AF OUT	AF OUT	AF IN
PXn Output Type	WP OD	OD	PP	OD	HI-Z	HI-Z	PP	OD	HI-Z ⁽¹⁾
PXn Input Type	TTL (or Schmitt Trigger)	TTL (or Schmitt Trigger)	TTL (or Schmitt Trigger)	TTL (or Schmitt Trigger)	CMOS (or Schmitt Trigger)	TTL (or Schmitt Trigger)	TTL (or Schmitt Trigger)	TTL (or Schmitt Trigger)	Analog Input

⁽¹⁾ For A/D Converter inputs.

Legend:

X = Port
n = Bit
AF = Alternate Function
BID = Bidirectional
CMOS= CMOS Standard Input Levels
HI-Z = High Impedance
IN = Input
OD = Open Drain
OUT = Output
PP = Push-Pull
TTL = TTL Standard Input Levels
WP = Weak Pull-up

INPUT/OUTPUT BIT CONFIGURATION (Cont'd)

Figure 81. Basic Structure of an I/O Port Pin

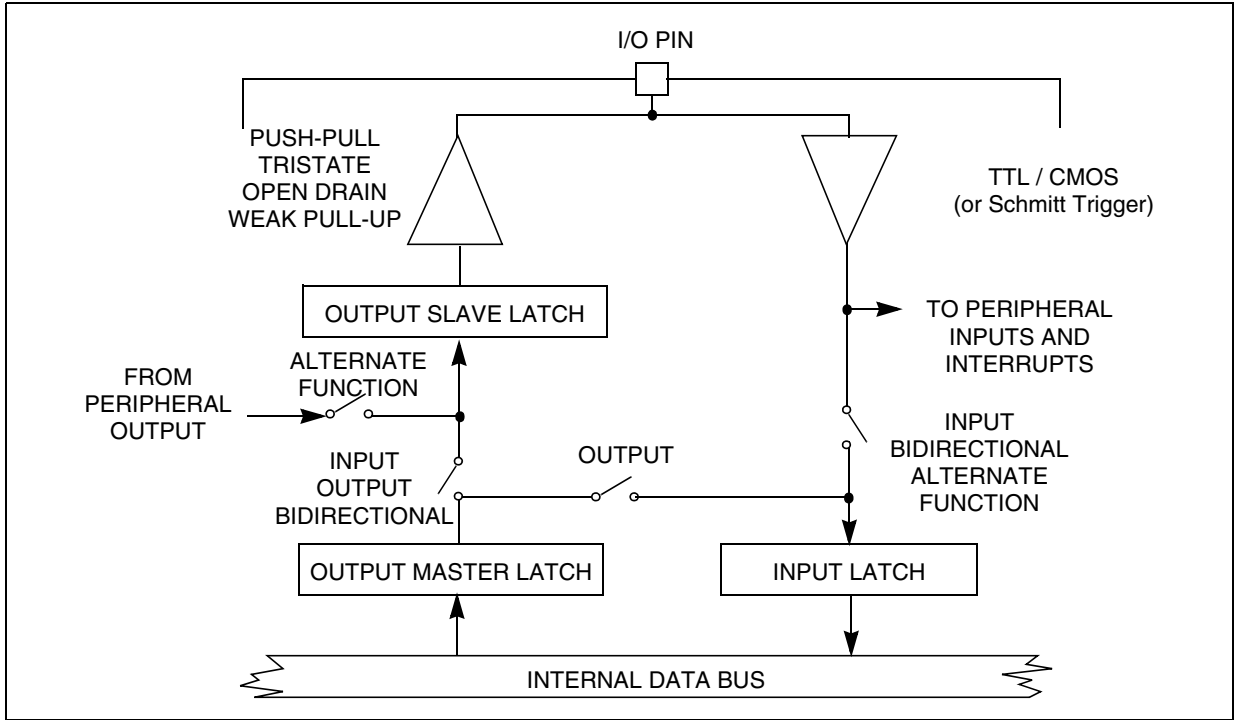

Figure 82. Input Configuration

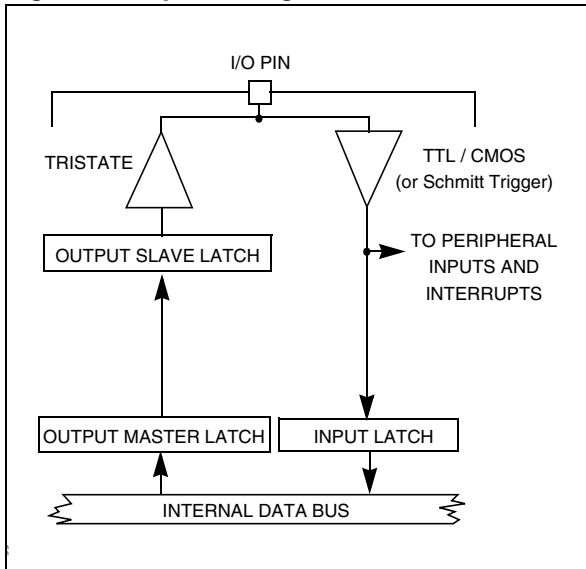
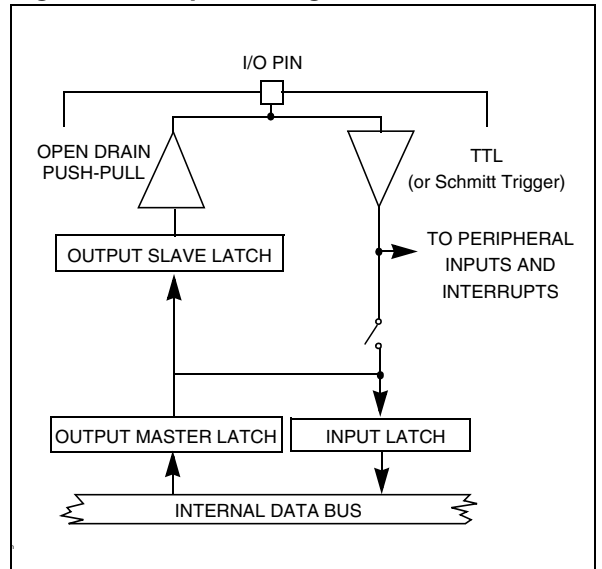

Figure 83. Output Configuration



INPUT/OUTPUT BIT CONFIGURATION (Cont'd)**When Px.n is programmed as an Output:**
(Figure 83)

- The Output Buffer is turned on in an Open-drain or Push-pull configuration.
- The data stored in the Output Master Latch is copied both into the Input Latch and into the Output Slave Latch, driving the I/O pin, at the end of the execution of the instruction.

When Px.n is programmed as Bidirectional:
(Figure 84)

- The Output Buffer is turned on in an Open-Drain or Weak Pull-up configuration (except when disabled in hardware).
- The data present on the I/O pin is sampled into the Input Latch at the beginning of the execution of the instruction.
- The data stored in the Output Master Latch is copied into the Output Slave Latch, driving the I/O pin, at the end of the execution of the instruction.

WARNING: Due to the fact that in bidirectional mode the external pin is read instead of the output latch, particular care must be taken with arithmetic/logic and Boolean instructions performed on a bidirectional port pin.

These instructions use a read-modify-write sequence, and the result written in the port register depends on the logical level present on the external pin.

This may bring unwanted modifications to the port output register content.

For example:

Port register content, 0Fh
external port value, 03h
(Bits 3 and 2 are externally forced to 0)

A `bset` instruction on bit 7 will return:

Port register content, 83h
external port value, 83h
(Bits 3 and 2 have been cleared).

To avoid this situation, it is suggested that all operations on a port, using at least one bit in bidirectional mode, are performed on a copy of the port register, then transferring the result with a load instruction to the I/O port.

When Px.n is programmed as a digital Alternate Function Output:
(Figure 85)

- The Output Buffer is turned on in an Open-Drain or Push-Pull configuration.

- The data present on the I/O pin is sampled into the Input Latch at the beginning of the execution of the instruction.
- The signal from an on-chip function is allowed to load the Output Slave Latch driving the I/O pin. Signal timing is under control of the alternate function. If no alternate function is connected to Px.n, the I/O pin is driven to a high level when in Push-Pull configuration, and to a high impedance state when in open drain configuration.

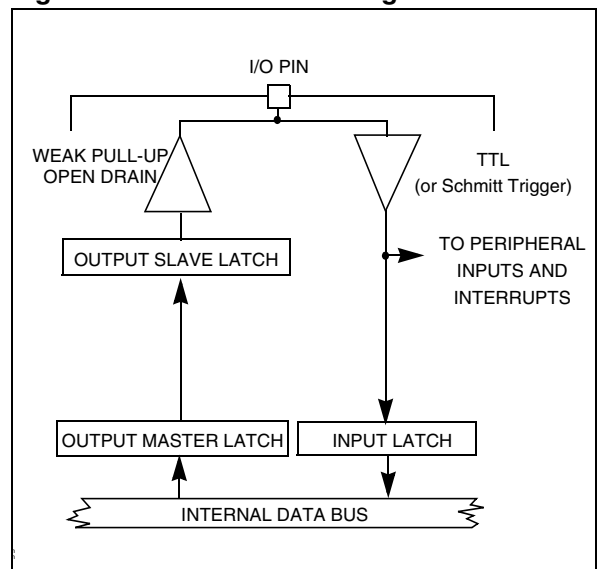
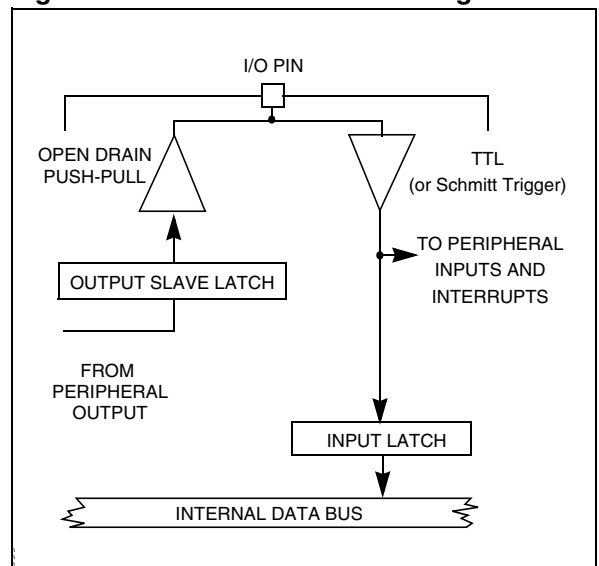
Figure 84. Bidirectional Configuration**Figure 85. Alternate Function Configuration**

9.5 ALTERNATE FUNCTION ARCHITECTURE

Each I/O pin may be connected to three different types of internal signal:

- Data bus Input/Output
- Alternate Function Input
- Alternate Function Output

9.5.1 Pin Declared as I/O

A pin declared as I/O, is connected to the I/O buffer. This pin may be an Input, an Output, or a bidirectional I/O, depending on the value stored in (PxC2, PxC1 and PxC0).

9.5.2 Pin Declared as an Alternate Function Input

A single pin may be directly connected to several Alternate Function inputs. In this case, the user must select the required input mode (with the PxC2, PxC1, PxC0 bits) and enable the selected Alternate Function in the Control Register of the peripheral. No specific port configuration is required to enable an Alternate Function input, since the input buffer is directly connected to each alternate function module on the shared pin. As more than one module can use the same input, it is up to the user software to enable the required module as necessary. Parallel I/Os remain operational even when using an Alternate Function input. The exception to this is when an I/O port bit is permanently assigned by hardware as an A/D bit. In this case, after software programming of the bit in AFOD-TTL, the Alternate function output is forced to logic level 1. The analog voltage level on the corresponding pin is directly input to the A/D (See Figure 86).

Figure 86. A/D Input Configuration

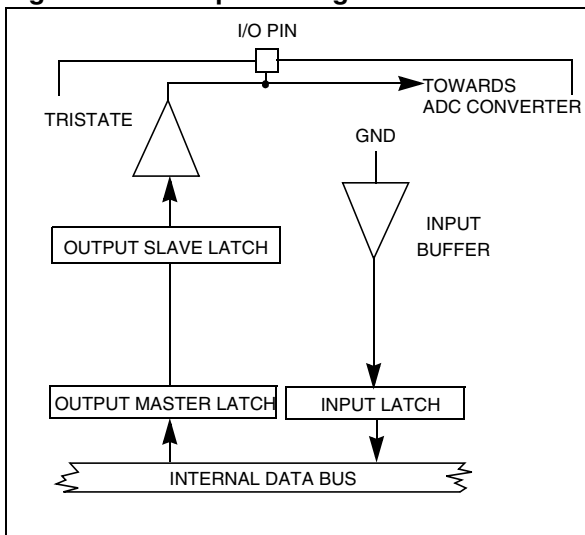

9.5.3 Pin Declared as an Alternate Function Output

The user must select the AF OUT configuration using the PxC2, PxC1, PxC0 bits. Several Alternate Function outputs may drive a common pin. In such case, the Alternate Function output signals are logically ANDed before driving the common pin. The user must therefore enable the required Alternate Function Output by software.

WARNING: When a pin is connected both to an alternate function output and to an alternate function input, it should be noted that the output signal will always be present on the alternate function input.

9.6 I/O STATUS AFTER WFI, HALT AND RESET

The status of the I/O ports during the Wait For Interrupt, Halt and Reset operational modes is shown in the following table. The External Memory Interface ports are shown separately. If only the internal memory is being used and the ports are acting as I/O, the status is the same as shown for the other I/O ports.

Mode	Ext. Mem - I/O Ports		I/O Ports
	P0	P1, P2, P6, P9[7:2] *	
WFI	High Impedance or next address (depending on the last memory operation performed on Port)	Next Address	Not Affected (clock outputs running)
HALT	High Impedance	Next Address	Not Affected (clock outputs stopped)
RESET	Alternate function push-pull (ROMless device)		Bidirectional Weak Pull-up (High impedance when disabled in hardware).

* Depending on device

10 ON-CHIP PERIPHERALS

10.1 TIMER/WATCHDOG (WDT)

Important Note: This chapter is a generic description of the WDT peripheral. However depending on the ST9 device, some or all of WDT interface signals described may not be connected to external pins. For the list of WDT pins present on the ST9 device, refer to the device pinout description in the first section of the data sheet.

10.1.1 Introduction

The Timer/Watchdog (WDT) peripheral consists of a programmable 16-bit timer and an 8-bit prescaler. It can be used, for example, to:

- Generate periodic interrupts
- Measure input signal pulse widths
- Request an interrupt after a set number of events
- Generate an output signal waveform
- Act as a Watchdog timer to monitor system integrity

The main WDT registers are:

- Control register for the input, output and interrupt logic blocks (WDTCCR)
- 16-bit counter register pair (WDTHR, WDTLR)
- Prescaler register (WDTPR)

The hardware interface consists of up to five signals:

- WDIN External clock input
- WDOOUT Square wave or PWM signal output
- INT0 External interrupt input
- NMI Non-Maskable Interrupt input
- HW0SW1 Hardware/Software Watchdog enable.

Figure 87. Timer/Watchdog Block Diagram

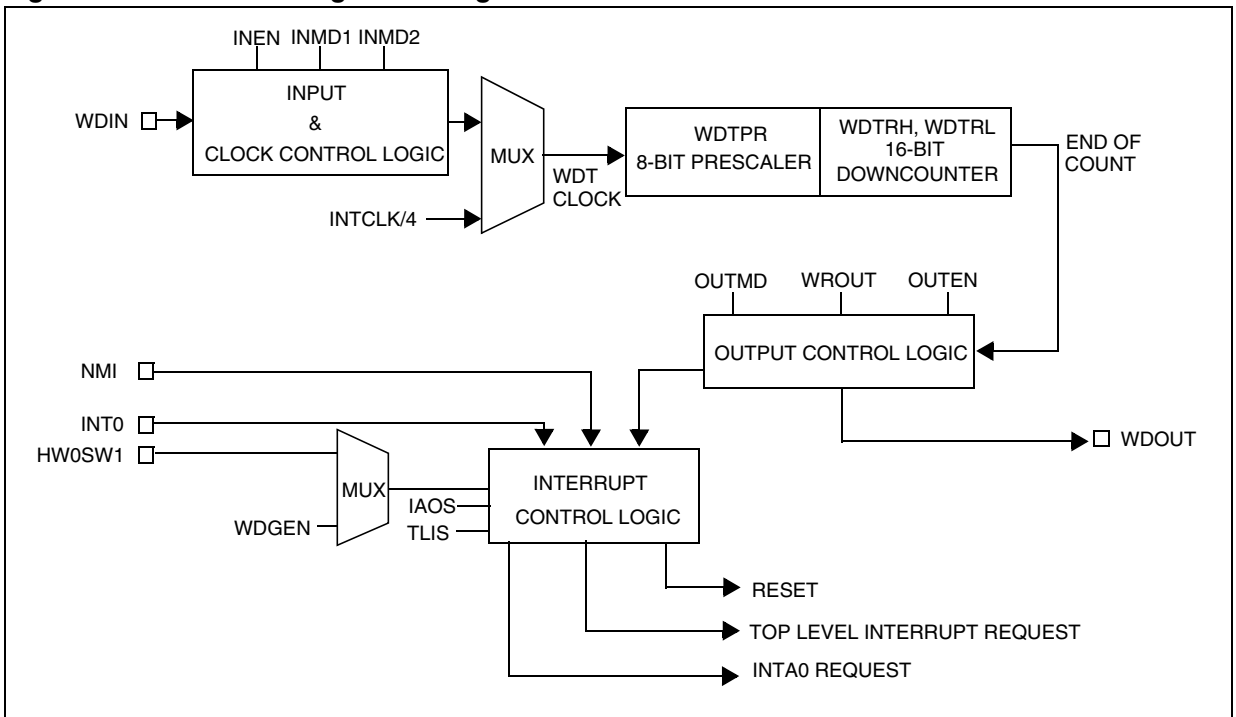

TIMER/WATCHDOG (Cont'd)

10.1.2 Functional Description

10.1.2.1 External Signals

The HW0SW1 pin can be used to permanently enable Watchdog mode. Refer to [Section 10.1.3.1 on page 159](#).

The WDIN Input pin can be used in one of four modes:

- Event Counter Mode
- Gated External Input Mode
- Triggerable Input Mode
- Retriggerable Input Mode

The WDOOUT output pin can be used to generate a square wave or a Pulse Width Modulated signal.

An interrupt, generated when the WDT is running as the 16-bit Timer/Counter, can be used as a Top Level Interrupt or as an interrupt source connected to channel A0 of the external interrupt structure (replacing the INT0 interrupt input).

The counter can be driven either by an external clock, or internally by INTCLK divided by 4.

10.1.2.2 Initialisation

The prescaler (WDTPR) and counter (WDTL, WDTRH) registers must be loaded with initial values before starting the Timer/Counter. If this is not done, counting will start with reset values.

10.1.2.3 Start/Stop

The ST_SP bit enables downcounting. When this bit is set, the Timer will start at the beginning of the following instruction. Resetting this bit stops the counter.

If the counter is stopped and restarted, counting will resume from the last value unless a new constant has been entered in the Timer registers (WDTL, WDTRH).

A new constant can be written in the WDTRH, WDTL, WDTPR registers while the counter is running. The new value of the WDTRH, WDTL registers will be loaded at the next End of Count (EOC) condition while the new value of the WDTPR register will be effective immediately.

End of Count is when the counter is 0.

When Watchdog mode is enabled the state of the ST_SP bit is irrelevant.

10.1.2.4 Single/Continuous Mode

The S_C bit allows selection of single or continuous mode. This Mode bit can be written with the Timer stopped or running. It is possible to toggle the S_C bit and start the counter with the same instruction.

Single Mode

On reaching the End Of Count condition, the Timer stops, reloads the constant, and resets the Start/Stop bit. Software can check the current status by reading this bit. To restart the Timer, set the Start/Stop bit.

Note: If the Timer constant has been modified during the stop period, it is reloaded at start time.

Continuous Mode

On reaching the End Of Count condition, the counter automatically reloads the constant and restarts. It is stopped only if the Start/Stop bit is reset.

10.1.2.5 Input Section

If the Timer/Counter input is enabled (INEN bit) it can count pulses input on the WDIN pin. Otherwise it counts the internal clock/4.

For instance, when INTCLK = 24MHz, the End Of Count rate is:

2.79 seconds for Maximum Count
(Timer Const. = FFFFh, Prescaler Const. = FFh)

166 ns for Minimum Count
(Timer Const. = 0000h, Prescaler Const. = 00h)

The Input pin can be used in one of four modes:

- Event Counter Mode
- Gated External Input Mode
- Triggerable Input Mode
- Retriggerable Input Mode

The mode is configurable in the WDTCR.

10.1.2.6 Event Counter Mode

In this mode the Timer is driven by the external clock applied to the input pin, thus operating as an event counter. The event is defined as a high to low transition of the input signal. Spacing between trailing edges should be at least 8 INTCLK periods (or 333ns with INTCLK = 24MHz).

Counting starts at the next input event after the ST_SP bit is set and stops when the ST_SP bit is reset.

TIMER/WATCHDOG (Cont'd)

10.1.2.7 Gated Input Mode

This mode can be used for pulse width measurement. The Timer is clocked by INTCLK/4, and is started and stopped by means of the input pin and the ST_SP bit. When the input pin is high, the Timer counts. When it is low, counting stops. The maximum input pin frequency is equivalent to INTCLK/8.

10.1.2.8 Triggerable Input Mode

The Timer (clocked internally by INTCLK/4) is started by the following sequence:

- setting the Start-Stop bit, followed by
- a High to Low transition on the input pin.

To stop the Timer, reset the ST_SP bit.

10.1.2.9 Retriggerable Input Mode

In this mode, the Timer (clocked internally by INTCLK/4) is started by setting the ST_SP bit. A High to Low transition on the input pin causes counting to restart from the initial value. When the Timer is stopped (ST_SP bit reset), a High to Low transition of the input pin has no effect.

10.1.2.10 Timer/Counter Output Modes

Output modes are selected by means of the OUTEN (Output Enable) and OUTMD (Output Mode) bits of the WDTCCR register.

No Output Mode
(OUTEN = “0”)

The output is disabled and the corresponding pin is set high, in order to allow other alternate functions to use the I/O pin.

Square Wave Output Mode
(OUTEN = “1”, OUTMD = “0”)

The Timer outputs a signal with a frequency equal to half the End of Count repetition rate on the WDOUT pin. With an INTCLK frequency of 20MHz, this allows a square wave signal to be generated whose period can range from 400ns to 6.7 seconds.

Pulse Width Modulated Output Mode
(OUTEN = “1”, OUTMD = “1”)

The state of the WROUT bit is transferred to the output pin (WDOUT) at the End of Count, and is held until the next End of Count condition. The user can thus generate PWM signals by modifying the status of the WROUT pin between End of Count events, based on software counters decremented by the Timer Watchdog interrupt.

10.1.3 Watchdog Timer Operation

This mode is used to detect the occurrence of a software fault, usually generated by external interference or by unforeseen logical conditions, which causes the application program to abandon its normal sequence of operation. The Watchdog, when enabled, resets the MCU, unless the program executes the correct write sequence before expiry of the programmed time period. The application program must be designed so as to correctly write to the WDTLR Watchdog register at regular intervals during all phases of normal operation.

10.1.3.1 Hardware Watchdog/Software Watchdog

The HW0SW1 pin (when available) selects Hardware Watchdog or Software Watchdog.

If HW0SW1 is held low:

- The Watchdog is enabled by hardware immediately after an external reset. (Note: Software reset or Watchdog reset have no effect on the Watchdog enable status).
- The initial counter value (FFFFh) cannot be modified, however software can change the prescaler value on the fly.
- The WDGEN bit has no effect. (Note: it is not forced low).

If HW0SW1 is held high, or is not present:

- The Watchdog can be enabled by resetting the WDGEN bit.

10.1.3.2 Starting the Watchdog

In Watchdog mode the Timer is clocked by INTCLK/4.

If the Watchdog is software enabled, the time base must be written in the timer registers before entering Watchdog mode by resetting the WDGEN bit. Once reset, this bit cannot be changed by software.

If the Watchdog is hardware enabled, the time base is fixed by the reset value of the registers.

Resetting WDGEN causes the counter to start, regardless of the value of the Start-Stop bit.

In Watchdog mode, only the Prescaler Constant may be modified.

If the End of Count condition is reached a System Reset is generated.

TIMER/WATCHDOG (Cont'd)

10.1.3.3 Preventing Watchdog System Reset

In order to prevent a system reset, the sequence AAh, 55h must be written to WDTLR (Watchdog Timer Low Register). Once 55h has been written, the Timer reloads the constant and counting restarts from the preset value.

To reload the counter, the two writing operations must be performed sequentially without inserting other instructions that modify the value of the WDTLR register between the writing operations. The maximum allowed time between two reloads of the counter depends on the Watchdog timeout period.

10.1.3.4 Non-Stop Operation

In Watchdog Mode, a Halt instruction is regarded as illegal. Execution of the Halt instruction stops further execution by the CPU and interrupt acknowledgment, but does not stop INTCLK, CPU-CLK or the Watchdog Timer, which will cause a System Reset when the End of Count condition is reached. Furthermore, ST_SP, S_C and the Input Mode selection bits are ignored. Hence, regardless of their status, the counter always runs in Continuous Mode, driven by the internal clock.

The Output mode should not be enabled, since in this context it is meaningless.

Figure 88. Watchdog Timer Mode

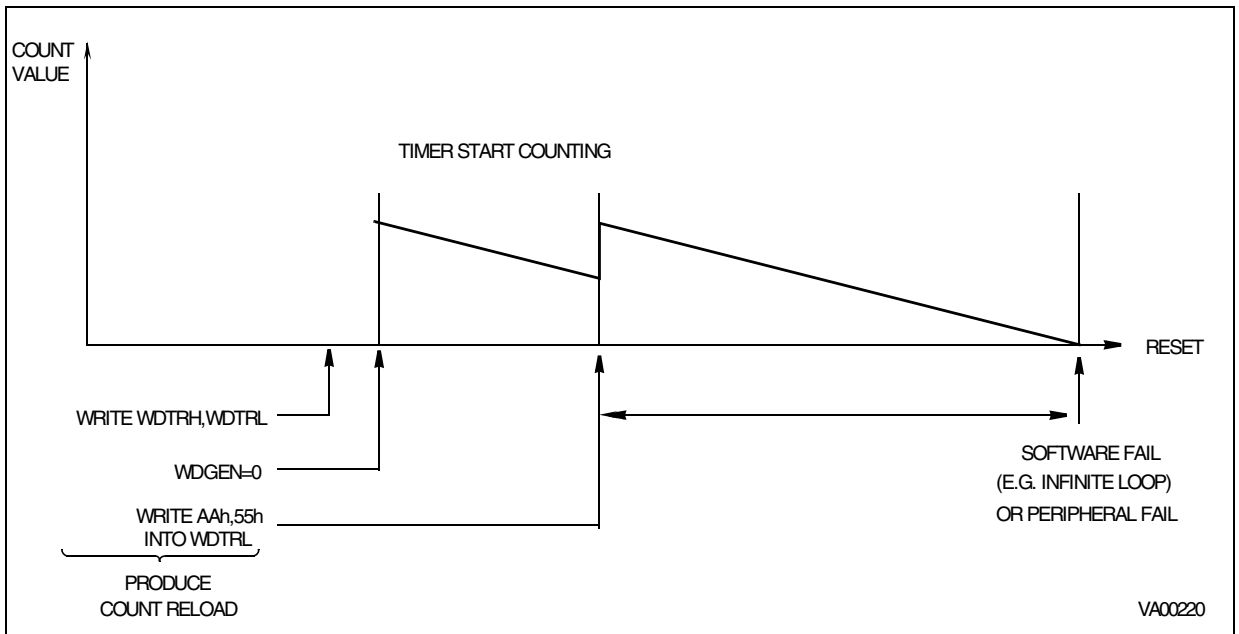

TIMER/WATCHDOG (Cont'd)

10.1.4 WDT Interrupts

The Timer/Watchdog issues an interrupt request at every End of Count, when this feature is enabled.

A pair of control bits, IA0S (EIVR.1, Interrupt A0 selection bit) and TLIS (EIVR.2, Top Level Input Selection bit) allow the selection of 2 interrupt sources (Timer/Watchdog End of Count, or External Pin) handled in two different ways, as a Top Level Non Maskable Interrupt (Software Reset), or as a source for channel A0 of the external interrupt logic.

A block diagram of the interrupt logic is given in Figure 89.

Note: Software traps can be generated by setting the appropriate interrupt pending bit.

Table 34 below, shows all the possible configurations of interrupt/reset sources which relate to the Timer/Watchdog.

A reset caused by the watchdog will set bit 6, WDGRES of R242 - Page 55 (Clock Flag Register). See section CLOCK CONTROL REGISTERS.

Figure 89. Interrupt Sources

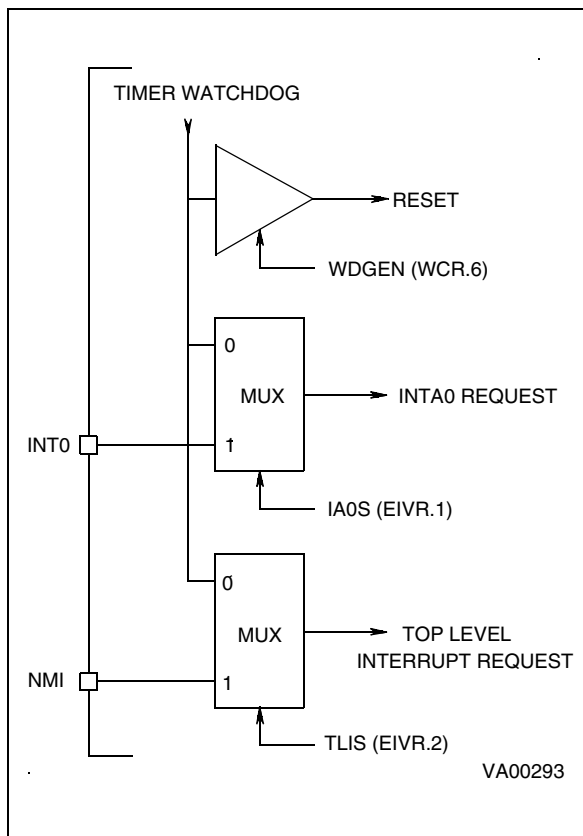

Table 34. Interrupt Configuration

Control Bits			Enabled Sources			Operating Mode
WDGEN	IA0S	TLIS	Reset	INTA0	Top Level	
0	0	0	WDG/Ext Reset	SW TRAP	SW TRAP	Watchdog
0	0	1	WDG/Ext Reset	SW TRAP	Ext Pin	Watchdog
0	1	0	WDG/Ext Reset	Ext Pin	SW TRAP	Watchdog
0	1	1	WDG/Ext Reset	Ext Pin	Ext Pin	Watchdog
1	0	0	Ext Reset	Timer	Timer	Timer
1	0	1	Ext Reset	Timer	Ext Pin	Timer
1	1	0	Ext Reset	Ext Pin	Timer	Timer
1	1	1	Ext Reset	Ext Pin	Ext Pin	Timer

Legend:

WDG = Watchdog function
 SW TRAP = Software Trap

Note: If IA0S and TLIS = 0 (enabling the Watchdog EOC as interrupt source for both Top Level and INTA0 interrupts), only the INTA0 interrupt is taken into account.

TIMER/WATCHDOG (Cont'd)

10.1.5 Register Description

The Timer/Watchdog is associated with 4 registers mapped into Group F, Page 0 of the Register File.

WDTHR: Timer/Watchdog High Register

WDTLR: Timer/Watchdog Low Register

WDTPR: Timer/Watchdog Prescaler Register

WDTCR: Timer/Watchdog Control Register

Three additional control bits are mapped in the following registers on Page 0:

Watchdog Mode Enable, (WCR.6)

Top Level Interrupt Selection, (EIVR.2)

Interrupt A0 Channel Selection, (EIVR.1)

Note: The registers containing these bits also contain other functions. Only the bits relevant to the operation of the Timer/Watchdog are shown here.

Counter Register

This 16-bit register (WDTLR, WDTHR) is used to load the 16-bit counter value. The registers can be read or written "on the fly".

TIMER/WATCHDOG HIGH REGISTER (WDTHR)

R248 - Read/Write

Register Page: 0

Reset value: 1111 1111 (FFh)

7							0
R15	R14	R13	R12	R11	R10	R9	R8

Bits 7:0 = **R[15:8]** Counter Most Significant Bits.

TIMER/WATCHDOG LOW REGISTER (WDTLR)

R249 - Read/Write

Register Page: 0

Reset value: 1111 1111b (FFh)

7							0
R7	R6	R5	R4	R3	R2	R1	R0

Bits 7:0 = **R[7:0]** Counter Least Significant Bits.

TIMER/WATCHDOG PRESCALER REGISTER (WDTPR)

R250 - Read/Write

Register Page: 0

Reset value: 1111 1111 (FFh)

7							0
PR7	PR6	PR5	PR4	PR3	PR2	PR1	PR0

Bits 7:0 = **PR[7:0]** Prescaler value.

A programmable value from 1 (00h) to 256 (FFh).

Warning: In order to prevent incorrect operation of the Timer/Watchdog, the prescaler (WDTPR) and counter (WDTRL, WDTRH) registers must be initialised before starting the Timer/Watchdog. If this is not done, counting will start with the reset (un-initialised) values.

WATCHDOG TIMER CONTROL REGISTER (WDTCR)

R251- Read/Write

Register Page: 0

Reset value: 0001 0010 (12h)

7							0
ST_SP	S_C	INMD1	INMD2	INEN	OUTMD	WR0UT	OUTEN

Bit 7 = **ST_SP:** Start/Stop Bit.

This bit is set and cleared by software.

0: Stop counting

1: Start counting (see Warning above)

Bit 6 = **S_C:** Single/Continuous.

This bit is set and cleared by software.

0: Continuous Mode

1: Single Mode

Bits 5:4 = **INMD[1:2]:** Input mode selection bits.

These bits select the input mode:

INMD1	INMD2	INPUT MODE
0	0	Event Counter
0	1	Gated Input (Reset value)
1	0	Triggerable Input
1	1	Retriggerable Input

TIMER/WATCHDOG (Cont'd)

Bit 3 = **INEN**: *Input Enable*.

This bit is set and cleared by software.

0: Disable input section

1: Enable input section

Bit 2 = **OUTMD**: *Output Mode*.

This bit is set and cleared by software.

0: The output is toggled at every End of Count

1: The value of the WROUT bit is transferred to the output pin on every End Of Count if OUTEN=1.

Bit 1 = **WROUT**: *Write Out*.

The status of this bit is transferred to the Output pin when OUTMD is set; it is user definable to allow PWM output (on Reset WROUT is set).

Bit 0 = **OUTEN**: *Output Enable bit*.

This bit is set and cleared by software.

0: Disable output

1: Enable output

WAIT CONTROL REGISTER (WCR)

R252 - Read/Write

Register Page: 0

Reset value: 0111 1111 (7Fh)

7							0
x	WDGEN	x	x	x	x	x	x

Bit 6 = **WDGEN**: *Watchdog Enable* (active low).

Resetting this bit via software enters the Watchdog mode. Once reset, it cannot be set any more

by the user program. At System Reset, the Watchdog mode is disabled.

Note: This bit is ignored if the Hardware Watchdog option is enabled by pin HW0SW1 (if available).

EXTERNAL INTERRUPT VECTOR REGISTER (EIVR)

R246 - Read/Write

Register Page: 0

Reset value: xxxx 0110 (x6h)

7							0
x	x	x	x	x	TLIS	IAOS	x

Bit 2 = **TLIS**: *Top Level Input Selection*.

This bit is set and cleared by software.

0: Watchdog End of Count is TL interrupt source

1: NMI is TL interrupt source

Bit 1 = **IAOS**: *Interrupt Channel A0 Selection*.

This bit is set and cleared by software.

0: Watchdog End of Count is INTA0 source

1: External Interrupt pin is INTA0 source

Warning: To avoid spurious interrupt requests, the IAOS bit should be accessed only when the interrupt logic is disabled (i.e. after the DI instruction). It is also necessary to clear any possible interrupt pending requests on channel A0 before enabling this interrupt channel. A delay instruction (e.g. a NOP instruction) must be inserted between the reset of the interrupt pending bit and the IAOS write instruction.

Other bits are described in the Interrupt section.

10.2 STANDARD TIMER (STIM)

10.2.1 Introduction

The Standard Timer includes a programmable 16-bit down counter and an associated 8-bit prescaler with Single and Continuous counting modes capability. The Standard Timer uses an output (STOUT) pin. This pin may be independent pin or connected as Alternate Function of an I/O port bit.

STOUT can be used to generate a Square Wave or Pulse Width Modulated signal.

The Standard Timer is composed of a 16-bit down counter with an 8-bit prescaler. The input clock to

the prescaler can be driven either by an internal clock equal to INTCLK divided by 4, or by CLOCK2/1024 derived directly from the external oscillator, thus providing a stable time reference independent from the PLL programming (refer to [Figure 90](#)).

The Standard Timer End Of Count condition is able to generate an interrupt which is connected to one of the external interrupt channels.

The End of Count condition is defined as the Counter Underflow, whenever 00h is reached.

Figure 90. Standard Timer Block Diagram

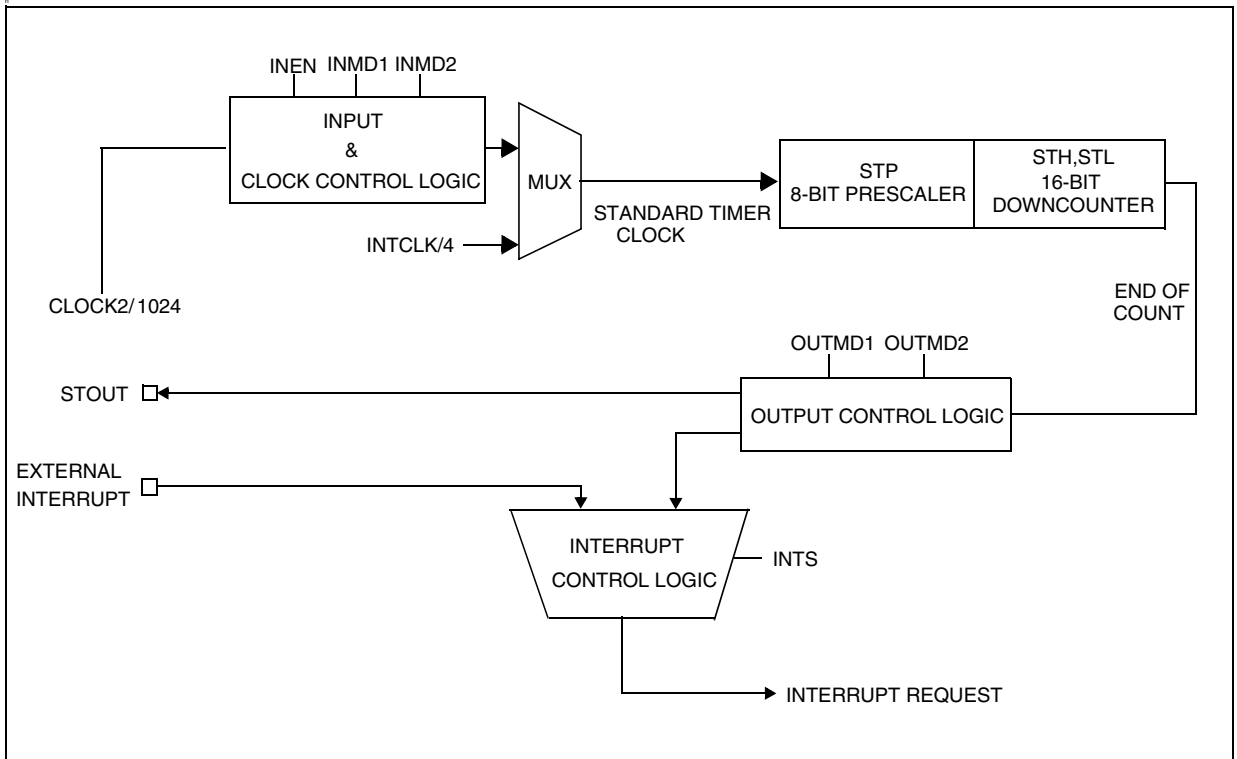

STANDARD TIMER (Cont'd)

10.2.2 Functional Description

10.2.2.1 Timer/Counter control

Start-stop Count. The ST-SP bit (STC.7) is used in order to start and stop counting. An instruction which sets this bit will cause the Standard Timer to start counting at the beginning of the next instruction. Resetting this bit will stop the counter.

If the counter is stopped and restarted, counting will resume from the value held at the stop condition, unless a new constant has been entered in the Standard Timer registers during the stop period. In this case, the new constant will be loaded as soon as counting is restarted.

A new constant can be written in STH, STL, STP registers while the counter is running. The new value of the STH and STL registers will be loaded at the next End of Count condition, while the new value of the STP register will be loaded immediately.

WARNING: In order to prevent incorrect counting of the Standard Timer, the prescaler (STP) and counter (STL, STH) registers must be initialised before the starting of the timer. If this is not done, counting will start with the reset values (STH=FFh, STL=FFh, STP=FFh).

Single/Continuous Mode.

The S-C bit (STC.6) selects between the Single or Continuous mode.

SINGLE MODE: at the End of Count, the Standard Timer stops, reloads the constant and resets the Start/Stop bit (the user programmer can inspect the timer current status by reading this bit). Setting the Start/Stop bit will restart the counter.

CONTINUOUS MODE: At the End of the Count, the counter automatically reloads the constant and restarts. It is only stopped by resetting the Start/Stop bit.

The S-C bit can be written either with the timer stopped or running. It is possible to toggle the S-C bit and start the Standard Timer with the same instruction.

10.2.2.2 Time Base Generator

The INEN bit in the STC register selects the clock source (refer to RCCU section).

When the INEN bit is reset, INTCLK/4 is selected as clock input.

When the INEN bit is set, CLOCK2/1024 is selected as clock input. In this case, INMD1 and INMD2 bits in the STC register must always be kept at 0 to select the event counter mode. This mode allows the Standard Timer to generate a stable time base independent from PLL programming.

10.2.2.3 Standard Timer Output Modes

OUTPUT modes are selected using 2 bits of the STC register: OUTMD1 and OUTMD2.

No Output Mode (OUTMD1 = "0", OUTMD2 = "0")

The output is disabled and the corresponding pin is set high, in order to allow other alternate functions to use the I/O pin.

Square Wave Output Mode (OUTMD1 = "0", OUTMD2 = "1")

The Standard Timer toggles the state of the STOUT pin on every End Of Count condition. With INTCLK = 24MHz, this allows generation of a square wave with a period ranging from 333ns (STP = STH = STL = 00h) to 5.59 seconds (STP = STH = STL = FFh).

PWM Output Mode (OUTMD1 = "1")

The value of the OUTMD2 bit is transferred to the STOUT output pin at the End Of Count. This allows the user to generate PWM signals, by modifying the status of OUTMD2 between End of Count events, based on software counters decremented on the Standard Timer interrupt.

10.2.3 Interrupt Selection

The Standard Timer may generate an interrupt request at every End of Count.

Bit 2 of the STC register (INTS) selects the interrupt source between the Standard Timer interrupt and the external interrupt pin. Thus the Standard Timer Interrupt uses the interrupt channel and takes the priority and vector of the external interrupt channel.

If INTS is set to "1", the Standard Timer interrupt is disabled; otherwise, an interrupt request is generated at every End of Count.

Note: When enabling or disabling the Standard Timer Interrupt (writing INTS in the STC register) an edge may be generated on the interrupt channel, causing an unwanted interrupt.

To avoid this spurious interrupt request, the INTS bit should be accessed only when the interrupt logic is disabled (i.e. after the DI instruction). It is also necessary to clear any possible interrupt pending requests on the corresponding external interrupt channel before enabling it. A delay instruction (i.e. a NOP instruction) must be inserted between the reset of the interrupt pending bit and the INTS write instruction.

STANDARD TIMER (Cont'd)

10.2.4 Register Description

COUNTER HIGH BYTE REGISTER (STH)

R240 - Read/Write

Register Page: 11

Reset value: 1111 1111 (FFh)

7								0
ST.15	ST.14	ST.13	ST.12	ST.11	ST.10	ST.9	ST.8	

Bits 7:0 = **ST.[15:8]**: *Counter High-Byte.*

COUNTER LOW BYTE REGISTER (STL)

R241 - Read/Write

Register Page: 11

Reset value: 1111 1111 (FFh)

7								0
ST.7	ST.6	ST.5	ST.4	ST.3	ST.2	ST.1	ST.0	

Bits 7:0 = **ST.[7:0]**: *Counter Low Byte.*

Writing to the STH and STL registers allows the user to enter the standard timer constant from 1 (0000h) to 65536 (FFFFh). Reading these registers provides the counter's current value. Thus it is possible to read the counter on-the-fly.

STANDARD TIMER PRESCALER REGISTER (STP)

R242 - Read/Write

Register Page: 11

Reset value: 1111 1111 (FFh)

7								0
STP.7	STP.6	STP.5	STP.4	STP.3	STP.2	STP.1	STP.0	

Bits 7:0 = **STP.[7:0]**: *Prescaler.*

The Prescaler value for the Standard Timer is programmed into this register. When reading the STP register, the returned value corresponds to the programmed data instead of the current data.

00h: No prescaler

01h: Divide by 2

FFh: Divide by 256

STANDARD TIMER CONTROL REGISTER (STC)

R243 - Read/Write

Register Page: 11

Reset value: 0001 0100 (14h)

7							0
ST-SP	S-C	INMD1	INMD2	INEN	INTS	OUTMD1	OUTMD2

Bit 7 = **ST-SP**: *Start-Stop Bit.*

This bit is set and cleared by software.

0: Stop counting

1: Start counting

Bit 6 = **S-C**: *Single-Continuous Mode Select.*

This bit is set and cleared by software.

0: Continuous Mode

1: Single Mode

Bits 5:4 = **INMD[1:2]**

Bit 3 = **INEN**

These 3 bits select the clock source.

INMD1	INMD2	INEN	Clock input
0	0	1	CLOCK2/1024
X	X	0	INTCLK/4

Bit 2 = **INTS**: *Interrupt Selection.*

0: Standard Timer interrupt enabled

1: Standard Timer interrupt is disabled and the external interrupt pin is enabled.

Bits 1:0 = **OUTMD[1:2]**: *Output Mode Selection.*

These bits select the output functions as described in [Section 10.2.2.3](#).

OUTMD1	OUTMD2	Mode
0	0	No output mode
0	1	Square wave output mode
1	x	PWM output mode

10.3 EXTENDED FUNCTION TIMER (EFT)

10.3.1 Introduction

The timer consists of a 16-bit free-running counter driven by a programmable prescaler.

It may be used for a variety of purposes, including pulse length measurement of up to two input signals (*input capture*) or generation of up to two output waveforms (*output compare* and *PWM*).

Pulse lengths and waveform periods can be modulated from a few microseconds to several milliseconds using the timer prescaler and the INTCLK prescaler.

10.3.2 Main Features

- Programmable prescaler: INTCLK divided by 2, 4 or 8.
- Overflow status flag and maskable interrupts
- External clock input (must be at least 4 times slower than the INTCLK clock speed) with the choice of active edge
- Output compare functions with
 - 2 dedicated 16-bit registers
 - 2 dedicated programmable signals
 - 2 dedicated status flags
 - Maskable interrupt generation
- Input capture functions with
 - 2 dedicated 16-bit registers
 - 2 dedicated active edge selection signals
 - 2 dedicated status flags
 - Maskable interrupt generation
- Pulse width modulation mode (PWM)
- One pulse mode
- 5 alternate functions on I/O ports
- Global Timer interrupt (EFTI).

The Block Diagram is shown in [Figure 91](#).

Table 35. EFT Pin Naming conventions

Function	EFT0	EFT1
Input Capture 1 - ICAP1	ICAPA0	ICAPA1
Input Capture 2 - ICAP2	ICAPB0	ICAPB1
Output Compare 1 - OCMP1	OCMPA0	OCMPA1
Output Compare 2 - OCMP2	OCMPB0	OCMPB1

10.3.3 Functional Description

10.3.3.1 Counter

The principal block of the Programmable Timer is a 16-bit free running counter and its associated 16-bit registers:

Counter Registers

- Counter High Register (CHR) is the most significant byte (MSB).
- Counter Low Register (CLR) is the least significant byte (LSB).

Alternate Counter Registers

- Alternate Counter High Register (ACHR) is the most significant byte (MSB).
- Alternate Counter Low Register (ACLR) is the least significant byte (LSB).

These two read-only 16-bit registers contain the same value but with the difference that reading the ACLR register does not clear the TOF bit (overflow flag), (see note [page 169](#)).

Writing in the CLR register or ACLR register resets the free running counter to the FFFCh value.

The timer clock depends on the clock control bits of the CR2 register, as illustrated in [Table 36](#). The value in the counter register repeats every 131.072, 262.144 or 524.288 INTCLK cycles depending on the CC[1:0] bits.

EXTENDED FUNCTION TIMER (EFT)

EXTENDED FUNCTION TIMER (Cont'd)

Figure 91. Timer Block Diagram

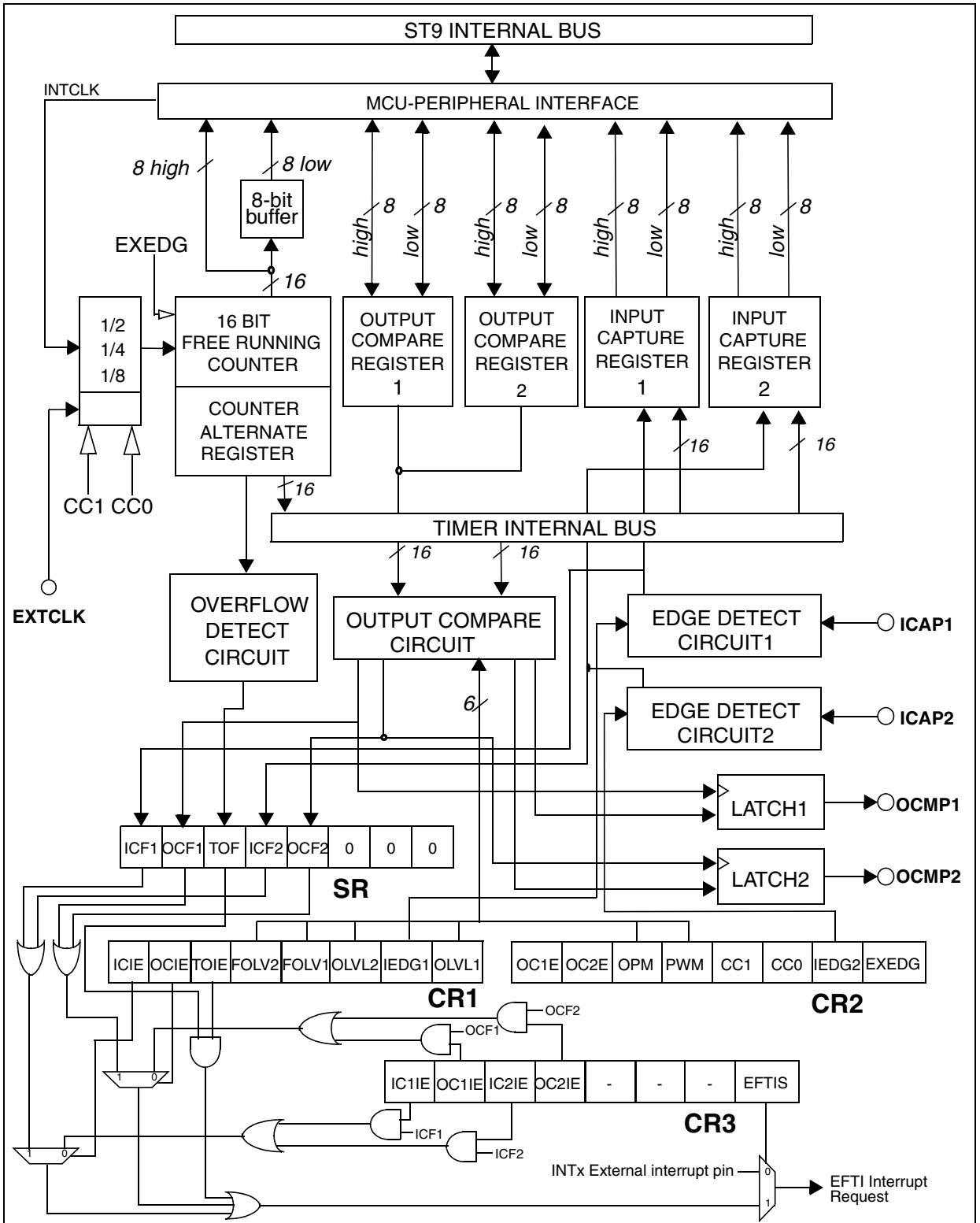

EXTENDED FUNCTION TIMER (Cont'd)

16-bit read sequence: (from either the Counter Register or the Alternate Counter Register).

Beginning of the sequence

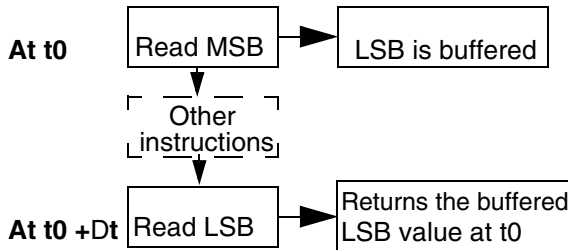

Sequence completed

The user must read the MSB first, then the LSB value is buffered automatically.

This buffered value remains unchanged until the 16-bit read sequence is completed, even if the user reads the MSB several times.

After a complete reading sequence, if only the CLR register or ACLR register are read, they return the LSB of the count value at the time of the read.

An overflow occurs when the counter rolls over from FFFFh to 0000h then:

- The TOF bit of the SR register is set.
- A timer interrupt is generated if:
 - TOIE bit of the CR1 register is set
 - EFTIS bit of the CR3 register is set.

If one of these conditions is false, the interrupt remains pending to be issued as soon as they are both true.

Clearing the overflow interrupt request is done by:

1. Reading the SR register while the TOF bit is set.
2. An access (read or write) to the CLR register.

Notes: The TOF bit is not cleared by accesses to ACLR register. This feature allows simultaneous use of the overflow function and reads of the free running counter at random times (for example, to measure elapsed time) without the risk of clearing the TOF bit erroneously.

The timer is not affected by WAIT mode.

In HALT mode, the counter stops counting until the mode is exited. Counting then resumes from the reset count (MCU awakened by a Reset).

10.3.3.2 External Clock

The external clock (where available) is selected if CC0=1 and CC1=1 in CR2 register.

The status of the EXEDG bit determines the type of level transition on the external clock pin EXT-CLK that will trigger the free running counter.

The counter is synchronised with the falling edge of INTCLK.

At least four falling edges of the INTCLK must occur between two consecutive active edges of the external clock; thus the external clock frequency must be less than a quarter of the INTCLK frequency.

EXTENDED FUNCTION TIMER (EFT)

EXTENDED FUNCTION TIMER (Cont'd)

Figure 92. Counter Timing Diagram, INTCLK divided by 2

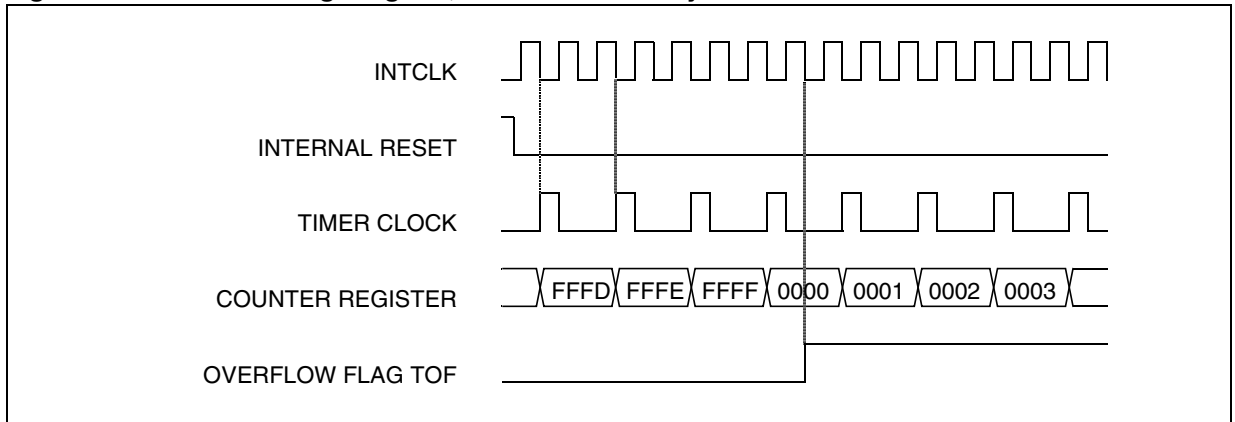

Figure 93. Counter Timing Diagram, INTCLK divided by 4

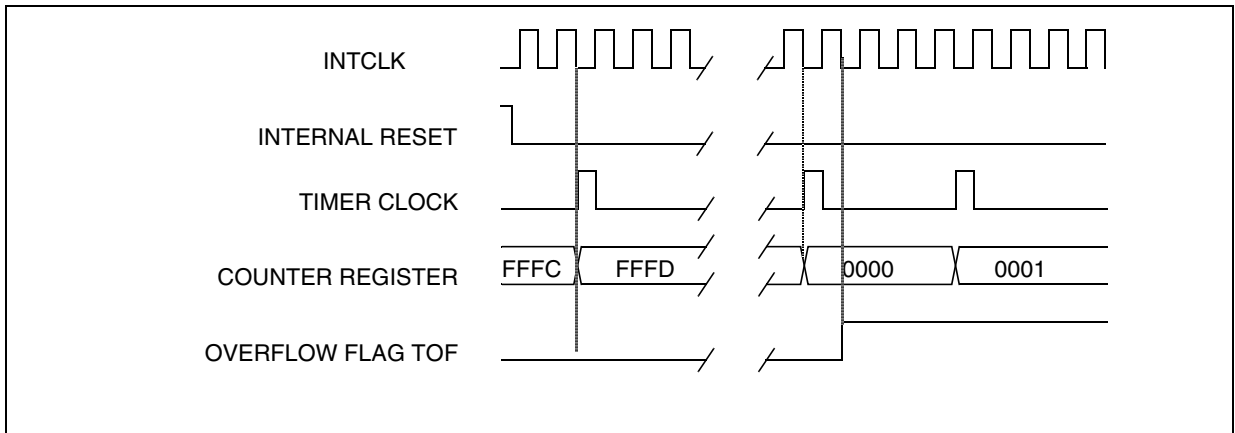
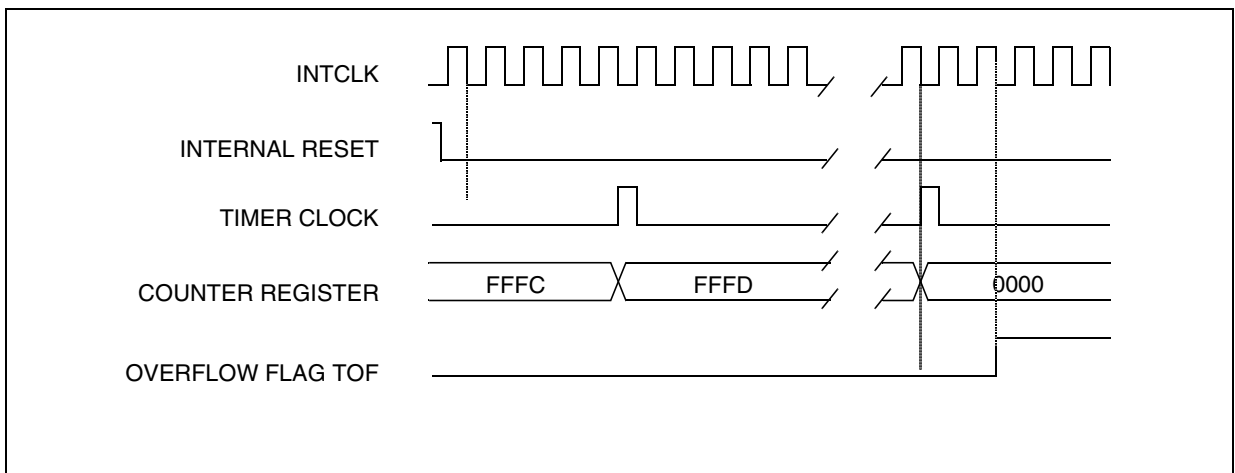

Figure 94. Counter Timing Diagram, INTCLK divided by 8



EXTENDED FUNCTION TIMER (Cont'd)

10.3.3.3 Input Capture

In this section, the index, *i*, may be 1 or 2.

The two input capture 16-bit registers (IC1R and IC2R) are used to latch the value of the free running counter after a transition detected by the ICAP*i* pin (see figure 5).

	MS Byte	LS Byte
IC<i>i</i>R	IC<i>i</i>HR	IC<i>i</i>LR

IC*i*R register is a read-only register.

The active transition is software programmable through the IEDG*i* bit of the Control Register (CR).

Timing resolution is one count of the free running counter: (INTCLK/CC[1:0]).

Procedure

To use the input capture function select the following in the CR2 register:

- Select the timer clock (CC[1:0]) (see Table 36).
- Select the edge of the active transition on the ICAP2 pin with the IEDG2 bit, if ICAP2 is active.

And select the following in the CR1/CR3 register:

- To enable both ICAP1 & ICAP2 interrupts, set the ICIE bit in the CR1 register (in this case, the IC1IE & IC2IE enable bits are not significant). To enable only one ICAP interrupt, reset the ICIE bit and set the IC1IE (or IC2IE) bit.

Note: If ICIE is reset and both IC1IE & IC2IE are set, both interrupts are enabled.

In all cases, set the EFTIS bit to enable timer interrupts globally

- Select the edge of the active transition on the ICAP1 pin with the IEDG1 bit if ICAP1 is active.

When an input capture occurs:

- ICF*i* bit is set.
- The IC*i*R register contains the value of the free running counter on the active transition on the ICAP*i* pin (see Figure 96).

- A timer interrupt is generated under the following two conditions :

1. If the ICIE bit (for both ICAP1 & ICAP2) and the EFTIS bit are set.
Note: If the ICIE bit is set, the status of the IC1IE/IC2IE bits in the CR3 register is not significant.
2. If the ICIE bit is reset and the IC1IE and /or IC2IE bits are set and the EFTIS bit is set.

Otherwise, the interrupt remains pending until the related enable bits are set.

Clearing the Input Capture interrupt request is done by:

1. An access (read or write) to the SR register while the ICF*i* bit is set.
2. An access (read or write) to the IC*i*LR register.

Note: After reading the IC*i*HR register, transfer of input capture data is inhibited until the IC*i*LR register is also read.

The IC*i*R register always contains the free running counter value which corresponds to the most recent input capture.

EXTENDED FUNCTION TIMER (EFT)

EXTENDED FUNCTION TIMER (Cont'd)

Figure 95. Input Capture Block Diagram

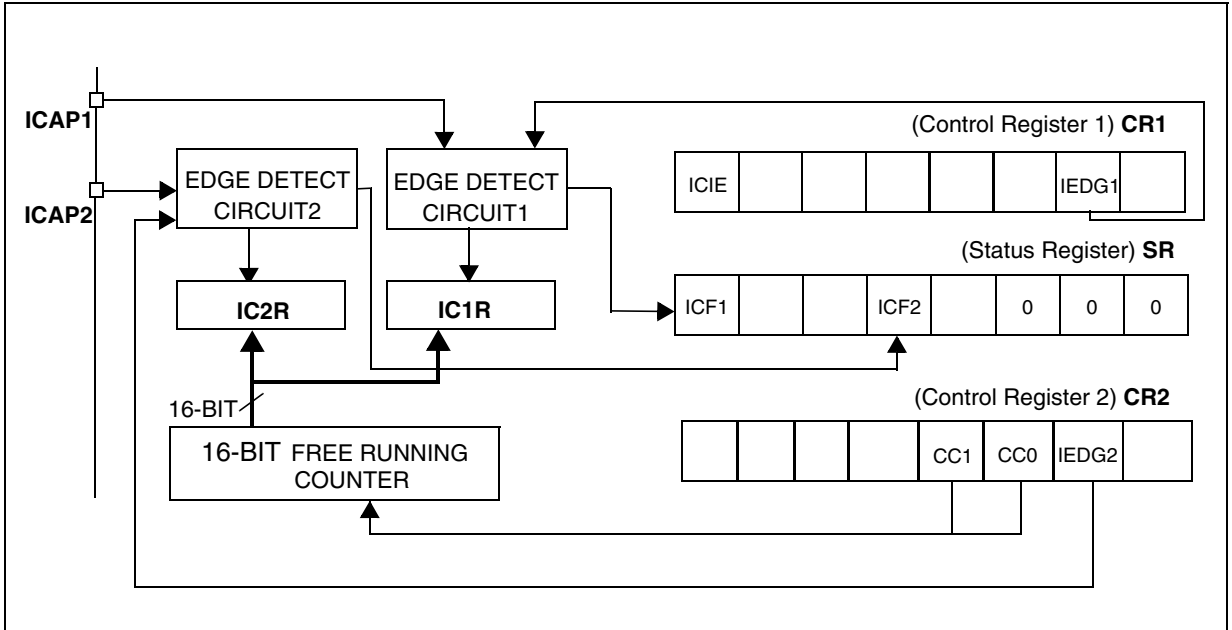
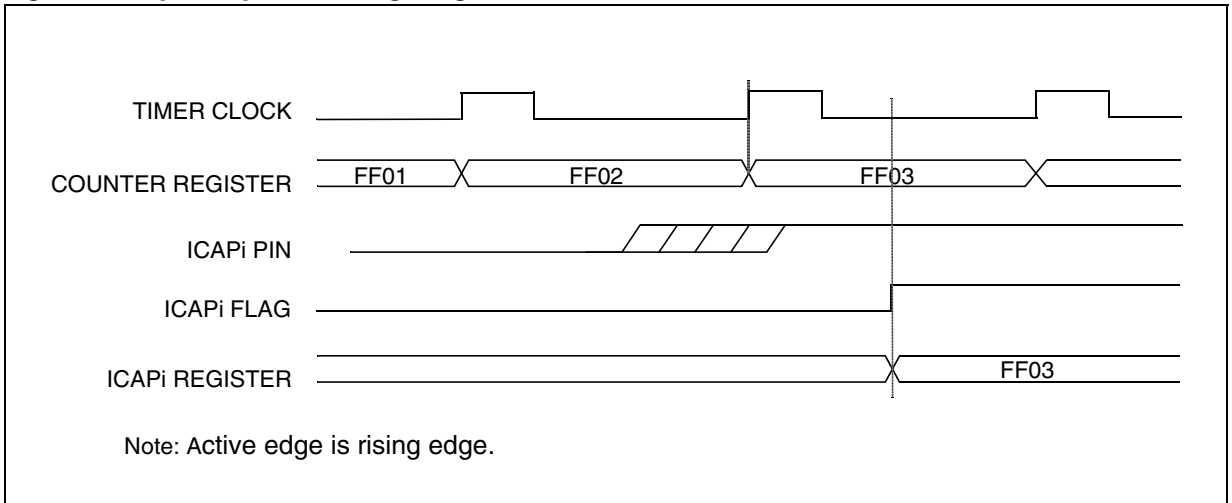

Figure 96. Input Capture Timing Diagram



EXTENDED FUNCTION TIMER (Cont'd)

10.3.3.4 Output Compare

In this section, the index, *i*, may be 1 or 2.

This function can be used to control an output waveform or indicating when a period of time has elapsed.

When a match is found between the Output Compare register and the free running counter, the output compare function:

- Assigns pins with a programmable value if the OC $\bar{I}E$ bit is set
- Sets a flag in the status register
- Generates an interrupt if enabled

Two 16-bit registers Output Compare Register 1 (OC1R) and Output Compare Register 2 (OC2R) contain the value to be compared to the free running counter each timer clock cycle.

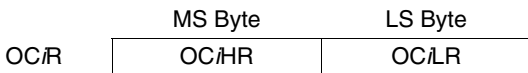

These registers are readable and writable and are not affected by the timer hardware. A reset event changes the OC $\bar{I}R$ value to 8000h.

Timing resolution is one count of the free running counter: (INTCLK/CC[1:0]).

Procedure

To use the output compare function, select the following in the CR2 register:

- Set the OC $\bar{I}E$ bit if an output is needed, the OCMP \bar{i} pin is then dedicated to the output compare function.
- Select the timer clock (CC[1:0] see Table 36).

Select the following in the CR1/CR3 register:

- Select the OLVL \bar{i} bit to be applied to the OCMP pins after the match occurs.
- To enable both OCMP1 & OCMP2 interrupts, set the OCIE bit in the CR1 register (in this case, the OC1IE & OC2IE enable bits are not significant). To enable only one OCMP interrupt, reset the OCIE bit and set the OC1IE (or OC2IE) bit.

Note: If OCIE is reset and both OC1IE & OC2IE are set, both interrupts are enabled.

In all cases, set the EFTIS bit to enable timer interrupts globally.

When a match is found:

- The OCF \bar{i} bit is set.
- The OCMP \bar{i} pin takes the OLVL \bar{i} bit value (the OCMP \bar{i} pin latch is forced low during reset and stays low until a valid compare changes it to the OLVL \bar{i} level).

- A timer interrupt is generated under the following two conditions :

1. If the OCIE bit (for both OCMP1 & OCMP2) and the EFTIS bit are set.
Note: If the OCIE bit is set, the status of the OC1IE/OC2IE bits in the CR3 register is not significant.
2. If the OCIE bit is reset and the OC1IE and /or OC2IE bits are set and the EFTIS bit is set.

Otherwise, the interrupt remains pending until the related enable bits are set.

Clearing the output compare interrupt request is done by:

- An access (read or write) to the SR register while the OCF \bar{i} bit is set.
- An access (read or write) to the OC $\bar{I}LR$ register.

Note: After a write access to the OC $\bar{I}HR$ register, the output compare function is inhibited until the OC $\bar{I}LR$ register is also written.

If the OC $\bar{I}E$ bit is not set, the OCMP \bar{i} pin is a general I/O port and the OLVL \bar{i} bit will not appear when match is found but an interrupt could be generated if the OCIE bit is set.

The value in the 16-bit OC $\bar{I}R$ register and the OLVL \bar{i} bit should be changed after each successful comparison in order to control an output waveform or establish a new elapsed timeout.

The OC $\bar{I}R$ register value required for a specific timing application can be calculated using the following formula:

$$\Delta OC\bar{I}R = \frac{\Delta t * INTCLK}{(CC1.CC0)}$$

Where:

- Δt = Desired output compare period (in seconds)
- INTCLK = Internal clock frequency
- CC[1:0] = Timer clock prescaler

The following procedure is recommended to prevent the OCF \bar{i} bit from being set between the time it is read and the write to the OC $\bar{I}R$ register:

- Write to the OC $\bar{I}HR$ register (further compares are inhibited).
- Read the SR register (first step of the clearance of the OCF \bar{i} bit, which may be already set).
- Write to the OC $\bar{I}LR$ register (enables the output compare function and clears the OCF \bar{i} bit).

EXTENDED FUNCTION TIMER (EFT)

EXTENDED FUNCTION TIMER (Cont'd)

Figure 97. Output Compare Block Diagram

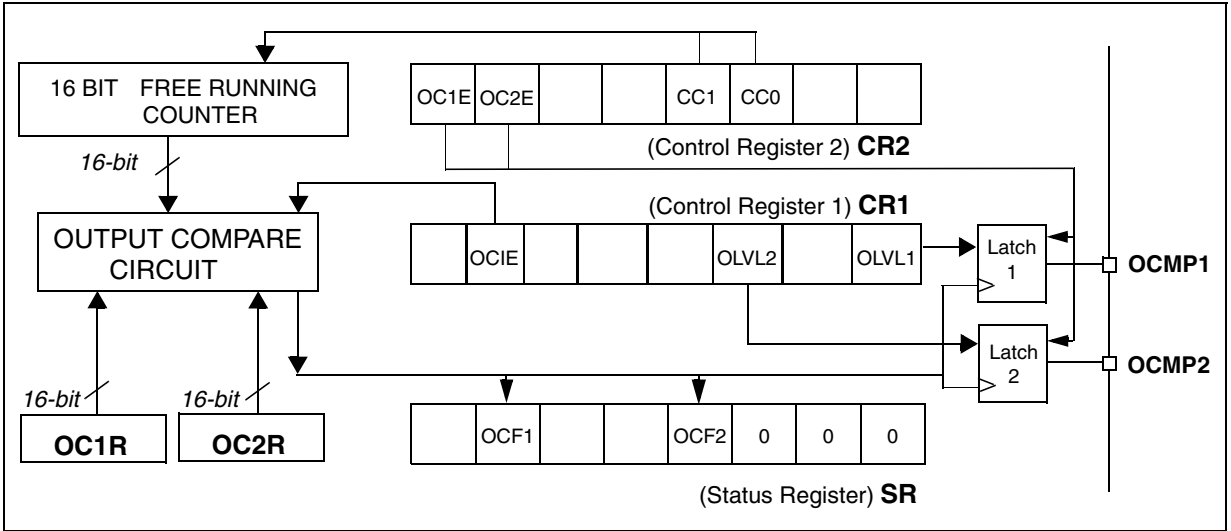
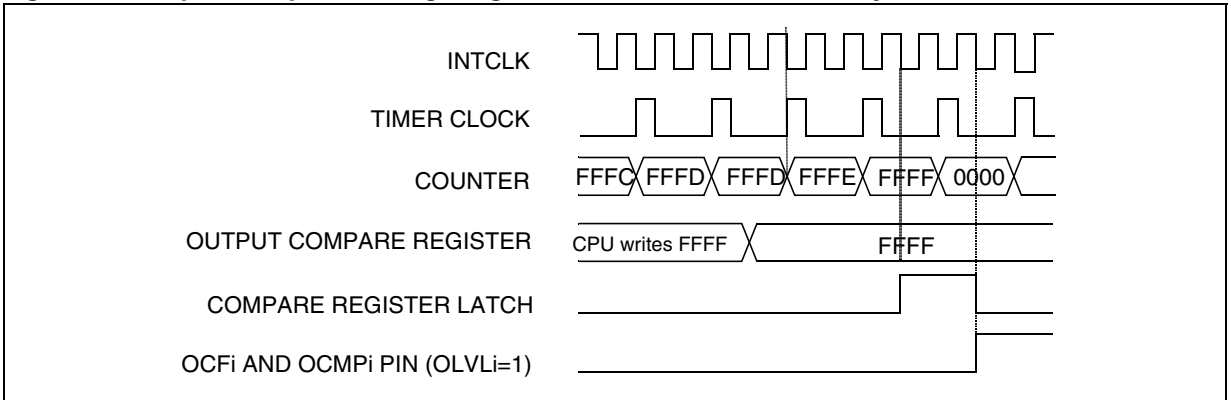

Figure 98. Output Compare Timing Diagram, Internal Clock Divided by 2



EXTENDED FUNCTION TIMER (Cont'd)

10.3.3.5 Forced Compare Mode

In this section i may represent 1 or 2.

The following bits of the CR1 register are used:

			FOLV2	FOLV1	OLVL2		OLVL1
--	--	--	-------	-------	-------	--	-------

When the FOLV1 bit is set, the OLVL1 bit is copied to the OCMP1 pin if PWM and OPM are both cleared.

When the FOLV2 bit is set, the OLVL2 bit is copied to the OCMP2 pin.

The OLVL i bit has to be toggled in order to toggle the OCMP i pin when it is enabled (OC \bar{E} bit=1).

Notes:

- The OCF i bit is not set when FOLV i is set, and thus no interrupt request is generated.
- The OCF i bit can be set if OC \bar{R} = Counter and an interrupt can be generated if enabled. This can be avoided by writing in the OC \bar{H} R register. The output compare function is inhibited till OC \bar{L} R is also written.
- The Input Capture function works in Forced compare mode. To disable it, read the IC \bar{H} R register. Input capture will be inhibited till IC \bar{L} R is read.

10.3.3.6 One Pulse Mode

One Pulse mode enables the generation of a pulse when an external event occurs. This mode is selected via the OPM bit in the CR2 register.

The one pulse mode uses the Input Capture1 function and the Output Compare1 function.

Procedure

To use one pulse mode, select the following in the the CR1 register:

- Using the OLVL1 bit, select the level to be applied to the OCMP1 pin after the pulse.
- Using the OLVL2 bit, select the level to be applied to the OCMP1 pin during the pulse.
- Select the edge of the active transition on the ICAP1 pin with the IEDG1 bit.

And select the following in the CR2 register:

- Set the OC1E bit, the OCMP1 pin is then dedicated to the Output Compare 1 function.
- Set the OPM bit.
- Select the timer clock CC[1:0] (see [Table 36](#)).

Load the OC1R register with the value corresponding to the length of the pulse (see the formula in [Section 10.3.3.7](#)).

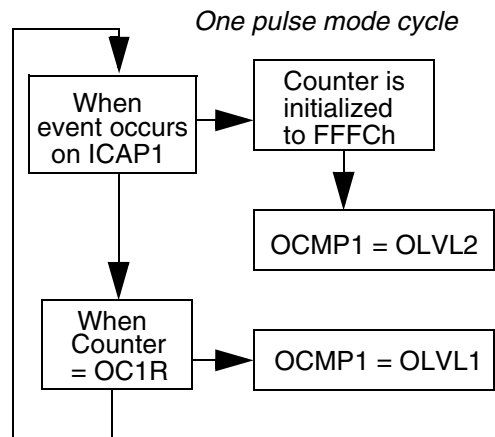

Then, on a valid event on the ICAP1 pin, the counter is initialized to FFFCh and OLVL2 bit is loaded on the OCMP1 pin. When the value of the counter is equal to the value of the contents of the OC1R register, the OLVL1 bit is output on the OCMP1 pin, (See [Figure 99](#)).

Notes:

- The OCF1 bit cannot be set by hardware in one pulse mode but the OCF2 bit can generate an Output Compare interrupt.
- The ICF1 bit is set when an active edge occurs and can generate an interrupt if the ICIE bit is set or ICIE is reset and IC1IE is set. The IC1R register will have the value FFFCh.
- When the Pulse Width Modulation (PWM) and One Pulse Mode (OPM) bits are both set, the PWM mode is the only active one.
- When One Pulse Mode (OPM) and Forced Compare 1 mode (FOLV1) bits are set then OPM is the active mode
- Forced Compare 2 mode works in OPM
- Input Capture 2 function works in OPM
- When OC1R = FFFCh in OPM, then a pulse of width FFFCh is generated
- If IC1HR register is read in OPM before an active edge of ICAP1, then OPM is inhibited till IC1LR is also read.

EXTENDED FUNCTION TIMER (Cont'd)

– If an event occurs on ICAP1 again before the Counter reaches the OC1R value, then the Counter will be reset again and the pulse generated might be longer than expected as in [Figure 99](#).

– If a write operation is performed on CLR or ACLR register before the Counter reaches the OC1R value, then the Counter will be reset again and the pulse generated might be longer than expected.

Figure 99. One Pulse Mode Timing

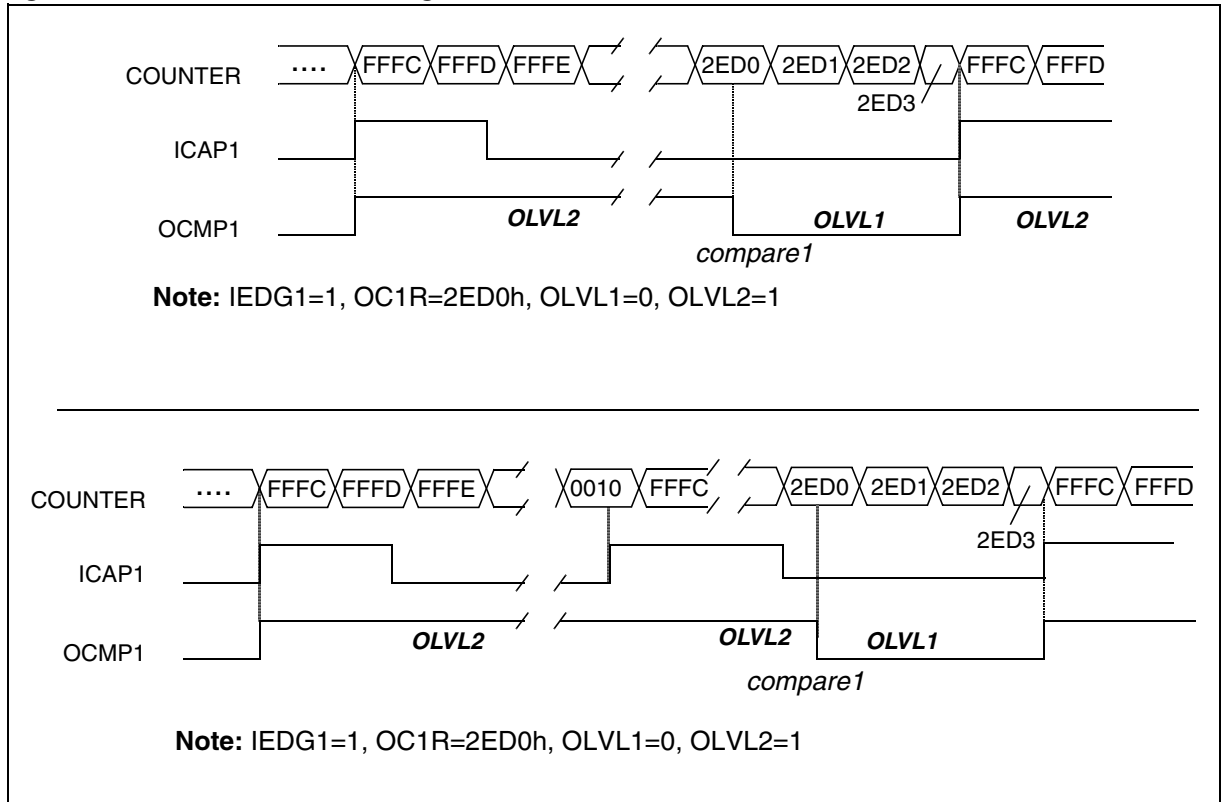

EXTENDED FUNCTION TIMER (Cont'd)

10.3.3.7 Pulse Width Modulation Mode

Pulse Width Modulation mode enables the generation of a signal with a frequency and pulse length determined by the value of the OC1R and OC2R registers.

The pulse width modulation mode uses the complete Output Compare 1 function plus the OC2R register.

Procedure

To use pulse width modulation mode select the following in the CR1 register:

- Using the OLVL1 bit, select the level to be applied to the OCMP1 pin after a successful comparison with OC1R register.
- Using the OLVL2 bit, select the level to be applied to the OCMP1 pin after a successful comparison with OC2R register.

And select the following in the CR2 register:

- Set OC1E bit: the OCMP1 pin is then dedicated to the output compare 1 function.
- Set the PWM bit.
- Select the timer clock CC[1:0] bits (see [Table 36](#)).

Load the OC2R register with the value corresponding to the period of the signal.

Load the OC1R register with the value corresponding to the length of the pulse if (OLVL1=0 and OLVL2=1).

If OLVL1=1 and OLVL2=0 the length of the pulse is the difference between the OC2R and OC1R registers.

The OC*R* register value required for a specific timing application can be calculated using the following formula:

$$\text{OC/R Value} = \frac{t * \text{INTCLK}}{\text{CC}[1:0]} - 5$$

Where:

- t = Desired output compare period (seconds)
- INTCLK = Internal clock frequency
- CC1-CC0 = Timer clock prescaler

The Output Compare 2 event causes the counter to be initialized to FFFCh (See [Figure 100](#)).

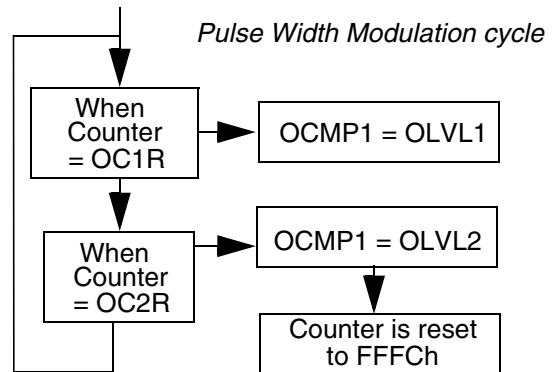
Notes:

- After a write instruction to the OC*R*R register, the output compare function is inhibited until the OC*L*R register is also written.
- The OCF1 bit cannot be set by hardware in PWM mode, but the OCF2 bit is set every time the counter matches the OC2R register.
- The Input Capture function is available in PWM mode.
- When Counter = OC2R, then the OCF2 bit will be set. This can generate an interrupt if OCIE is set or OCIE is reset and OC2IE is set. This interrupt is useful in applications where the pulse-width or period needs to be changed interactively.
- When the Pulse Width Modulation (PWM) and One Pulse Mode (OPM) bits are both set, the PWM mode is the only active mode.
- The value loaded in register OC2R **must always be greater than** the value in register OC1R in order to produce meaningful waveforms. Note that 0000h is considered to be greater than FFFCh or FFFDh or FFFEh or FFFFh.
- When OC1R > OC2R, no waveform will be generated.
- When OC2R = OC1R, a **square** waveform will be generated as in [Figure 100](#)
- When OC2R is loaded with FFFC (the counter reset value) then no waveform will be generated & the counter will remain stuck at FFFC.
- When OC1R is loaded with FFFC (the counter reset value) then the waveform will be generated as in [Figure 100](#)
- When FOLV1 bit is set and PWM bit is set, then PWM mode is the active one. But if FOLV2 bit is set then the OLVL2 bit will appear on OCMP2 (when OC2E bit = 1).

EXTENDED FUNCTION TIMER (EFT)

EXTENDED FUNCTION TIMER (Cont'd)

- When a write is performed on the CLR or ACLR register in PWM mode, then the Counter will be reset and the pulse-width/period of the waveform generated may not be as desired

Figure 100. Pulse Width Modulation Mode Timing

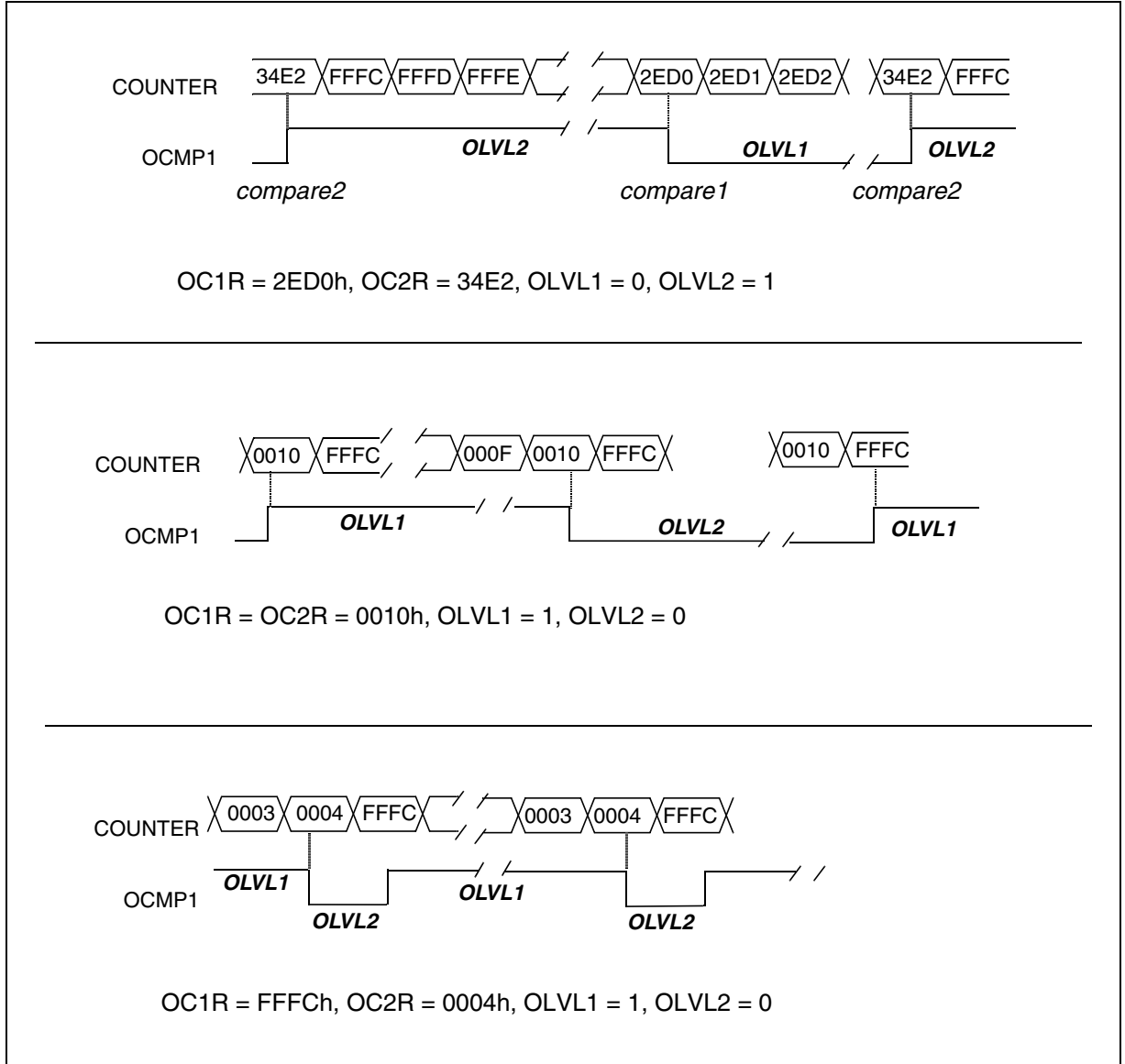

EXTENDED FUNCTION TIMER (Cont'd)**10.3.4 Interrupt Management**

The interrupts of the Extended Function Timer are mapped on one of the eight External Interrupt Channels of the microcontroller (refer to the “Interrupts” chapter).

The three interrupt sources are mapped on the same interrupt channel. To use them, the EFTIS bit must be set)

Each External Interrupt Channel has:

- A trigger control bit in the EITR register (R242 - Page 0),
- A pending bit in the EIPR register (R243 - Page 0),
- A mask bit in the EIMR register (R244 - Page 0).

Program the interrupt priority level using the EIPLR register (R245 - Page 0). For a description of these registers refer to the “Interrupts” and “DMA” chapters.

Using the external interrupt channel for all EFT interrupts

To use the interrupt features, perform the following sequence:

- Set the priority level of the interrupt channel used (EIPLR register)
- Select the interrupt trigger edge as rising edge (set the corresponding bit in the EITR register)
- Set the EFTIS bit of the CR3 register to select the peripheral interrupt sources

- Set the OCIE (or OC1IE/OC2IE bits) and/or ICIE (or IC1IE/IC2IE bits and/or TOIE bit(s) in the CR1 register to enable interrupts
- In the EIPR register, reset the pending bit of the interrupt channel used by the peripheral interrupts to avoid any spurious interrupt requests being performed when the mask bit is set
- Set the mask bits of the interrupt channels used to enable the MCU to acknowledge the interrupt requests of the peripheral.
- Clear all EFT interrupt flags by reading the Status, Input Capture Low, Output Compare Low and Counter Low Registers.

Caution:

1. It is mandatory to clear all EFT interrupt flags simultaneously at least once before exiting an EFT timer interrupt routine (the SR register must = 00h at some point during the interrupt routine), otherwise no interrupts can be issued on that channel anymore.
Refer to the following assembly code for an interrupt sequence example.
2. Since a loop statement is needed inside the IT routine, the user must avoid situations where an interrupt event period is narrower than the duration of the interrupt treatment. Otherwise nested interrupt mode must be used to serve higher priority requests.

EXTENDED FUNCTION TIMER (Cont'd)

Note: A single access (read/write) to the SR register at the beginning of the interrupt routine is the first step needed to clear all the EFT interrupt flags. In a second step, the lower bytes of the data

registers must be accessed if the corresponding flag is set. It is not necessary to access the SR register between these instructions, but it can be done.

```
; INTERRUPT ROUTINE EXAMPLE
    push R234          ; Save current page
    spp #28           ; Set EFT page
L6:
    cp R254,#0        ; while E0_SR is not cleared
    jxz L7
    tm R254,#128      ; Check Input Capture 1 flag
    jxz L2            ; else go to next test
    ld r1,R241        ; Dummy read to clear IC1LR
    ; Insert your code here
L2:
    tm R254,#16       ; Check Input Capture 2 flag
    jxz L3            ; else go to next test
    ld r1,R243        ; Dummy read to clear IC2LR
    ; Insert your code here
L3:
    tm R254,#64       ; Check Input Compare 1 flag
    jxz L4            ; else go to next test
    ld r1,R249        ; Dummy read to clear OC1LR
    ; Insert your code here
L4:
    tm R254,#8        ; Check Input Compare 2 flag
    jxz L5            ; else go to next test
    ld r1,R251        ; Dummy read to clear OC1LR
    ; Insert your code here
L5:
    tm R254,#32       ; Check Input Overflow flag
    jxz L6            ; else go to next test
    ld r1,R245        ; Dummy read to clear Overflow flag
    ; Insert your code here
    jx L6
L7:
    pop R234          ; Restore current page
iret
```

EXTENDED FUNCTION TIMER (Cont'd)

10.3.5 Register Description

Each Timer is associated with three control and one status registers, and with six pairs of data registers (16-bit values) relating to the two input captures, the two output compares, the counter and the alternate counter.

Notes:

1. In the register description on the following pages, register and page numbers are given using the example of Timer 0. On devices with more than one timer, refer to the device register map for the addresses and page numbers.

2. To work correctly with register pairs, it is strongly recommended to use single byte instructions. Do not use word instructions to access any of the 16-bit registers.

INPUT CAPTURE 1 HIGH REGISTER (IC1HR)

R240 - Read Only
 Register Page: 28
 Reset Value: Undefined

This is an 8-bit read only register that contains the high part of the counter value (transferred by the input capture 1 event).



INPUT CAPTURE 1 LOW REGISTER (IC1LR)

R241 - Read Only
 Register Page: 28
 Reset Value: Undefined

This is an 8-bit read only register that contains the low part of the counter value (transferred by the input capture 1 event).

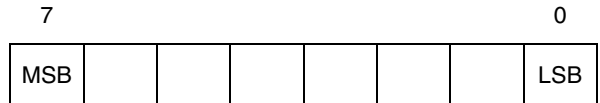

INPUT CAPTURE 2 HIGH REGISTER (IC2HR)

R242 - Read Only
 Register Page: 28
 Reset Value: Undefined

This is an 8-bit read only register that contains the high part of the counter value (transferred by the Input Capture 2 event).



INPUT CAPTURE 2 LOW REGISTER (IC2LR)

R243 - Read Only
 Register Page: 28
 Reset Value: Undefined

This is an 8-bit read only register that contains the low part of the counter value (transferred by the Input Capture 2 event).



EXTENDED FUNCTION TIMER (EFT)

EXTENDED FUNCTION TIMER (Cont'd)

COUNTER HIGH REGISTER (CHR)

R244 - Read Only

Register Page: 28

Reset Value: 1111 1111 (FFh)

This is an 8-bit register that contains the high part of the counter value.



COUNTER LOW REGISTER (CLR)

R245 - Read/Write

Register Page: 28

Reset Value: 1111 1100 (FCh)

This is an 8-bit register that contains the low part of the counter value. A write to this register resets the counter. An access to this register after accessing the SR register clears the TOF bit.



ALTERNATE COUNTER HIGH REGISTER (ACHR)

R246 - Read Only

Register Page: 28

Reset Value: 1111 1111 (FFh)

This is an 8-bit register that contains the high part of the counter value.



ALTERNATE COUNTER LOW REGISTER (ACLR)

R247 - Read/Write

Register Page: 28

Reset Value: 1111 1100 (FCh)

This is an 8-bit register that contains the low part of the counter value. A write to this register resets the counter. An access to this register after an access to SR register does not clear the TOF bit in the SR register.

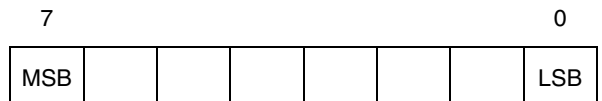

EXTENDED FUNCTION TIMER (Cont'd)

OUTPUT COMPARE 1 HIGH REGISTER (OC1HR)

R248 - Read/Write
 Register Page: 28
 Reset Value: 1000 0000 (80h)

This is an 8-bit register that contains the high part of the value to be compared to the CHR register.



OUTPUT COMPARE 2 HIGH REGISTER (OC2HR)

R250 - Read/Write
 Register Page: 28
 Reset Value: 1000 0000 (80h)

This is an 8-bit register that contains the high part of the value to be compared to the CHR register.

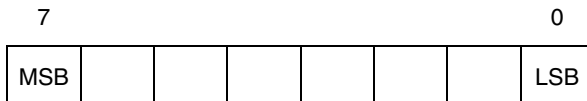

OUTPUT COMPARE 1 LOW REGISTER (OC1LR)

R249 - Read/Write
 Register Page: 28
 Reset Value: 0000 0000 (00h)

This is an 8-bit register that contains the low part of the value to be compared to the CLR register.



OUTPUT COMPARE 2 LOW REGISTER (OC2LR)

R251 - Read/Write
 Register Page: 28
 Reset Value: 0000 0000 (00h)

This is an 8-bit register that contains the low part of the value to be compared to the CLR register.



EXTENDED FUNCTION TIMER (Cont'd)

CONTROL REGISTER 1 (CR1)

R252 - Read/Write

Register Page: 28

Reset Value: 0000 0000 (00h)

7							0
ICIE	OCIE	TOIE	FOLV2	FOLV1	OLVL2	IEDG1	OLVL1

Bit 7 = **ICIE** *Input Capture Interrupt Enable.*

0: Interrupt enabling depends on the IC1IE and IC2IE bits in the CR3 register.

1: An interrupt is generated whenever the ICF1 or ICF2 bit in the SR register is set. The IC1IE and IC2IE bits in the CR3 register do not have any effect in this case.

Bit 6 = **OCIE** *Output Compare Interrupt Enable.*

0: Interrupt generation depends on the OC1IE and OC2IE bits in the CR3 register.

1: An interrupt is generated whenever the OCF1 or OCF2 bit in the SR register is set. The OC1IE and OC2IE bits in the CR3 register do not have any effect in this case.

Bit 5 = **TOIE** *Timer Overflow Interrupt Enable.*

0: Interrupt is inhibited.

1: A timer interrupt is enabled whenever the TOF bit of the SR register is set.

Bit 4 = **FOLV2** *Forced Output Compare 2.*

0: No effect.

1: Forces the OLVL2 bit to be copied to the OCMP2 pin.

Bit 3 = **FOLV1** *Forced Output Compare 1.*

0: No effect.

1: Forces OLVL1 to be copied to the OCMP1 pin.

Bit 2 = **OLVL2** *Output Level 2.*

This bit is copied to the OCMP2 pin whenever a successful comparison occurs with the OC2R register and OC2E is set in the CR2 register. This value is copied to the OCMP1 pin in One Pulse Mode and Pulse Width Modulation mode.

Bit 1 = **IEDG1** *Input Edge 1.*

This bit determines which type of level transition on the ICAP1 pin will trigger the capture.

0: A falling edge triggers the capture.

1: A rising edge triggers the capture.

Bit 0 = **OLVL1** *Output Level 1.*

The OLVL1 bit is copied to the OCMP1 pin whenever a successful comparison occurs with the OC1R register and the OC1E bit is set in the CR2 register.

EXTENDED FUNCTION TIMER (Cont'd)

CONTROL REGISTER 2 (CR2)

R253 - Read/Write

Register Page: 28

Reset Value: 0000 0000 (00h)

7							0
OC1E	OC2E	OPM	PWM	CC1	CC0	IEDG2	EXEDG

Bit 7 = **OC1E Output Compare 1 Enable**.
 0: Output Compare 1 function is enabled, but the OCMP1 pin is a general I/O.
 1: Output Compare 1 function is enabled, the OCMP1 pin is dedicated to the Output Compare 1 capability of the timer.

Bit 6 = **OC2E Output Compare 2 Enable**.
 0: Output Compare 2 function is enabled, but the OCMP2 pin is a general I/O.
 1: Output Compare 2 function is enabled, the OCMP2 pin is dedicated to the Output Compare 2 capability of the timer.

Bit 5 = **OPM One Pulse Mode**.
 0: One Pulse Mode is not active.
 1: One Pulse Mode is active, the ICAP1 pin can be used to trigger one pulse on the OCMP1 pin; the active transition is given by the IEDG1 bit. The length of the generated pulse depends on the contents of the OC1R register.

Bit 4 = **PWM Pulse Width Modulation**.
 0: PWM mode is not active.
 1: PWM mode is active, the OCMP1 pin outputs a programmable cyclic signal; the length of the pulse depends on the value of OC1R register; the period depends on the value of OC2R register.

Bits 3:2 = **CC[1:0] Clock Control**.
 The value of the timer clock depends on these bits:

Table 36. Clock Control Bits

CC1	CC0	Timer Clock
0	0	INTCLK / 4
0	1	INTCLK / 2
1	0	INTCLK / 8
1	1	External Clock

Bit 1 = **IEDG2 Input Edge 2**.
 This bit determines which type of level transition on the ICAP2 pin will trigger the capture.
 0: A falling edge triggers the capture.
 1: A rising edge triggers the capture.

Bit 0 = **EXEDG External Clock Edge**.
 This bit determines which type of level transition on the external clock pin EXTCLK will trigger the free running counter.
 0: A falling edge triggers the free running counter.
 1: A rising edge triggers the free running counter.

EXTENDED FUNCTION TIMER (EFT)

EXTENDED FUNCTION TIMER (Cont'd)

STATUS REGISTER (SR)

R254 - Read Only

Register Page: 28

Reset Value: 0000 0000 (00h)

The three least significant bits are not used.

7							0
ICF1	OCF1	TOF	ICF2	OCF2	0	0	0

Bit 7 = **ICF1** *Input Capture Flag 1.*

0: No input capture (reset value).

1: An input capture has occurred. To clear this bit, first read the SR register, then read or write the low byte of the IC1R (IC1LR) register.

Bit 6 = **OCF1** *Output Compare Flag 1.*

0: No match (reset value).

1: The content of the free running counter has matched the content of the OC1R register. To clear this bit, first read the SR register, then read or write the low byte of the OC1R (OC1LR) register.

Bit 5 = **TOF** *Timer Overflow.*

0: No timer overflow (reset value).

1: The free running counter rolled over from FFFFh to 0000h. To clear this bit, first read the SR register, then read or write the low byte of the CR (CLR) register.

Note: Reading or writing the ACLR register does not clear TOF.

Bit 4 = **ICF2** *Input Capture Flag 2.*

0: No input capture (reset value).

1: An input capture has occurred. To clear this bit, first read the SR register, then read or write the low byte of the IC2R (IC2LR) register.

Bit 3 = **OCF2** *Output Compare Flag 2.*

0: No match (reset value).

1: The content of the free running counter has matched the content of the OC2R register. To clear this bit, first read the SR register, then read or write the low byte of the OC2R (OC2LR) register.

Bit 2:0 = Reserved, forced by hardware to 0.

CONTROL REGISTER 3 (CR3)

R255 - Read/Write

Register Page: 28

Reset Value: 0000 0000 (00h)

7							0
IC1IE	OC1IE	IC2IE	OC2IE	0	0	0	EFTIS

Bit 7 = **IC1IE** *Input Capture1 interrupt enable*

This bit is not significant if the ICIE bit in the CR1 register is set.

0: ICAP1 interrupt disabled

1: ICAP1 interrupt enabled

Bit 6 = **OC1IE** *output compare 1 interrupt enable*

This bit is not significant if the OCIE bit in the CR1 register is set.

0: OCMP1 interrupt disabled

1: OCMP1 interrupt enabled

Bit 5 = **IC2IE** *input capture 2 interrupt enable*

This bit is not significant if the ICIE bit in the CR1 register is set.

0: ICAP2 interrupt disabled

1: ICAP2 interrupt enabled

Bit 4 = **OC2IE** *output compare 2 interrupt enable*

This bit is not significant if the OCIE bit in the CR1 register is set.

0: OCMP2 interrupt disabled

1: OCMP2 interrupt enabled

Bits 3:1 = Reserved, must be kept cleared.

Bit 0 = **EFTIS** *Global Timer Interrupt Selection.*

0: Select External interrupt.

1: Select Global Timer Interrupt.

EXTENDED FUNCTION TIMER (Cont'd)

Table 37. Extended Function Timer Register Map

Address (Dec.)	Register Name	7	6	5	4	3	2	1	0
R240	IC1HR Reset Value	MSB x	x	x	x	x	x	x	LSB x
R241	IC1LR Reset Value	MSB x	x	x	x	x	x	x	LSB x
R242	IC2HR Reset Value	MSB x	x	x	x	x	x	x	LSB x
R243	IC2LR Reset Value	MSB x	x	x	x	x	x	x	LSB x
R244	CHR Reset Value	MSB 1	1	1	1	1	1	1	LSB 1
R245	CLR Reset Value	MSB 1	1	1	1	1	1	0	LSB 0
R246	ACHR Reset Value	MSB 1	1	1	1	1	1	1	LSB 1
R247	ACL Reset Value	MSB 1	1	1	1	1	1	0	LSB 0
R248	OC1HR Reset Value	MSB 1	0	0	0	0	0	0	LSB 0
R249	OC1LR Reset Value	MSB 0	0	0	0	0	0	0	LSB 0
R250	OC2HR Reset Value	MSB 1	0	0	0	0	0	0	LSB 0
R251	OC2LR Reset Value	MSB 0	0	0	0	0	0	0	LSB 0
R252	CR1 Reset Value	OC1E 0	OC2E 0	OPM 0	PWM 0	CC1 0	CC0 0	IEDG2 0	EXEDG 0
R253	CR2 Reset Value	ICIE 0	OCIE 0	TOIE 0	FOLV2 0	FOLV1 0	OLVL2 0	IEDG1 0	OLVL1 0
R254	SR Reset Value	ICF1 0	OCF1 0	TOF 0	ICF2 0	OCF2 0	- 0	- 0	- 0
R255	CR3 Reset Value	IC1IE 0	OC1IE 0	IC2IE 0	OC2IE 0	- 0	- 0	- 0	EFTIS 0

10.4 MULTIFUNCTION TIMER (MFT)

10.4.1 Introduction

The Multifunction Timer (MFT) peripheral offers powerful timing capabilities and features 12 operating modes, including automatic PWM generation and frequency measurement.

The MFT comprises a 16-bit Up/Down counter driven by an 8-bit programmable prescaler. The input clock may be INTCLK/3 or an external source. The timer features two 16-bit Comparison Registers, and two 16-bit Capture/Load/Reload Registers. Two input pins and two alternate function output pins are available.

Several functional configurations are possible, for instance:

- 2 input captures on separate external lines, and 2 independent output compare functions with the counter in free-running mode, or 1 output compare at a fixed repetition rate.

- 1 input capture, 1 counter reload and 2 independent output compares.
- 2 alternate autoreloads and 2 independent output compares.
- 2 alternate captures on the same external line and 2 independent output compares at a fixed repetition rate.

When two MFTs are present in an ST9 device, a combined operating mode is available.

An internal On-Chip Event signal can be used on some devices to control other on-chip peripherals.

The two external inputs may be individually programmed to detect any of the following:

- rising edges
- falling edges
- both rising and falling edges

Figure 101. MFT Simplified Block Diagram

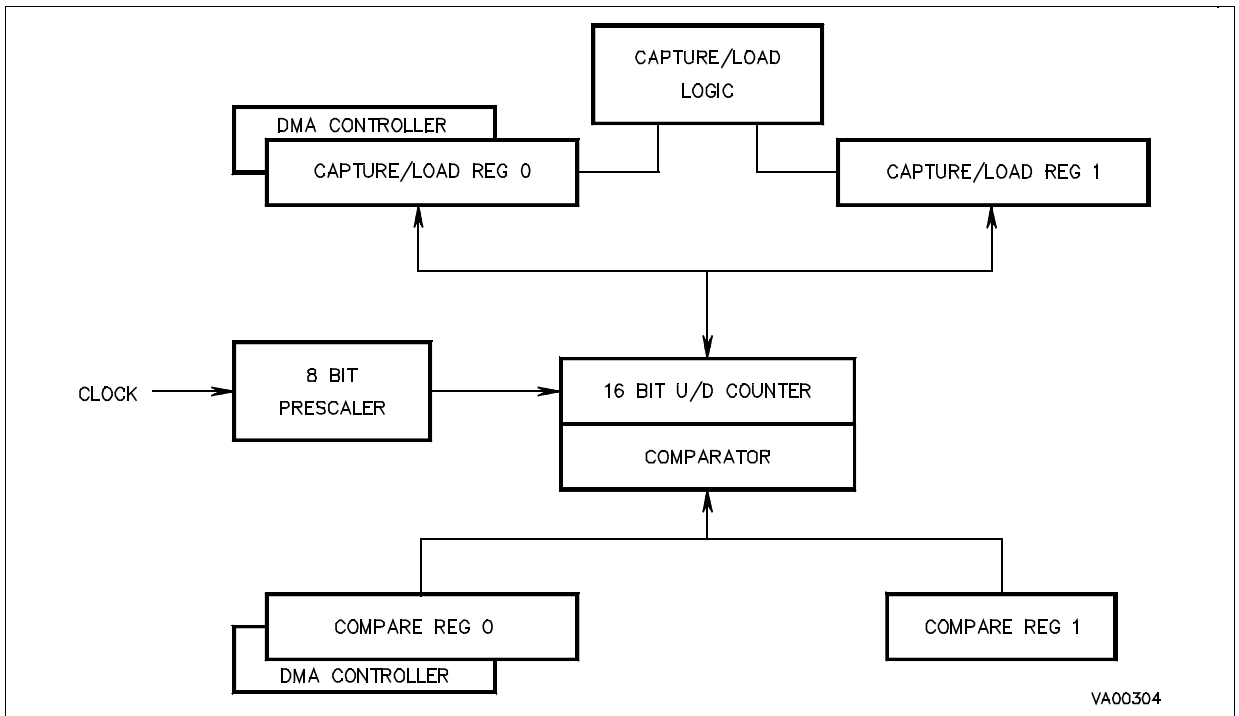

VA00304

MULTIFUNCTION TIMER (Cont'd)

The configuration of each input is programmed in the Input Control Register.

Each of the two output pins can be driven from any of three possible sources:

- Compare Register 0 logic
- Compare Register 1 logic
- Overflow/Underflow logic

Each of these three sources can cause one of the following four actions, independently, on each of the two outputs:

- Nop, Set, Reset, Toggle

In addition, an additional On-Chip Event signal can be generated by two of the three sources mentioned above, i.e. Over/Underflow event and Compare 0 event. This signal can be used internally to

synchronise another on-chip peripheral. Five maskable interrupt sources referring to an End Of Count condition, 2 input captures and 2 output compares, can generate 3 different interrupt requests (with hardware fixed priority), pointing to 3 interrupt routine vectors.

Two independent DMA channels are available for rapid data transfer operations. Each DMA request (associated with a capture on the REG0R register, or with a compare on the CMP0R register) has priority over an interrupt request generated by the same source.

A SWAP mode is also available to allow high speed continuous transfers (see Interrupt and DMA chapter).

Figure 102. Detailed Block Diagram

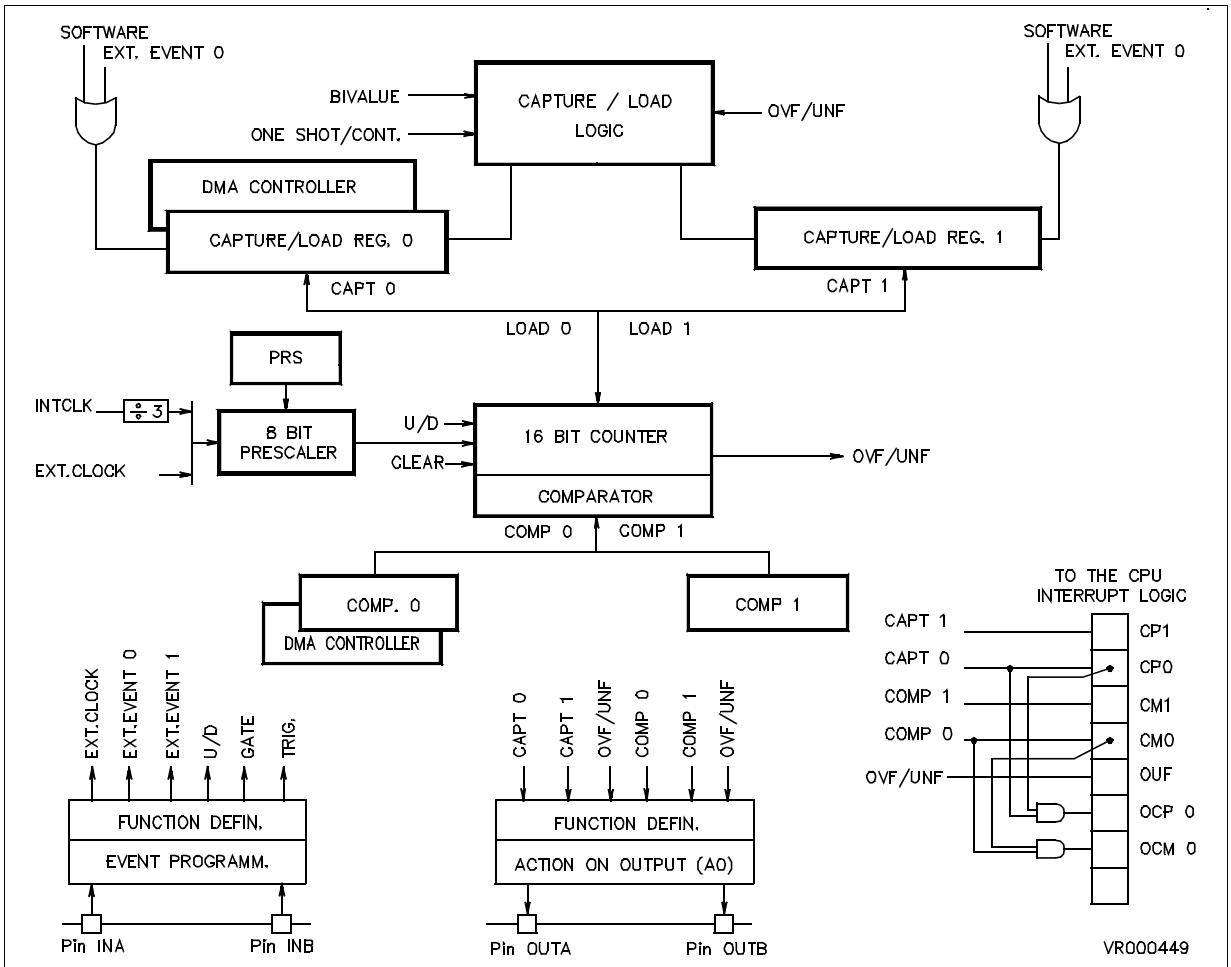

MULTIFUNCTION TIMER (Cont'd)

10.4.2 Functional Description

The MFT operating modes are selected by programming the Timer Control Register (TCR) and the Timer Mode Register (TMR).

10.4.2.1 Trigger Events

A trigger event may be generated by software (by setting either the CP0 or the CP1 bits in the T_FLAGR register) or by an external source which may be programmed to respond to the rising edge, the falling edge or both by programming bits A0-A1 and B0-B1 in the T_ICR register. This trigger event can be used to perform a capture or a load, depending on the Timer mode (configured using the bits in [Table 41](#)).

An event on the TxINA input or setting the CP0 bit triggers a capture to, or a load from the REG0R register (except in Bicapture mode, see [Section 10.4.2.11](#)).

An event on the TxINB input or setting the CP1 bit triggers a capture to, or a load from the REG1R register.

In addition, in the special case of "Load from REG0R and monitor on REG1R", it is possible to use the TxINB input as a trigger for REG0R."

10.4.2.2 One Shot Mode

When the counter generates an overflow (in up-count mode), or an underflow (in down-count mode), that is to say when an End Of Count condition is reached, the counter stops and no counter reload occurs. The counter may only be restarted by an external trigger on TxINA or B or a by software trigger on CP0 only. One Shot Mode is entered by setting the CO bit in TMR.

10.4.2.3 Continuous Mode

Whenever the counter reaches an End Of Count condition, the counting sequence is automatically restarted and the counter is reloaded from REG0R (or from REG1R, when selected in Biload Mode). Continuous Mode is entered by resetting the CO bit in TMR.

10.4.2.4 Triggered And Retriggered Modes

A triggered event may be generated by software (by setting either the CP0 or the CP1 bit in the T_FLAGR register), or by an external source

which may be programmed to respond to the rising edge, the falling edge or both, by programming bits A0-A1 and B0-B1 in T_ICR.

In One Shot and Triggered Mode, every trigger event arriving before an End Of Count, is masked. In One Shot and Retriggered Mode, every trigger received while the counter is running, automatically reloads the counter from REG0R. Triggered/Retriggered Mode is set by the REN bit in TMR.

The TxINA input refers to REG0R and the TxINB input refers to REG1R.

WARNING. If the Triggered Mode is selected when the counter is in Continuous Mode, every trigger is disabled, it is not therefore possible to synchronise the counting cycle by hardware or software.

10.4.2.5 Gated Mode

In this mode, counting takes place only when the external gate input is at a logic low level. The selection of TxINA or TxINB as the gate input is made by programming the IN0-IN3 bits in T_ICR.

10.4.2.6 Capture Mode

The REG0R and REG1R registers may be independently set in Capture Mode by setting RM0 or RM1 in TMR, so that a capture of the current count value can be performed either on REG0R or on REG1R, initiated by software (by setting CP0 or CP1 in the T_FLAGR register) or by an event on the external input pins.

WARNING. Care should be taken when two software captures are to be performed on the same register. In this case, at least one instruction must be present between the first CP0/CP1 bit set and the subsequent CP0/CP1 bit reset instructions.

10.4.2.7 Up/Down Mode

The counter can count up or down depending on the state of the UDC bit (Up/Down Count) in TCR, or on the configuration of the external input pins, which have priority over UDC (see Input pin assignment in T_ICR). The UDCS bit returns the counter up/down current status (see also the Up/Down Autodiscrimination mode in the Input Pin Assignment Section).

MULTIFUNCTION TIMER (Cont'd)

10.4.2.8 Free Running Mode

The timer counts continuously (in Up or Down mode) and the counter value simply overflows or underflows through FFFFh or zero; there is no End Of Count condition as such, and no reloading takes place. This mode is automatically selected either in Bi-capture mode or by setting register REG0R for a Capture function (Continuous mode must also be set). In Autoclear mode, free running operation can be selected, with the possibility of choosing a maximum count value less than 2^{16} before overflow or underflow (see Autoclear mode).

10.4.2.9 Monitor Mode

When the RM1 bit in TMR is reset, and the timer is not in Bi-value mode, REG1R acts as a monitor, duplicating the current up or down counter contents, thus allowing the counter to be read “on the fly”.

10.4.2.10 Autoclear Mode

A clear command forces the counter either to 0000h or to FFFFh, depending on whether up-counting or downcounting is selected. The counter reset may be obtained either directly, through the CCL bit in TCR, or by entering the Autoclear Mode, through the CCP0 and CCMP0 bits in TCR.

Every capture performed on REG0R (if CCP0 is set), or every successful compare performed by CMP0R (if CCMP0 is set), clears the counter and reloads the prescaler.

The Clear On Capture mode allows direct measurement of delta time between successive captures on REG0R, while the Clear On Compare mode allows free running with the possibility of choosing a maximum count value before overflow or underflow which is less than 2^{16} (see Free Running Mode).

10.4.2.11 Bi-value Mode

Depending on the value of the RM0 bit in TMR, the Bi-load Mode (RM0 reset) or the Bi-capture Mode (RM0 set) can be selected as illustrated in [Figure 38](#) below:

Table 38. Bi-value Modes

TMR bits			Timer Operating Modes
RM0	RM1	BM	
0	X	1	Bi-Load mode
1	X	1	Bi-Capture Mode

A) Biload Mode

The Bi-load Mode is entered by selecting the Bi-value Mode (BM set in TMR) and programming REG0R as a reload register (RM0 reset in TMR).

At any End Of Count, counter reloading is performed alternately from REG0R and REG1R, (a low level for BM bit always sets REG0R as the current register, so that, after a Low to High transition of BM bit, the first reload is always from REG0R).

MULTIFUNCTION TIMER (Cont'd)

Every software or external trigger event on REG0R performs a reload from REG0R resetting the Biloard cycle. In One Shot mode (reload initiated by software or by an external trigger), reloading is always from REG0R.

B) Bicapture Mode

The Bicapture Mode is entered by selecting the Bi-value Mode (the BM bit in TMR is set) and by programming REG0R as a capture register (the RMO bit in TMR is set).

Interrupt generation can be configured as an AND or OR function of the two Capture events. This is configured by the A0 bit in the T_FLAGR register.

Every capture event, software simulated (by setting the CP0 flag) or coming directly from the TxINA input line, captures the current counter value alternately into REG0R and REG1R. When the BM bit is reset, REG0R is the current register, so that the first capture, after resetting the BM bit, is always into REG0R.

10.4.2.12 Parallel Mode

When two MFTs are present on an ST9 device, the parallel mode is entered when the ECK bit in the TMR register of Timer 1 is set. The Timer 1 prescaler input is internally connected to the Timer 0 prescaler output. Timer 0 prescaler input is connected to the system clock line.

By loading the Prescaler Register of Timer 1 with the value 00h the two timers (Timer 0 and Timer 1) are driven by the same frequency in parallel mode. In this mode the clock frequency may be divided by a factor in the range from 1 to 2^{16} .

10.4.2.13 Autodiscriminator Mode

The phase difference sign of two overlapping pulses (respectively on TxINB and TxINA) generates a one step up/down count, so that the up/down control and the counter clock are both external. The setting of the UDC bit in the TCR register has no effect in this configuration.

Figure 103. Parallel Mode Description

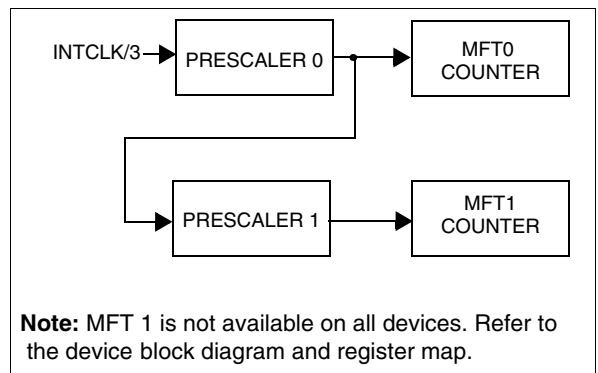

MULTIFUNCTION TIMER (Cont'd)

10.4.3 Input Pin Assignment

The two external inputs (TxINA and TxINB) of the timer can be individually configured to catch a particular external event (i.e. rising edge, falling edge, or both rising and falling edges) by programming the two relevant bits (A0, A1 and B0, B1) for each input in the external Input Control Register (T_ICR).

The 16 different functional modes of the two external inputs can be selected by programming bits IN0 - IN3 of the T_ICR, as illustrated in [Figure 39](#)

Table 39. Input Pin Function

I C Reg. IN3-IN0 bits	TxINA Input Function	TxINB Input Function
0000	not used	not used
0001	not used	Trigger
0010	Gate	not used
0011	Gate	Trigger
0100	not used	Ext. Clock
0101	Trigger	not used
0110	Gate	Ext. Clock
0111	Trigger	Trigger
1000	Clock Up	Clock Down
1001	Up/Down	Ext. Clock
1010	Trigger Up	Trigger Down
1011	Up/Down	not used
1100	Autodiscr.	Autodiscr.
1101	Trigger	Ext. Clock
1110	Ext. Clock	Trigger
1111	Trigger	Gate

Some choices relating to the external input pin assignment are defined in conjunction with the RM0 and RM1 bits in TMR.

For input pin assignment codes which use the input pins as Trigger Inputs (except for code 1010, Trigger Up:Trigger Down), the following conditions apply:

- a trigger signal on the TxINA input pin performs an U/D counter load if RM0 is reset, or an external capture if RM0 is set.
- a trigger signal on the TxINB input pin always performs an external capture on REG1R. The TxINB input pin is disabled when the Bivalve Mode is set.

Note: For proper operation of the External Input pins, the following must be observed:

- the minimum external clock/trigger pulse width must not be less than the system clock (INTCLK) period if the input pin is programmed as rising or falling edge sensitive.
- the minimum external clock/trigger pulse width must not be less than the prescaler clock period (INTCLK/3) if the input pin is programmed as rising and falling edge sensitive (valid also in Auto discrimination mode).
- the minimum delay between two clock/trigger pulse active edges must be greater than the prescaler clock period (INTCLK/3), while the minimum delay between two consecutive clock/trigger pulses must be greater than the system clock (INTCLK) period.
- the minimum gate pulse width must be at least twice the prescaler clock period (INTCLK/3).
- in Autodiscrimination mode, the minimum delay between the input pin A pulse edge and the edge of the input pin B pulse, must be at least equal to the system clock (INTCLK) period.
- if a number, N, of external pulses must be counted using a Compare Register in External Clock mode, then the Compare Register must be loaded with the value $[X +/- (N-1)]$, where X is the starting counter value and the sign is chosen depending on whether Up or Down count mode is selected.

MULTIFUNCTION TIMER (Cont'd)

10.4.3.1 TxINA = I/O - TxINB = I/O

Input pins A and B are not used by the Timer. The counter clock is internally generated and the up/down selection may be made only by software via the UDC (Software Up/Down) bit in the TCR register.

10.4.3.2 TxINA = I/O - TxINB = Trigger

The signal applied to input pin B acts as a trigger signal on REG1R register. The prescaler clock is internally generated and the up/down selection may be made only by software via the UDC (Software Up/Down) bit in the TCR register.

10.4.3.3 TxINA = Gate - TxINB = I/O

The signal applied to input pin A acts as a gate signal for the internal clock (i.e. the counter runs only when the gate signal is at a low level). The counter clock is internally generated and the up/down control may be made only by software via the UDC (Software Up/Down) bit in the TCR register.

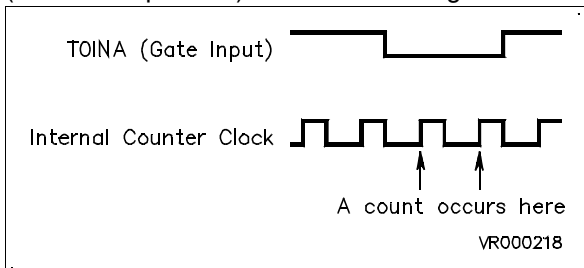

10.4.3.4 TxINA = Gate - TxINB = Trigger

Both input pins A and B are connected to the timer, with the resulting effect of combining the actions relating to the previously described configurations.

10.4.3.5 TxINA = I/O - TxINB = Ext. Clock

The signal applied to input pin B is used as the external clock for the prescaler. The up/down selection may be made only by software via the UDC (Software Up/Down) bit in the TCR register.

10.4.3.6 TxINA = Trigger - TxINB = I/O

The signal applied to input pin A acts as a trigger for REG0R, initiating the action for which the reg-

ister was programmed (i.e. a reload or capture). The prescaler clock is internally generated and the up/down selection may be made only by software via the UDC (Software Up/Down) bit in the TCR register.

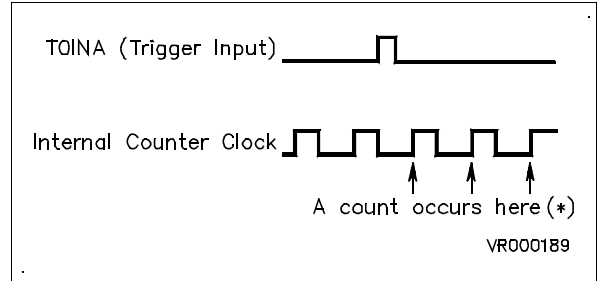

(*) The timer is in One shot mode and REGOR in Reload mode

10.4.3.7 TxINA = Gate - TxINB = Ext. Clock

The signal applied to input pin B, gated by the signal applied to input pin A, acts as external clock for the prescaler. The up/down control may be made only by software action through the UDC bit in the TCR register.

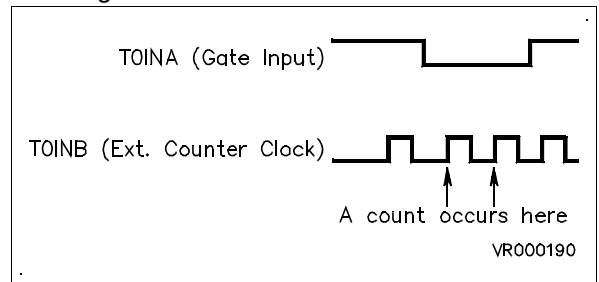

10.4.3.8 TxINA = Trigger - TxINB = Trigger

The signal applied to input pin A (or B) acts as trigger signal for REG0R (or REG1R), initiating the action for which the register has been programmed. The counter clock is internally generated and the up/down selection may be made only by software via the UDC (Software Up/Down) bit in the TCR register.

MULTIFUNCTION TIMER (Cont'd)

10.4.3.9 TxINA = Clock Up - TxINB = Clock Down

The edge received on input pin A (or B) performs a one step up (or down) count, so that the counter clock and the up/down control are external. Setting the UDC bit in the TCR register has no effect in this configuration, and input pin B has priority on input pin A.

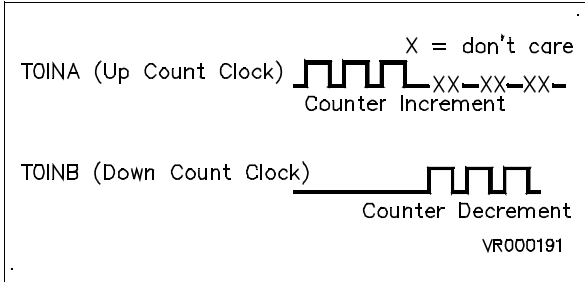

10.4.3.11 TxINA = Trigger Up - TxINB = Trigger Down

Up/down control is performed through both input pins A and B. A edge on input pin A sets the up count mode, while a edge on input pin B (which has priority on input pin A) sets the down count mode. The counter clock is internally generated, and setting the UDC bit in the TCR register has no effect in this configuration.

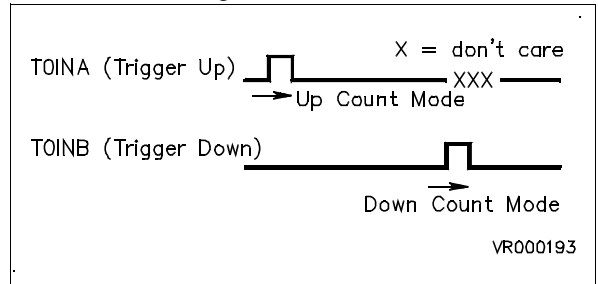

10.4.3.10 TxINA = Up/Down - TxINB = Ext Clock

An High (or Low) level applied to input pin A sets the counter in the up (or down) count mode, while the signal applied to input pin B is used as clock for the prescaler. Setting the UDC bit in the TCR register has no effect in this configuration.

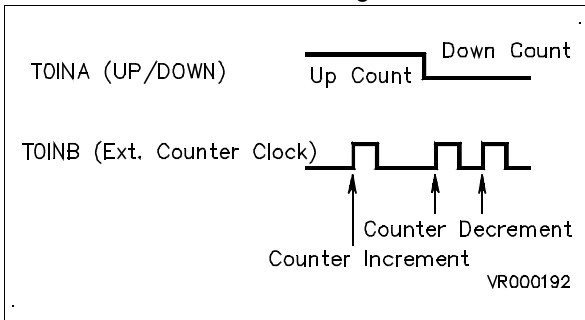

10.4.3.12 TxINA = Up/Down - TxINB = I/O

An High (or Low) level of the signal applied on input pin A sets the counter in the up (or down) count mode. The counter clock is internally generated. Setting the UDC bit in the TCR register has no effect in this configuration.

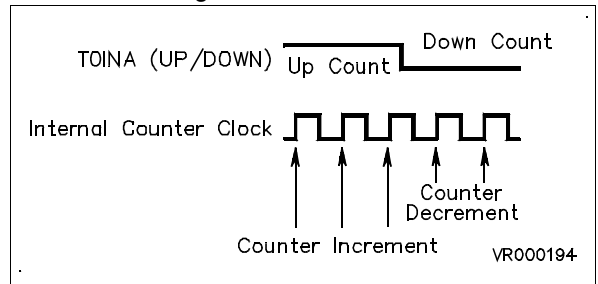

MULTIFUNCTION TIMER (Cont'd)

10.4.3.13 Autodiscrimination Mode

The phase between two pulses (respectively on input pin B and input pin A) generates a one step up (or down) count, so that the up/down control and the counter clock are both external. Thus, if the rising edge of TxINB arrives when TxINA is at a low level, the timer is incremented (no action if the rising edge of TxINB arrives when TxINA is at a high level). If the falling edge of TxINB arrives when TxINA is at a low level, the timer is decremented (no action if the falling edge of TxINB arrives when TxINA is at a high level).

Setting the UDC bit in the TCR register has no effect in this configuration.

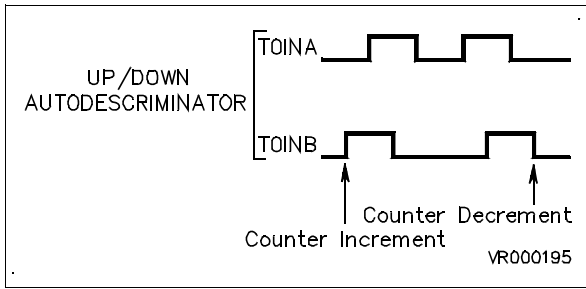

10.4.3.14 TxINA = Trigger - TxINB = Ext. Clock

The signal applied to input pin A acts as a trigger signal on REG0R, initiating the action for which the register was programmed (i.e. a reload or cap-

ture), while the signal applied to input pin B is used as the clock for the prescaler.

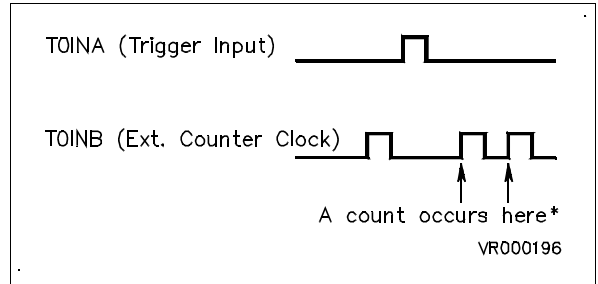

(*) The timer is in One shot mode and REG0R in reload mode

10.4.3.15 TxINA = Ext. Clock - TxINB = Trigger

The signal applied to input pin B acts as a trigger, performing a capture on REG1R, while the signal applied to input pin A is used as the clock for the prescaler.

10.4.3.16 TxINA = Trigger - TxINB = Gate

The signal applied to input pin A acts as a trigger signal on REG0R, initiating the action for which the register was programmed (i.e. a reload or capture), while the signal applied to input pin B acts as a gate signal for the internal clock (i.e. the counter runs only when the gate signal is at a low level).

MULTIFUNCTION TIMER (Cont'd)

10.4.4 Output Pin Assignment

Two external outputs are available when programmed as Alternate Function Outputs of the I/O pins.

Two registers Output A Control Register (OACR) and Output B Control Register (OBCR) define the driver for the outputs and the actions to be performed.

Each of the two output pins can be driven from any of the three possible sources:

- Compare Register 0 event logic
- Compare Register 1 event logic
- Overflow/Underflow event logic.

Each of these three sources can cause one of the following four actions on any of the two outputs:

- Nop
- Set
- Reset
- Toggle

Furthermore an On Chip Event signal can be driven by two of the three sources: the Over/Underflow event and Compare 0 event by programming the CEV bit of the OACR register and the OEV bit of OBCR register respectively. This signal can be used internally to synchronise another on-chip peripheral.

Output Waveforms

Depending on the programming of OACR and OBCR, the following example waveforms can be generated on TxOUTA and TxOUTB pins.

For a configuration where TxOUTA is driven by the Over/Underflow (OUF) and the Compare 0 event (CM0), and TxOUTB is driven by the Over/Underflow and Compare 1 event (CM1):

OACR is programmed with TxOUTA preset to "0", OUF sets TxOUTA, CM0 resets TxOUTA and CM1 does not affect the output. OBCR is programmed with TxOUTB preset to "0", OUF sets TxOUTB, CM1 resets TxOUTB while CM0 does not affect the output.

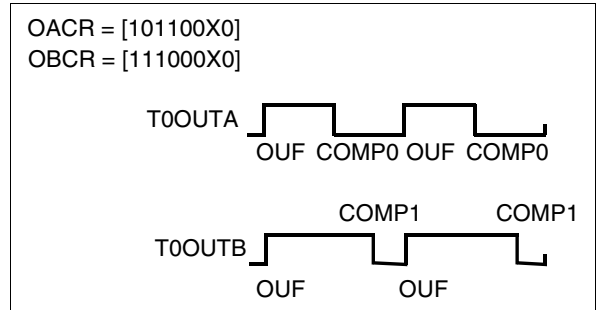

For a configuration where TxOUTA is driven by the Over/Underflow, by Compare 0 and by Compare 1; TxOUTB is driven by both Compare 0 and Compare 1. OACR is programmed with TxOUTA preset to "0". OUF toggles Output 0, as do CM0 and CM1. OBCR is programmed with TxOUTB preset to "1". OUF does not affect the output; CM0 resets TxOUTB and CM1 sets it.

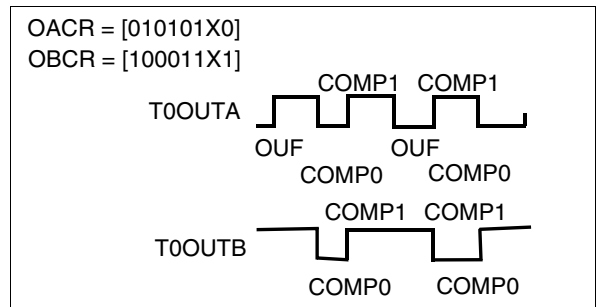

MULTIFUNCTION TIMER (Cont'd)

For a configuration where TxOUTA is driven by the Over/Underflow and by Compare 0, and TxOUTB is driven by the Over/Underflow and by Compare 1. OACR is programmed with TxOUTA preset to "0". OUF sets TxOUTA while CM0 resets it, and CM1 has no effect. OBCR is programmed with TxOUTB preset to "1". OUF toggles TxOUTB, CM1 sets it and CM0 has no effect.

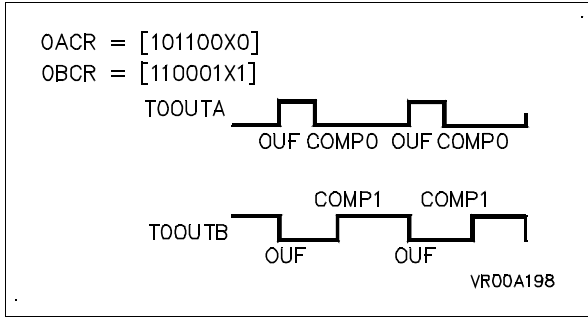

For a configuration where TxOUTA is driven by the Over/Underflow and by Compare 0, and TxOUTB is driven by Compare 0 and 1. OACR is programmed with TxOUTA preset to "0". OUF sets TxOUTA, CM0 resets it and CM1 has no effect. OBCR is programmed with TxOUTB preset to "0". OUF has no effect, CM0 sets TxOUTB and CM1 toggles it.

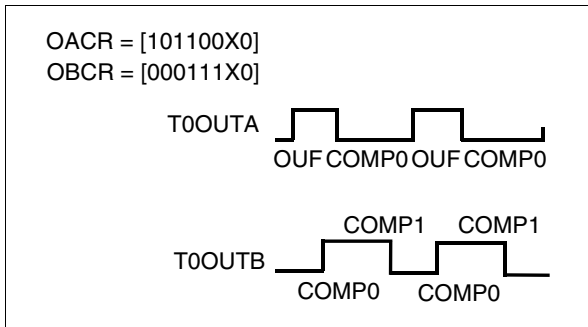

Output Waveform Samples In Biload Mode

TxOUTA is programmed to monitor the two time intervals, t1 and t2, of the Biload Mode, while TxOUTB is independent of the Over/Underflow and is driven by the different values of Compare 0 and Compare 1. OACR is programmed with TxOUTA preset to "0". OUF toggles the output and CM0 and CM1 do not affect TxOUTA. OBCR is programmed with TxOUTB preset to "0". OUF has no effect, while CM1 resets TxOUTB and CM0 sets it.

Depending on the CM1/CM0 values, three different sample waveforms have been drawn based on the above mentioned configuration of OBCR. In the last case, with a different programmed value of OBCR, only Compare 0 drives TxOUTB, toggling the output.

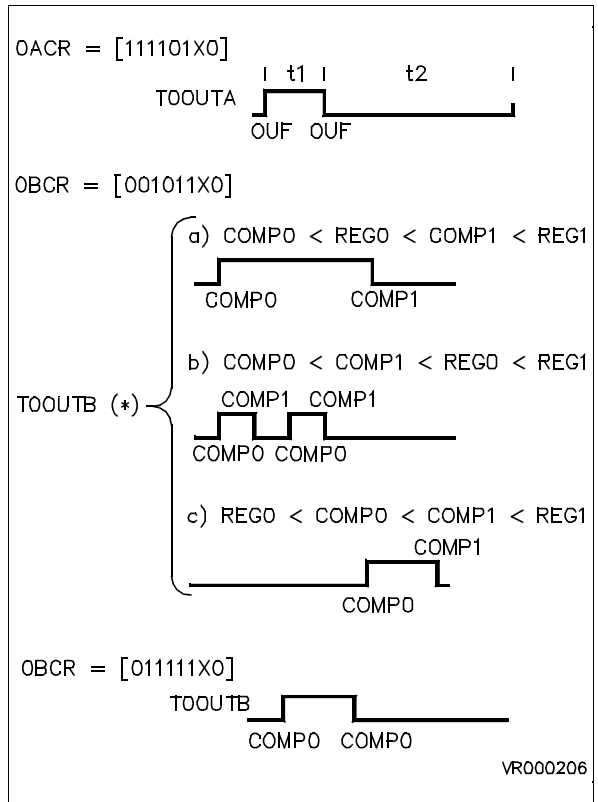

Note (*) Depending on the CMP1R/CMP0R values

MULTIFUNCTION TIMER (Cont'd)

10.4.5 Interrupt and DMA

10.4.5.1 Timer Interrupt

The timer has 5 different Interrupt sources, belonging to 3 independent groups, which are assigned to the following Interrupt vectors:

Table 40. Timer Interrupt Structure

Interrupt Source	Vector Address
COMP 0 COMP 1	xxxx x110
CAPT 0 CAPT 1	xxxx x100
Overflow/Underflow	xxxx x000

The three least significant bits of the vector pointer address represent the relative priority assigned to each group, where 000 represents the highest priority level. These relative priorities are fixed by hardware, according to the source which generates the interrupt request. The 5 most significant bits represent the general priority and are programmed by the user in the Interrupt Vector Register (T_IVR).

Each source can be masked by a dedicated bit in the Interrupt/DMA Mask Register (IDMR) of each timer, as well as by a global mask enable bit (IDMR.7) which masks all interrupts.

If an interrupt request (CM0 or CP0) is present before the corresponding pending bit is reset, an overrun condition occurs. This condition is flagged in two dedicated overrun bits, relating to the Comp0 and Capt0 sources, in the Timer Flag Register (T_FLAGR).

10.4.5.2 Timer DMA

Two Independent DMA channels, associated with Comp0 and Capt0 respectively, allow DMA transfers from Register File or Memory to the Comp0 Register, and from the Capt0 Register to Register File or Memory). If DMA is enabled, the Capt0 and Comp0 interrupts are generated by the corresponding DMA End of Block event. Their priority is set by hardware as follows:

- Compare 0 Destination — Lower Priority
- Capture 0 Source — Higher Priority

The two DMA request sources are independently maskable by the CP0D and CM0D DMA Mask bits in the IDMR register.

The two DMA End of Block interrupts are independently enabled by the CP0I and CM0I Interrupt mask bits in the IDMR register.

10.4.5.3 DMA Pointers

The 6 programmable most significant bits of the DMA Counter Pointer Register (DCPR) and of the DMA Address Pointer Register (DAPR) are common to both channels (Comp0 and Capt0). The Comp0 and Capt0 Address Pointers are mapped as a pair in the Register File, as are the Comp0 and Capt0 DMA Counter pair.

In order to specify either the Capt0 or the Comp0 pointers, according to the channel being serviced, the Timer resets address bit 1 for CAPT0 and sets it for COMP0, when the D0 bit in the DCPR register is equal to zero (Word address in Register File). In this case (transfers between peripheral registers and memory), the pointers are split into two groups of adjacent Address and Counter pairs respectively.

For peripheral register to register transfers (selected by programming “1” into bit 0 of the DCPR register), only one pair of pointers is required, and the pointers are mapped into one group of adjacent positions.

The DMA Address Pointer Register (DAPR) is not used in this case, but must be considered reserved.

Figure 104. Pointer Mapping for Transfers between Registers and Memory

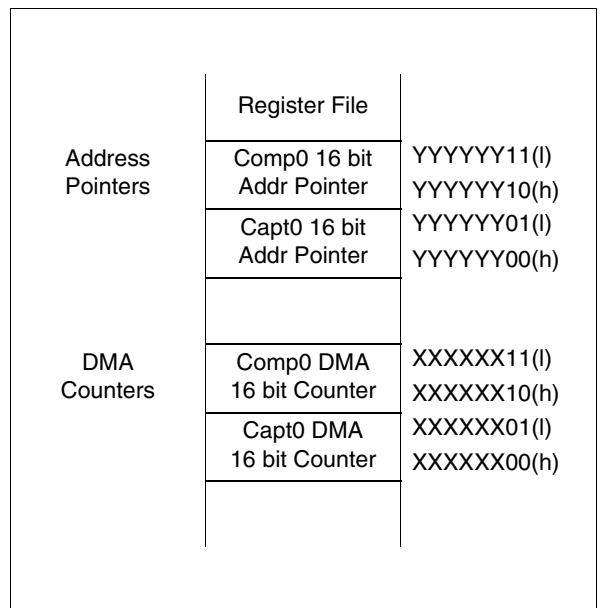

MULTIFUNCTION TIMER (Cont'd)

Figure 105. Pointer Mapping for Register to Register Transfers

Register File		
8 bit Counter	XXXXXX11	Compare 0
8 bit Addr Pointer	XXXXXX10	
8 bit Counter	XXXXXX01	Capture 0
8 bit Addr Pointer	XXXXXX00	

10.4.5.4 DMA Transaction Priorities

Each Timer DMA transaction is a 16-bit operation, therefore two bytes must be transferred sequentially, by means of two DMA transfers. In order to speed up each word transfer, the second byte transfer is executed by automatically forcing the peripheral priority to the highest level (000), regardless of the previously set level. It is then restored to its original value after executing the transfer. Thus, once a request is being serviced, its hardware priority is kept at the highest level regardless of the other Timer internal sources, i.e. once a Comp0 request is being serviced, it maintains a higher priority, even if a Capt0 request occurs between the two byte transfers.

10.4.5.5 DMA Swap Mode

After a complete data table transfer, the transaction counter is reset and an End Of Block (EOB) condition occurs, the block transfer is completed.

The End Of Block Interrupt routine must at this point reload both address and counter pointers of the channel referred to by the End Of Block interrupt source, if the application requires a continuous high speed data flow. This procedure causes speed limitations because of the time required for the reload routine.

The SWAP feature overcomes this drawback, allowing high speed continuous transfers. Bit 2 of the DMA Counter Pointer Register (DCPR) and of the DMA Address Pointer Register (DAPR), toggles after every End Of Block condition, alternately providing odd and even address (D2-D7) for the pair of pointers, thus pointing to an updated pair, after a block has been completely transferred. This allows the User to update or read the first block and to update the pointer values while the second is being transferred. These two toggle bits are software writable and readable, mapped in DCPR bit 2 for the CM0 channel, and in DAPR bit 2 for the CP0 channel (though a DMA event on a channel, in Swap mode, modifies a field in DAPR and DCPR common to both channels, the DAPR/DCPR content used in the transfer is always the bit related to the correct channel).

SWAP mode can be enabled by the SWEN bit in the IDCR Register.

WARNING: Enabling SWAP mode affects both channels (CM0 and CP0).

MULTIFUNCTION TIMER (Cont'd)

10.4.5.6 DMA End Of Block Interrupt Routine

An interrupt request is generated after each block transfer (EOB) and its priority is the same as that assigned in the usual interrupt request, for the two channels. As a consequence, they will be serviced only when no DMA request occurs, and will be subject to a possible OUF Interrupt request, which has higher priority.

The following is a typical EOB procedure (with swap mode enabled):

- Test Toggle bit and Jump.
- Reload Pointers (odd or even depending on toggle bit status).
- Reset EOB bit: this bit must be reset only after the old pair of pointers has been restored, so that, if a new EOB condition occurs, the next pair of pointers is ready for swapping.
- Verify the software protection condition (see [Section 10.4.5.7](#)).
- Read the corresponding Overrun bit: this confirms that no DMA request has been lost in the meantime.
- Reset the corresponding pending bit.
- Reenable DMA with the corresponding DMA mask bit (**must always be done after resetting the pending bit**)

– Return.

WARNING: The EOB bits are read/write **only** for test purposes. Writing a logical “1” by software (when the SWEN bit is set) will cause a spurious interrupt request. These bits are normally only reset by software.

10.4.5.7 DMA Software Protection

A second EOB condition may occur before the first EOB routine is completed, this would cause a not yet updated pointer pair to be addressed, with consequent overwriting of memory. To prevent these errors, a protection mechanism is provided, such that the attempted setting of the EOB bit before it has been reset by software will cause the DMA mask on that channel to be reset (DMA disabled), thus blocking any further DMA operation. As shown above, this mask bit should always be checked in each EOB routine, to ensure that all DMA transfers are properly served.

10.4.6 Register Description

Note: In the register description on the following pages, register and page numbers are given using the example of Timer 0. On devices with more than one timer, refer to the device register map for the addresses and page numbers.

MULTIFUNCTION TIMER (MFT)

MULTIFUNCTION TIMER (Cont'd)

CAPTURE LOAD 0 HIGH REGISTER (REG0HR)

R240 - Read/Write
Register Page: 10
Reset value: undefined

7								0
R15	R14	R13	R12	R11	R10	R9	R8	

This register is used to capture values from the Up/Down counter or load preset values (MSB).

CAPTURE LOAD 0 LOW REGISTER (REG0LR)

R241 - Read/Write
Register Page: 10
Reset value: undefined

7								0
R7	R6	R5	R4	R3	R2	R1	R0	

This register is used to capture values from the Up/Down counter or load preset values (LSB).

CAPTURE LOAD 1 HIGH REGISTER (REG1HR)

R242 - Read/Write
Register Page: 10
Reset value: undefined

7								0
R15	R14	R13	R12	R11	R10	R9	R8	

This register is used to capture values from the Up/Down counter or load preset values (MSB).

CAPTURE LOAD 1 LOW REGISTER (REG1LR)

R243 - Read/Write
Register Page: 10
Reset value: undefined

7								0
R7	R6	R5	R4	R3	R2	R1	R0	

This register is used to capture values from the Up/Down counter or load preset values (LSB).

COMPARE 0 HIGH REGISTER (CMP0HR)

R244 - Read/Write
Register Page: 10
Reset value: 0000 0000 (00h)

7								0
R15	R14	R13	R12	R11	R10	R9	R8	

This register is used to store the MSB of the 16-bit value to be compared to the Up/Down counter content.

COMPARE 0 LOW REGISTER (CMP0LR)

R245 - Read/Write
Register Page: 10
Reset value: 0000 0000 (00h)

7								0
R7	R6	R5	R4	R3	R2	R1	R0	

This register is used to store the LSB of the 16-bit value to be compared to the Up/Down counter content.

COMPARE 1 HIGH REGISTER (CMP1HR)

R246 - Read/Write
Register Page: 10
Reset value: 0000 0000 (00h)

7								0
R15	R14	R13	R12	R11	R10	R9	R8	

This register is used to store the MSB of the 16-bit value to be compared to the Up/Down counter content.

COMPARE 1 LOW REGISTER (CMP1LR)

R247 - Read/Write
Register Page: 10
Reset value: 0000 0000 (00h)

7								0
R7	R6	R5	R4	R3	R2	R1	R0	

This register is used to store the LSB of the 16-bit value to be compared to the Up/Down counter content.

MULTIFUNCTION TIMER (Cont'd)

TIMER CONTROL REGISTER (TCR)

R248 - Read/Write

Register Page: 10

Reset value: 0000 0000 (00h)

7							0
GEN	CCP0	CCMP0	CCL	UDC	UDCS	OF0	CS

Bit 7 = **CEN**: *Counter enable*.
 This bit is ANDed with the Global Counter Enable bit (GCEN) in the CICR register (R230). The GCEN bit is set after the Reset cycle.
 0: Stop the counter and prescaler
 1: Start the counter and prescaler (without reload).

Note: Even if CEN=0, capture and loading will take place on a trigger event.

Bit 6 = **CCP0**: *Clear on capture*.
 0: No effect
 1: Clear the counter and reload the prescaler on a REG0R or REG1R capture event

Bit 5 = **CCMP0**: *Clear on Compare*.
 0: No effect
 1: Clear the counter and reload the prescaler on a CMP0R compare event

Bit 4 = **CCL**: *Counter clear*.
 This bit is reset by hardware after being set by software (this bit always returns "0" when read).
 0: No effect
 1: Clear the counter without generating an interrupt request

Bit 3 = **UDC**: *Up/Down software selection*.
 If the direction of the counter is not fixed by hardware (TxINA and/or TxINB pins, see par. 10.3) it can be controlled by software using the UDC bit.
 0: Down counting
 1: Up counting

Bit 2 = **UDCS**: *Up/Down count status*.
 This bit is read only and indicates the direction of the counter.
 0: Down counting
 1: Up counting

Bit 1 = **OF0**: *OVF/UNF state*.
 This bit is read only.
 0: No overflow or underflow occurred
 1: Overflow or underflow occurred during a Capture on Register 0

Bit 0 = **CS** *Counter Status*.
 This bit is read only and indicates the status of the counter.
 0: Counter halted
 1: Counter running

MULTIFUNCTION TIMER (Cont'd)

TIMER MODE REGISTER (TMR)

R249 - Read/Write

Register Page: 10

Reset value: 0000 0000 (00h)

7							0
OE1	OE0	BM	RM1	RM0	ECK	REN	CO

Bit 7 = **OE1**: *Output 1 enable.*

0: Disable the Output 1 (TxOUTB pin) and force it high.

1: Enable the Output 1 (TxOUTB pin)

The relevant I/O bit must also be set to Alternate Function

Bit 6 = **OE0**: *Output 0 enable.*

0: Disable the Output 0 (TxOUTA pin) and force it high

1: Enable the Output 0 (TxOUTA pin).

The relevant I/O bit must also be set to Alternate Function

Bit 5 = **BM**: *Bivalue mode.*

This bit works together with the RM1 and RM0 bits to select the timer operating mode (see [Table 41](#)).

0: Disable bivalue mode

1: Enable bivalue mode

Bit 4 = **RM1**: *REG1R mode.*

This bit works together with the BM and RM0 bits to select the timer operating mode. Refer to [Table 41](#).

Note: This bit has no effect when the Bivalue Mode is enabled (BM=1).

Bit 3 = **RM0**: *REG0R mode.*

This bit works together with the BM and RM1 bits to select the timer operating mode. Refer to [Table 41](#).

Table 41. Timer Operating Modes

TMR Bits			Timer Operating Modes
BM	RM1	RM0	
1	x	0	Biload mode
1	x	1	Bicapture mode
0	0	0	Load from REG0R and Monitor on REG1R
0	1	0	Load from REG0R and Capture on REG1R
0	0	1	Capture on REG0R and Monitor on REG1R
0	1	1	Capture on REG0R and REG1R

Bit 2 = **ECK**: *Timer clock control.*

0: The prescaler clock source is selected depending on the IN0 - IN3 bits in the T_ICR register

1: Enter Parallel mode (for Timer 1 and Timer 3 only, no effect for Timer 0 and 2). See [Section 10.4.2.12](#).

Bit 1 = **REN**: *Retriggerable mode.*

0: Enable retriggerable mode

1: Disable retriggerable mode

Bit 0 = **CO**: *Continuous/One shot mode.*

0: Continuous mode (with autoreload on End of Count condition)

1: One shot mode

MULTIFUNCTION TIMER (Cont'd)

EXTERNAL INPUT CONTROL REGISTER (T_ICR)

R250 - Read/Write

Register Page: 10

Reset value: 0000 0000 (00h)

7							0
IN3	IN2	IN1	IN0	A0	A1	B0	B1

Bits 7:4 = **IN[3:0]**: *Input pin function.*

These bits are set and cleared by software.

IN[3:0] bits	TxINA Pin Function	TxINB Input Pin Function
0000	not used	not used
0001	not used	Trigger
0010	Gate	not used
0011	Gate	Trigger
0100	not used	Ext. Clock
0101	Trigger	not used
0110	Gate	Ext. Clock
0111	Trigger	Trigger
1000	Clock Up	Clock Down
1001	Up/Down	Ext. Clock
1010	Trigger Up	Trigger Down
1011	Up/Down	not used
1100	Autodiscr.	Autodiscr.
1101	Trigger	Ext. Clock
1110	Ext. Clock	Trigger
1111	Trigger	Gate

Bits 3:2 = **A[0:1]**: *TxINA Pin event.*

These bits are set and cleared by software.

A0	A1	TxINA Pin Event
0	0	No operation
0	1	Falling edge sensitive
1	0	Rising edge sensitive
1	1	Rising and falling edges

Bits 1:0 = **B[0:1]**: *TxINB Pin event.*

These bits are set and cleared by software.

B0	B1	TxINB Pin Event
0	0	No operation
0	1	Falling edge sensitive
1	0	Rising edge sensitive
1	1	Rising and falling edges

PRESCALER REGISTER (PRSR)

R251 - Read/Write

Register Page: 10

Reset value: 0000 0000 (00h)

7							0
P7	P6	P5	P4	P3	P2	P1	P0

This register holds the preset value for the 8-bit prescaler. The PRSR content may be modified at any time, but it will be loaded into the prescaler at the following prescaler underflow, or as a consequence of a counter reload (either by software or upon external request).

Following a RESET condition, the prescaler is automatically loaded with 00h, so that the prescaler divides by 1 and the maximum counter clock is generated (Crystal oscillator clock frequency divided by 6 when MODER.5 = DIV2 bit is set).

The binary value programmed in the PRSR register is equal to the divider value minus one. For example, loading PRSR with 24 causes the prescaler to divide by 25.

MULTIFUNCTION TIMER (Cont'd)

OUTPUT A CONTROL REGISTER (OACR)

R252 - Read/Write
 Register Page: 10
 Reset value: 0000 0000

7							0
C0E0	C0E1	C1E0	C1E1	OUE0	OUE1	CEV	OP

Bits 7:6 = **C0E[0:1]**: *COMP0* action bits.
 These bits are set and cleared by software. They configure the action to be performed on the TxOUTA pin when a successful compare of the CMP0R register occurs. Refer to [Table 42](#) for the list of actions that can be configured.

Bits 5:4 = **C1E[0:1]**: *COMP1* action bits.
 These bits are set and cleared by software. They configure the action to be performed on the TxOUTA pin when a successful compare of the CMP1R register occurs. Refer to [Table 42](#) for the list of actions that can be configured.

Bits 3:2 = **OUE[0:1]**: *OVF/UNF* action bits.
 These bits are set and cleared by software. They configure the action to be performed on the TxOUTA pin when an Overflow or Underflow of the U/D counter occurs. Refer to [Table 42](#) for the list of actions that can be configured.

Table 42. Output A Action Bits

xxE0	xxE1	Action on TxOUTA pin when an xx event occurs
0	0	Set
0	1	Toggle
1	0	Reset
1	1	NOP

Notes:

- xx stands for C0, C1 or OU.
- Whenever more than one event occurs simultaneously, Action bit 0 will be the result of ANDing Action bit 0 of all simultaneous events and Action bit 1 will be the result of ANDing Action bit 1 of all simultaneous events.

Bit 1 = **CEV**: *On-Chip event on CMP0R*.

This bit is set and cleared by software.

0: No action

1: A successful compare on CMP0R activates the on-chip event signal (a single pulse is generated)

Bit 0 = **OP**: *TxOUTA preset value*.

This bit is set and cleared by software and by hardware. The value of this bit is the preset value of the TxOUTA pin. Reading this bit returns the current state of the TxOUTA pin (useful when it is selected in toggle mode).

MULTIFUNCTION TIMER (Cont'd)

OUTPUT B CONTROL REGISTER (OBCR)

R253 - Read/Write

Register Page: 10

Reset value: 0000 0000 (00h)

7							0
C0E0	C0E1	C1E0	C1E1	OUE0	OUE1	OEV	OP

Bits 7:6 = **C0E[0:1]**: *COMP0 Action Bits*.
 These bits are set and cleared by software. They configure the type of action to be performed on the TxOUTB output pin when successful compare of the CMP0R register occurs. Refer to [Table 43](#) for the list of actions that can be configured.

Bits 5:4 = **C1E[0:1]**: *COMP1 Action Bits*.
 These bits are set and cleared by software. They configure the type of action to be performed on the TxOUTB output pin when a successful compare of the CMP1R register occurs. Refer to [Table 43](#) for the list of actions that can be configured.

Bits 3:2 = **OUE[0:1]**: *OVF/UNF Action Bits*.
 These bits are set and cleared by software. They configure the type of action to be performed on the TxOUTB output pin when an Overflow or Underflow on the U/D counter occurs. Refer to [Table 43](#) for the list of actions that can be configured.

Table 43. Output B Action Bits

xxE0	xxE1	Action on the TxOUTB pin when an xx event occurs
0	0	Set
0	1	Toggle
1	0	Reset
1	1	NOP

Notes:

- xx stands for C0, C1 or OU.
- Whenever more than one event occurs simultaneously, Action Bit 0 will be the result of ANDing Action Bit 0 of all simultaneous events and Action Bit 1 will be the result of ANDing Action Bit 1 of all simultaneous events.

Bit 1 = **OEV**: *On-Chip event on OVF/UNF*.

This bit is set and cleared by software.

0: No action

1: An underflow/overflow activates the on-chip event signal (a single pulse is generated)

Bit 0 = **OP**: *TxOUTB preset value*.

This bit is set and cleared by software and by hardware. The value of this bit is the preset value of the TxOUTB pin. Reading this bit returns the current state of the TxOUTB pin (useful when it is selected in toggle mode).

MULTIFUNCTION TIMER (Cont'd)

FLAG REGISTER (T_FLAGR)

R254 - Read/Write

Register Page: 10

Reset value: 0000 0000 (00h)

7							0
CP0	CP1	CM0	CM1	OUF	OCP0	OCM0	A0

Bit 7 = **CP0**: Capture 0 flag.

This bit is set by hardware after a capture on REG0R register. An interrupt is generated depending on the value of the GTIEN, CP0I bits in the IDMR register and the A0 bit in the T_FLAGR register. The CP0 bit must be cleared by software. Setting by software acts as a software load/capture to/from the REG0R register.

0: No Capture 0 event

1: Capture 0 event occurred

Bit 6 = **CP1**: Capture 1 flag.

This bit is set by hardware after a capture on REG1R register. An interrupt is generated depending on the value of the GTIEN, CP0I bits in the IDMR register and the A0 bit in the T_FLAGR register. The CP1 bit must be cleared by software. Setting by software acts as a capture event on the REG1R register, except when in Bicapture mode.

0: No Capture 1 event

1: Capture 1 event occurred

Bit 5 = **CM0**: Compare 0 flag.

This bit is set by hardware after a successful compare on the CMP0R register. An interrupt is generated if the GTIEN and CM0I bits in the IDMR register are set. The CM0 bit is cleared by software.

0: No Compare 0 event

1: Compare 0 event occurred

Bit 4 = **CM1**: Compare 1 flag.

This bit is set after a successful compare on CMP1R register. An interrupt is generated if the

GTIEN and CM1I bits in the IDMR register are set. The CM1 bit is cleared by software.

0: No Compare 1 event

1: Compare 1 event occurred

Bit 3 = **OUF**: Overflow/Underflow.

This bit is set by hardware after a counter Over/Underflow condition. An interrupt is generated if GTIEN and OUI=1 in the IDMR register. The OUF bit is cleared by software.

0: No counter overflow/underflow

1: Counter overflow/underflow

Bit 2 = **OCP0**: Overrun on Capture 0.

This bit is set by hardware when more than one INT/DMA requests occur before the CP0 flag is cleared by software or whenever a capture is simulated by setting the CP0 flag by software. The OCP0 flag is cleared by software.

0: No capture 0 overrun

1: Capture 0 overrun

Bit 1 = **OCM0**: Overrun on compare 0.

This bit is set by hardware when more than one INT/DMA requests occur before the CM0 flag is cleared by software. The OCM0 flag is cleared by software.

0: No compare 0 overrun

1: Compare 0 overrun

Bit 0 = **A0**: Capture interrupt function.

This bit is set and cleared by software.

0: Configure the capture interrupt as an OR function of REG0R/REG1R captures

1: Configure the capture interrupt as an AND function of REG0R/REG1R captures

Note: When A0 is set, both CP0I and CP1I in the IDMR register must be set to enable both capture interrupts.

MULTIFUNCTION TIMER (Cont'd)

INTERRUPT/DMA MASK REGISTER (IDMR)

R255 - Read/Write

Register Page: 10

Reset value: 0000 0000 (00h)

7							0
GTIEN	CP0D	CP0I	CP1I	CM0D	CM0I	CM1I	OUI

Bit 7 = **GTIEN**: *Global timer interrupt enable.*
 This bit is set and cleared by software.
 0: Disable all Timer interrupts
 1: Enable all timer Timer Interrupts from enabled sources

Bit 6 = **CP0D**: *Capture 0 DMA mask.*
 This bit is set by software to enable a Capt0 DMA transfer and cleared by hardware at the end of the block transfer.
 0: Disable capture on REG0R DMA
 1: Enable capture on REG0R DMA

Bit 5 = **CP0I**: *Capture 0 interrupt mask.*
 0: Disable capture on REG0R interrupt
 1: Enable capture on REG0R interrupt (or Capt0 DMA End of Block interrupt if CP0D=1)

Bit 4 = **CP1I**: *Capture 1 interrupt mask.*
 This bit is set and cleared by software.
 0: Disable capture on REG1R interrupt
 1: Enable capture on REG1R interrupt

Bit 3 = **CM0D**: *Compare 0 DMA mask.*
 This bit is set by software to enable a Comp0 DMA transfer and cleared by hardware at the end of the block transfer.
 0: Disable compare on CMP0R DMA
 1: Enable compare on CMP0R DMA

Bit 2 = **CM0I**: *Compare 0 Interrupt mask.*
 This bit is set and cleared by software.
 0: Disable compare on CMP0R interrupt
 1: Enable compare on CMP0R interrupt (or Comp0 DMA End of Block interrupt if CM0D=1)

Bit 1 = **CM1I**: *Compare 1 Interrupt mask.*
 This bit is set and cleared by software.
 0: Disable compare on CMP1R interrupt
 1: Enable compare on CMP1R interrupt

Bit 0 = **OUI**: *Overflow/Underflow interrupt mask.*
 This bit is set and cleared by software.
 0: Disable Overflow/Underflow interrupt
 1: Enable Overflow/Underflow interrupt

DMA COUNTER POINTER REGISTER (DCPR)

R240 - Read/Write

Register Page: 9

Reset value: undefined

7							0
DCP7	DCP6	DCP5	DCP4	DCP3	DCP2	DMA SRCE	REG/MEM

Bits 7:2 = **DCP[7:2]**: *MSBs of DMA counter register address.*

These are the most significant bits of the DMA counter register address programmable by software. The DCP2 bit may also be toggled by hardware if the Timer DMA section for the Compare 0 channel is configured in Swap mode.

Bit 1 = **DMA-SRCE**: *DMA source selection.*
 This bit is set and cleared by hardware.
 0: DMA source is a Capture on REG0R register
 1: DMA destination is a Compare on CMP0R register

Bit 0 = **REG/MEM**: *DMA area selection.*
 This bit is set and cleared by software. It selects the source and destination of the DMA area
 0: DMA from/to memory
 1: DMA from/to Register File

MULTIFUNCTION TIMER (MFT)

MULTIFUNCTION TIMER (Cont'd)

DMA ADDRESS POINTER REGISTER (DAPR)

R241 - Read/Write

Register Page: 9

Reset value: undefined

7							0
DAP7	DAP6	DAP5	DAP4	DAP3	DAP2	DMA SRCE	PRG /DAT

Bits 7:2 = **DAP[7:2]**: *MSB of DMA address register location.*

These are the most significant bits of the DMA address register location programmable by software. The DAP2 bit may also be toggled by hardware if the Timer DMA section for the Compare 0 channel is configured in Swap mode.

Note: During a DMA transfer with the Register File, the DAPR is not used; however, in Swap mode, DAP2 is used to point to the correct table.

Bit 1 = **DMA-SRCE**: *DMA source selection.*

This bit is fixed by hardware.

0: DMA source is a Capture on REG0R register

1: DMA destination is a Compare on the CMP0R register

Bit 0 = **PRG/DAT**: *DMA memory selection.*

This bit is set and cleared by software. It is only meaningful if DCPR.REG/MEM=0.

0: The ISR register is used to extend the address of data transferred by DMA (see MMU chapter).

1: The DMASR register is used to extend the address of data transferred by DMA (see MMU chapter).

REG/MEM	PRG/DAT	DMA Source/Destination
0	0	ISR register used to address memory
0	1	DMASR register used to address memory
1	0	Register file
1	1	Register file

INTERRUPT VECTOR REGISTER (T_IVR)

R242 - Read/Write

Register Page: 9

Reset value: xxxx xxx0

7							0
V4	V3	V2	V1	V0	W1	W0	0

This register is used as a vector, pointing to the 16-bit interrupt vectors in memory which contain the starting addresses of the three interrupt sub-routines managed by each timer.

Only one Interrupt Vector Register is available for each timer, and it is able to manage three interrupt groups, because the 3 least significant bits are fixed by hardware depending on the group which generated the interrupt request.

In order to determine which request generated the interrupt within a group, the T_FLAGR register can be used to check the relevant interrupt source.

Bits 7:3 = **V[4:0]**: *MSB of the vector address.*

These bits are user programmable and contain the five most significant bits of the Timer interrupt vector addresses in memory. In any case, an 8-bit address can be used to indicate the Timer interrupt vector locations, because they are within the first 256 memory locations (see Interrupt and DMA chapters).

Bits 2:1 = **W[1:0]**: *Vector address bits.*

These bits are equivalent to bit 1 and bit 2 of the Timer interrupt vector addresses in memory. They are fixed by hardware, depending on the group of sources which generated the interrupt request as follows:.

W1	W0	Interrupt Source
0	0	Overflow/Underflow even interrupt
0	1	Not available
1	0	Capture event interrupt
1	1	Compare event interrupt

Bit 0 = This bit is forced by hardware to 0.

MULTIFUNCTION TIMER (Cont'd)

INTERRUPT/DMA CONTROL REGISTER (IDCR)

R243 - Read/Write

Register Page: 9

Reset value: 1100 0111 (C7h)

7							0
CPE	CME	DCTS	DCTD	SWEN	PL2	PL1	PL0

Bit 7 = **CPE**: *Capture 0 EOB.*

This bit is set by hardware when the End Of Block condition is reached during a Capture 0 DMA operation with the Swap mode enabled. When Swap mode is disabled (SWEN bit = "0"), the CPE bit is forced to 1 by hardware.

0: No end of block condition

1: Capture 0 End of block

Bit 6 = **CME**: *Compare 0 EOB.*

This bit is set by hardware when the End Of Block condition is reached during a Compare 0 DMA operation with the Swap mode enabled. When the Swap mode is disabled (SWEN bit = "0"), the CME bit is forced to 1 by hardware.

0: No end of block condition

1: Compare 0 End of block

Bit 5 = **DCTS**: *DMA capture transfer source.*

This bit is set and cleared by software. It selects the source of the DMA operation related to the channel associated with the Capture 0.

Note: The I/O port source is available only on specific devices.

0: REG0R register

1: I/O port.

Bit 4 = **DCTD**: *DMA compare transfer destination.*

This bit is set and cleared by software. It selects the destination of the DMA operation related to the channel associated with Compare 0.

Note: The I/O port destination is available only on specific devices.

0: CMP0R register

1: I/O port

Bit 3 = **SWEN**: *Swap function enable.*

This bit is set and cleared by software.

0: Disable Swap mode

1: Enable Swap mode for both DMA channels.

Bits 2:0 = **PL[2:0]**: *Interrupt/DMA priority level.*

With these three bits it is possible to select the Interrupt and DMA priority level of each timer, as one of eight levels (see Interrupt/DMA chapter).

I/O CONNECTION REGISTER (IOCR)

R248 - Read/Write

Register Page: 9

Reset value: 1111 1100 (FCh)

7							0
						SC1	SC0

Bits 7:2 = not used.

Bit 1 = **SC1**: *Select connection odd.*

This bit is set and cleared by software. It selects if the TxOUTA and TxINA pins for Timer 1 and Timer 3 are connected on-chip or not.

0: T1OUTA / T1INA and T3OUTA/ T3INA unconnected

1: T1OUTA connected internally to T1INA and T3OUTA connected internally to T3INA

Bit 0 = **SC0**: *Select connection even.*

This bit is set and cleared by software. It selects if the TxOUTA and TxINA pins for Timer 0 and Timer 2 are connected on-chip or not.

0: T0OUTA / T0INA and T2OUTA/ T2INA unconnected

1: T0OUTA connected internally to T0INA and T2OUTA connected internally to T2INA

Note: Timer 1 and 2 are available only on some devices. Refer to the device block diagram and register map.

10.5 MULTIPROTOCOL SERIAL COMMUNICATIONS INTERFACE (SCI-M)

10.5.1 Introduction

The Multiprotocol Serial Communications Interface (SCI-M) offers full-duplex serial data exchange with a wide range of external equipment. The SCI-M offers four operating modes: Asynchronous, Asynchronous with synchronous clock, Serial expansion and Synchronous.

10.5.2 Main Features

- Full duplex synchronous and asynchronous operation.
- Transmit, receive, line status, and device address interrupt generation.
- Integral Baud Rate Generator capable of dividing the input clock by any value from 2 to $2^{16}-1$ (16 bit word) and generating the internal 16X data sampling clock for asynchronous operation or the 1X clock for synchronous operation.
- Fully programmable serial interface:
 - 5, 6, 7, or 8 bit word length.
 - Even, odd, or no parity generation and detection.
 - 0, 1, 1.5, 2, 2.5, 3 stop bit generation.
 - Complete status reporting capabilities.
 - Line break generation and detection.
- Programmable address indication bit (wake-up bit) and user invisible compare logic to support multiple microcomputer networking. Optional character search function.
- Internal diagnostic capabilities:
 - Local loopback for communications link fault isolation.
 - Auto-echo for communications link fault isolation.
- Separate interrupt/DMA channels for transmit and receive.
- In addition, a Synchronous mode supports:
 - High speed communication
 - Possibility of hardware synchronization (RTS/DCD signals).
 - Programmable polarity and stand-by level for data SIN/SOUT.
 - Programmable active edge and stand-by level for clocks CLKOUT/RXCLK.
 - Programmable active levels of RTS/DCD signals.
 - Full Loop-Back and Auto-Echo modes for DATA, CLOCKS and CONTROLS.

Figure 106. SCI-M Block Diagram

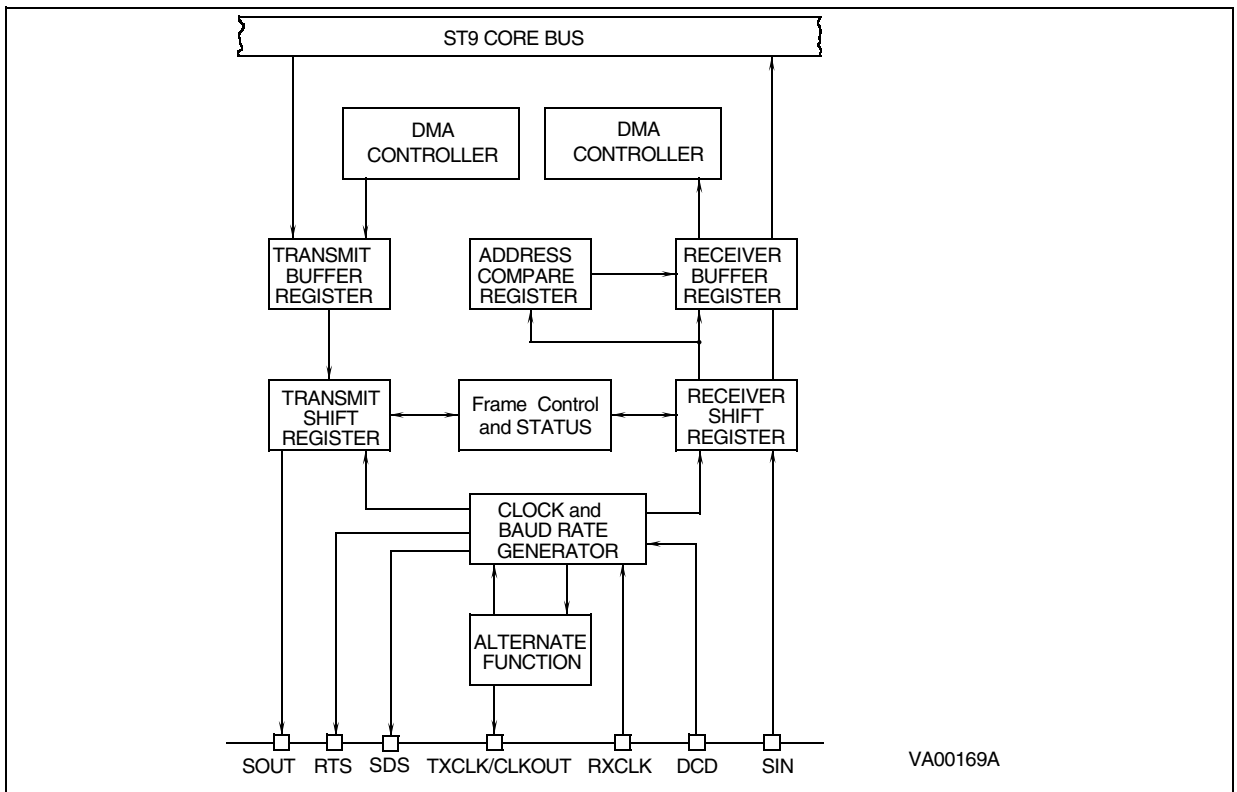

MULTIPROTOCOL SERIAL COMMUNICATIONS INTERFACE (Cont'd)

10.5.3 Functional Description

The SCI-M has four operating modes:

- Asynchronous mode
- Asynchronous mode with synchronous clock
- Serial expansion mode
- Synchronous mode

Asynchronous mode, Asynchronous mode with synchronous clock and Serial expansion mode output data with the same serial frame format. The differences lie in the data sampling clock rates (1X, 16X) and in the protocol used.

Figure 107. SCI -M Functional Schematic

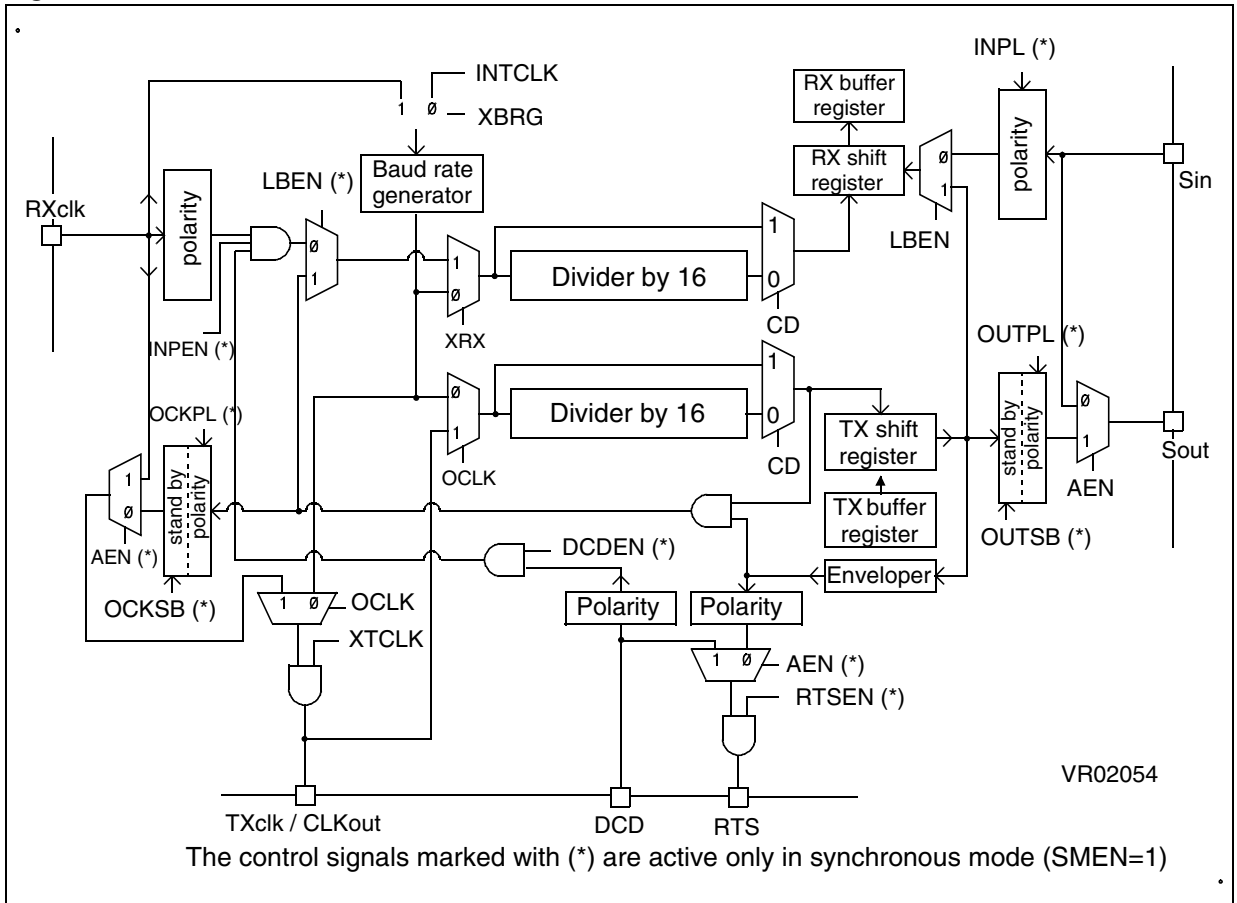

Note: Some pins may not be available on some devices. Refer to the device Pinout Description.

MULTIPROTOCOL SERIAL COMMUNICATIONS INTERFACE (Cont'd)

10.5.4 SCI-M Operating Modes

10.5.4.1 Asynchronous Mode

In this mode, data and clock can be asynchronous (the transmitter and receiver can use their own clocks to sample received data), each data bit is sampled 16 times per clock period.

The baud rate clock should be set to the $\div 16$ Mode and the frequency of the input clock (from an external source or from the internal baud-rate generator output) is set to suit.

10.5.4.2 Asynchronous Mode with Synchronous Clock

In this mode, data and clock are synchronous, each data bit is sampled once per clock period.

For transmit operation, a general purpose I/O port pin can be programmed to output the CLKOUT signal from the baud rate generator. If the SCI is provided with an external transmission clock source, there will be a skew equivalent to two INTCLK periods between clock and data.

Data will be transmitted on the falling edge of the transmit clock. Received data will be latched into the SCI on the rising edge of the receive clock.

Figure 108. Sampling Times in Asynchronous Format

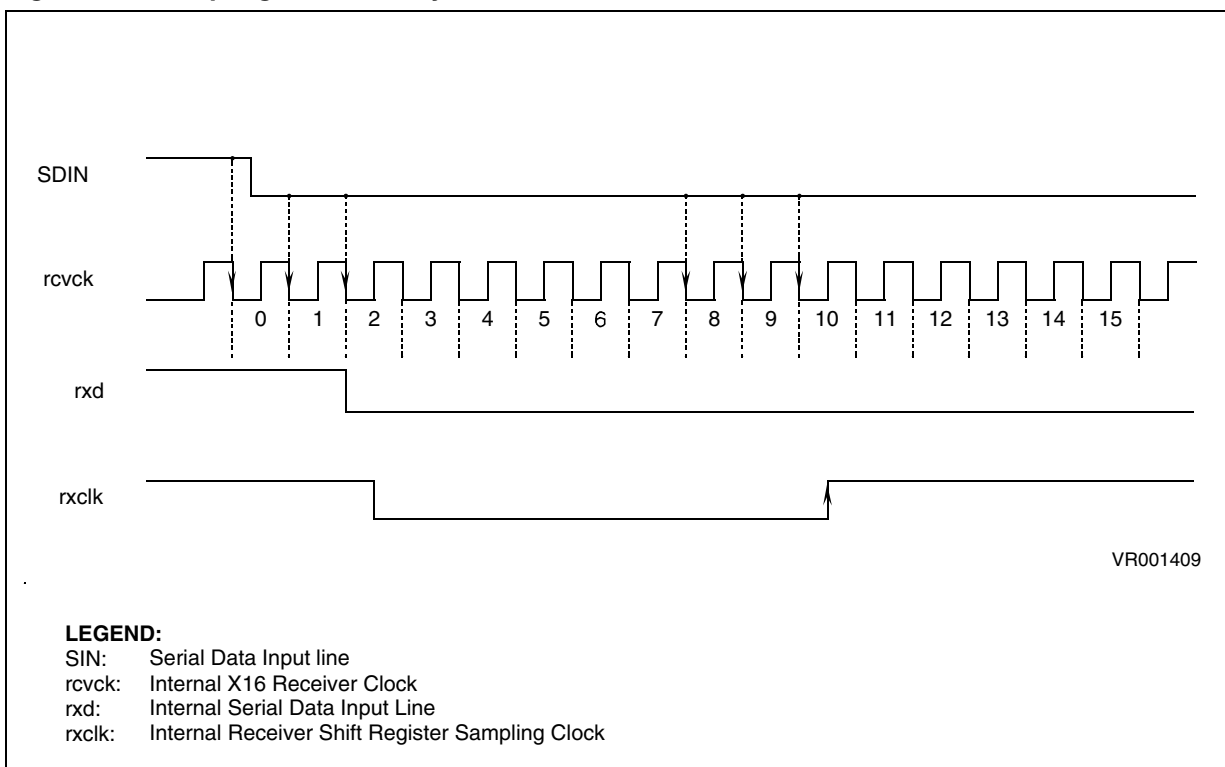

MULTIPROTOCOL SERIAL COMMUNICATIONS INTERFACE (Cont'd)

10.5.4.3 Serial Expansion Mode

This mode is used to communicate with an external synchronous peripheral.

The transmitter only provides the clock waveform during the period that data is being transmitted on the CLKOUT pin (the Data Envelope). Data is latched on the rising edge of this clock.

Whenever the SCI is to receive data in serial port expansion mode, the clock must be supplied externally, and be synchronous with the transmitted data. The SCI latches the incoming data on the rising edge of the received clock, which is input on the RXCLK pin.

10.5.4.4 Synchronous Mode

This mode is used to access an external synchronous peripheral, dummy start/stop bits are not included in the data frame. Polarity, stand-by level and active edges of I/O signals are fully and separately programmable for both inputs and outputs.

It's necessary to set the SMEN bit of the Synchronous Input Control Register (SICR) to enable this mode and all the related extra features (otherwise disabled).

The transmitter will provide the clock waveform only during the period when the data is being transmitted via the CLKOUT pin, which can be enabled by setting both the XTCLK and OCLK bits of

the Clock Configuration Register. Whenever the SCI is to receive data in synchronous mode, the clock waveform must be supplied externally via the RXCLK pin and be synchronous with the data. For correct receiver operation, the XRX bit of the Clock Configuration Register must be set.

Two external signals, Request-To-Send and Data-Carrier-Detect (RTS/DCD), can be enabled to synchronise the data exchange between two serial units. The RTS output becomes active just before the first active edge of CLKOUT and indicates to the target device that the MCU is about to send a synchronous frame; it returns to its stand-by state following the last active edge of CLKOUT (MSB transmitted).

The DCD input can be considered as a gate that filters RXCLK and informs the MCU that a transmitting device is transmitting a data frame. Polarity of RTS/DCD is individually programmable, as for clocks and data.

The data word is programmable from 5 to 8 bits, as for the other modes; parity, address/9th, stop bits and break cannot be inserted into the transmitted frame. Programming of the related bits of the SCI control registers is irrelevant in Synchronous Mode: all the corresponding interrupt requests must, in any case, be masked in order to avoid incorrect operation during data reception.

MULTIPROTOCOL SERIAL COMMUNICATIONS INTERFACE (Cont'd)

Figure 109. SCI -M Operating Modes

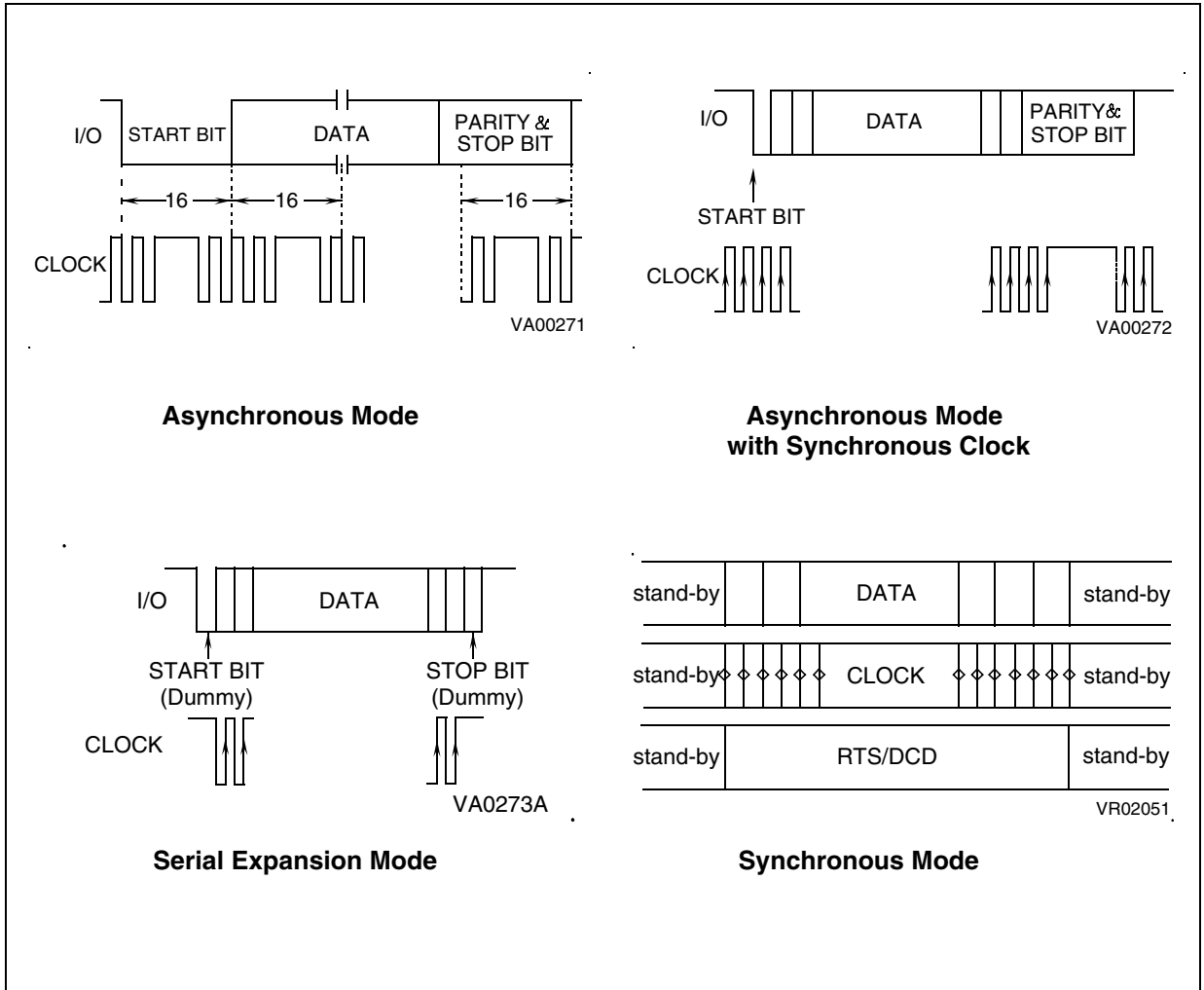

Note: In all operating modes, the Least Significant Bit is transmitted/received first.

MULTIPROTOCOL SERIAL COMMUNICATIONS INTERFACE (Cont'd)

10.5.5 Serial Frame Format

Characters sent or received by the SCI can have some or all of the features in the following format, depending on the operating mode:

START: the START bit indicates the beginning of a data frame in Asynchronous modes. The START condition is detected as a high to low transition. A dummy START bit is generated in Serial Expansion mode. The START bit is not generated in Synchronous mode.

DATA: the DATA word length is programmable from 5 to 8 bits, for both Synchronous and Asynchronous modes. LSB are transmitted first.

PARITY: The Parity Bit (not available in Serial Expansion mode and Synchronous mode) is optional, and can be used with any word length. It is used for error checking and is set so as to make the total number of high bits in DATA plus PARITY odd or even, depending on the number of "1"s in the DATA field.

ADDRESS/9TH: The Address/9th Bit is optional and may be added to any word format. It is used in

both Serial Expansion and Asynchronous modes to indicate that the data is an address (bit set).

The ADDRESS/9TH bit is useful when several microcontrollers are exchanging data on the same serial bus. Individual microcontrollers can stay idle on the serial bus, waiting for a transmitted address. When a microcontroller recognizes its own address, it can begin Data Reception, likewise, on the transmit side, the microcontroller can transmit another address to begin communication with a different microcontroller.

The ADDRESS/9TH bit can be used as an additional data bit or to mark control words (9th bit).

STOP: Indicates the end of a data frame in Asynchronous modes. A dummy STOP bit is generated in Serial Expansion mode. The STOP bit can be programmed to be 1, 1.5, 2, 2.5 or 3 bits long, depending on the mode. It returns the SCI to the quiescent marking state (i.e., a constant high-state condition) which lasts until a new start bit indicates an incoming word. The STOP bit is not generated in Synchronous mode.

Figure 110. SCI Character Formats

	START ⁽²⁾	DATA ⁽¹⁾	PARITY ⁽³⁾	ADDRESS ⁽²⁾	STOP ⁽²⁾	
# bits	1	5, 6, 7, 8	0, 1	0, 1	1, 1.5, 2, 2.5, 1, 2, 3	16X 1X
states			NONE ODD EVEN	ON OFF		

(1) LSB First

(2) Not available in Synchronous mode

(3) Not available in Serial Expansion mode and Synchronous mode

MULTIPROTOCOL SERIAL COMMUNICATIONS INTERFACE (Cont'd)

10.5.5.1 Data transfer

Data to be transmitted by the SCI is first loaded by the program into the Transmitter Buffer Register. The SCI will transfer the data into the Transmitter Shift Register when the Shift Register becomes available (empty). The Transmitter Shift Register converts the parallel data into serial format for transmission via the SCI Alternate Function output, Serial Data Out. On completion of the transfer, the transmitter buffer register interrupt pending bit will be updated. If the selected word length is less than 8 bits, the unused most significant bits do not need to be defined.

Incoming serial data from the Serial Data Input pin is converted into parallel format by the Receiver Shift Register. At the end of the input data frame, the valid data portion of the received word is transferred from the Receiver Shift Register into the Receiver Buffer Register. All Receiver interrupt conditions are updated at the time of transfer. If the selected character format is less than 8 bits, the unused most significant bits will be set.

The Frame Control and Status block creates and checks the character configuration (Data length and number of Stop bits), as well as the source of the transmitter/receiver clock.

The internal Baud Rate Generator contains a programmable divide by “N” counter which can be used to generate the clocks for the transmitter and/or receiver. The baud rate generator can use INTCLK or the Receiver clock input via RXCLK.

The Address bit/D9 is optional and may be added to any word in Asynchronous and Serial Expansion modes. It is commonly used in network or machine control applications. When enabled (AB set), an address or ninth data bit can be added to a transmitted word by setting the Set Address bit (SA). This is then appended to the next word entered into the (empty) Transmitter Buffer Register and then cleared by hardware. On character input, a set Address Bit can indicate that the data preceding the bit is an address which may be compared in hardware with the value in the Address Compare Register (ACR) to generate an Address Match interrupt when equal.

The Address bit and Address Comparison Register can also be combined to generate four different types of Address Interrupt to suit different protocols, based on the status of the Address Mode Enable bit (AMEN) and the Address Mode bit (AM) in the CHCR register.

The character match Address Interrupt mode may be used as a powerful character search mode, generating an interrupt on reception of a predetermined character e.g. Carriage Return or End of Block codes (Character Match Interrupt). This is the only Address Interrupt Mode available in Synchronous mode.

The Line Break condition is fully supported for both transmission and reception. Line Break is sent by setting the SB bit (IDPR). This causes the transmitter output to be held low (after all buffered data has been transmitted) for a minimum of one complete word length and until the SB bit is Reset. Break cannot be inserted into the transmitted frame for the Synchronous mode.

Testing of the communications channel may be performed using the built-in facilities of the SCI peripheral. Auto-Echo mode and Loop-Back mode may be used individually or together. In Asynchronous, Asynchronous with Synchronous Clock and Serial Expansion modes they are available only on SIN/SOUT pins through the programming of AEN/LBEN bits in CCR. In Synchronous mode (SMEN set) the above configurations are available on SIN/SOUT, RXCLK/CLKOUT and DCD/RTS pins by programming the AEN/LBEN bits and independently of the programmed polarity. In the Synchronous mode case, when AEN is set, the transmitter outputs (data, clock and control) are disconnected from the I/O pins, which are driven directly by the receiver input pins (Auto-Echo mode: SOUT=SIN, CLKOUT=RXCLK and RTS=DCD, even if they act on the internal receiver with the programmed polarity/edge). When LBEN is set, the receiver inputs (data, clock and controls) are disconnected and the transmitter outputs are looped-back into the receiver section (Loop-Back mode: SIN=SOUT, RXCLK=CLKOUT, DCD=RTS). The output pins are locked to their programmed stand-by level and the status of the INPL, XCKPL, DCDPL, OUTPL, OCKPL and RTSPL bits in the SICR register are irrelevant). Refer to [Figure 111](#), [Figure 112](#), and [Figure 113](#) for these different configurations.

Table 44. Address Interrupt Modes

If 9th Data Bit is set ⁽¹⁾
If Character Match
If Character Match and 9th Data Bit is set ⁽¹⁾
If Character Match Immediately Follows BREAK ⁽¹⁾

⁽¹⁾ Not available in Synchronous mode

MULTIPROTOCOL SERIAL COMMUNICATIONS INTERFACE (Cont'd)

Figure 111. Auto Echo Configuration

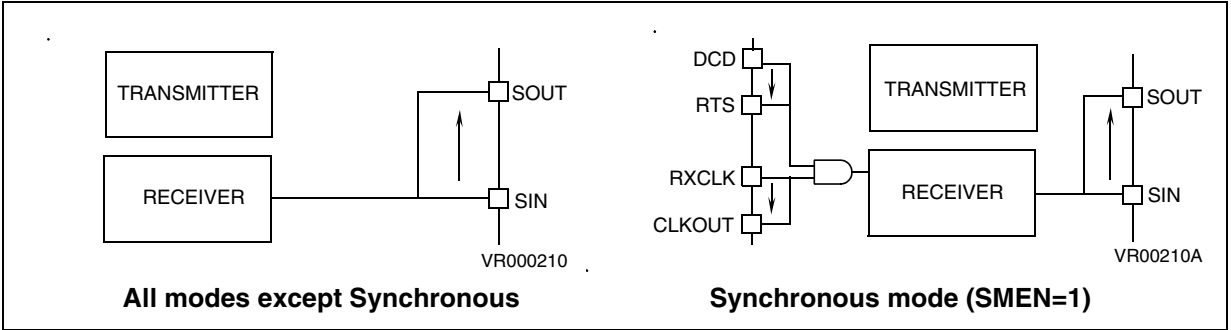

Figure 112. Loop Back Configuration

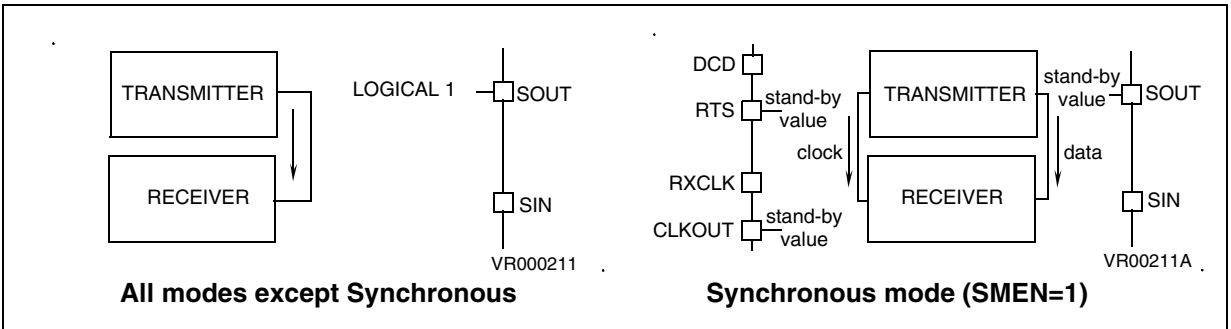
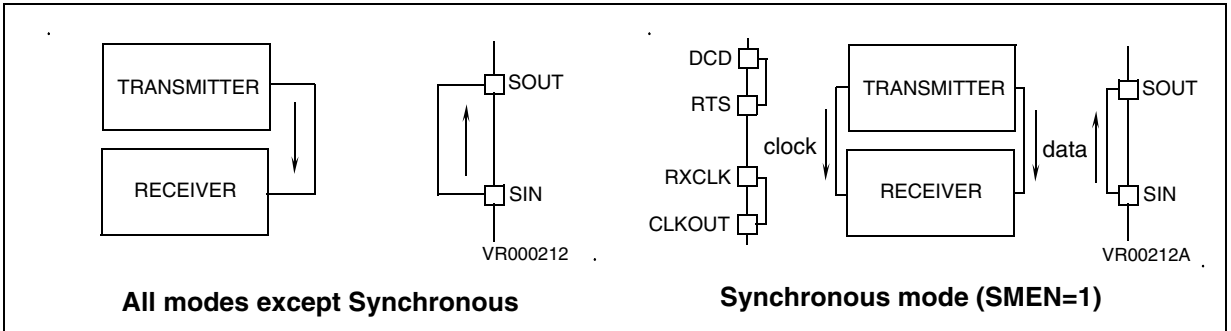

Figure 113. Auto Echo and Loop-Back Configuration



MULTIPROTOCOL SERIAL COMMUNICATIONS INTERFACE (Cont'd)

10.5.6 Clocks And Serial Transmission Rates

The communication bit rate of the SCI transmitter and receiver sections can be provided from the internal Baud Rate Generator or from external sources. The bit rate clock is divided by 16 in Asynchronous mode (CD in CCR reset), or undivided in the 3 other modes (CD set).

With INTCLK running at 24MHz and no external Clock provided, a maximum bit rate of 3MBaud and 750KBaud is available in undivided and divide by-16-mode respectively.

With INTCLK running at 24MHz and an external Clock provided through the RXCLK/TXCLK lines, a maximum bit rate of 3MBaud and 375KBaud is available in undivided and divided by 16 mode respectively (see [Figure 115](#)).

External Clock Sources. The External Clock input pin TXCLK may be programmed by the XTCLK and OCLK bits in the CCR register as: the transmit clock input, Baud Rate Generator output (allowing an external divider circuit to provide the receive clock for split rate transmit and receive), or as CLKOUT output in Synchronous and Serial Expansion modes. The RXCLK Receive clock input is enabled by the XRX bit, this input should be set in accordance with the setting of the CD bit.

Baud Rate Generator. The internal Baud Rate Generator consists of a 16-bit programmable divide by "N" counter which can be used to generate the transmitter and/or receiver clocks. The minimum baud rate divisor is 2 and the maximum divisor is $2^{16}-1$. After initialising the baud rate generator, the divisor value is immediately loaded into the counter. This prevents potentially long random counts on the initial load.

The Baud Rate generator frequency is equal to the Input Clock frequency divided by the Divisor value.

WARNING: Programming the baud rate divider to 0 or 1 will stop the divider.

The output of the Baud Rate generator has a precise 50% duty cycle. The Baud Rate generator can use INTCLK for the input clock source. In this case, INTCLK (and therefore the MCU Xtal) should be chosen to provide a suitable frequency for division by the Baud Rate Generator to give the required transmit and receive bit rates. Suitable INTCLK frequencies and the respective divider values for standard Baud rates are shown in [Table 45](#).

10.5.7 SCI -M Initialization Procedure

Writing to either of the two Baud Rate Generator Registers immediately disables and resets the SCI baud rate generator, as well as the transmitter and receiver circuitry.

After writing to the second Baud Rate Generator Register, the transmitter and receiver circuits are enabled. The Baud Rate Generator will load the new value and start counting.

To initialize the SCI, the user should first initialize the most significant byte of the Baud Rate Generator Register; this will reset all SCI circuitry. The user should then initialize all other SCI registers (SICR/SOCR included) for the desired operating mode and then, to enable the SCI, he should initialize the least significant byte Baud Rate Generator Register.

'On-the-Fly' modifications of the control registers' content during transmitter/receiver operations, although possible, can corrupt data and produce undesirable spikes on the I/O lines (data, clock and control). Furthermore, modifying the control registers' content without reinitialising the SCI circuitry (during stand-by cycles, waiting to transmit or receive data) must be kept carefully under control by software to avoid spurious data being transmitted or received.

Note: For synchronous receive operation, the data and receive clock must not exhibit significant skew between clock and data. The received data and clock are internally synchronized to INTCLK.

Figure 114. SCI-M Baud Rate Generator Initialization Sequence

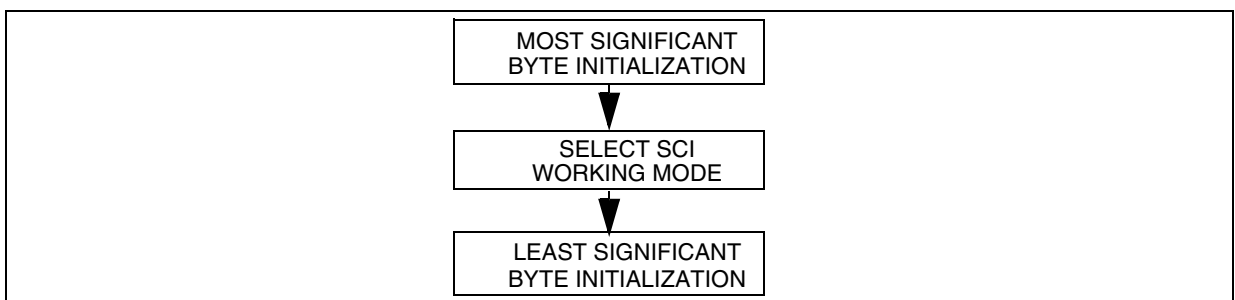

MULTIPROTOCOL SERIAL COMMUNICATIONS INTERFACE (Cont'd)

Table 45. SCI-M Baud Rate Generator Divider Values Example 1

INTCLK: 19660.800 KHz							
Baud Rate	Clock Factor	Desired Freq (kHz)	Divisor		Actual Baud Rate	Actual Freq (kHz)	Deviation
			Dec	Hex			
50.00	16 X	0.80000	24576	6000	50.00	0.80000	0.0000%
75.00	16 X	1.20000	16384	4000	75.00	1.20000	0.0000%
110.00	16 X	1.76000	11170	2BA2	110.01	1.76014	-0.00081%
300.00	16 X	4.80000	4096	1000	300.00	4.80000	0.0000%
600.00	16 X	9.60000	2048	800	600.00	9.60000	0.0000%
1200.00	16 X	19.20000	1024	400	1200.00	19.20000	0.0000%
2400.00	16 X	38.40000	512	200	2400.00	38.40000	0.0000%
4800.00	16 X	76.80000	256	100	4800.00	76.80000	0.0000%
9600.00	16 X	153.60000	128	80	9600.00	153.60000	0.0000%
19200.00	16 X	307.20000	64	40	19200.00	307.20000	0.0000%
38400.00	16 X	614.40000	32	20	38400.00	614.40000	0.0000%
76800.00	16 X	1228.80000	16	10	76800.00	1228.80000	0.0000%

Table 46. SCI-M Baud Rate Generator Divider Values Example 2

INTCLK: 24576 KHz							
Baud Rate	Clock Factor	Desired Freq (kHz)	Divisor		Actual Baud Rate	Actual Freq (kHz)	Deviation
			Dec	Hex			
50.00	16 X	0.80000	30720	7800	50.00	0.80000	0.0000%
75.00	16 X	1.20000	20480	5000	75.00	1.20000	0.0000%
110.00	16 X	1.76000	13963	383B	110.01	1.76014	-0.00046%
300.00	16 X	4.80000	5120	1400	300.00	4.80000	0.0000%
600.00	16 X	9.60000	2560	A00	600.00	9.60000	0.0000%
1200.00	16 X	19.20000	1280	500	1200.00	19.20000	0.0000%
2400.00	16 X	38.40000	640	280	2400.00	38.40000	0.0000%
4800.00	16 X	76.80000	320	140	4800.00	76.80000	0.0000%
9600.00	16 X	153.60000	160	A0	9600.00	153.60000	0.0000%
19200.00	16 X	307.20000	80	50	19200.00	307.20000	0.0000%
38400.00	16 X	614.40000	40	28	38400.00	614.40000	0.0000%
76800.00	16 X	1228.80000	20	14	76800.00	1228.80000	0.0000%

MULTIPROTOCOL SERIAL COMMUNICATIONS INTERFACE (Cont'd)

10.5.8 Input Signals

SIN: Serial Data Input. This pin is the serial data input to the SCI receiver shift register.

TXCLK: External Transmitter Clock Input. This pin is the external input clock driving the SCI transmitter. The TXCLK frequency must be greater than or equal to 16 times the transmitter data rate (depending whether the X16 or the X1 clock have been selected). A 50% duty cycle is required for this input and must have a period of at least twice INTCLK. The use of the TXCLK pin is optional.

RXCLK: External Receiver Clock Input. This input is the clock to the SCI receiver when using an external clock source connected to the baud rate generator. INTCLK is normally the clock source. A 50% duty cycle is required for this input and must have a period of at least twice INTCLK. Use of RXCLK is optional.

DCD: Data Carrier Detect. This input is enabled only in Synchronous mode; it works as a gate for the RXCLK clock and informs the MCU that an emitting device is transmitting a synchronous frame. The active level can be programmed as 1 or 0 and must be provided at least one INTCLK period before the first active edge of the input clock.

10.5.9 Output Signals

SOUT: Serial Data Output. This Alternate Function output signal is the serial data output for the SCI transmitter in all operating modes.

CLKOUT: Clock Output. The alternate Function of this pin outputs either the data clock from the transmitter in Serial Expansion or Synchronous modes, or the clock output from the Baud Rate Generator. In Serial expansion mode it will clock

only the data portion of the frame and its stand-by state is high: data is valid on the rising edge of the clock. Even in Synchronous mode CLKOUT will only clock the data portion of the frame, but the stand-by level and active edge polarity are programmable by the user.

When Synchronous mode is disabled (SMEN in SICR is reset), the state of the XTCLK and OCLK bits in CCR determine the source of CLKOUT; '11' enables the Serial Expansion Mode.

When the Synchronous mode is enabled (SMEN in SICR is set), the state of the XTCLK and OCLK bits in CCR determine the source of CLKOUT; '00' disables it for PLM applications.

RTS: Request To Send. This output Alternate Function is only enabled in Synchronous mode; it becomes active when the Least Significant Bit of the data frame is sent to the Serial Output Pin (SOUT) and indicates to the target device that the MCU is about to send a synchronous frame; it returns to its stand-by value just after the last active edge of CLKOUT (MSB transmitted). The active level can be programmed high or low.

SDS: Synchronous Data Strobe. This output Alternate function is only enabled in Synchronous mode; it becomes active high when the Least Significant Bit is sent to the Serial Output Pins (SOUT) and indicates to the target device that the MCU is about to send the first bit for each synchronous frame. It is active high on the first bit and it is low for all the rest of the frame. The active level can not be programmed.

Figure 115. Receiver and Transmitter Clock Frequencies

		Min	Max	Conditions
Receiver Clock Frequency	External RXCLK	0	INTCLK/8	1x mode
		0	INTCLK/4	16x mode
	Internal Receiver Clock	0	INTCLK/8	1x mode
		0	INTCLK/2	16x mode
Transmitter Clock Frequency	External TXCLK	0	INTCLK/8	1x mode
		0	INTCLK/4	16x mode
	Internal Transmitter Clock	0	INTCLK/8	1x mode
		0	INTCLK/2	16x mode

Note: The internal receiver and transmitter clocks are the ones applied to the Tx and Rx shift registers (see [Figure 106](#)).

MULTIPROTOCOL SERIAL COMMUNICATIONS INTERFACE (Cont'd)

10.5.10 Interrupts and DMA

10.5.10.1 Interrupts

The SCI can generate interrupts as a result of several conditions. Receiver interrupts include data pending, receive errors (overrun, framing and parity), as well as address or break pending. Transmitter interrupts are software selectable for either Transmit Buffer Register Empty (BSN set) or for Transmit Shift Register Empty (BSN reset) conditions.

Typical usage of the Interrupts generated by the SCI peripheral are illustrated in [Figure 116](#).

The SCI peripheral is able to generate interrupt requests as a result of a number of events, several of which share the same interrupt vector. It is therefore necessary to poll S_ISR, the Interrupt Status Register, in order to determine the active

trigger. These bits should be reset by the programmer during the Interrupt Service routine.

The four major levels of interrupt are encoded in hardware to provide two bits of the interrupt vector register, allowing the position of the block of pointer vectors to be resolved to an 8 byte block size.

The SCI interrupts have an internal priority structure in order to resolve simultaneous events. Refer also to Section 10.5.4 SCI-M Operating Modes for more details relating to Synchronous mode.

Table 47. SCI Interrupt Internal Priority

Receive DMA Request	Highest Priority
Transmit DMA Request	
Receive Interrupt	Lowest Priority
Transmit Interrupt	

MULTIPROTOCOL SERIAL COMMUNICATIONS INTERFACE (Cont'd)

Table 48. SCI-M Interrupt Vectors

Interrupt Source	Vector Address
Transmitter Buffer or Shift Register Empty Transmit DMA end of Block	xxx x110
Received Data Pending Receive DMA end of Block	xxxx x100
Break Detector Address Word Match	xxxx x010
Receiver Error	xxxx x000

Figure 116. SCI-M Interrupts: Example of Typical Usage

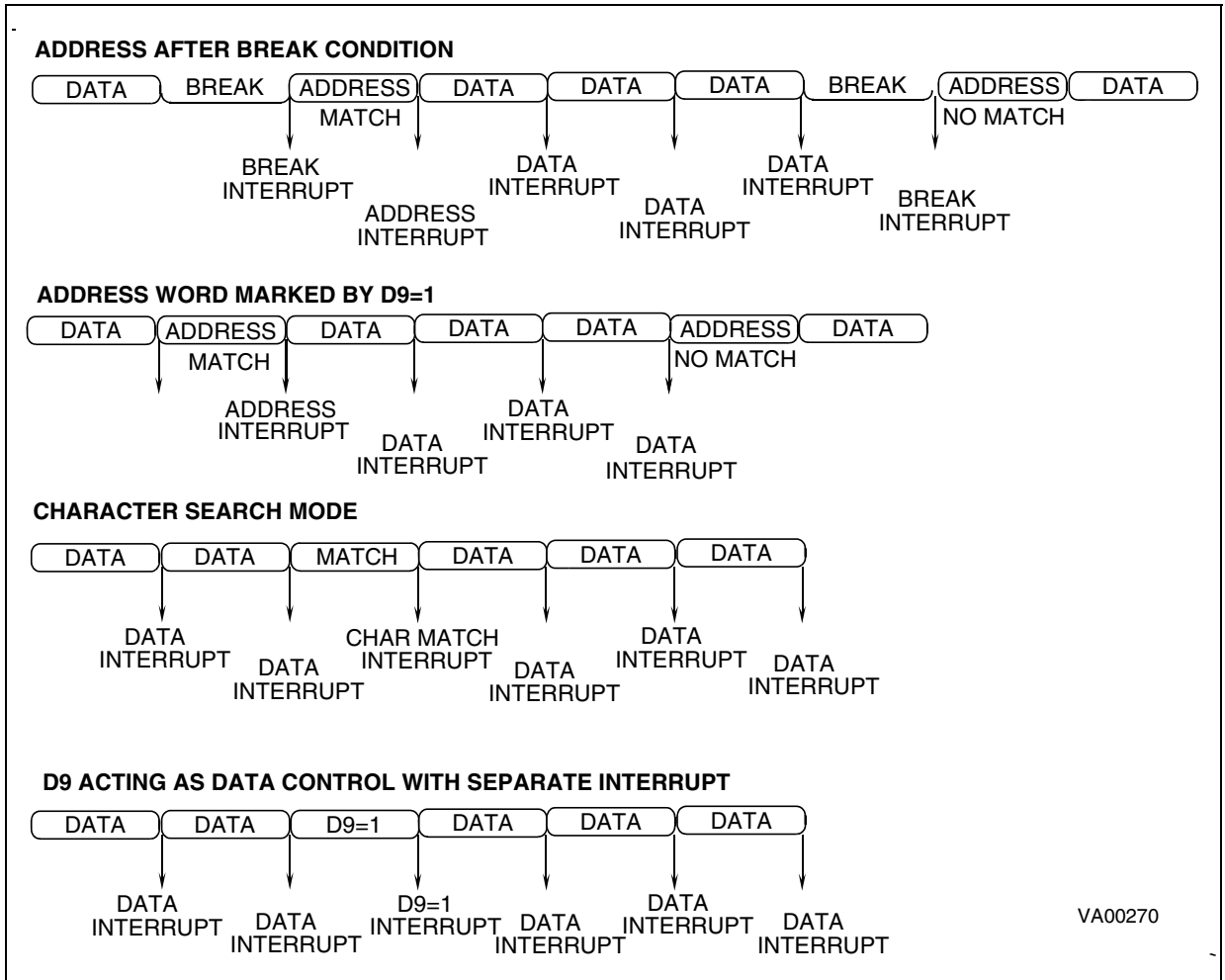

MULTIPROTOCOL SERIAL COMMUNICATIONS INTERFACE (Cont'd)

10.5.10.2 DMA

Two DMA channels are associated with the SCI, for transmit and for receive. These follow the register scheme as described in the DMA chapter.

DMA Reception

To perform a DMA transfer in reception mode:

1. Initialize the DMA counter (RDCPR) and DMA address (RDAPR) registers
2. Enable DMA by setting the RXD bit in the IDPR register.
3. DMA transfer is started when data is received by the SCI.

DMA Transmission

To perform a DMA transfer in transmission mode:

1. Initialize the DMA counter (TDCPR) and DMA address (TDAPR) registers.
2. Enable DMA by setting the TXD bit in the IDPR register.
3. DMA transfer is started by writing a byte in the Transmitter Buffer register (TXBR).

If this byte is the first data byte to be transmitted, the DMA counter and address registers must be initialized to begin DMA transmission at the second byte. Alternatively, DMA transfer can be started by writing a dummy byte in the TXBR register.

DMA Interrupts

When DMA is active, the Received Data Pending and the Transmitter Shift Register Empty interrupt sources are replaced by the DMA End Of Block receive and transmit interrupt sources.

Note: To handle DMA transfer correctly in transmission, the BSN bit in the IMR register must be cleared. This selects the Transmitter Shift Register Empty event as the DMA interrupt source.

The transfer of the last byte of a DMA data block will be followed by a DMA End Of Block transmit or receive interrupt, setting the TXEOB or RXEOB bit.

A typical Transmission End Of Block interrupt routine will perform the following actions:

1. Restore the DMA counter register (TDCPR).
2. Restore the DMA address register (TDAPR).
3. Clear the Transmitter Shift Register Empty bit TXSEM in the S_ISR register to avoid spurious interrupts.
4. Clear the Transmitter End Of Block (TXEOB) pending bit in the IMR register.
5. Set the TXD bit in the IDPR register to enable DMA.
6. Load the Transmitter Buffer Register (TXBR) with the next byte to transmit.

The above procedure handles the case where a further DMA transfer is to be performed.

Error Interrupt Handling

If an error interrupt occurs while DMA is enabled in reception mode, DMA transfer is stopped.

To resume DMA transfer, the error interrupt handling routine must clear the corresponding error flag. In the case of an Overrun error, the routine must also read the RXBR register.

Character Search Mode with DMA

In Character Search Mode with DMA, when a character match occurs, this character is not transferred. DMA continues with the next received character. To avoid an Overrun error occurring, the Character Match interrupt service routine must read the RXBR register.

MULTIPROTOCOL SERIAL COMMUNICATIONS INTERFACE (Cont'd)

10.5.11 Register Description

The SCI-M registers are located in the following pages in the ST9:

SCI-M number 0: page 24 (18h)

SCI-M number 1: page 25 (19h) (when present)

The SCI is controlled by the following registers:

Address	Register
R240 (F0h)	Receiver DMA Transaction Counter Pointer Register
R241 (F1h)	Receiver DMA Source Address Pointer Register
R242 (F2h)	Transmitter DMA Transaction Counter Pointer Register
R243 (F3h)	Transmitter DMA Destination Address Pointer Register
R244 (F4h)	Interrupt Vector Register
R245 (F5h)	Address Compare Register
R246 (F6h)	Interrupt Mask Register
R247 (F7h)	Interrupt Status Register
R248 (F8h)	Receive Buffer Register same Address as Transmitter Buffer Register (Read Only)
R248 (F8h)	Transmitter Buffer Register same Address as Receive Buffer Register (Write only)
R249 (F9h)	Interrupt/DMA Priority Register
R250 (FAh)	Character Configuration Register
R251 (FBh)	Clock Configuration Register
R252 (FCh)	Baud Rate Generator High Register
R253 (FDh)	Baud Rate Generator Low Register
R254 (FEh)	Synchronous Input Control Register
R255 (FFh)	Synchronous Output Control Register

MULTIPROTOCOL SERIAL COMMUNICATIONS INTERFACE (Cont'd)

RECEIVER DMA COUNTER POINTER (RDCPR)

R240 - Read/Write

Reset value: undefined

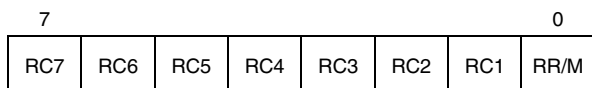

Bit 7:1 = **RC[7:1]**: *Receiver DMA Counter Pointer*. These bits contain the address of the receiver DMA transaction counter in the Register File.

Bit 0 = **RR/M**: *Receiver Register File/Memory Selector*.

- 0: Select Memory space as destination.
- 1: Select the Register File as destination.

RECEIVER DMA ADDRESS POINTER (RDAPR)

R241 - Read/Write

Reset value: undefined

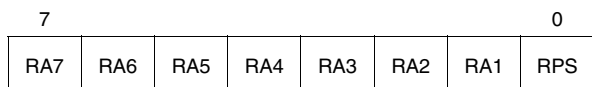

Bit 7:1 = **RA[7:1]**: *Receiver DMA Address Pointer*. These bits contain the address of the pointer (in the Register File) of the receiver DMA data source.

Bit 0 = **RPS**: *Receiver DMA Memory Pointer Selector*.

- This bit is only significant if memory has been selected for DMA transfers (RR/M = 0 in the RDCPR register).
- 0: Select ISR register for receiver DMA transfers address extension.
 - 1: Select DMASR register for receiver DMA transfers address extension.

TRANSMITTER DMA COUNTER POINTER (TDCPR)

R242 - Read/Write

Reset value: undefined

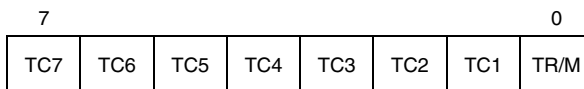

Bit 7:1 = **TC[7:1]**: *Transmitter DMA Counter Pointer*.

These bits contain the address of the transmitter DMA transaction counter in the Register File.

Bit 0 = **TR/M**: *Transmitter Register File/Memory Selector*.

- 0: Select Memory space as source.
- 1: Select the Register File as source.

TRANSMITTER DMA ADDRESS POINTER (TDAPR)

R243 - Read/Write

Reset value: undefined

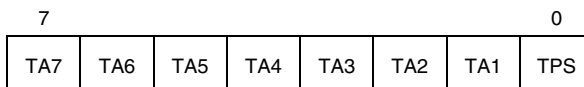

Bit 7:1 = **TA[7:1]**: *Transmitter DMA Address Pointer*.

These bits contain the address of the pointer (in the Register File) of the transmitter DMA data source.

Bit 0 = **TPS**: *Transmitter DMA Memory Pointer Selector*.

- This bit is only significant if memory has been selected for DMA transfers (TR/M = 0 in the TDCPR register).
- 0: Select ISR register for transmitter DMA transfers address extension.
 - 1: Select DMASR register for transmitter DMA transfers address extension.

MULTIPROTOCOL SERIAL COMMUNICATIONS INTERFACE (Cont'd)

INTERRUPT VECTOR REGISTER (S_IVR)

R244 - Read/Write

Reset value: undefined

7							0
V7	V6	V5	V4	V3	EV2	EV1	0

Bit 7:3 = **V[7:3]**: *SCI Interrupt Vector Base Address*.

User programmable interrupt vector bits for transmitter and receiver.

Bit 2:1 = **EV[2:1]**: *Encoded Interrupt Source*.

Both bits EV2 and EV1 are read only and set by hardware according to the interrupt source.

EV2	EV1	Interrupt source
0	0	Receiver Error (Overrun, Framing, Parity)
0	1	Break Detect or Address Match
1	0	Received Data Pending/Receiver DMA End of Block
1	1	Transmitter buffer or shift register empty transmitter DMA End of Block

Bit 0 = **D0**: This bit is forced by hardware to 0.

ADDRESS/DATA COMPARE REGISTER (ACR)

R245 - Read/Write

Reset value: undefined

7							0
AC7	AC6	AC5	AC4	AC3	AC2	AC1	AC0

Bit 7:0 = **AC[7:0]**: *Address/Compare Character*. With either 9th bit address mode, address after break mode, or character search, the received address will be compared to the value stored in this register. When a valid address matches this register content, the Receiver Address Pending bit (RXAP in the S_ISR register) is set. After the RXAP bit is set in an addressed mode, all received data words will be transferred to the Receiver Buffer Register.

MULTIPROTOCOL SERIAL COMMUNICATIONS INTERFACE (Cont'd)

INTERRUPT MASK REGISTER (IMR)

R246 - Read/Write

Reset value: 0xx00000

7							0
BSN	RXEOB	TXEOB	RXE	RXA	RXB	RXDI	TXDI

Bit 7 = **BSN**: *Buffer or shift register empty interrupt*.

This bit selects the source of the transmitter register empty interrupt.

0: Select a Shift Register Empty as source of a Transmitter Register Empty interrupt.

1: Select a Buffer Register Empty as source of a Transmitter Register Empty interrupt.

Bit 6 = **RXEOB**: *Received End of Block*.

This bit is set by hardware only and must be reset by software. RXEOB is set after a receiver DMA cycle to mark the end of a data block.

0: Clear the interrupt request.

1: Mark the end of a received block of data.

Bit 5 = **TXEOB**: *Transmitter End of Block*.

This bit is set by hardware only and must be reset by software. TXEOB is set after a transmitter DMA cycle to mark the end of a data block.

0: Clear the interrupt request.

1: Mark the end of a transmitted block of data.

Bit 4 = **RXE**: *Receiver Error Mask*.

0: Disable Receiver error interrupts (OE, PE, and FE pending bits in the S_ISR register).

1: Enable Receiver error interrupts.

Bit 3 = **RXA**: *Receiver Address Mask*.

0: Disable Receiver Address interrupt (RXAP pending bit in the S_ISR register).

1: Enable Receiver Address interrupt.

Bit 2 = **RXB**: *Receiver Break Mask*.

0: Disable Receiver Break interrupt (RXBP pending bit in the S_ISR register).

1: Enable Receiver Break interrupt.

Bit 1 = **RXDI**: *Receiver Data Interrupt Mask*.

0: Disable Receiver Data Pending and Receiver End of Block interrupts (RXDP and RXEOB pending bits in the S_ISR register).

1: Enable Receiver Data Pending and Receiver End of Block interrupts.

Note: RXDI has no effect on DMA transfers.

Bit 0 = **TXDI**: *Transmitter Data Interrupt Mask*.

0: Disable Transmitter Buffer Register Empty, Transmitter Shift Register Empty, or Transmitter End of Block interrupts (TXBEM, TXSEM, and TXEOB bits in the S_ISR register).

1: Enable Transmitter Buffer Register Empty, Transmitter Shift Register Empty, or Transmitter End of Block interrupts.

Note: TXDI has no effect on DMA transfers.

MULTIPROTOCOL SERIAL COMMUNICATIONS INTERFACE (Cont'd)

INTERRUPT STATUS REGISTER (S_ISR)

R247 - Read/Write

Reset value: undefined

7							0
OE	FE	PE	RXAP	RXBP	RXDP	TXBEM	TXSEM

Bit 7 = **OE**: *Overrun Error Pending.*

This bit is set by hardware if the data in the Receiver Buffer Register was not read by the CPU before the next character was transferred into the Receiver Buffer Register (the previous data is lost).

0: No Overrun Error.

1: Overrun Error occurred.

Bit 6 = **FE**: *Framing Error Pending bit.*

This bit is set by hardware if the received data word did not have a valid stop bit.

0: No Framing Error.

1: Framing Error occurred.

Note: In the case where a framing error occurs when the SCI is programmed in address mode and is monitoring an address, the interrupt is asserted and the corrupted data element is transferred to the Receiver Buffer Register.

Bit 5 = **PE**: *Parity Error Pending.*

This bit is set by hardware if the received word did not have the correct even or odd parity bit.

0: No Parity Error.

1: Parity Error occurred.

Bit 4 = **RXAP**: *Receiver Address Pending.*

RXAP is set by hardware after an interrupt acknowledged in the address mode.

0: No interrupt in address mode.

1: Interrupt in address mode occurred.

Note: The source of this interrupt is given by the couple of bits (AMEN, AM) as detailed in the IDPR register description.

Bit 3 = **RXBP**: *Receiver Break Pending bit.*

This bit is set by hardware if the received data input is held low for the full word transmission time (start bit, data bits, parity bit, stop bit).

0: No break received.

1: Break event occurred.

Bit 2 = **RXDP**: *Receiver Data Pending bit.*

This bit is set by hardware when data is loaded into the Receiver Buffer Register.

0: No data received.

1: Data received in Receiver Buffer Register.

Bit 1 = **TXBEM**: *Transmitter Buffer Register Empty.*

This bit is set by hardware if the Buffer Register is empty.

0: No Buffer Register Empty event.

1: Buffer Register Empty.

Bit 0 = **TXSEM**: *Transmitter Shift Register Empty.*

This bit is set by hardware if the Shift Register has completed the transmission of the available data.

0: No Shift Register Empty event.

1: Shift Register Empty.

Note: The Interrupt Status Register bits can be reset but cannot be set by the user. The interrupt source must be cleared by resetting the related bit when executing the interrupt service routine (naturally the other pending bits should not be reset).

MULTIPROTOCOL SERIAL COMMUNICATIONS INTERFACE (Cont'd)

RECEIVER BUFFER REGISTER (RXBR)

R248 - Read only

Reset value: undefined

7							0
RD7	RD6	RD5	RD4	RD3	RD2	RD1	RD0

Bit 7:0 = **RD[7:0]**: *Received Data*.

This register stores the data portion of the received word. The data will be transferred from the Receiver Shift Register into the Receiver Buffer Register at the end of the word. All receiver interrupt conditions will be updated at the time of transfer. If the selected character format is less than 8 bits, unused most significant bits will forced to "1".

Note: RXBR and TXBR are two physically different registers located at the same address.

TRANSMITTER BUFFER REGISTER (TXBR)

R248 - Write only

Reset value: undefined

7							0
TD7	TD6	TD5	TD4	TD3	TD2	TD1	TD0

Bit 7:0 = **TD[7:0]**: *Transmit Data*.

The ST9 core will load the data for transmission into this register. The SCI will transfer the data from the buffer into the Shift Register when available. At the transfer, the Transmitter Buffer Register interrupt is updated. If the selected word format is less than 8 bits, the unused most significant bits are not significant.

Note: TXBR and RXBR are two physically different registers located at the same address.

MULTIPROTOCOL SERIAL COMMUNICATIONS INTERFACE (Cont'd)

INTERRUPT/DMA PRIORITY REGISTER (IDPR)

R249 - Read/Write

Reset value: undefined

7							0
AMEN	SB	SA	RXD	TXD	PRL2	PRL1	PRL0

Bit 7 = **AMEN**: *Address Mode Enable*.

This bit, together with the AM bit (in the CHCR register), decodes the desired addressing/9th data bit/character match operation.

In Address mode the SCI monitors the input serial data until its address is detected

AMEN	AM	
0	0	Address interrupt if 9th data bit = 1
0	1	Address interrupt if character match
1	0	Address interrupt if character match and 9th data bit =1
1	1	Address interrupt if character match with word immediately following Break

Note: Upon reception of address, the RXAP bit (in the Interrupt Status Register) is set and an interrupt cycle can begin. The address character will not be transferred into the Receiver Buffer Register but all data following the matched SCI address and preceding the next address word will be transferred to the Receiver Buffer Register and the proper interrupts updated. If the address does not match, all data following this unmatched address will not be transferred to the Receiver Buffer Register.

In any of the cases the RXAP bit must be reset by software before the next word is transferred into the Buffer Register.

When AMEN is reset and AM is set, a useful character search function is performed. This allows the SCI to generate an interrupt whenever a specific character is encountered (e.g. Carriage Return).

Bit 6 = **SB**: *Set Break*.

0: Stop the break transmission after minimum break length.

1: Transmit a break following the transmission of all data in the Transmitter Shift Register and the Buffer Register.

Note: The break will be a low level on the transmitter data output for at least one complete word for-

mat. If software does not reset SB before the minimum break length has finished, the break condition will continue until software resets SB. The SCI terminates the break condition with a high level on the transmitter data output for one transmission clock period.

Bit 5 = **SA**: *Set Address*.

If an address/9th data bit mode is selected, SA value will be loaded for transmission into the Shift Register. This bit is cleared by hardware after its load.

0: Indicate it is not an address word.

1: Indicate an address word.

Note: Proper procedure would be, when the Transmitter Buffer Register is empty, to load the value of SA and then load the data into the Transmitter Buffer Register.

Bit 4 = **RXD**: *Receiver DMA Mask*.

This bit is reset by hardware when the transaction counter value decrements to zero. At that time a receiver End of Block interrupt can occur.

0: Disable Receiver DMA request (the RXDP bit in the S_ISR register can request an interrupt).

1: Enable Receiver DMA request (the RXDP bit in the S_ISR register can request a DMA transfer).

Bit 3 = **TXD**: *Transmitter DMA Mask*.

This bit is reset by hardware when the transaction counter value decrements to zero. At that time a transmitter End Of Block interrupt can occur.

0: Disable Transmitter DMA request (TXBEM or TXSEM bits in S_ISR can request an interrupt).

1: Enable Transmitter DMA request (TXBEM or TXSEM bits in S_ISR can request a DMA transfer).

Bit 2:0 = **PRL[2:0]**: *SCI Interrupt/DMA Priority bits*.

The priority for the SCI is encoded with (PRL2,PRL1,PRL0). Priority level 0 is the highest, while level 7 represents no priority.

When the user has defined a priority level for the SCI, priorities within the SCI are hardware defined. These SCI internal priorities are:

Receiver DMA request	highest priority
Transmitter DMA request	
Receiver interrupt	
Transmitter interrupt	lowest priority

MULTIPROTOCOL SERIAL COMMUNICATIONS INTERFACE (Cont'd)

CHARACTER CONFIGURATION REGISTER (CHCR)

R250 - Read/Write

Reset value: undefined

7							0
AM	EP	PEN	AB	SB1	SB0	WL1	WL0

Bit 7 = **AM**: *Address Mode*.

This bit, together with the AMEN bit (in the IDPR register), decodes the desired addressing/9th data bit/character match operation. Please refer to the table in the IDPR register description.

Bit 6 = **EP**: *Even Parity*.

0: Select odd parity (when parity is enabled).
 1: Select even parity (when parity is enabled).

Bit 5 = **PEN**: *Parity Enable*.

0: No parity bit.
 1: Parity bit generated (transmit data) or checked (received data).

Note: If the address/9th bit is enabled, the parity bit will precede the address/9th bit (the 9th bit is never included in the parity calculation).

Bit 4 = **AB**: *Address/9th Bit*.

0: No Address/9th bit.
 1: Address/9th bit included in the character format between the parity bit and the first stop bit. This bit can be used to address the SCI or as a ninth data bit.

Bit 3:2 = **SB[1:0]**: *Number of Stop Bits..*

SB1	SB0	Number of stop bits	
		in 16X mode	in 1X mode
0	0	1	1
0	1	1.5	2
1	0	2	2
1	1	2.5	3

Bit 1:0 = **WL[1:0]**: *Number of Data Bits*

WL1	WL0	Data Length
0	0	5 bits
0	1	6 bits
1	0	7 bits
1	1	8 bits

MULTIPROTOCOL SERIAL COMMUNICATIONS INTERFACE (Cont'd)

CLOCK CONFIGURATION REGISTER (CCR)

R251 - Read/Write

Reset value: 0000 0000 (00h)

7							0
XTCLK	OCLK	XRX	XBRG	CD	AEN	LBEN	STPEN

Bit 7 = XTCLK

This bit, together with the OCLK bit, selects the source for the transmitter clock. The following table shows the coding of XTCLK and OCLK.

Bit 6 = OCLK

This bit, together with the XTCLK bit, selects the source for the transmitter clock. The following table shows the coding of XTCLK and OCLK.

XTCLK	OCLK	Pin Function
0	0	Pin is used as a general I/O
0	1	Pin = TXCLK (used as an input)
1	0	Pin = CLKOUT (outputs the Baud Rate Generator clock)
1	1	Pin = CLKOUT (outputs the Serial expansion and synchronous mode clock)

Bit 5 = XRX: External Receiver Clock Source.

0: External receiver clock source not used.
1: Select the external receiver clock source.

Note: The external receiver clock frequency must be 16 times the data rate, or equal to the data rate, depending on the status of the CD bit.

Bit 4 = XBRG: Baud Rate Generator Clock Source.

0: Select INTCLK for the baud rate generator.
1: Select the external receiver clock for the baud rate generator.

Bit 3 = CD: Clock Divisor.

The status of CD will determine the SCI configuration (synchronous/asynchronous).

0: Select 16X clock mode for both receiver and transmitter.

1: Select 1X clock mode for both receiver and transmitter.

Note: In 1X clock mode, the transmitter will transmit data at one data bit per clock period. In 16X mode each data bit period will be 16 clock periods long.

Bit 2 = AEN: Auto Echo Enable.

0: No auto echo mode.

1: Put the SCI in auto echo mode.

Note: Auto Echo mode has the following effect: the SCI transmitter is disconnected from the data-out pin SOUT, which is driven directly by the receiver data-in pin, SIN. The receiver remains connected to SIN and is operational, unless loopback mode is also selected.

Bit 1 = LBEN: Loopback Enable.

0: No loopback mode.

1: Put the SCI in loopback mode.

Note: In this mode, the transmitter output is set to a high level, the receiver input is disconnected, and the output of the Transmitter Shift Register is looped back into the Receiver Shift Register input. All interrupt sources (transmitter and receiver) are operational.

Bit 0 = STPEN: Stick Parity Enable.

0: The transmitter and the receiver will follow the parity of even parity bit EP in the CHCR register.

1: The transmitter and the receiver will use the opposite parity type selected by the even parity bit EP in the CHCR register.

EP	SPEN	Parity (Transmitter & Receiver)
0 (odd)	0	Odd
1 (even)	0	Even
0 (odd)	1	Even
1 (even)	1	Odd

MULTIPROTOCOL SERIAL COMMUNICATIONS INTERFACE (Cont'd)

BAUD RATE GENERATOR HIGH REGISTER (BRGHR)

R252 - Read/Write

Reset value: undefined

15								8
BG15	BG14	BG13	BG12	BG11	BG10	BG9	BG8	

BAUD RATE GENERATOR LOW REGISTER (BRGLR)

R253 - Read/Write

Reset value: undefined

7								0
BG7	BG6	BG5	BG4	BG3	BG2	BG1	BG0	

Bit 15:0 = *Baud Rate Generator MSB and LSB.*

The Baud Rate generator is a programmable divide by “N” counter which can be used to generate the clocks for the transmitter and/or receiver. This counter divides the clock input by the value in the Baud Rate Generator Register. The minimum baud rate divisor is 2 and the maximum divisor is 2¹⁶-1. After initialization of the baud rate generator, the divisor value is immediately loaded into the counter. This prevents potentially long random counts on the initial load. If set to 0 or 1, the Baud Rate Generator is stopped.

SYNCHRONOUS INPUT CONTROL (SICR)

R254 - Read/Write

Reset value: 0000 0011 (03h)

7							0
SMEN	INPL	XCKPL	DCDEN	DCDPL	INPEN	X	X

Bit 7 = **SMEN**: *Synchronous Mode Enable.*

0: Disable all features relating to Synchronous mode (the contents of SICR and SOCR are ignored).

1: Select Synchronous mode with its programmed I/O configuration.

Bit 6 = **INPL**: *SIN Input Polarity.*

0: Polarity not inverted.

1: Polarity inverted.

Note: INPL only affects received data. In Auto-Echo mode SOUT = SIN even if INPL is set. In Loop-Back mode the state of the INPL bit is irrelevant.

Bit 5 = **XCKPL**: *Receiver Clock Polarity.*

0: RXCLK is active on the rising edge.

1: RXCLK is active on the falling edge.

Note: XCKPL only affects the receiver clock. In Auto-Echo mode CLKOUT = RXCLK independently of the XCKPL status. In Loop-Back the state of the XCKPL bit is irrelevant.

Bit 4 = **DCDEN**: *DCD Input Enable.*

0: Disable hardware synchronization.

1: Enable hardware synchronization.

Note: When DCDEN is set, RXCLK drives the receiver section only during the active level of the DCD input (DCD works as a gate on RXCLK, informing the MCU that a transmitting device is sending a synchronous frame to it).

Bit 3 = **DCDPL**: *DCD Input Polarity.*

0: The DCD input is active when LOW.

1: The DCD input is active when HIGH.

Note: DCDPL only affects the gating activity of the receiver clock. In Auto-Echo mode RTS = DCD independently of DCDPL. In Loop-Back mode, the state of DCDPL is irrelevant.

Bit 2 = **INPEN**: *All Input Disable.*

0: Enable SIN/RXCLK/DCD inputs.

1: Disable SIN/RXCLK/DCD inputs.

Bit 1:0 = “Don't Care”

MULTIPROTOCOL SERIAL COMMUNICATIONS INTERFACE (Cont'd)

SYNCHRONOUS OUTPUT CONTROL (SOCR)

R255 - Read/Write

Reset value: 0000 0001 (01h)

7							0
OUTP L	OUTS B	OCKP L	OCKS B	RTSE N	RTS PL	OUT DIS	X

Bit 7 = **OUTPL**: *SOUT Output Polarity.*

0: Polarity not inverted.

1: Polarity inverted.

Note: OUTPL only affects the data sent by the transmitter section. In Auto-Echo mode SOUT = SIN even if OUTPL=1. In Loop-Back mode, the state of OUTPL is irrelevant.

Bit 6 = **OUTSB**: *SOUT Output Stand-By Level.*

0: SOUT stand-by level is HIGH.

1: SOUT stand-by level is LOW.

Bit 5 = **OCKPL**: *Transmitter Clock Polarity.*

0: CLKOUT is active on the rising edge.

1: CLKOUT is active on the falling edge.

Note: OCKPL only affects the transmitter clock. In Auto-Echo mode CLKOUT = RXCLK independently of the state of OCKPL. In Loop-Back mode the state of OCKPL is irrelevant.

Bit 4 = **OCKSB**: *Transmitter Clock Stand-By Level.*

0: The CLKOUT stand-by level is HIGH.

1: The CLKOUT stand-by level is LOW.

Bit 3 = **RTSEN**: *RTS and SDS Output Enable.*

0: Disable the RTS and SDS hardware synchronisation.

1: Enable the RTS and SDS hardware synchronisation.

Notes:

– When RTSEN is set, the RTS output becomes active just before the first active edge of CLK-OUT and indicates to target device that the MCU is about to send a synchronous frame; it returns to its stand-by value just after the last active edge of CLKOUT (MSB transmitted).

– When RTSEN is set, the SDS output becomes active high and indicates to the target device that the MCU is about to send the first bit of a synchronous frame on the Serial Output Pin (SOUT); it returns to low level as soon as the second bit is sent on the Serial Output Pin (SOUT). In this way a positive pulse is generated each time that the first bit of a synchronous frame is present on the Serial Output Pin (SOUT).

Bit 2 = **RTSPL**: *RTS Output Polarity.*

0: The RTS output is active when LOW.

1: The RTS output is active when HIGH.

Note: RTSPL only affects the RTS activity on the output pin. In Auto-Echo mode RTS = DCD independently from the RTSPL value. In Loop-Back mode RTSPL value is 'Don't Care'.

Bit 1 = **OUTDIS**: *Disable all outputs.*

This feature is available on specific devices only (see device pin-out description).

When OUTDIS=1, all output pins (if configured in Alternate Function mode) will be put in High Impedance for networking.

0: SOUT/CLKOUT/enabled

1: SOUT/CLKOUT/RTS put in high impedance

Bit 0 = "Don't Care"

10.6 ASYNCHRONOUS SERIAL COMMUNICATIONS INTERFACE (SCI-A)

10.6.1 Introduction

The Asynchronous Serial Communications Interface (SCI-A) offers a flexible means of full-duplex data exchange with external equipment requiring an industry standard NRZ asynchronous serial data format. The SCI-A offers a very wide range of baud rates using two baud rate generator systems.

10.6.2 Main Features

- Full duplex, asynchronous communications
- NRZ standard format (Mark/Space)
- Dual baud rate generator systems
- Independently programmable transmit and receive baud rates up to 700K baud.
- Programmable data word length (8 or 9 bits)
- Receive buffer full, Transmit buffer empty and End of Transmission flags
- Two receiver wake-up modes:
 - Address bit (MSB)
 - Idle line
- Muting function for multiprocessor configurations
- Separate enable bits for Transmitter and Receiver
- Three error detection flags:
 - Overrun error
 - Noise error
 - Frame error
- Five interrupt sources with flags:
 - Transmit data register empty
 - Transmission complete
 - Receive data register full
 - Idle line received
 - Overrun error detected
- Parity control:
 - Transmits parity bit
 - Checks parity of received data byte
- Reduced power consumption mode
- LIN Master: 13-bit LIN Synch Break generation capability

10.6.3 General Description

The interface is externally connected to another device by two pins (see [Figure 118](#)):

- TDO: Transmit Data Output. When the transmitter is disabled, the output pin is in high impedance. When the transmitter is enabled and nothing is to be transmitted, the TDO pin is at high level.
- RDI: Receive Data Input is the serial data input. Oversampling techniques are used for data recovery by discriminating between valid incoming data and noise.

Through these pins, serial data is transmitted and received as frames comprising:

- An Idle Line prior to transmission or reception
- A start bit
- A data word (8 or 9 bits) least significant bit first
- A Stop bit indicating that the frame is complete.

This interface uses two types of baud rate generators:

- A conventional type for commonly-used baud rates,
- An extended type with a prescaler offering a very wide range of baud rates even with non-standard oscillator frequencies.

ASYNCHRONOUS SERIAL COMMUNICATIONS INTERFACE (Cont'd)

Figure 117. SCI-A Block Diagram

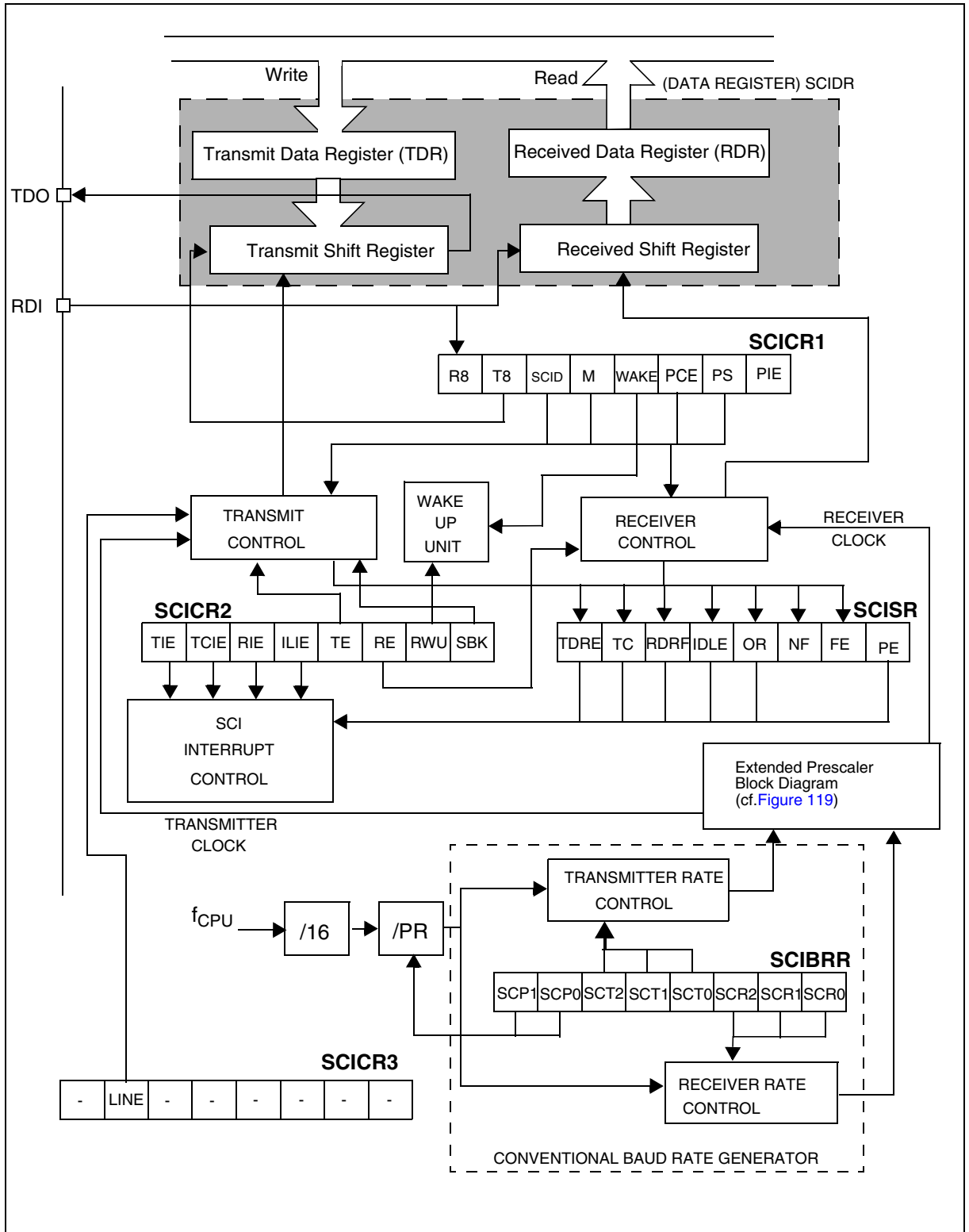

ASYNCHRONOUS SERIAL COMMUNICATIONS INTERFACE (Cont'd)

10.6.4 Functional Description

The block diagram of the Serial Control Interface, is shown in [Figure 117](#). It contains 6 dedicated registers:

- Two control registers (SCICR1 & SCICR2)
- A status register (SCISR)
- A baud rate register (SCIBRR)
- An extended prescaler receiver register (SCIERR)
- An extended prescaler transmitter register (SCIETPR)

Refer to the register descriptions in [Section 10.6.5](#) for the definitions of each bit.

10.6.4.1 Serial Data Format

Word length may be selected as being either 8 or 9 bits by programming the M bit in the SCICR1 register (see [Figure 117](#)).

The TDO pin is in low state during the start bit.

The TDO pin is in high state during the stop bit.

An Idle character is interpreted as an entire frame of “1”s followed by the start bit of the next frame which contains data.

A Break character is interpreted on receiving “0”s for some multiple of the frame period. At the end of the last break frame the transmitter inserts an extra “1” bit to acknowledge the start bit.

Transmission and reception are driven by their own baud rate generator.

Figure 118. Word Length Programming

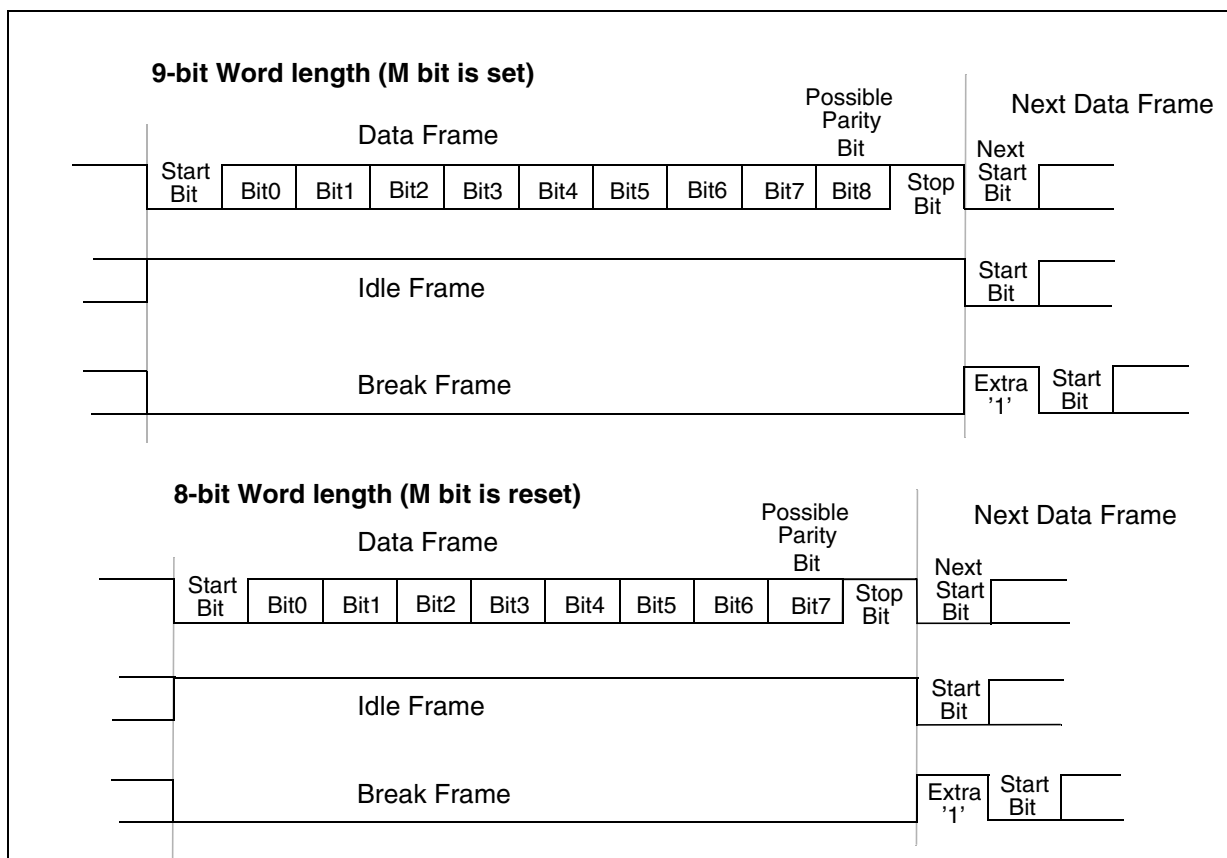

ASYNCHRONOUS SERIAL COMMUNICATIONS INTERFACE (Cont'd)

10.6.4.2 Transmitter

The transmitter can send data words of either 8 or 9 bits depending on the M bit status. When the M bit is set, word length is 9 bits and the 9th bit (the MSB) has to be stored in the T8 bit in the SCICR1 register.

Character Transmission

During an SCI transmission, data shifts out least significant bit first on the TDO pin. In this mode, the SCIDR register consists of a buffer (TDR) between the internal bus and the transmit shift register (see [Figure 117](#)).

Procedure

- Select the M bit to define the word length.
- Select the desired baud rate using the SCIBRR and the SCIETPR registers.
- Set the TE bit to send an idle frame as first transmission.
- Access the SCISR register and write the data to send in the SCIDR register (this sequence clears the TDRE bit). Repeat this sequence for each data to be transmitted.

Clearing the TDRE bit is always performed by the following software sequence:

1. An access to the SCISR register
2. A write to the SCIDR register

The TDRE bit is set by hardware and it indicates:

- The TDR register is empty.
- The data transfer is beginning.
- The next data can be written in the SCIDR register without overwriting the previous data.

This flag generates an interrupt if the TIE bit is set in the SCICR2 register and the IMIO bit is set in the SIMRH register.

When a transmission is taking place, a write instruction to the SCIDR register stores the data in the TDR register and which is copied in the shift register at the end of the current transmission.

When no transmission is taking place, a write instruction to the SCIDR register places the data directly in the shift register, the data transmission starts, and the TDRE bit is immediately set.

When a frame transmission is complete (after the stop bit or after the break frame) the TC bit is set and an interrupt is generated if the TCIE is set and the IMIO bit is set in the SIMRH register.

Clearing the TC bit is performed by the following software sequence:

1. An access to the SCISR register
2. A write to the SCIDR register

Note: The TDRE and TC bits are cleared by the same software sequence.

LIN Transmission

The same procedure has to be applied with the following differences:

- Clear the M bit to configure 8-bit word length
- Set the LINE bit to enter LIN Master mode. In this case, setting the SBK bit will send 13 low bits.

Break Characters

Setting the SBK bit loads the shift register with a break character. The break frame length depends on the M bit (see [Figure 118](#)).

As long as the SBK bit is set, the SCI sends break frames to the TDO pin. After clearing this bit by software, the SCI inserts a logic 1 bit at the end of the last break frame to guarantee the recognition of the start bit of the next frame.

Idle Characters

Setting the TE bit drives the SCI to send an idle frame before the first data frame.

Clearing and then setting the TE bit during a transmission sends an idle frame after the current word.

Note: Resetting and setting the TE bit causes the data in the TDR register to be lost. Therefore the best time to toggle the TE bit is when the TDRE bit is set, i.e. before writing the next byte in the SCIDR.

ASYNCHRONOUS SERIAL COMMUNICATIONS INTERFACE (Cont'd)

10.6.4.3 Receiver

The SCI can receive data words of either 8 or 9 bits. When the M bit is set, word length is 9 bits and the MSB is stored in the R8 bit in the SCICR1 register.

Character Reception

During a SCI reception, data shifts in least significant bit first through the RDI pin. In this mode, the SCIDR register consists of a buffer (RDR) between the internal bus and the received shift register (see [Figure 117](#)).

Procedure

- Select the M bit to define the word length.
- Select the desired baud rate using the SCIBRR and the SCIERPR registers.
- Set the RE bit, this enables the receiver which begins searching for a start bit.

When a character is received:

- The RDRF bit is set. It indicates that the content of the shift register is transferred to the RDR.
- An interrupt is generated if the RIE bit is set and the IMIO bit is set in the SIMRH register.
- The error flags can be set if a frame error, noise or an overrun error has been detected during reception.

Clearing the RDRF bit is performed by the following software sequence done by:

1. An access to the SCISR register
2. A read to the SCIDR register.

The RDRF bit must be cleared before the end of the reception of the next character to avoid an overrun error.

Break Character

When a break character is received, the SCI handles it as a framing error.

Idle Character

When an idle frame is detected, there is the same procedure as a data received character plus an interrupt if the ILIE bit is set and the IMIO bit is set in the SIMRH register.

Overrun Error

An overrun error occurs when a character is received when RDRF has not been reset. Data can not be transferred from the shift register to the TDR register as long as the RDRF bit is not cleared.

When an overrun error occurs:

- The OR bit is set.
- The RDR content will not be lost.
- The shift register will be overwritten.
- An interrupt is generated if the RIE bit is set and the IMIO bit is set in the SIMRH register.

The OR bit is reset by an access to the SCISR register followed by a SCIDR register read operation.

Noise Error

Oversampling techniques are used for data recovery by discriminating between valid incoming data and noise.

When noise is detected in a frame:

- The NF is set at the rising edge of the RDRF bit.
- Data is transferred from the Shift register to the SCIDR register.
- No interrupt is generated. However this bit rises at the same time as the RDRF bit which itself generates an interrupt.

The NF bit is reset by a SCISR register read operation followed by a SCIDR register read operation.

Framing Error

A framing error is detected when:

- The stop bit is not recognized on reception at the expected time, following either a de-synchronization or excessive noise.
- A break is received.

When the framing error is detected:

- the FE bit is set by hardware
- Data is transferred from the Shift register to the SCIDR register.
- No interrupt is generated. However this bit rises at the same time as the RDRF bit which itself generates an interrupt.

The FE bit is reset by a SCISR register read operation followed by a SCIDR register read operation.

ASYNCHRONOUS SERIAL COMMUNICATIONS INTERFACE (Cont'd)

Figure 119. SCI Baud Rate and Extended Prescaler Block Diagram

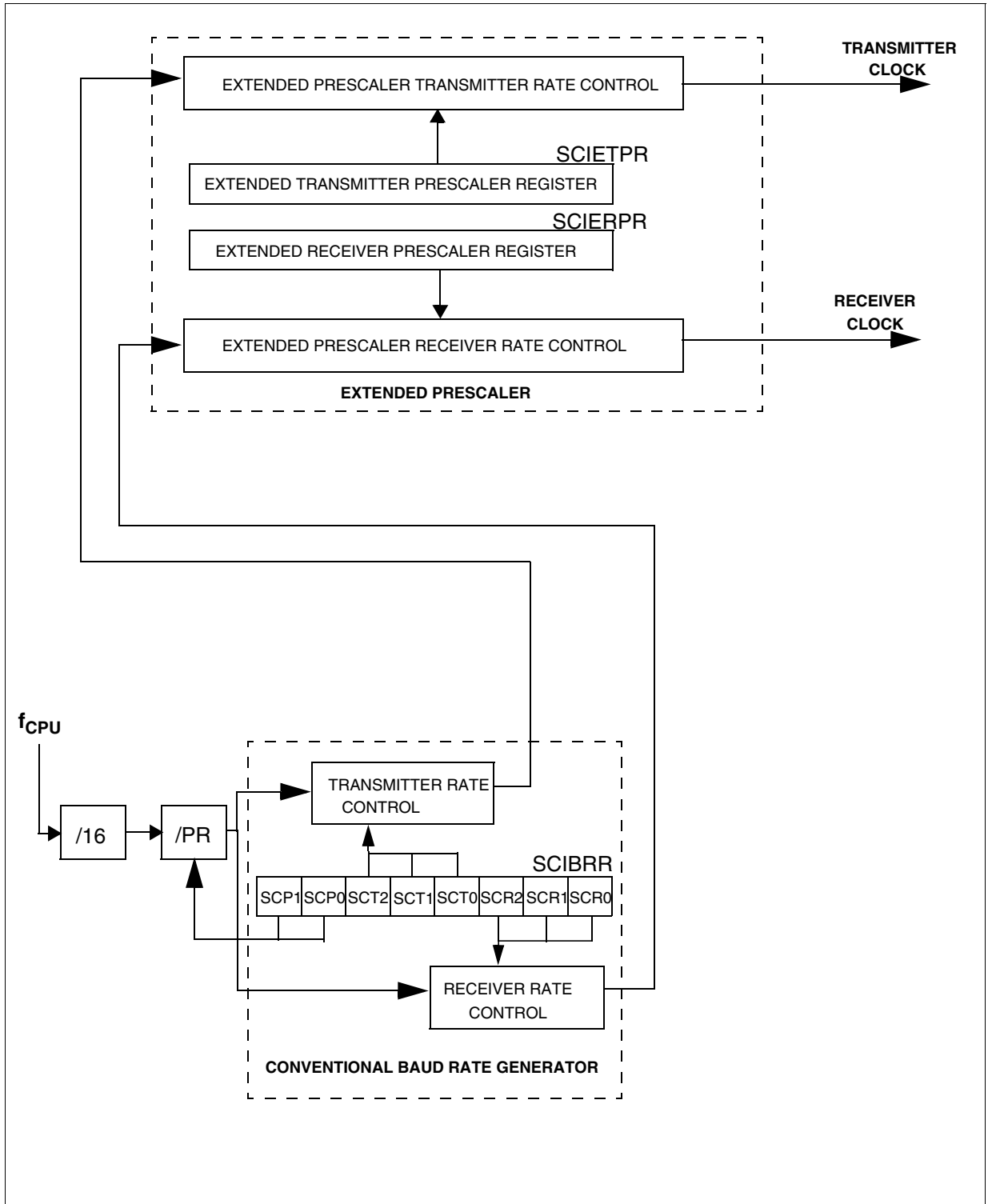

ASYNCHRONOUS SERIAL COMMUNICATIONS INTERFACE (Cont'd)

10.6.4.4 Conventional Baud Rate Generation

The baud rate for the receiver and transmitter (Rx and Tx) are set independently and calculated as follows:

$$Tx = \frac{f_{CPU}}{(16 \cdot PR) \cdot TR} \quad Rx = \frac{f_{CPU}}{(16 \cdot PR) \cdot RR}$$

with:

PR = 1, 3, 4 or 13 (see SCP[1:0] bits)

TR = 1, 2, 4, 8, 16, 32, 64, 128

(see SCT[2:0] bits)

RR = 1, 2, 4, 8, 16, 32, 64, 128

(see SCR[2:0] bits)

All this bits are in the SCIBRR register.

Example: If f_{CPU} is 24 MHz and if PR=13 and TR=RR=2, the transmit and receive baud rates are 57700 baud.

Note: The baud rate registers MUST NOT be changed while the transmitter or the receiver is enabled.

10.6.4.5 Extended Baud Rate Generation

The extended prescaler option gives a very fine tuning on the baud rate, using a 255 value prescaler, whereas the conventional Baud Rate Generator retains industry standard software compatibility.

The extended Baud Rate Generator block diagram is described in the [Figure 119](#).

The output clock rate sent to the transmitter or to the receiver will be the output from the 16 divider divided by a factor ranging from 1 to 255 set in the SCIERPR or the SCIETPR register.

Note: The extended prescaler is activated by setting the SCIETPR or SCIERPR register to a value other than zero. The baud rates are calculated as follows:

$$Tx = \frac{f_{CPU}}{16 \cdot ETPR \cdot (PR \cdot TR)} \quad Rx = \frac{f_{CPU}}{16 \cdot ERPR \cdot (PR \cdot TR)}$$

with:

ETPR = 1,...,255 (see SCIETPR register)

ERPR = 1,.. 255 (see SCIERPR register)

10.6.4.6 Receiver Muting and Wake-up Feature

In multiprocessor configurations it is often desirable that only the intended message recipient should actively receive the full message contents, thus reducing redundant SCI service overhead for all non addressed receivers.

The non addressed devices may be placed in sleep mode by means of the muting function.

Setting the RWU bit by software puts the SCI in sleep mode:

All the reception status bits can not be set.

All the receive interrupt are inhibited.

A muted receiver may be awakened by one of the following two ways:

- by Idle Line detection if the WAKE bit is reset,
- by Address Mark detection if the WAKE bit is set.

Receiver wakes-up by Idle Line detection when the Receive line has recognised an Idle Frame. Then the RWU bit is reset by hardware but the IDLE bit is not set.

Receiver wakes-up by Address Mark detection when it received a “1” as the most significant bit of a word, thus indicating that the message is an address. The reception of this particular word wakes up the receiver, resets the RWU bit and sets the RDRF bit, which allows the receiver to receive this word normally and to use it as an address word.

M Bit	PCE Bit	SCI Frame
0	0	SB 8 bit data STB
0	1	SB 7-bit data PB STB
1	0	SB 9-bit data STB
1	1	SB 8-bit data PB STB

SB : Start Bit

STB : Stop Bit

PB : Parity Bit

Note: In case of wake up by an address mark, the MSB bit of the data is taken into account and not the parity bit

ASYNCHRONOUS SERIAL COMMUNICATIONS INTERFACE (Cont'd)

10.6.4.7 Parity definition

Even parity: The parity bit is calculated to obtain an even number of “1s” inside the frame made of the 7 or 8 LSB bits (depending on whether M is equal to 0 or 1) and the parity bit.

Ex: data=00110101; 4 bits set => parity bit will be 0 if even parity is selected (PS bit = 0).

Odd parity: The parity bit is calculated to obtain an odd number of “1s” inside the frame made of the 7 or 8 LSB bits (depending on whether M is equal to 0 or 1) and the parity bit.

Ex: data=00110101; 4 bits set => parity bit will be 1 if odd parity is selected (PS bit = 1).

Transmission mode: If the PCE bit is set then the MSB bit of the data written in the data register is not transmitted but is changed by the parity bit.

Reception mode: If the PCE bit is set then the interface checks if the received data byte has an even number of “1s” if even parity is selected (PS=0) or an odd number of “1s” if odd parity is selected (PS=1). If the parity check fails, the PE flag is set in the SCISR register and an interrupt is generated if PCIE is set in the SCICR1 register.

ASYNCHRONOUS SERIAL COMMUNICATIONS INTERFACE (Cont'd)

10.6.5 Register Description

STATUS REGISTER (SCISR)

R240 - Read Only

Register Page: 26

Reset Value: 1100 0000 (C0h)

7							0
TDRE	TC	RDRF	IDLE	OR	NF	FE	PE

Bit 7 = TDRE *Transmit data register empty.*
 This bit is set by hardware when the content of the TDR register has been transferred into the shift register. An interrupt is generated if the TIE =1 in the SCICR2 register. It is cleared by a software sequence (an access to the SCISR register followed by a write to the SCIDR register).

0: Data is not transferred to the shift register
 1: Data is transferred to the shift register

Note: data will not be transferred to the shift register as long as the TDRE bit is not reset.

Bit 6 = TC *Transmission complete.*
 This bit is set by hardware when transmission of a frame containing Data, a Preamble or a Break is complete. An interrupt is generated if TCIE=1 in the SCICR2 register. It is cleared by a software sequence (an access to the SCISR register followed by a write to the SCIDR register).

0: Transmission is not complete
 1: Transmission is complete

Bit 5 = RDRF *Received data ready flag.*
 This bit is set by hardware when the content of the RDR register has been transferred into the SCIDR register. An interrupt is generated if RIE=1 in the SCICR2 register. It is cleared by hardware when RE=0 or by a software sequence (an access to the SCISR register followed by a read to the SCIDR register).

0: Data is not received
 1: Received data is ready to be read

Bit 4 = IDLE *Idle line detect.*
 This bit is set by hardware when an Idle Line is detected. An interrupt is generated if the ILIE=1 in the SCICR2 register. It is cleared by hardware when RE=0 by a software sequence (an access to

the SCISR register followed by a read to the SCIDR register).

0: No Idle Line is detected
 1: Idle Line is detected

Note: The IDLE bit will not be set again until the RDRF bit has been set itself (i.e. a new idle line occurs). This bit is not set by an idle line when the receiver wakes up from wake-up mode.

Bit 3 = OR *Overrun error.*
 This bit is set by hardware when the word currently being received in the shift register is ready to be transferred into the RDR register while RDRF=1. An interrupt is generated if RIE=1 in the SCICR2 register. It is cleared by hardware when RE=0 by a software sequence (an access to the SCISR register followed by a read to the SCIDR register).

0: No Overrun error
 1: Overrun error is detected

Note: When this bit is set RDR register content will not be lost but the shift register will be overwritten.

Bit 2 = NF *Noise flag.*
 This bit is set by hardware when noise is detected on a received frame. It is cleared by hardware when RE=0 by a software sequence (an access to the SCISR register followed by a read to the SCIDR register).

0: No noise is detected
 1: Noise is detected

Note: This bit does not generate interrupt as it appears at the same time as the RDRF bit which itself generates an interrupt.

Bit 1 = FE *Framing error.*
 This bit is set by hardware when a de-synchronization, excessive noise or a break character is detected. It is cleared by hardware when RE=0 by a software sequence (an access to the SCISR register followed by a read to the SCIDR register).

0: No Framing error is detected
 1: Framing error or break character is detected

Note: This bit does not generate interrupt as it appears at the same time as the RDRF bit which itself generates an interrupt. If the word currently being transferred causes both frame error and overrun error, it will be transferred and only the OR bit will be set.

ASYNCHRONOUS SERIAL COMMUNICATIONS INTERFACE (Cont'd)

Bit 0 = **PE** *Parity error.*

This bit is set by hardware when a parity error occurs in receiver mode. It is cleared by a software sequence (a read to the status register followed by an access to the SCIDR data register). An interrupt is generated if PIE=1 in the SCICR1 register.

0: No parity error
1: Parity error

Note: The M bit must not be modified during a data transfer (both transmission and reception).

Bit 3 = **WAKE** *Wake-Up method.*

This bit determines the SCI Wake-Up method, it is set or cleared by software.

0: Idle Line
1: Address Mark

CONTROL REGISTER 1 (SCICR1)

R243 - Read/Write

Register Page: 26

Reset Value: x000 0000 (x0h)

7							0
R8	T8	SCID	M	WAKE	PCE	PS	PIE

Bit 7 = **R8** *Receive data bit 8.*

This bit is used to store the 9th bit of the received word when M=1.

Bit 6 = **T8** *Transmit data bit 8.*

This bit is used to store the 9th bit of the transmitted word when M=1.

Bit 5 = **SCID** *Disabled for low power consumption*

When this bit is set the SCI prescalers and outputs are stopped and the end of the current byte transfer in order to reduce power consumption. This bit is set and cleared by software.

0: SCI enabled
1: SCI prescaler and outputs disabled

Bit 4 = **M** *Word length.*

This bit determines the word length. It is set or cleared by software.

0: 1 Start bit, 8 Data bits, 1 Stop bit
1: 1 Start bit, 9 Data bits, 1 Stop bit

Bit 2 = **PCE** *Parity control enable.*

This bit selects the hardware parity control (generation and detection). When the parity control is enabled, the computed parity is inserted at the MSB position (9th bit if M=1; 8th bit if M=0) and parity is checked on receive data. This bit is set and cleared by software. Once it is set, PCE is active after the current byte (in reception and in transmission).

0: Parity control disabled
1: Parity control enabled

Bit 1 = **PS** *Parity selection.*

This bit selects the odd or even parity when the parity generation/detection is enabled (PCE bit set). It is set and cleared by software. The parity will be selected after the current byte.

0: Even parity
1: Odd parity

Bit 0 = **PIE** *Parity interrupt enable.*

This bit enables the interrupt capability of the hardware parity control when a parity error is detected (PE bit set). It is set and cleared by software.

0: Parity error interrupt disabled
1: Parity error interrupt enabled

Note: The ITEI0 bit in the SITRH register (See Interrupts Chapter) must be set to enable the SCI-A interrupt as the SCI-A interrupt is a rising edge event.

ASYNCHRONOUS SERIAL COMMUNICATIONS INTERFACE (Cont'd)

CONTROL REGISTER 2 (SCICR2)

R244 - Read/Write

Register Page: 26

Reset Value: 0000 0000 (00h)

TIE	TCIE	RIE	ILIE	TE	RE	RWU	SBK		

Bit 7 = **TIE** *Transmitter interrupt enable*.
 This bit is set and cleared by software.
 0: Interrupt is inhibited
 1: An SCI interrupt is generated whenever TDRE=1 in the SCISR register

Bit 6 = **TCIE** *Transmission complete interrupt enable*
 This bit is set and cleared by software.
 0: Interrupt is inhibited
 1: An SCI interrupt is generated whenever TC=1 in the SCISR register

Bit 5 = **RIE** *Receiver interrupt enable*.
 This bit is set and cleared by software.
 0: Interrupt is inhibited
 1: An SCI interrupt is generated whenever OR=1 or RDRF=1 in the SCISR register

Bit 4 = **ILIE** *Idle line interrupt enable*.
 This bit is set and cleared by software.
 0: Interrupt is inhibited
 1: An SCI interrupt is generated whenever IDLE=1 in the SCISR register.

Bit 3 = **TE** *Transmitter enable*.
 This bit enables the transmitter. It is set and cleared by software.
 0: Transmitter is disabled, the TDO pin is in high impedance
 1: Transmitter is enabled

Note: during transmission, a “0” pulse on the TE bit (“0” followed by “1”) sends a preamble after the current word.

Bit 2 = **RE** *Receiver enable*.
 This bit enables the receiver. It is set and cleared by software.
 0: Receiver is disabled, it resets the RDRF, IDLE, OR, NF and FE bits of the SCISR register
 1: Receiver is enabled and begins searching for a start bit

Bit 1 = **RWU** *Receiver wake-up*.
 This bit determines if the SCI is in mute mode or not. It is set and cleared by software and can be cleared by hardware when a wake-up sequence is recognized.
 0: Receiver in active mode
 1: Receiver in mute mode

Bit 0 = **SBK** *Send break*.
 This bit set is used to send break characters. It is set and cleared by software.
 0: No break character is transmitted
 1: Break characters are transmitted

Notes:

- If the SBK bit is set to “1” and then to “0”, the transmitter will send a BREAK word at the end of the current word.
- The ITEI0 bit in the SITRH register (See Interrupts Chapter) must be set to enable the SCI-A interrupt as the SCI-A interrupt is a rising edge event.

CONTROL REGISTER 3 (SCICR3)

R255 - Read/Write

Register Page: 26

Reset Value: 0000 0000 (00h)

-	LINE	-	-	-	-	-	-	-	-

Bit 7 = Reserved

Bit 6 = **LINE** *LIN mode Enable*.
 This bit is set and cleared by software.
 0: LIN master mode disabled
 1: LIN master mode enabled

LIN master mode enables the capability to send LIN Synch Breaks (13 low bits) using the SBK bit in the SCICR2 register. In transmission, the LIN Synch Break low phase duration is shown as below:

LINE	M	Number of low bits sent during a LIN Synch Break
0	0	10
0	1	11
1	0	13
1	1	14

Bits 5:0 = Reserved

ASYNCHRONOUS SERIAL COMMUNICATIONS INTERFACE (Cont'd)

DATA REGISTER (SCIDR)

R241 - Read/Write
 Register Page: 26
 Reset Value: Undefined

Contains the Received or Transmitted data character, depending on whether it is read from or written to.

7							0
DR7	DR6	DR5	DR4	DR3	DR2	DR1	DR0

The Data register performs a double function (read and write) since it is composed of two registers, one for transmission (TDR) and one for reception (RDR).

The TDR register provides the parallel interface between the internal bus and the output shift register (see [Figure 117](#)).

The RDR register provides the parallel interface between the input shift register and the internal bus (see [Figure 117](#)).

BAUD RATE REGISTER (SCIBRR)

R242 - Read/Write
 Register Page: 26
 Reset Value: 00xx xxxx (xxh)

7							0
SCP1	SCP0	SCT2	SCT1	SCT0	SCR2	SCR1	SCR0

Bits 7:6= **SCP[1:0]** *First SCI Prescaler*
 These 2 prescaling bits allow several standard clock division ranges:

PR Prescaling factor	SCP1	SCP0
1	0	0
3	0	1
4	1	0
13	1	1

Bits 5:3 = **SCT[2:0]** *SCI Transmitter rate divisor*
 These 3 bits, in conjunction with the SCP1 & SCP0 bits define the total division applied to the bus clock to yield the transmit rate clock in conventional Baud Rate Generator mode.

TR Dividing Factor	SCT2	SCT1	SCT0
1	0	0	0
2	0	0	1
4	0	1	0
8	0	1	1
16	1	0	0
32	1	0	1
64	1	1	0
128	1	1	1

Note: This TR factor is used only when the ETPR fine tuning factor is equal to 00h; otherwise, TR is replaced by the (TR*ETPR) dividing factor.

Bits 2:0 = **SCR[2:0]** *SCI Receiver rate divisor*
 These 3 bits, in conjunction with the SCP1 & SCP0 bits define the total division applied to the bus clock to yield the receive rate clock in conventional Baud Rate Generator mode.

RR Dividing Factor	SCR2	SCR1	SCR0
1	0	0	0
2	0	0	1
4	0	1	0
8	0	1	1
16	1	0	0
32	1	0	1
64	1	1	0
128	1	1	1

Note: This RR factor is used only when the ERPR fine tuning factor is equal to 00h; otherwise, RR is replaced by the (RR*ERPR) dividing factor.

ASYNCHRONOUS SERIAL COMMUNICATIONS INTERFACE (Cont'd)

EXTENDED RECEIVE PRESCALER DIVISION REGISTER (SCIERPR)

R245 - Read/Write
 Register Page: 26
 Reset Value: 0000 0000 (00h)

Allows setting of the Extended Prescaler rate division factor for the receive circuit.

7									0
ERPR7	ERPR6	ERPR5	ERPR4	ERPR3	ERPR2	ERPR1	ERPR0		

Bits 7:1 = **ERPR[7:0]** 8-bit Extended Receive Prescaler Register.

The extended Baud Rate Generator is activated when a value different from 00h is stored in this register. Therefore the clock frequency issued from the 16 divider (see [Figure 119](#)) is divided by the binary factor set in the SCIERPR register (in the range 1 to 255).

The extended Baud Rate Generator is not used after a reset.

EXTENDED TRANSMIT PRESCALER DIVISION REGISTER (SCIETPR)

R246 - Read/Write
 Register Page: 26
 Reset Value: 0000 0000 (00h)

Allows setting of the External Prescaler rate division factor for the transmit circuit.

7									0
ETPR7	ETPR6	ETPR5	ETPR4	ETPR3	ETPR2	ETPR1	ETPR0		

Bits 7:1 = **ETPR[7:0]** 8-bit Extended Transmit Prescaler Register.

The extended Baud Rate Generator is activated when a value different from 00h is stored in this register. Therefore the clock frequency issued from the 16 divider (see [Figure 119](#)) is divided by the binary factor set in the SCIETPR register (in the range 1 to 255).

The extended Baud Rate Generator is not used after a reset.

10.6.6 Important Notes on SCI-A

Refer to [Section 13.4 on page 413](#) and [Section 13.5 on page 413](#).

10.7 SERIAL PERIPHERAL INTERFACE (SPI)

10.7.1 Introduction

The Serial Peripheral Interface (SPI) allows full-duplex, synchronous, serial communication with external devices. An SPI system may consist of a master and one or more slaves or a system in which devices may be either masters or slaves.

The SPI is normally used for communication between the microcontroller and external peripherals or another Microcontroller.

Refer to the Pin Description chapter for the device-specific pin-out.

10.7.2 Main Features

- Full duplex, three-wire synchronous transfers
- Master or slave operation
- Maximum slave mode frequency = INTCLK/2.
- Programmable prescalers for a wide range of baud rates
- Programmable clock polarity and phase
- End of transfer interrupt flag
- Write collision flag protection
- Master mode fault protection capability.

10.7.3 General Description

The SPI is connected to external devices through 4 alternate function pins:

- MISO: Master In Slave Out pin

- MOSI: Master Out Slave In pin
- SCK: Serial Clock pin
- \overline{SS} : Slave select pin

To use any of these alternate functions (input or output), the corresponding I/O port must be programmed as alternate function output.

A basic example of interconnections between a single master and a single slave is illustrated on [Figure 120](#).

The MOSI pins are connected together as are MISO pins. In this way data is transferred serially between master and slave.

When the master device transmits data to a slave device via MOSI pin, the slave device responds by sending data to the master device via the MISO pin. This implies full duplex transmission with both data out and data in synchronized with the same clock signal (which is provided by the master device via the SCK pin).

Thus, the byte transmitted is replaced by the byte received and eliminates the need for separate transmit-empty and receiver-full bits. A status flag is used to indicate that the I/O operation is complete.

Various data/clock timing relationships may be chosen (see [Figure 123](#)) but master and slave must be programmed with the same timing mode.

Figure 120. Serial Peripheral Interface Master/Slave

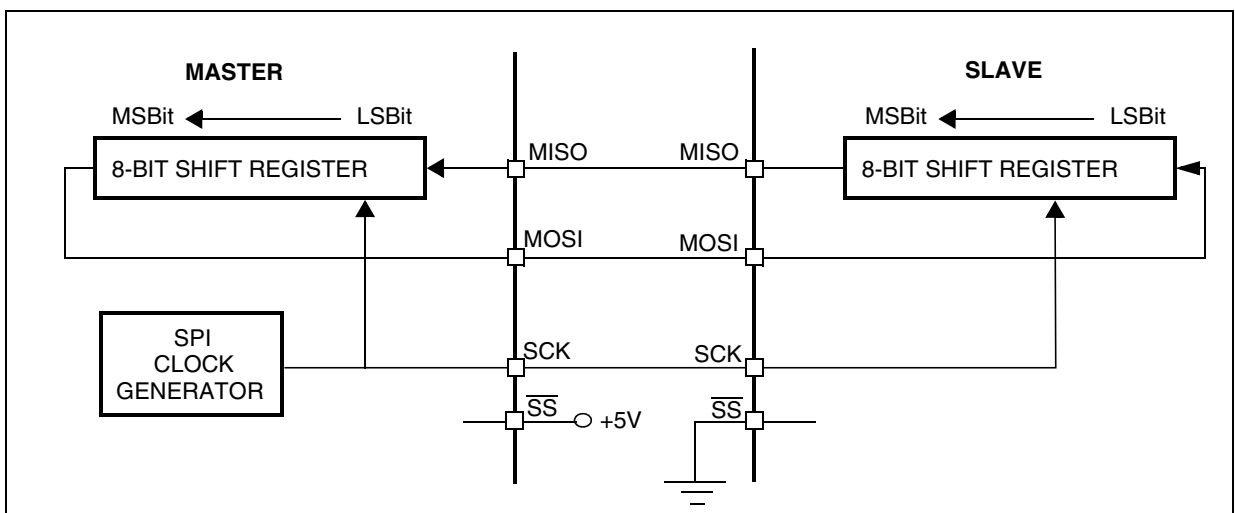

SERIAL PERIPHERAL INTERFACE (Cont'd)

Figure 121. Serial Peripheral Interface Block Diagram

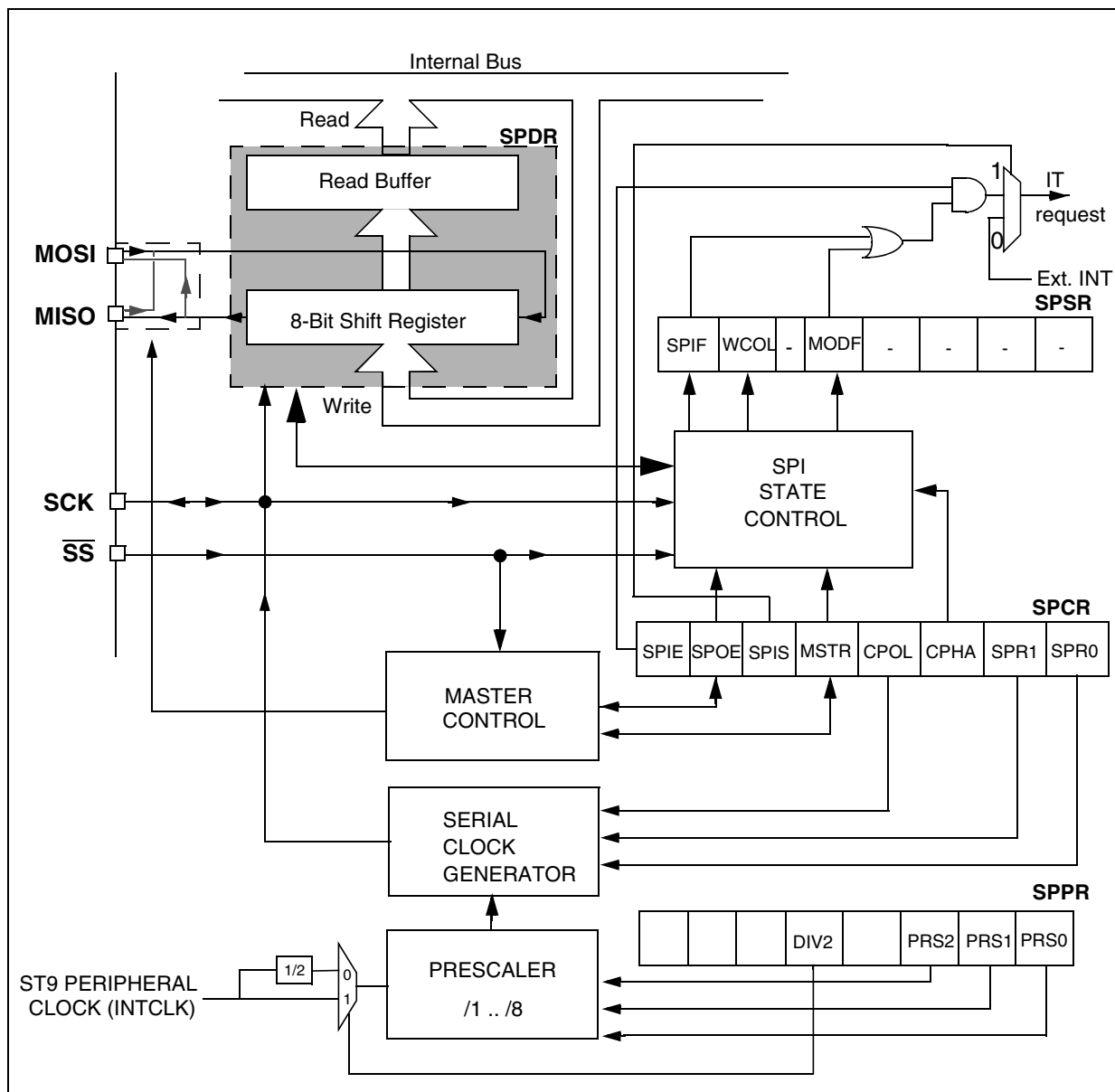

SERIAL PERIPHERAL INTERFACE (Cont'd)

10.7.4 Functional Description

Figure 121 shows the serial peripheral interface (SPI) block diagram.

This interface contains 4 dedicated registers:

- A Control Register (SPCR)
- A Prescaler Register (SPPR)
- A Status Register (SPSR)
- A Data Register (SPDR)

Refer to the SPCR, SPPR, SPSR and SPDR registers in Section 10.7.6 for the bit definitions.

10.7.4.1 Master Configuration

In a master configuration, the serial clock is generated on the SCK pin.

Procedure

- Define the serial clock baud rate by setting/resetting the DIV2 bit of SPPR register, by writing a prescaler value in the SPPR register and programming the SPR0 & SPR1 bits in the SPCR register.
- Select the CPOL and CPHA bits to define one of the four relationships between the data transfer and the serial clock (see Figure 123).
- The \overline{SS} pin must be connected to a high level signal during the complete byte transmit sequence.
- The MSTR and SPOE bits must be set (they remain set only if the \overline{SS} pin is connected to a high level signal).

In this configuration the MOSI pin is a data output and the MISO pin is a data input.

Transmit Sequence

The transmit sequence begins when a byte is written the SPDR register.

The data byte is parallel loaded into the 8-bit shift register (from the internal bus) during a write cycle and then shifted out serially to the MOSI pin most significant bit first.

When data transfer is complete:

- The SPIF bit is set by hardware
- An interrupt is generated if the SPIS and SPIE bits are set.

During the last clock cycle the SPIF bit is set, a copy of the data byte received in the shift register is moved to a buffer. When the SPDR register is read, the SPI peripheral returns this buffered value.

Clearing the SPIF bit is performed by the following software sequence:

1. An access to the SPSR register while the SPIF bit is set
2. A read of the SPDR register.

Note: While the SPIF bit is set, all writes to the SPDR register are inhibited until the SPSR register is read.

SERIAL PERIPHERAL INTERFACE (Cont'd)**10.7.4.2 Slave Configuration**

In slave configuration, the serial clock is received on the SCK pin from the master device.

The value of the SPPR register and SPR0 & SPR1 bits in the SPCR is not used for the data transfer.

Procedure

- For correct data transfer, the slave device must be in the same timing mode as the master device (CPOL and CPHA bits). See [Figure 123](#).
- The \overline{SS} pin must be connected to a low level signal during the complete byte transmit sequence.
- Clear the MSTR bit and set the SPOE bit to assign the pins to alternate function.

In this configuration the MOSI pin is a data input and the MISO pin is a data output.

Transmit Sequence

The data byte is parallel loaded into the 8-bit shift register (from the internal bus) during a write cycle and then shifted out serially to the MISO pin most significant bit first.

The transmit sequence begins when the slave device receives the clock signal and the most significant bit of the data on its MOSI pin.

When data transfer is complete:

- The SPIF bit is set by hardware
- An interrupt is generated if the SPIS and SPIE bits are set.

During the last clock cycle the SPIF bit is set, a copy of the data byte received in the shift register is moved to a buffer. When the SPDR register is read, the SPI peripheral returns this buffered value.

Clearing the SPIF bit is performed by the following software sequence:

1. An access to the SPSR register while the SPIF bit is set.
2. A read of the SPDR register.

Notes: While the SPIF bit is set, all writes to the SPDR register are inhibited until the SPSR register is read.

The SPIF bit can be cleared during a second transmission; however, it must be cleared before the second SPIF bit in order to prevent an overrun condition (see [Section 10.7.4.6](#)).

Depending on the CPHA bit, the \overline{SS} pin has to be set to write to the SPDR register between each data byte transfer to avoid a write collision (see [Section 10.7.4.4](#)).

SERIAL PERIPHERAL INTERFACE (Cont'd)

10.7.4.3 Data Transfer Format

During an SPI transfer, data is simultaneously transmitted (shifted out serially) and received (shifted in serially). The serial clock is used to synchronize the data transfer during a sequence of eight clock pulses.

The \overline{SS} pin allows individual selection of a slave device; the other slave devices that are not selected do not interfere with the SPI transfer.

Clock Phase and Clock Polarity

Four possible timing relationships may be chosen by software, using the CPOL and CPHA bits.

The CPOL (clock polarity) bit controls the steady state value of the clock when no data is being transferred. This bit affects both master and slave modes.

The combination between the CPOL and CPHA (clock phase) bits selects the data capture clock edge.

Figure 123 shows an SPI transfer with the four combinations of the CPHA and CPOL bits. The diagram may be interpreted as a master or slave timing diagram where the SCK pin, the MISO pin, the MOSI pin are directly connected between the master and the slave device.

The \overline{SS} pin is the slave device select input and can be driven by the master device.

The master device applies data to its MOSI pin-clock edge before the capture clock edge.

CPHA Bit is Set

The second edge on the SCK pin (falling edge if the CPOL bit is reset, rising edge if the CPOL bit is set) is the MSBit capture strobe. Data is latched on the occurrence of the first clock transition.

No write collision should occur even if the \overline{SS} pin stays low during a transfer of several bytes (see Figure 122).

CPHA Bit is Reset

The first edge on the SCK pin (falling edge if CPOL bit is set, rising edge if CPOL bit is reset) is the MSBit capture strobe. Data is latched on the occurrence of the second clock transition.

This pin must be toggled high and low between each byte transmitted (see Figure 122).

To protect the transmission from a write collision a low value on the \overline{SS} pin of a slave device freezes the data in its SPDR register and does not allow it to be altered. Therefore the \overline{SS} pin must be high to write a new data byte in the SPDR without producing a write collision.

Figure 122. CPHA / \overline{SS} Timing Diagram

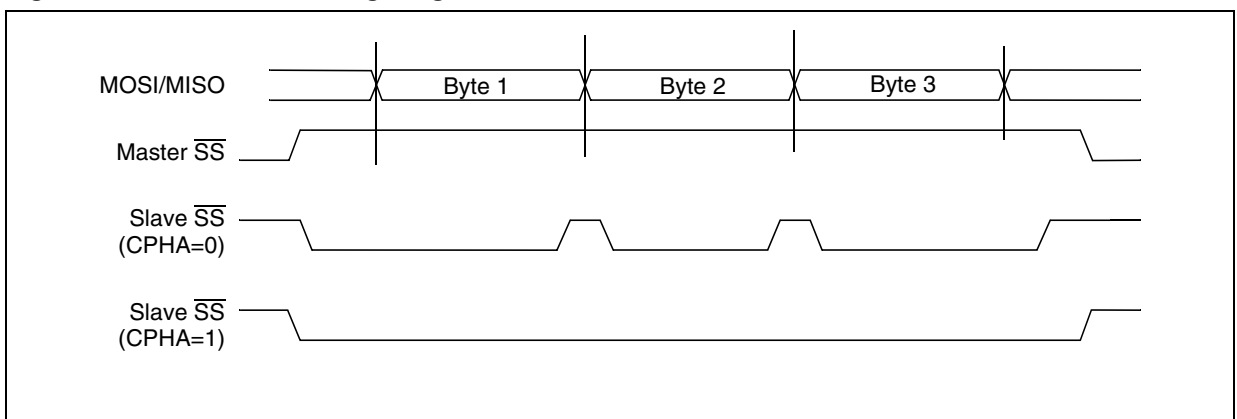

SERIAL PERIPHERAL INTERFACE (Cont'd)

Figure 123. Data Clock Timing Diagram

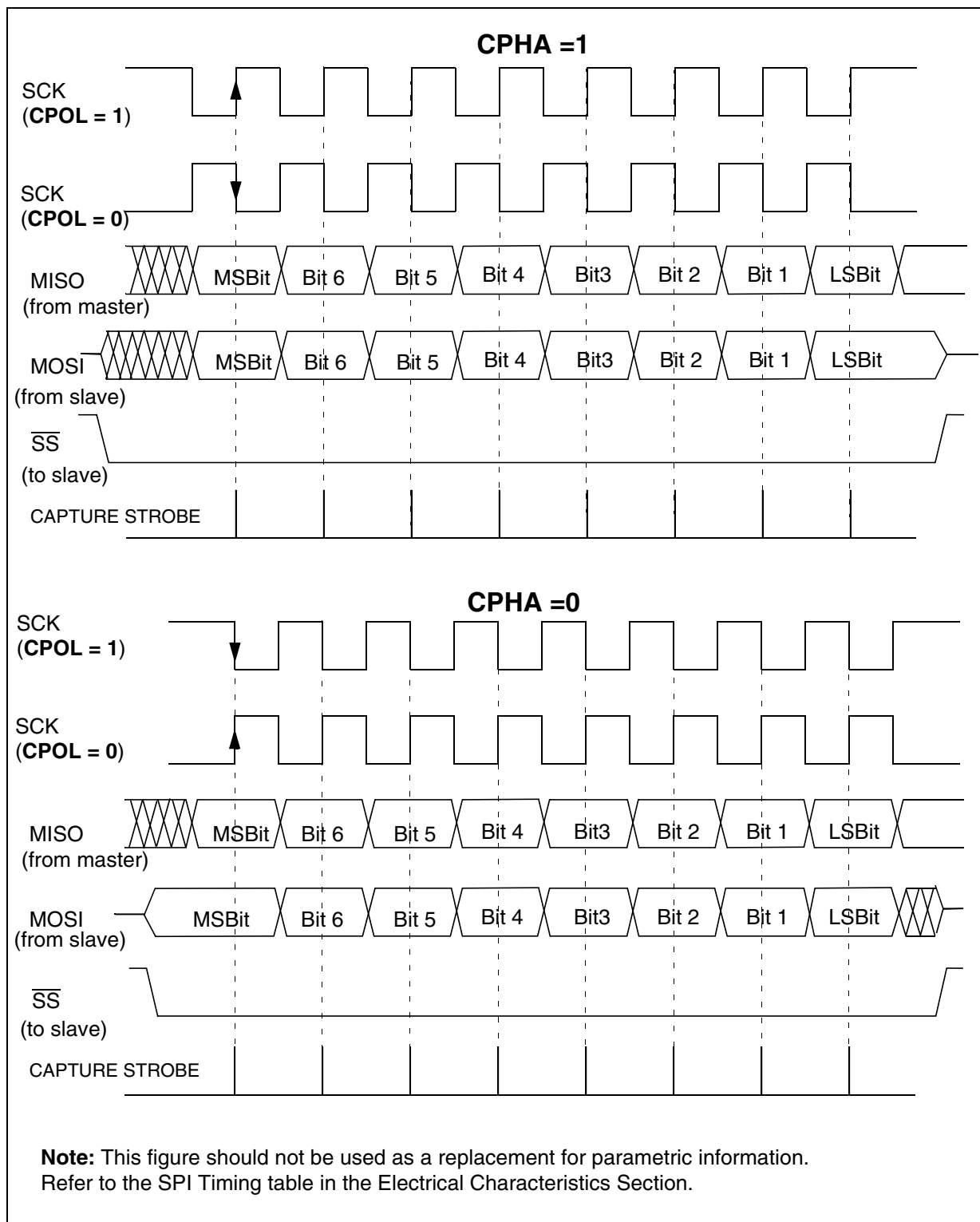

SERIAL PERIPHERAL INTERFACE (Cont'd)

10.7.4.4 Write Collision Error

A write collision occurs when the software tries to write to the SPDR register while a data transfer is taking place with an external device. When this happens, the transfer continues uninterrupted and the software write will be unsuccessful.

Write collisions can occur both in master and slave mode.

Note: a "read collision" will never occur since the received data byte is placed in a buffer in which access is always synchronous with the MCU operation.

In Slave mode

When the CPHA bit is set:

The slave device will receive a clock (SCK) edge prior to the latch of the first data transfer. This first clock edge will freeze the data in the slave device SPDR register and output the MSBit on to the external MISO pin of the slave device.

The \overline{SS} pin low state enables the slave device but the output of the MSBit onto the MISO pin does not take place until the first data transfer clock edge.

When the CPHA bit is reset:

Data is latched on the occurrence of the first clock transition. The slave device does not have any way of knowing when that transition will occur; therefore, the slave device collision occurs when software attempts to write the SPDR register after its \overline{SS} pin has been pulled low.

For this reason, the \overline{SS} pin must be high, between each data byte transfer, to allow the CPU to write in the SPDR register without generating a write collision.

In Master mode

Collision in the master device is defined as a write of the SPDR register while the internal serial clock (SCK) is in the process of transfer.

The \overline{SS} pin signal must be always high on the master device.

WCOL Bit

The WCOL bit in the SPSR register is set if a write collision occurs.

No SPI interrupt is generated when the WCOL bit is set (the WCOL bit is a status flag only).

Clearing the WCOL bit is done through a software sequence (see [Figure 124](#)).

Figure 124. Clearing the WCOL bit (Write Collision Flag) Software Sequence

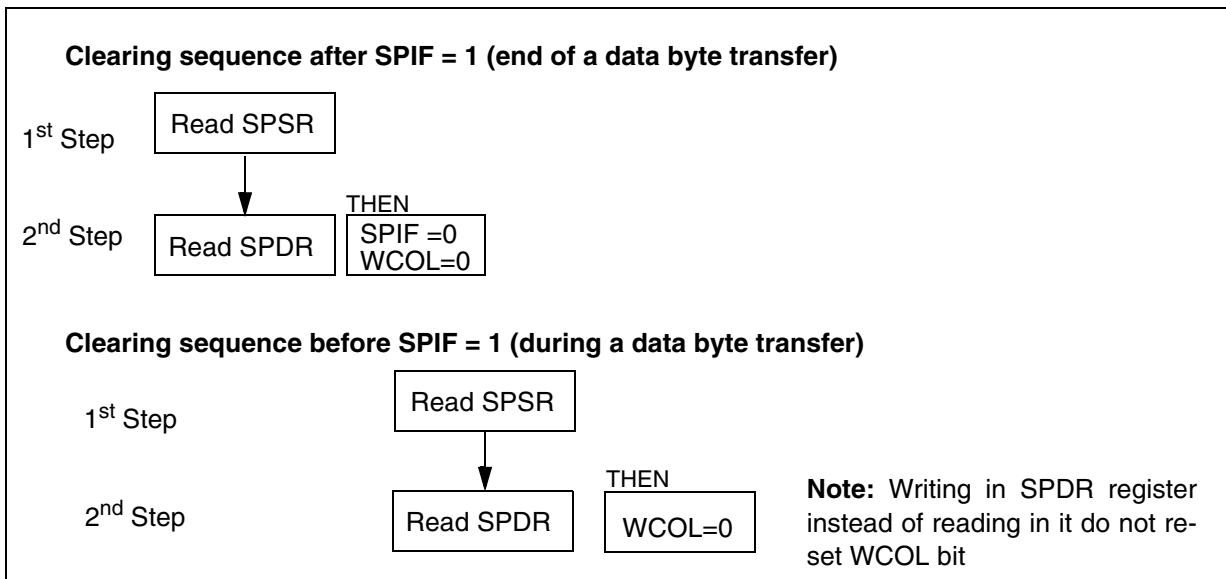

SERIAL PERIPHERAL INTERFACE (Cont'd)

10.7.4.5 Master Mode Fault

Master mode fault occurs when the master device has its \overline{SS} pin pulled low, then the MODF bit is set.

Master mode fault affects the SPI peripheral in the following ways:

- The MODF bit is set and an SPI interrupt is generated if the SPIE bit is set.
- The SPOE bit is reset. This blocks all output from the device and disables the SPI peripheral.
- The MSTR bit is reset, thus forcing the device into slave mode.

Clearing the MODF bit is done through a software sequence:

1. A read access to the SPSR register while the MODF bit is set.
2. A write to the SPCR register.

Notes: To avoid any multiple slave conflicts in the case of a system comprising several MCUs, the \overline{SS} pin must be pulled high during the clearing sequence of the MODF bit. The SPOE and MSTR

bits may be restored to their original state during or after this clearing sequence.

Hardware does not allow the user to set the SPOE and MSTR bits while the MODF bit is set except in the MODF bit clearing sequence.

In a slave device the MODF bit can not be set, but in a multi master configuration the device can be in slave mode with this MODF bit set.

The MODF bit indicates that there might have been a multi-master conflict for system control and allows a proper exit from system operation to a reset or default system state using an interrupt routine.

10.7.4.6 Overrun Condition

An overrun condition occurs, when the master device has sent several data bytes and the slave device has not cleared the SPIF bit issuing from the previous data byte transmitted.

In this case, the receiver buffer contains the byte sent after the SPIF bit was last cleared. A read to the SPDR register returns this byte. All other bytes are lost.

This condition is not detected by the SPI peripheral.

SERIAL PERIPHERAL INTERFACE (Cont'd)

10.7.4.7 Single Master and Multimaster Configurations

There are two types of SPI systems:

- Single Master System
- Multimaster System

Single Master System

A typical single master system may be configured, using an MCU as the master and four MCUs as slaves (see [Figure 125](#)).

The master device selects the individual slave devices by using four pins of a parallel port to control the four \overline{SS} pins of the slave devices.

The \overline{SS} pins are pulled high during reset since the master device ports will be forced to be inputs at that time, thus disabling the slave devices.

Note: To prevent a bus conflict on the MISO line the master allows only one slave device during a transmission.

For more security, the slave device may respond to the master with the received data byte. Then the master will receive the previous byte back from the slave device if all MISO and MOSI pins are connected and the slave has not written its SPDR register.

Other transmission security methods can use ports for handshake lines or data bytes with command fields.

Multi-Master System

A multi-master system may also be configured by the user. Transfer of master control could be implemented using a handshake method through the I/O ports or by an exchange of code messages through the serial peripheral interface system.

The multi-master system is principally handled by the MSTR bit in the SPCR register and the MODF bit in the SPSR register.

Figure 125. Single Master Configuration

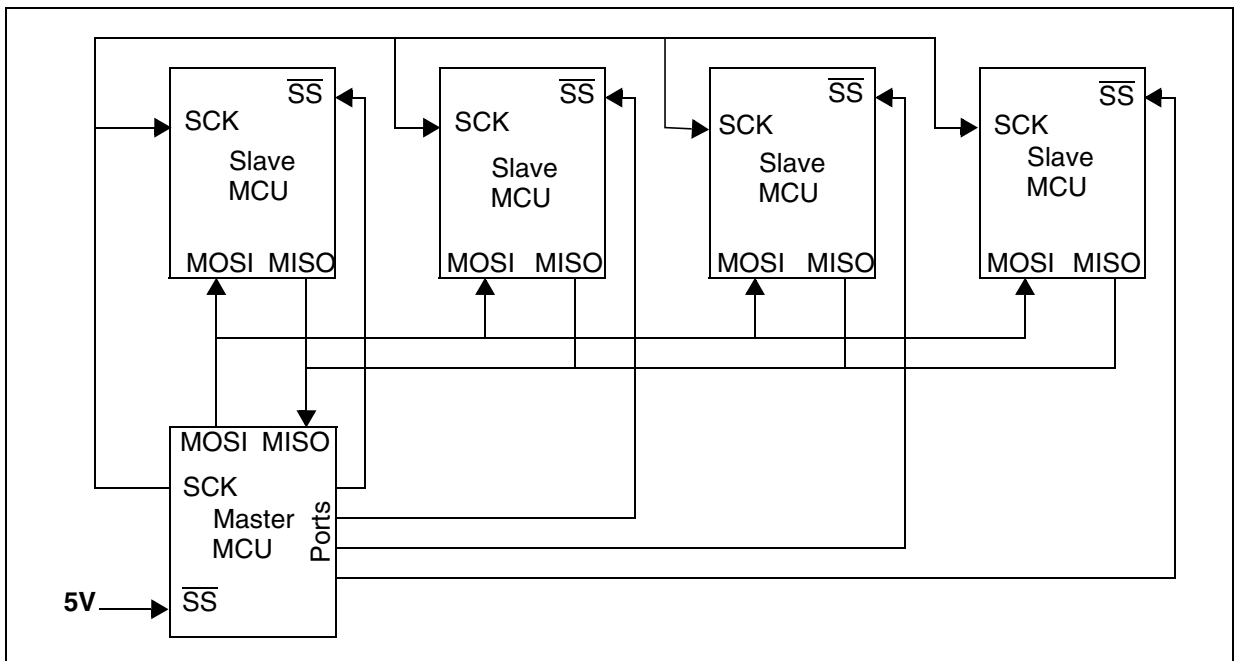

SERIAL PERIPHERAL INTERFACE (Cont'd)

10.7.5 Interrupt Management

The interrupt of the Serial Peripheral Interface is mapped on one of the eight External Interrupt Channels of the microcontroller (refer to the “Interrupts” chapter).

Each External Interrupt Channel has:

- A trigger control bit in the EITR register (R242 - Page 0),
- A pending bit in the EIPR register (R243 - Page0),
- A mask bit in the EIMR register (R244 - Page 0).

Program the interrupt priority level using the EIPLR register (R245 - Page 0). For a description of these registers refer to the “Interrupts” and “DMA” chapters.

To use the interrupt feature, perform the following sequence:

- Set the priority level of the interrupt channel used for the SPI (EIPRL register)
- Select the interrupt trigger edge as rising edge (set the corresponding bit in the EITR register)
- Set the SPIS bit of the SPCR register to select the peripheral interrupt source
- Set the SPIE bit of the SPCR register to enable the peripheral to perform interrupt requests
- In the EIPR register, reset the pending bit of the interrupt channel used by the SPI interrupt to avoid any spurious interrupt requests being performed when the mask bit is set
- Set the mask bit of the interrupt channel used to enable the MCU to acknowledge the interrupt requests of the peripheral.

Note: In the interrupt routine, reset the related pending bit to avoid the interrupt request that was just acknowledged being proposed again.

Then, after resetting the pending bit and before the IRET instruction, check if the SPIF and MODF interrupt flags in the SPSR register) are reset; otherwise jump to the beginning of the routine. If, on return from an interrupt routine, the pending bit is reset while one of the interrupt flags is set, no interrupt is performed on that channel until the flags are set. A new interrupt request is performed only when a flag is set with the other not set.

10.7.5.1 Register Map

Depending on the device, one or two Serial Peripheral interfaces can be present. The previous table summarizes the position of the registers of the two peripherals in the register map of the microcontroller.

	Address	Page	Name
SPI0	R240 (F0h)	7	DR0
	R241 (F1h)	7	CR0
	R242 (F2h)	7	SR0
SPI1	R243 (F3h)	7	PR0
	R248 (F8h)	7	DR1
	R249 (F9h)	7	CR1
	R250 (FAh)	7	SR1
	R251 (FBh)	7	PR1

SERIAL PERIPHERAL INTERFACE (Cont'd)

10.7.6 Register Description

DATA REGISTER (SPDR)

R240 - Read/Write

Register Page: 7

Reset Value: 0000 0000 (00h)

7							0
D7	D6	D5	D4	D3	D2	D1	D0

The SPDR register is used to transmit and receive data on the serial bus. In the master device only a write to this register will initiate transmission/reception of another byte.

Notes: During the last clock cycle the SPIF bit is set, a copy of the received data byte in the shift register is moved to a buffer. When the user reads the serial peripheral data register, the buffer is actually being read.

Warning: A write to the SPDR register places data directly into the shift register for transmission.

A read to the SPDR register returns the value located in the buffer and not the content of the shift register (see [Figure 121](#)).

CONTROL REGISTER (SPCR)

R241 - Read/Write

Register Page: 7

Reset Value: 0000 0000 (00h)

7							0
SPIE	SPOE	SPIS	MSTR	CPOL	CPHA	SPR1	SPR0

Bit 7 = **SPIE** *Serial peripheral interrupt enable*.

This bit is set and cleared by software.

0: Interrupt is inhibited

1: An SPI interrupt is generated whenever either SPIF or MODF are set in the SPSR register while the other flag is 0.

Bit 6 = **SPOE** *Serial peripheral output enable*.

This bit is set and cleared by software. It is also cleared by hardware when, in master mode, $\overline{SS}=0$ (see [Section 10.7.4.5 Master Mode Fault](#)).

0: SPI alternate functions disabled (MISO, MOSI and SCK can only work as input)

1: SPI alternate functions enabled (MISO, MOSI and SCK can work as input or output depending on the value of MSTR)

Note: To use the MISO, MOSI and SCK alternate functions (input or output), the corresponding I/O port must be programmed as alternate function output.

Bit 5 = **SPIS** *Interrupt Selection*.

This bit is set and cleared by software.

0: Interrupt source is external interrupt

1: Interrupt source is SPI

Bit 4 = **MSTR** *Master*.

This bit is set and cleared by software. It is also cleared by hardware when, in master mode, $\overline{SS}=0$ (see [Section 10.7.4.5 Master Mode Fault](#)).

0: Slave mode is selected

1: Master mode is selected, the function of the SCK pin changes from an input to an output and the functions of the MISO and MOSI pins are reversed.

Bit 3 = **CPOL** *Clock polarity*.

This bit is set and cleared by software. This bit determines the steady state of the serial Clock. The CPOL bit affects both the master and slave modes.

0: The steady state is a low value at the SCK pin.

1: The steady state is a high value at the SCK pin.

Bit 2 = **CPHA** *Clock phase*.

This bit is set and cleared by software.

0: The first clock transition is the first data capture edge.

1: The second clock transition is the first capture edge.

Bit 1:0 = **SPR[1:0]** *Serial peripheral rate*.

These bits are set and cleared by software. They select one of four baud rates to be used as the serial clock when the device is a master.

These 2 bits have no effect in slave mode.

Table 49. Serial Peripheral Baud Rate

INTCLK Clock Divide	SPR1	SPR0
2	0	0
4	0	1
16	1	0
32	1	1

SERIAL PERIPHERAL INTERFACE (Cont'd)

STATUS REGISTER (SPSR)

R242 - Read Only

Register Page: 7

Reset Value: 0000 0000 (00h)

7							0
SPIF	WCOL	-	MODF	-	-	-	-

Bit 7 = **SPIF** *Serial Peripheral data transfer flag*.
 This bit is set by hardware when a transfer has been completed. An interrupt is generated if SPIE=1 in the SPCR register. It is cleared by a software sequence (an access to the SPSR register followed by a read or write to the SPDR register).
 0: Data transfer is in progress or has been approved by a clearing sequence.
 1: Data transfer between the device and an external device has been completed.

Note: While the SPIF bit is set, all writes to the SPDR register are inhibited.

Bit 6 = **WCOL** *Write Collision status*.

This bit is set by hardware when a write to the SPDR register is done during a transmit sequence. It is cleared by a software sequence (see [Figure 124](#)).

0: No write collision occurred
 1: A write collision has been detected

Bit 5 = Unused.

Bit 4 = **MODF** *Mode Fault flag*.

This bit is set by hardware when the \overline{SS} pin is pulled low in master mode (see [Section 10.7.4.5 Master Mode Fault](#)). An SPI interrupt can be generated if SPIE=1 in the SPCR register. This bit is cleared by a software sequence (An access to the SPSR register while MODF=1 followed by a write to the SPCR register).

0: No master mode fault detected

1: A fault in master mode has been detected

Bits 3:0 = Unused.

PRESCALER REGISTER (SPPR)

R243 - Read/Write

Register Page: 7

Reset Value: 0000 0000 (00h)

7							0
0	0	0	DIV2	0	PRS2	PRS1	PRS0

Bits 7:5 = Reserved, forced by hardware to 0.

Bit 4 = **DIV2** *Divider enable*.

This bit is set and cleared by software.

0: Divider by 2 enabled.
 1: Divider by 2 disabled.

Bit 3 = Reserved. forced by hardware to 0.

Bits 2:0 = **PRS[2:0]** *Prescaler Value*.

These bits are set and cleared by software. The baud rate generator is driven by $INTCLK/(n1*n2*n3)$ where $n1 = PRS[2:0]+1$, $n2$ is the value defined by the SPR[1:0] bits (refer to [Table 49](#) and [Table 50](#)), $n3 = 1$ if DIV2=1 and $n3 = 2$ if DIV2=0. Refer to [Figure 121](#).

These bits have no effect in slave mode.

Table 50. Prescaler Baud Rate

Prescaler Division Factor	PRS2	PRS1	PRS0
1 (no division)	0	0	0
2	0	0	1
...			
8	1	1	1

10.8 I²C BUS INTERFACE

10.8.1 Introduction

The I²C bus Interface serves as an interface between the microcontroller and the serial I²C bus. It provides both multimaster and slave functions with both 7-bit and 10-bit address modes; it controls all I²C bus-specific sequencing, protocol, arbitration, timing and supports both standard (100KHz) and fast I²C modes (400KHz).

Using DMA, data can be transferred with minimum use of CPU time.

The peripheral uses two external lines to perform the protocols: SDA, SCL.

10.8.2 Main Features

- Parallel-bus/I²C protocol converter
- Multi-master capability
- 7-bit/10-bit Addressing
- Standard I²C mode/Fast I²C mode
- Transmitter/Receiver flag
- End-of-byte transmission flag
- Transfer problem detection
- Interrupt generation on error conditions
- Interrupt generation on transfer request and on data received

I²C Master Features:

- Start bit detection flag
- Clock generation
- I²C bus busy flag
- Arbitration Lost flag
- End of byte transmission flag
- Transmitter/Receiver flag
- Stop/Start generation

I²C Slave Features:

- Stop bit detection
- I²C bus busy flag
- Detection of misplaced start or stop condition
- Programmable I²C Address detection (both 7-bit and 10-bit mode)
- General Call address programmable
- Transfer problem detection
- End of byte transmission flag
- Transmitter/Receiver flag.

Interrupt Features:

- Interrupt generation on error condition, on transmission request and on data received
- Interrupt address vector for each interrupt source
- Pending bit and mask bit for each interrupt source
- Programmable interrupt priority respects the other peripherals of the microcontroller
- Interrupt address vector programmable

DMA Features:

- DMA both in transmission and in reception with enabling bits
- DMA from/toward both Register File and Memory
- End Of Block interrupt sources with the related pending bits

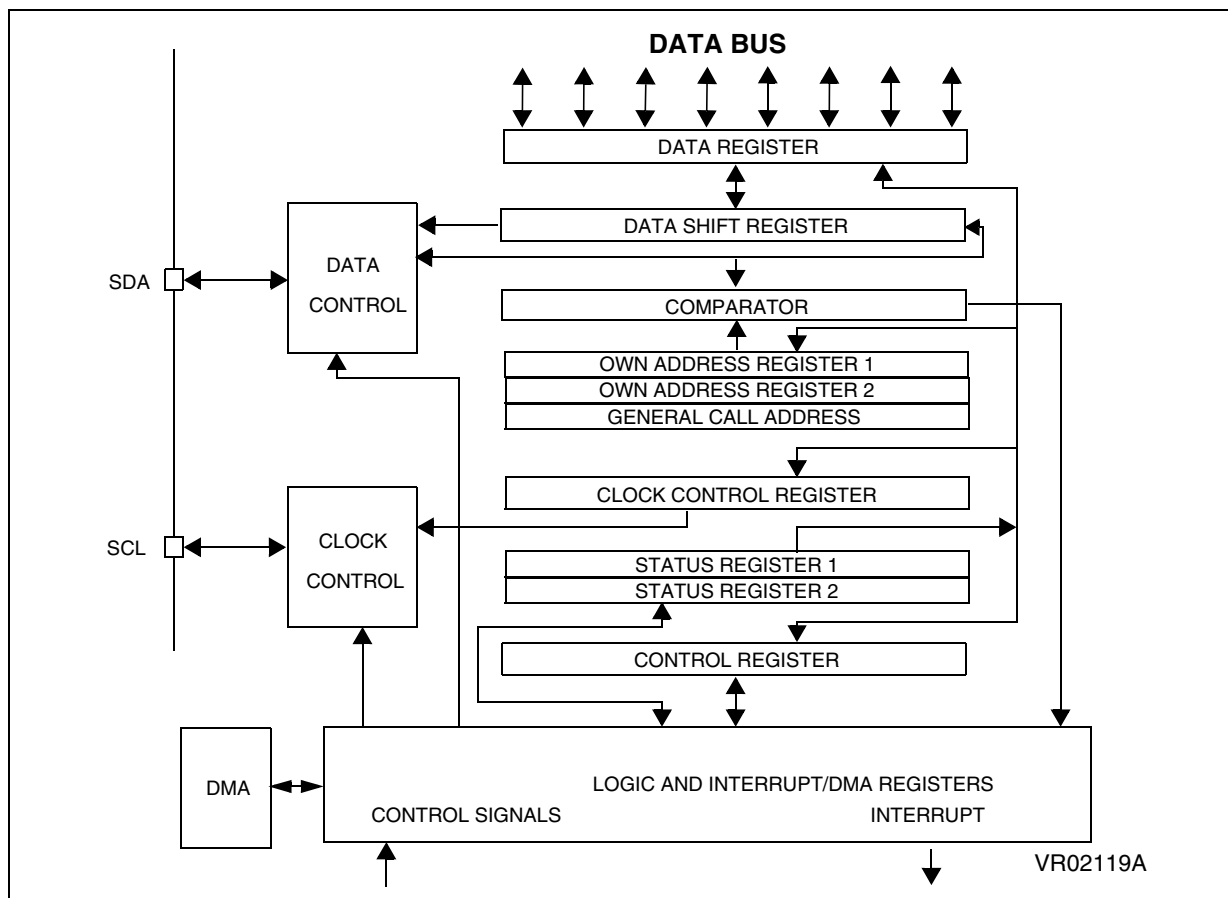
I²C BUS INTERFACE (Cont'd)Figure 126. I²C Interface Block Diagram

10.8.3 Functional Description

Refer to the I2CCR, I2CSR1 and I2CSR2 registers in [Section 10.8.7](#) for the bit definitions.

The I²C interface works as an I/O interface between the ST9 microcontroller and the I²C bus protocol. In addition to receiving and transmitting data, the interface converts data from serial to parallel format and vice versa using an interrupt or polled handshake.

It operates in Multimaster/slave I²C mode. The selection of the operating mode is made by software.

The I²C interface is connected to the I²C bus by a data pin (SDA) and a clock pin (SCL) which must be configured as open drain when the I²C cell is enabled by programming the I/O port bits and the PE bit in the I2CCR register. In this case, the value of the external pull-up resistance used depends on the application.

When the I²C cell is disabled, the SDA and SCL ports revert to being standard I/O port pins.

The I²C interface has sixteen internal registers.

Six of them are used for initialization:

- Own Address Registers I2COAR1, I2COAR2
- General Call Address Register I2CADR
- Clock Control Registers I2CCCR, I2CECCR
- Control register I2CCR

The following four registers are used during data transmission/reception:

- Data Register I2CDR
- Control Register I2CCR
- Status Register 1 I2CSR1
- Status Register 2 I2CSR2

I²C BUS INTERFACE (Cont'd)

The following seven registers are used to handle the interrupt and the DMA features:

- Interrupt Status Register I2CISR
- Interrupt Mask Register I2CIMR
- Interrupt Vector Register I2CIVR
- Receiver DMA Address Pointer Register I2CRDAP
- Receiver DMA Transaction Counter Register I2CRDC
- Transmitter DMA Address Pointer Register I2CTDAP
- Transmitter DMA transaction Counter Register I2CTDC

The interface can decode both addresses:

- Software programmable 7-bit General Call address
- I²C address stored by software in the I2COAR1 register in 7-bit address mode or stored in I2COAR1 and I2COAR2 registers in 10-bit address mode.

After a reset, the interface is disabled.

IMPORTANT:

1. To guarantee correct operation, before enabling the peripheral (while I2CCR.PE=0), configure bit7 and bit6 of the I2COAR2 register according to the internal clock INTCLK (for example 11xxxxxb in the range 14 - 30 MHz).

2. Bit7 of the I2CCR register must be cleared.

10.8.3.1 Mode Selection

In I²C mode, the interface can operate in the four following modes:

- Master transmitter/receiver
- Slave transmitter/receiver

By default, it operates in slave mode.

This interface automatically switches from slave to master after a start condition is generated on the bus and from master to slave in case of arbitration loss or stop condition generation.

In Master mode, it initiates a data transfer and generates the clock signal. A serial data transfer always begins with a start condition and ends with a stop condition. Both start and stop conditions are generated in master mode by software.

In Slave mode, it is able to recognize its own address (7 or 10-bit), as stored in the I2COAR1 and I2COAR2 registers and (when the I2CCR.ENG

bit is set) the General Call address (stored in I2CADR register). It never recognizes the Start Byte (address byte 01h) whatever its own address is.

Data and addresses are transferred in 8 bits, MSB first. The first byte(s) following the start condition contain the address (one byte in 7-bit mode, two bytes in 10-bit mode). The address is always transmitted in master mode.

A 9th clock pulse follows the 8 clock cycles of a byte transfer, during which the receiver must send an acknowledge bit to the transmitter. Acknowledge is enabled and disabled by software. Refer to [Figure 127](#).

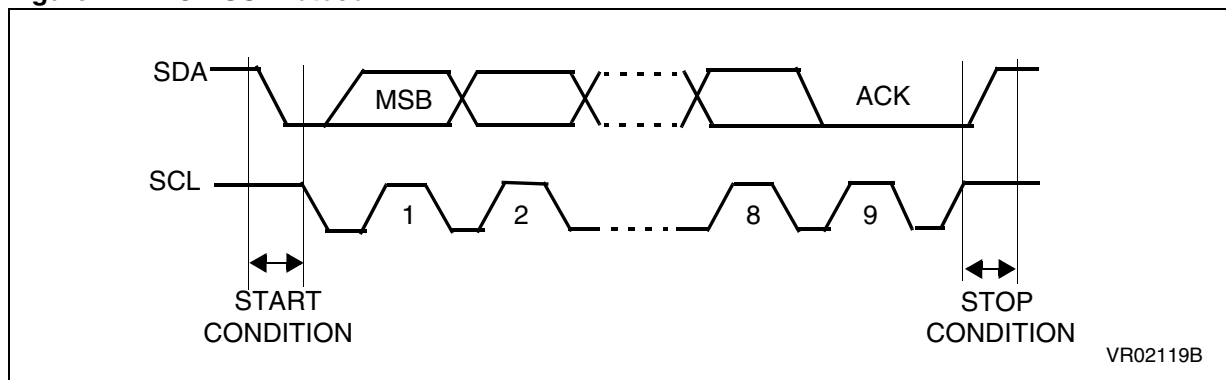
I²C BUS INTERFACE (Cont'd)Figure 127. I²C BUS Protocol

Any transfer can be done using either the I²C registers directly or via the DMA.

If the transfer is to be done directly by accessing the I2CDR, the interface waits (by holding the SCL line low) for software to write in the Data Register before transmission of a data byte, or to read the Data Register after a data byte is received.

If the transfer is to be done via DMA, the interface sends a request for a DMA transfer. Then it waits for the DMA to complete. The transfer between the interface and the I²C bus will begin on the next rising edge of the SCL clock.

The SCL frequency (F_{scl}) generated in master mode is controlled by a programmable clock divider. The speed of the I²C interface may be selected between Standard (0-100KHz) and Fast (100-400KHz) I²C modes.

10.8.4 I²C State Machine

To enable the interface in I²C mode the I2CCR.PE bit must be set **twice** as the first write only activates the interface (only the PE bit is set); and the bit7 of I2CCR register must be cleared.

The I²C interface always operates in slave mode (the M/SL bit is cleared) except when it initiates a transmission or a receipt sequencing (master mode).

The multimaster function is enabled with an automatic switch from master mode to slave mode when the interface loses the arbitration of the I²C bus.

10.8.4.1 I²C Slave Mode

As soon as a start condition is detected, the address word is received from the SDA line and sent to the shift register; then it is compared with the address of the interface or the General Call address (if selected by software).

Note: In 10-bit addressing mode, the comparison includes the header sequence (11110xx0) and the two most significant bits of the address.

- **Header (10-bit mode) or Address (both 10-bit and 7-bit modes) not matched:** the state machine is reset and waits for another Start condition.
- **Header matched (10-bit mode only):** the interface generates an acknowledge pulse if the ACK bit of the control register (I2CCR) is set.
- **Address matched:** the I2CSR1.ADSL bit is set and an acknowledge bit is sent to the master if the I2CCR.ACK bit is set. An interrupt request occurs if the I2CCR.ITE bit is set. Then the SCL line is held low until the microcontroller reads the I2CSR1 register (see [Figure 128](#) Transfer sequencing EV1).

I²C BUS INTERFACE (Cont'd)

Next, depending on the data direction bit (least significant bit of the address byte), and after the generation of an acknowledge, the slave must go in sending or receiving mode.

In 10-bit mode, after receiving the address sequence the slave is always in receive mode. It will enter transmit mode on receiving a repeated Start condition followed by the header sequence with matching address bits and the least significant bit set (11110xx1).

Slave Receiver

Following the address reception and after I2CSR1 register has been read, the slave receives bytes from the SDA line into the Shift Register and sends them to the I2CDR register. After each byte it generates an acknowledge bit if the I2CCR.ACK bit is set.

When the acknowledge bit is sent, the I2CSR1.BTF flag is set and an interrupt is generated if the I2CCR.ITE bit is set (see [Figure 128](#) Transfer sequencing EV2).

Then the interface waits for a read of the I2CSR1 register followed by a read of the I2CDR register, or waits for the DMA to complete.

Slave Transmitter

Following the address reception and after I2CSR1 register has been read, the slave sends bytes from the I2CDR register to the SDA line via the internal shift register.

When the acknowledge bit is received, the I2CCR.BTF flag is set and an interrupt is generated if the I2CCR.ITE bit is set (see [Figure 128](#) Transfer sequencing EV3).

The slave waits for a read of the I2CSR1 register followed by a write in the I2CDR register or waits for the DMA to complete, **both holding the SCL line low** (except on EV3-1).

Error Cases

- **BERR**: Detection of a Stop or a Start condition during a byte transfer.
The I2CSR2.BERR flag is set and an interrupt is generated if I2CCR.ITE bit is set.
If it is a stop then the state machine is reset.
If it is a start then the state machine is reset and it waits for the new slave address on the bus.

- **AF**: Detection of a no-acknowledge bit.
The I2CSR2.AF flag is set and an interrupt is generated if the I2CCR.ITE bit is set.

Note: In both cases, SCL line is not stretched low; however, the SDA line, due to possible «0» bits transmitted last, can remain low. It is then necessary to release both lines by software.

Other Events

- **ADSL**: Detection of a Start condition after an acknowledge time-slot.
The state machine is reset and starts a new process. The I2CSR1.ADSL flag bit is set and an interrupt is generated if the I2CCR.ITE bit is set.
The SCL line is stretched low.
- **STOPF**: Detection of a Stop condition after an acknowledge time-slot.
The state machine is reset. Then the I2CSR2.STOPF flag is set and an interrupt is generated if the I2CCR.ITE bit is set.

How to release the SDA / SCL lines

Check that the I2CSR1.BUSY bit is reset. Set and subsequently clear the I2CCR.STOP bit while the I2CSR1.BTF bit is set; then the SDA/SCL lines are released immediately after the transfer of the current byte.

This will also reset the state machine; any subsequent STOP bit (EV4) will **not** be detected.

10.8.4.2 I²C Master Mode

To switch from default Slave mode to Master mode a Start condition generation is needed.

Setting the I2CCR.START bit while the I2CSR1.BUSY bit is cleared causes the interface to generate a Start condition.

Once the Start condition is generated, the peripheral is in master mode (I2CSR1.M/SL=1) and I2CSR1.SB (Start bit) flag is set and an interrupt is generated if the I2CCR.ITE bit is set (see [Figure 128](#) Transfer sequencing EV5 event).

The interface waits for a read of the I2CSR1 register followed by a write in the I2CDR register with the Slave address, **holding the SCL line low**.

I²C BUS INTERFACE (Cont'd)

Then the slave address is sent to the SDA line. In 7-bit addressing mode, one address byte is sent.

In 10-bit addressing mode, sending the first byte including the header sequence causes the I2CSR1.EVF and I2CSR1.ADD10 bits to be set by hardware with interrupt generation if the I2CCR.ITE bit is set.

Then the master waits for a read of the I2CSR1 register followed by a write in the I2CDR register, **holding the SCL line low** (see Figure 128 Transfer sequencing EV9). Then the second address byte is sent by the interface.

After each address byte, an acknowledge clock pulse is sent to the SCL line if the I2CSR1.EVF and

- I2CSR1.ADD10 bit (if first header)
- I2CSR2.ADDTX bit (if address or second header)

are set, and an interrupt is generated if the I2CCR.ITE bit is set.

The peripheral waits for a read of the I2CSR1 register followed by a write into the Control Register (I2CCR) by holding the SCL line low (see Figure 128 Transfer sequencing EV6 event).

If there was no acknowledge (I2CSR2.AF=1), the master must stop or restart the communication (set the I2CCR.START or I2CCR.STOP bits).

If there was an acknowledge, the state machine enters a sending or receiving process according to the data direction bit (least significant bit of the address), the I2CSR1.BTF flag is set and an interrupt is generated if I2CCR.ITE bit is set (see Transfer sequencing EV7, EV8 events).

If the master loses the arbitration of the bus there is no acknowledge, the I2CSR2.AF flag is set and the master must set the START or STOP bit in the control register (I2CCR). The I2CSR2.ARLO flag is set, the I2CSR1.M/SL flag is cleared and the process is reset. An interrupt is generated if I2CCR.ITE is set.

Master Transmitter:

The master waits for the microcontroller to write in the Data Register (I2CDR) or it waits for the DMA to complete **both holding the SCL line low** (see Transfer sequencing EV8).

Then the byte is received into the shift register and sent to the SDA line. When the acknowledge bit is received, the I2CSR1.BTF flag is set and an interrupt is generated if the I2CCR.ITE bit is set or the DMA is requested.

Note: In 10-bit addressing mode, to switch the master to Receiver mode, software must generate a repeated Start condition and resend the header sequence with the least significant bit set (11110xx1).

Master Receiver:

The master receives a byte from the SDA line into the shift register and sends it to the I2CDR register. It generates an acknowledge bit if the I2CCR.ACK bit is set and an interrupt if the I2CCR.ITE bit is set or a DMA is requested (see Transfer sequencing EV7 event).

Then it waits for the microcontroller to read the Data Register (I2CDR) or waits for the DMA to complete **both holding SCL line low**.

Error Cases

- **BERR:** Detection of a Stop or a Start condition during a byte transfer.
The I2CSR2.BERR flag is set and an interrupt is generated if I2CCR.ITE is set.
- **AF:** Detection of a no acknowledge bit
The I2CSR2.AF flag is set and an interrupt is generated if I2CCR.ITE is set.
- **ARLO:** Arbitration Lost
The I2CSR2.ARLO flag is set, the I2CSR1.M/SL flag is cleared and the process is reset. An interrupt is generated if the I2CCR.ITE bit is set.

Note: In all cases, to resume communications, set the I2CCR.START or I2CCR.STOP bits.

Events generated by the I²C interface

- **STOP condition**
When the I2CCR.STOP bit is set, a Stop condition is generated **after the transfer** of the current byte, the I2CSR1.M/SL flag is cleared and the state machine is reset. No interrupt is generated in master mode at the detection of the stop condition.
- **START condition**
When the I2CCR.START bit is set, a start condition is generated as soon as the I²C bus is free. The I2CSR1.SB flag is set and an interrupt is generated if the I2CCR.ITE bit is set.

I²C BUS INTERFACE (Cont'd)

Figure 128. Transfer Sequencing

7-bit Slave receiver:

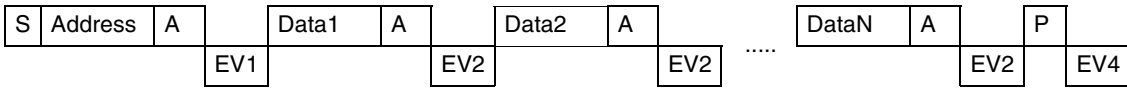

7-bit Slave transmitter:

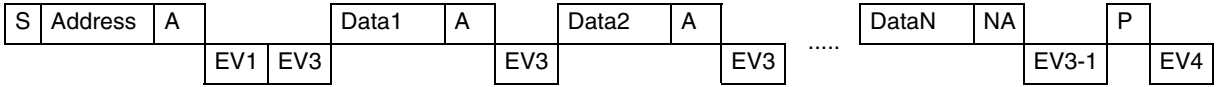

7-bit Master receiver:

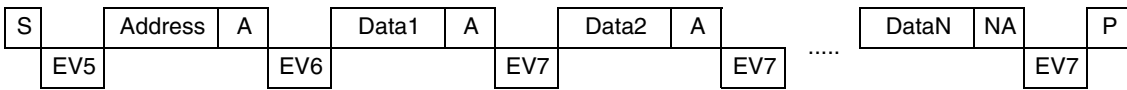

7-bit Master transmitter:

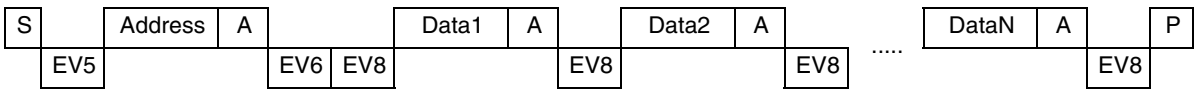

10-bit Slave receiver:

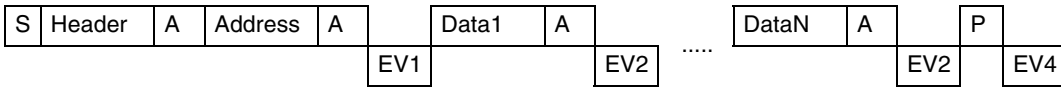

10-bit Slave transmitter:

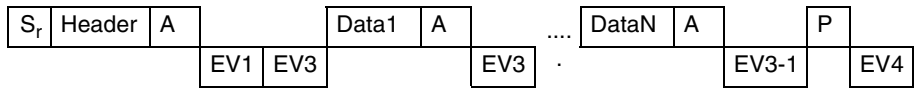

10-bit Master transmitter

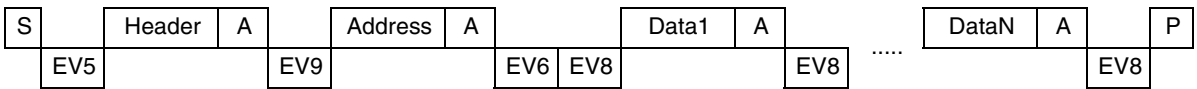

10-bit Master receiver:

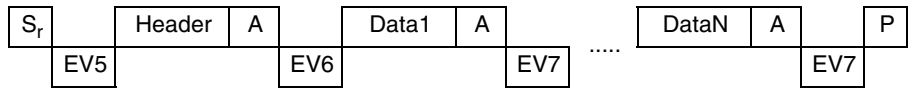

Legend:

S=Start, Sr = Repeated Start, P=Stop, A=Acknowledge, NA=Non-acknowledge, EVx=Event (with interrupt if ITE=1)

EV1: EVF=1, ADSL=1, cleared by reading SR1 register.

EV2: EVF=1, BTF=1, cleared by reading SR1 register followed by reading DR register or when DMA is complete.

EV3: EVF=1, BTF=1, cleared by reading SR1 register followed by writing DR register or when DMA is complete.

EV3-1: EVF=1, AF=1, BTF=1; AF is cleared by reading SR1 register, BTF is cleared by releasing the lines (STOP=1, STOP=0) or writing DR register (for example DR=FFh). **Note:** If lines are released by STOP=1, STOP=0 the subsequent EV4 is not seen.

EV4: EVF=1, STOPF=1, cleared by reading SR2 register.

- EV5:** EVF=1, SB=1, cleared by reading SR1 register followed by writing DR register.
- EV6:** EVF=1, ADDTX=1, cleared by reading SR1 register followed by writing CR register (for example PE=1).
- EV7:** EVF=1, BTF=1, cleared by reading SR1 register followed by reading DR register or when DMA is complete.
- EV8:** EVF=1, BTF=1, cleared by reading SR1 register followed by writing DR register or when DMA is complete.
- EV9:** EVF=1, ADD10=1, cleared by reading SR1 register followed by writing DR register.

Figure 129. Event Flags and Interrupt Generation

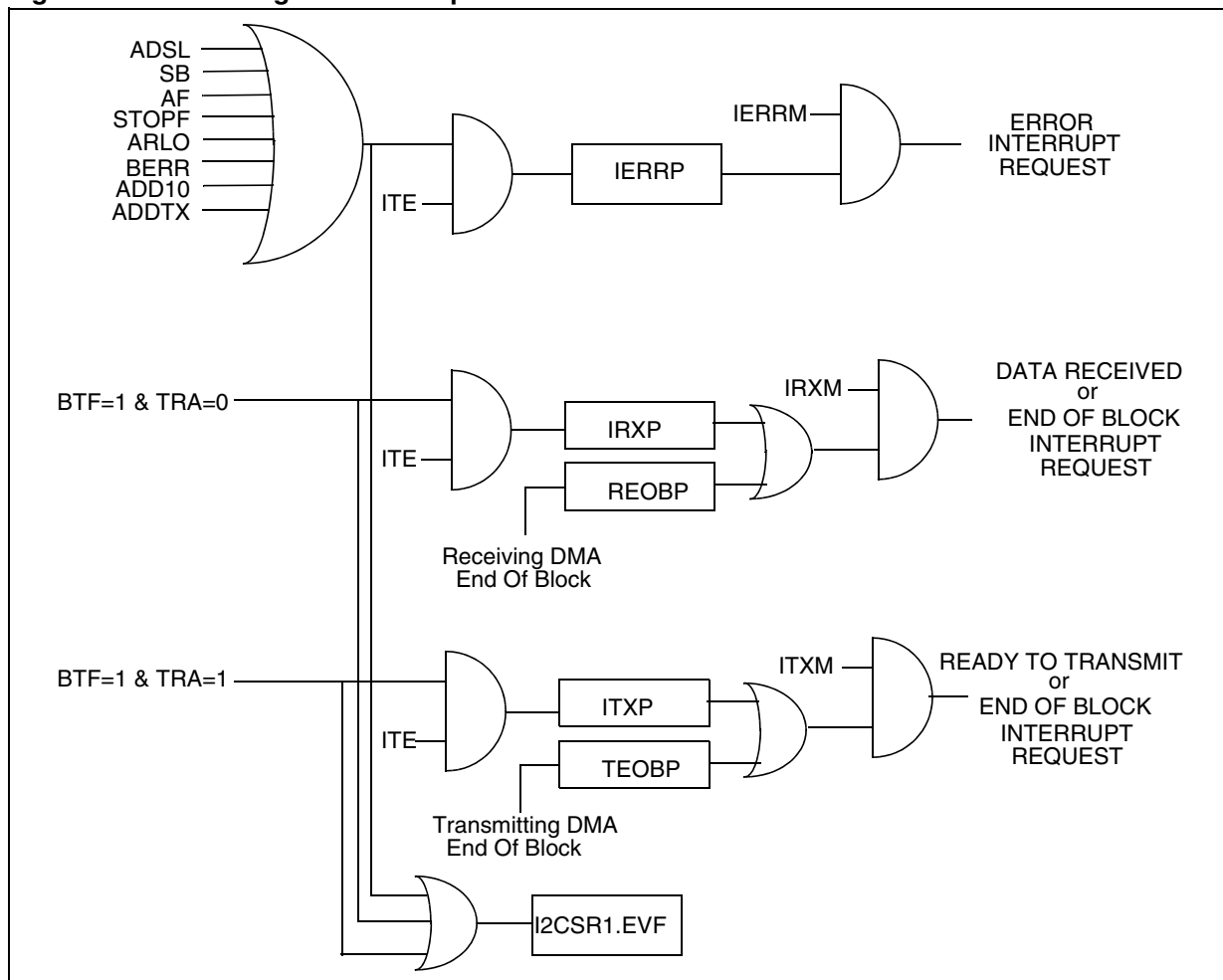

I²C BUS INTERFACE (Cont'd)

10.8.5 Interrupt Features

The I²Cbus interface has three interrupt sources related to “Error Condition”, “Peripheral Ready to Transmit” and “Data Received”.

The peripheral uses the ST9+ interrupt internal protocol without requiring the use of the external interrupt channel. Dedicated registers of the peripheral should be loaded with appropriate values to set the interrupt vector (see the description of the I2CIVR register), the interrupt mask bits (see the description of the I2CIMR register) and the interrupt priority and pending bits (see the description of the I2CISR register).

The peripheral also has a global interrupt enable (the I2CCR.ITE bit) that must be set to enable the interrupt features. Moreover there is a global interrupt flag (I2CSR1.EVF bit) which is set when one of the interrupt events occurs (except the End Of Block interrupts - see the DMA Features section).

The “Data Received” interrupt source occurs after the acknowledge of a received data byte is performed. It is generated when the I2CSR1.BTF flag is set and the I2CSR1.TRA flag is zero.

If the DMA feature is enabled in receiver mode, this interrupt is not generated and the same interrupt vector is used to send a Receiving End Of Block interrupt (See the DMA feature section).

The “Peripheral Ready To Transmit” interrupt source occurs as soon as a data byte can be transmitted by the peripheral. It is generated when the I2CSR1.BTF and the I2CSR1.TRA flags are set.

If the DMA feature is enabled in transmitter mode, this interrupt is not generated and the same interrupt vector is used to send a Transmitting End Of Block interrupt (See the DMA feature section).

The “Error condition” interrupt source occurs when one of the following condition occurs:

- Address matched in Slave mode while I2CCR.ACK=1 (I2CSR1.ADSL and I2CSR1.EVF flags = 1)
- Start condition generated (I2CSR1.SB and I2CSR1.EVF flags = 1)
- No acknowledge received after byte transmission (I2CSR2.AF and I2CSR1.EVF flags = 1)
- Stop detected in Slave mode

- (I2CSR2.STOPF and I2CSR1.EVF flags = 1)
- Arbitration lost in Master mode (I2CSR2.ARLO and I2CSR1.EVF flags = 1)
- Bus error, Start or Stop condition detected during data transfer (I2CSR2.BERR and I2CSR1.EVF flags = 1)
- Master has sent the header byte (I2CSR1.ADD10 and I2CSR1.EVF flags = 1)
- Address byte successfully transmitted in Master mode. (I2CSR1.EVF = 1 and I2CSR2.ADDTX=1)

Each interrupt source has a dedicated interrupt address pointer vector stored in the I2CIVR register. The five more significant bits of the vector address are programmable by the customer, whereas the three less significant bits are set by hardware depending on the interrupt source:

- 010: error condition detected
- 100: data received
- 110: peripheral ready to transmit

The priority with respect to the other peripherals is programmable by setting the PRL[2:0] bits in the I2CISR register. The lowest interrupt priority is obtained by setting all the bits (this priority level is never acknowledged by the CPU and is equivalent to disabling the interrupts of the peripheral); the highest interrupt priority is programmed by resetting all the bits. See the Interrupt and DMA chapters for more details.

The internal priority of the interrupt sources of the peripheral is fixed by hardware with the following order: “Error Condition” (highest priority), “Data Received”, “Peripheral Ready to Transmit”.

Note: The DMA has the highest priority over the interrupts; moreover the “Transmitting End Of Block” interrupt has the same priority as the “Peripheral Ready to Transmit” interrupt and the “Receiving End Of Block” interrupt has the same priority as the “Data received” interrupt.

Each of these three interrupt sources has a pending bit (IERRP, IRXP, ITXP) in the I2CISR register that is set by hardware when the corresponding interrupt event occurs. An interrupt request is performed only if the corresponding mask bit is set (IERRM, IRXM, ITXM) in the I2CIMR register and the peripheral has a proper priority level. The pending bit has to be reset by software.

I²C BUS INTERFACE (Cont'd)

Note: Until the pending bit is reset (while the corresponding mask bit is set), the peripheral processes an interrupt request. So, if at the end of an interrupt routine the pending bit is not reset, another interrupt request is performed.

Note: Before the end of the transmission and reception interrupt routines, the I2CSR1.BTF flag bit should be checked, to acknowledge any interrupt requests that occurred during the interrupt routine and to avoid masking subsequent interrupt requests.

Note: The “Error” event interrupt pending bit (I2CISR.IERRP) is forced high when the error event flags are set (ADD10, ADSL and SB flags of the I2CSR1 register; SCLF, ADSTX, AF, STOPF, ARLO and BERR flags of the I2CSR2 register).

Moreover the Transmitting End Of Block interrupt has the same priority as the “Peripheral Ready to Transmit” interrupt and the Receiving End Of Block interrupt has the same priority as the “Data received” interrupt.

10.8.6 DMA Features

The peripheral can use the ST9+ on-chip Direct Memory Access (DMA) channels to provide high-speed data transaction between the peripheral and contiguous locations of Register File, and Memory. The transactions can occur from and toward the peripheral. The maximum number of transactions that each DMA channel can perform is 222 if the register file is selected or 65536 if memory is selected. The control of the DMA features is performed using registers placed in the peripheral register page (I2CISR, I2CIMR, I2CRDAP, I2CRDC, I2CTDAP, I2CTDC).

Each DMA transfer consists of three operations:

- A load from/to the peripheral data register (I2CDR) to/from a location of Register File/Mem-

ory addressed through the DMA Address Register (or Register pair)

- A post-increment of the DMA Address Register (or Register pair)
- A post-decrement of the DMA transaction counter, which contains the number of transactions that have still to be performed.

The priority level of the DMA features of the I²C interface with respect to the other peripherals and the CPU is the same as programmed in the I2CISR register for the interrupt sources. In the internal priority level order of the peripheral, the “Error” interrupt sources have higher priority, followed by DMA, “Data received” and “Receiving End Of Block” interrupts, “Peripheral Ready to Transmit” and “Transmitting End Of Block”.

Refer to the Interrupt and DMA chapters for details on the priority levels.

The DMA features are enabled by setting the corresponding enabling bits (RXDM, TXDM) in the I2CIMR register. It is possible to select also the direction of the DMA transactions.

Once the DMA transfer is completed (the transaction counter reaches 0 value), an interrupt request to the CPU is generated. This kind of interrupt is called “End Of Block”. The peripheral sends two different “End Of Block” interrupts depending on the direction of the DMA (Receiving End Of Block - Transmitting End Of Block). These interrupt sources have dedicated interrupt pending bits in the I2CIMR register (REOBP, TEOBP) and they are mapped on the same interrupt vectors as respectively “Data Received” and “Peripheral Ready to Transmit” interrupt sources. The same correspondence exists about the internal priority between interrupts.

Note: The I2CCR.ITE bit has no effect on the End Of Block interrupts.

Moreover, the I2CSR1.EVF flag is not set by the End Of Block interrupts.

I²C BUS INTERFACE (Cont'd)

10.8.6.1 DMA between Peripheral and Register File

If the DMA transaction is made between the peripheral and the Register File, one register is required to hold the DMA Address and one to hold the DMA transaction counter.

These two registers must be located in the Register File:

- the DMA Address Register in the even addressed register,
- the DMA Transaction Counter in the following register (odd address).

They are pointed to by the DMA Transaction Counter Pointer Register (I2CRDC register in receiving, I2CTDC register in transmitting) located in the peripheral register page.

In order to select the DMA transaction with the Register File, the control bit I2CRDC.RF/MEM in receiving mode or I2CTDC.RF/MEM in transmitting mode must be set.

The transaction Counter Register must be initialized with the number of DMA transfers to perform and will be decremented after each transaction.

The DMA Address Register must be initialized with the starting address of the DMA table in the Register File, and it is increased after each transaction. These two registers must be located between addresses 00h and DFh of the Register File.

When the DMA occurs between Peripheral and Register File, the I2CTDAP register (in transmission) and the I2CRDAP one (in reception) are not used.

10.8.6.2 DMA between Peripheral and Memory Space

If the DMA transaction is made between the peripheral and Memory, a register pair is required to hold the DMA Address and another register pair to hold the DMA Transaction counter. These two pairs of registers must be located in the Register File. The DMA Address pair is pointed to by the DMA Address Pointer Register (I2CRDAP register in reception, I2CTDAP register in transmission) located in the peripheral register page; the DMA Transaction Counter pair is pointed to by the DMA Transaction Counter Pointer Register (I2CRDC register in reception, I2CTDC register in transmission) located in the peripheral register page.

In order to select the DMA transaction with the Memory Space, the control bit I2CRDC.RF/MEM in receiving mode or I2CTDC.RF/MEM in transmitting mode must be reset.

The Transaction Counter registers pair must be initialized with the number of DMA transfers to perform and will be decremented after each transaction. The DMA Address register pair must be initialized with the starting address of the DMA table in the Memory Space, and it is increased after each transaction. These two register pairs must be located between addresses 00h and DFh of the Register File.

10.8.6.3 DMA in Master Receive

To correctly manage the reception of the last byte when the DMA in Master Receive mode is used, the following sequence of operations must be performed:

1. The number of data bytes to be received must be set to the effective number of bytes minus one byte.
2. When the Receiving End Of Block condition occurs, the I2CCR.STOP bit must be set and the I2CCR.ACK bit must be reset.

The last byte of the reception sequence can be received either using interrupts/polling or using DMA. If the user wants to receive the last byte using DMA, the number of bytes to be received must be set to 1, and the DMA in reception must be re-enabled (IMR.RXDM bit set) to receive the last byte. Moreover the Receiving End Of Block interrupt service routine must be designed to recognize and manage the two different End Of Block situations (after the first sequence of data bytes and after the last data byte).

I²C BUS INTERFACE (Cont'd)

10.8.7 Register Description

IMPORTANT:

1. To guarantee correct operation, before enabling the peripheral (while I2CCR.PE=0), configure bit7 and bit6 of the I2COAR2 register according to the internal clock INTCLK (for example 11xxxxxb in the range 14 - 30 MHz).

2. Bit7 of the I2CCR register must be cleared.

I²C CONTROL REGISTER (I2CCR)

R240 - Read / Write

Register Page: 20 (I2C_0) or 22 (I2C_1)

Reset Value: 0000 0000 (00h)

7							0
0	0	PE	ENGC	START	ACK	STOP	ITE

Bit 7:6 = **Reserved**
Must be cleared

Bit 5 = **PE** *Peripheral Enable*.

This bit is set and cleared by software.

0: Peripheral disabled (reset value)

1: Master/Slave capability

Notes:

- When I2CCR.PE=0, all the bits of the I2CCR register and the I2CSR1-I2CSR2 registers except the STOP bit are reset. All outputs will be released while I2CCR.PE=0
- When I2CCR.PE=1, the corresponding I/O pins are selected by hardware as alternate functions (open drain).
- To enable the I²C interface, write the I2CCR register **TWICE** with I2CCR.PE=1 as the first write only activates the interface (only I2CCR.PE is set).
- When PE=1, the FREQ[2:0] and EN10BIT bits in the I2COAR2 and I2CADR registers cannot be written. The value of these bits can be changed only when PE=0.

Bit 4 = **ENGC** *General Call address enable*.

Setting this bit the peripheral works as a slave and the value stored in the I2CADR register is recognized as device address.

This bit is set and cleared by software. It is also cleared by hardware when the interface is disabled (I2CCR.PE=0).

0: The address stored in the I2CADR register is ignored (reset value)

1: The General Call address stored in the I2CADR register will be acknowledged

Note: The correct value (usually 00h) must be written in the I2CADR register before enabling the General Call feature.

Bit 3 = **START** *Generation of a Start condition*.

This bit is set and cleared by software. It is also cleared by hardware when the interface is disabled (I2CCR.PE=0) or when the Start condition is sent (with interrupt generation if ITE=1).

– In master mode:

0: No start generation

1: Repeated start generation

– In slave mode:

0: No start generation (reset value)

1: Start generation when the bus is free

Bit 2 = **ACK** *Acknowledge enable*.

This bit is set and cleared by software. It is also cleared by hardware when the interface is disabled (I2CCR.PE=0).

0: No acknowledge returned (reset value)

1: Acknowledge returned after an address byte or a data byte is received

Bit 1 = **STOP** *Generation of a Stop condition*.

This bit is set and cleared by software. It is also cleared by hardware in master mode. It is not cleared when the interface is disabled (I2CCR.PE=0). In slave mode, this bit must be set only when I2CSR1.BTF=1.

– In master mode:

0: No stop generation

1: Stop generation after the current byte transfer or after the current Start condition is sent. The STOP bit is cleared by hardware when the Stop condition is sent.

– In slave mode:

0: No stop generation (reset value)

1: Release SCL and SDA lines after the current byte transfer (I2CSR1.BTF=1). In this mode the STOP bit has to be cleared by software.

I²C BUS INTERFACE (Cont'd)

Bit 0 = **ITE** *Interrupt Enable*.

The ITE bit enables the generation of interrupts. This bit is set and cleared by software and cleared by hardware when the interface is disabled (I2CCR.PE=0).

0: Interrupts disabled (reset value)

1: Interrupts enabled after any of the following conditions:

- Byte received or to be transmitted (I2CSR1.BTF and I2CSR1.EVF flags = 1)
- Address matched in Slave mode while I2CCR.ACK=1 (I2CSR1.ADSL and I2CSR1.EVF flags = 1)
- Start condition generated (I2CSR1.SB and I2CSR1.EVF flags = 1)
- No acknowledge received after byte transmission (I2CSR2.AF and I2CSR1.EVF flags = 1)
- Stop detected in Slave mode (I2CSR2.STOPF and I2CSR1.EVF flags = 1)
- Arbitration lost in Master mode (I2CSR2.ARLO and I2CSR1.EVF flags = 1)
- Bus error, Start or Stop condition detected during data transfer (I2CSR2.BERR and I2CSR1.EVF flags = 1)
- Master has sent header byte (I2CSR1.ADD10 and I2CSR1.EVF flags = 1)
- Address byte successfully transmitted in Master mode. (I2CSR1.EVF = 1 and I2CSR2.ADDTX = 1)

SCL is held low when the ADDTX flag of the I2CSR2 register or the ADD10, SB, BTF or ADSL flags of I2CSR1 register are set (See [Figure 128](#)) or when the DMA is not complete.

The transfer is suspended in all cases except when the BTF bit is set and the DMA is enabled. In this case the event routine must suspend the DMA transfer if it is required.

I²C STATUS REGISTER 1 (I2CSR1)

R241 - Read Only

Register Page: 20 (I2C_0) or 22 (I2C_1)

Reset Value: 0000 0000 (00h)

7							0
EVF	ADD10	TRA	BUSY	BTF	ADSL	M/SL	SB

Note: Some bits of this register are reset by a read operation of the register. Care must be taken when using instructions that work on single bit. Some of them perform a read of all the bits of the register before modifying or testing the wanted bit. So other bits of the register could be affected by the operation.

In the same way, the test/compare operations perform a read operation.

Moreover, if some interrupt events occur while the register is read, the corresponding flags are set, and correctly read, but if the read operation resets the flags, no interrupt request occurs.

Bit 7 = **EVF** *Event Flag*.

This bit is set by hardware as soon as an event (listed below or described in [Figure 128](#)) occurs. It is cleared by software when all event conditions that set the flag are cleared. It is also cleared by hardware when the interface is disabled (I2CCR.PE=0).

0: No event

1: One of the following events has occurred:

- Byte received or to be transmitted (I2CSR1.BTF and I2CSR1.EVF flags = 1)
- Address matched in Slave mode while I2CCR.ACK=1 (I2CSR1.ADSL and I2CSR1.EVF flags = 1)
- Start condition generated (I2CSR1.SB and I2CSR1.EVF flags = 1)
- No acknowledge received after byte transmission (I2CSR2.AF and I2CSR1.EVF flags = 1)
- Stop detected in Slave mode (I2CSR2.STOPF and I2CSR1.EVF flags = 1)
- Arbitration lost in Master mode (I2CSR2.ARLO and I2CSR1.EVF flags = 1)
- Bus error, Start or Stop condition detected during data transfer (I2CSR2.BERR and I2CSR1.EVF flags = 1)
- Master has sent header byte (I2CSR1.ADD10 and I2CSR1.EVF flags = 1)

I²C BUS INTERFACE (Cont'd)

- Address byte successfully transmitted in Master mode.
(I2CSR1.EVF = 1 and I2CSR2.ADDTX=1)

Bit 6 = ADD10 *10-bit addressing in Master mode.*
This bit is set when the master has sent the first byte in 10-bit address mode. An interrupt is generated if ITE=1.

It is cleared by software reading I2CSR1 register followed by a write in the I2CDR register of the second address byte. It is also cleared by hardware when peripheral is disabled (I2CCR.PE=0) or when the STOPF bit is set.

0: No ADD10 event occurred.

1: Master has sent first address byte (header).

Bit 5 = TRA *Transmitter/ Receiver.*

When BTF flag of this register is set and also TRA=1, then a data byte has to be transmitted. It is cleared automatically when BTF is cleared. It is also cleared by hardware after the STOPF flag of I2CSR2 register is set, loss of bus arbitration (ARLO flag of I2CSR2 register is set) or when the interface is disabled (I2CCR.PE=0).

0: A data byte is received (if I2CSR1.BTF=1)

1: A data byte can be transmitted (if I2CSR1.BTF=1)

Bit 4 = BUSY *Bus Busy.*

It indicates a communication in progress on the bus. The detection of the communications is always active (even if the peripheral is disabled).

This bit is set by hardware on detection of a Start condition and cleared by hardware on detection of a Stop condition. This information is still updated when the interface is disabled (I2CCR.PE=0).

0: No communication on the bus

1: Communication ongoing on the bus

Bit 3 = BTF *Byte Transfer Finished.*

This bit is set by hardware as soon as a byte is correctly received or before the transmission of a data byte with interrupt generation if ITE=1. It is cleared by software reading I2CSR1 register followed by a read or write of I2CDR register or when DMA is complete. It is also cleared by hardware when the interface is disabled (I2CCR.PE=0).

– Following a byte transmission, this bit is set after reception of the acknowledge clock pulse. BTF is cleared by reading I2CSR1 register followed by writing the next byte in I2CDR register or when DMA is complete.

– Following a byte reception, this bit is set after transmission of the acknowledge clock pulse if ACK=1. BTF is cleared by reading I2CSR1 register followed by reading the byte from I2CDR register or when DMA is complete.

The SCL line is held low while I2CSR1.BTF=1.

0: Byte transfer not done

1: Byte transfer succeeded

Bit 2 = ADSL *Address matched (Slave mode).*

This bit is set by hardware if the received slave address matches the I2COAR1/I2COAR2 register content or a General Call address. An interrupt is generated if ITE=1. It is cleared by software reading I2CSR1 register or by hardware when the interface is disabled (I2CCR.PE=0). The SCL line is held low while ADSL=1.

0: Address mismatched or not received

1: Received address matched

Bit 1 = M/SL *Master/Slave.*

This bit is set by hardware as soon as the interface is in Master mode (Start condition generated on the lines after the I2CCR.START bit is set). It is cleared by hardware after detecting a Stop condition on the bus or a loss of arbitration (ARLO=1). It is also cleared when the interface is disabled (I2CCR.PE=0).

0: Slave mode

1: Master mode

Bit 0 = SB *Start Bit (Master mode).*

This bit is set by hardware as soon as the Start condition is generated (following a write of START=1 if the bus is free). An interrupt is generated if ITE=1. It is cleared by software reading I2CSR1 register followed by writing the address byte in I2CDR register. It is also cleared by hardware when the interface is disabled (I2CCR.PE=0).

The SCL line is held low while SB=1.

0: No Start condition

1: Start condition generated

I²C BUS INTERFACE (Cont'd)

I²C STATUS REGISTER 2 (I2CSR2)

R242 - Read Only

Register Page: 20 (I2C_0) or 22 (I2C_1)

Reset Value: 0000 0000 (00h)

7							0
0	0	ADDTX	AF	STOPF	ARLO	BERR	GCAL

Note: Some bits of this register are reset by a read operation of the register. Care must be taken when using instructions that work on single bit. Some of them perform a read of all the bits of the register before modifying or testing the wanted bit. So other bits of the register could be affected by the operation.

In the same way, the test/compare operations perform a read operation.

Moreover, if some interrupt events occur while the register is read, the corresponding flags are set, and correctly read, but if the read operation resets the flags, no interrupt request occurs.

Bits 7:6 = Reserved. Forced to 0 by hardware.

Bit 5 = **ADDTX** Address or 2nd header transmitted in Master mode.

This bit is set by hardware when the peripheral, enabled in Master mode, has received the acknowledge relative to:

- Address byte in 7-bit mode
 - Address or 2nd header byte in 10-bit mode.
- 0: No address or 2nd header byte transmitted
1: Address or 2nd header byte transmitted.

Bit 4 = **AF** Acknowledge Failure.

This bit is set by hardware when no acknowledge is returned. An interrupt is generated if ITE=1.

It is cleared by software reading I2CSR2 register **after the falling edge of the acknowledge SCL pulse**, or by hardware when the interface is disabled (I2CCR.PE=0).

The SCL line is not held low while AF=1.

- 0: No acknowledge failure detected
1: A data or address byte was not acknowledged

Bit 3 = **STOPF** Stop Detection (Slave mode).

This bit is set by hardware when a Stop condition is detected on the bus after an acknowledge. An interrupt is generated if ITE=1.

It is cleared by software reading I2CSR2 register or by hardware when the interface is disabled (I2CCR.PE=0).

The SCL line is not held low while STOPF=1.

- 0: No Stop condition detected
1: Stop condition detected (**while slave receiver**)

Bit 2 = **ARLO** Arbitration Lost.

This bit is set by hardware when the interface (in master mode) loses the arbitration of the bus to another master. An interrupt is generated if ITE=1.

It is cleared by software reading I2CSR2 register or by hardware when the interface is disabled (I2CCR.PE=0).

After an ARLO event the interface switches back automatically to Slave mode (M/SL=0).

The SCL line is not held low while ARLO=1.

- 0: No arbitration lost detected
1: Arbitration lost detected

Bit 1 = **BERR** Bus Error.

This bit is set by hardware when the interface detects a Start or Stop condition during a byte transfer. An interrupt is generated if ITE=1.

It is cleared by software reading I2CSR2 register or by hardware when the interface is disabled (I2CCR.PE=0).

The SCL line is not held low while BERR=1.

Note: If a misplaced start condition is detected, also the **ARLO** flag is set; moreover, if a misplaced stop condition is placed on the acknowledge SCL pulse, also the **AF** flag is set.

- 0: No Start or Stop condition detected during byte transfer
1: Start or Stop condition detected during byte transfer

Bit 0 = **GCAL** General Call address matched.

This bit is set by hardware after an address matches with the value stored in the I2CADR register while ENGCG=1. In the I2CADR the General Call address must be placed before enabling the peripheral.

It is cleared by hardware after the detection of a Stop condition, or when the peripheral is disabled (I2CCR.PE=0).

- 0: No match
1: General Call address matched.

I²C BUS INTERFACE (Cont'd)**I²C CLOCK CONTROL REGISTER (I2CCCR)**

R243 - Read / Write

Register Page: 20 (I2C_0) or 22 (I2C_1)

Reset Value: 0000 0000 (00h)

7							0
FM/SM	CC6	CC5	CC4	CC3	CC2	CC1	CC0

Bit 7 = **FM/SM** *Fast/Standard I²C mode*.

This bit is used to select between fast and standard mode. See the description of the following bits. It is set and cleared by software. It is not cleared when the peripheral is disabled (I2CCR.PE=0)

Bits 6:0 = **CC[6:0]** *9-bit divider programming*

Implementation of a programmable clock divider. These bits and the CC[8:7] bits of the I2CECCR register select the speed of the bus (F_{SCL}) depending on the I²C mode. They are not cleared when the interface is disabled (I2CCR.PE=0).

Refer to the Electrical Characteristics section for the table of values ([Table 70 on page 399](#)).

Note: The programmed frequency is available with no load on SCL and SDA pins.

I²C OWN ADDRESS REGISTER 1 (I2COAR1)

R244 - Read / Write

Register Page: 20 (I2C_0) or 22 (I2C_1)

Reset Value: 0000 0000 (00h)

7							0
ADD7	ADD6	ADD5	ADD4	ADD3	ADD2	ADD1	ADD0

7-bit Addressing ModeBits 7:1 = **ADD[7:1]** *Interface address*.

These bits define the I²C bus address of the interface.

They are not cleared when the interface is disabled (I2CCR.PE=0).

Bit 0 = **ADD0** *Address direction bit*.

This bit is don't care; the interface acknowledges either 0 or 1.

It is not cleared when the interface is disabled (I2CCR.PE=0).

Note: Address 01h is always ignored.

10-bit Addressing ModeBits 7:0 = **ADD[7:0]** *Interface address*.

These are the least significant bits of the I²Cbus address of the interface.

They are not cleared when the interface is disabled (I2CCR.PE=0).

I²C BUS INTERFACE (Cont'd)

I²C OWN ADDRESS REGISTER 2 (I2COAR2)

R245 - Read / Write

Register Page: 20 (I2C_0) or 22 (I2C_1)

Reset Value: 0000 0000 (00h)

7							0
FREQ1	FREQ0	EN10BIT	FREQ2	0	ADD9	ADD8	0

Bits 7:6,4 = **FREQ[2:0]** *Frequency bits.*

IMPORTANT: To guarantee correct operation, set these bits before enabling the interface (while I2CCR.PE=0).

These bits can be set only when the interface is disabled (I2CCR.PE=0). To configure the interface to I²C specified delays, select the value corresponding to the microcontroller internal frequency INTCLK.

INTCLK Range (MHz)	FREQ2	FREQ1	FREQ0
2.5 - 6	0	0	0
6 - 10	0	0	1
10 - 14	0	1	0
14 - 24	0	1	1

Note: If an incorrect value, with respect to the MCU internal frequency, is written in these bits, the timings of the peripheral will not meet the I²C bus standard requirements.

Note: The FREQ[2:0] = 100, 101, 110, 111 configurations must not be used.

Bit 5 = **EN10BIT** *Enable 10-bit I²Cbus mode.*
When this bit is set, the 10-bit I²Cbus mode is enabled.

This bit can be written only when the peripheral is disabled (I2CCR.PE=0).

0: 7-bit mode selected
1: 10-bit mode selected

Bits 4:3 = Reserved.

Bits 2:1 = **ADD[9:8]** *Interface address.*
These are the most significant bits of the I²Cbus address of the interface (10-bit mode only). They

are not cleared when the interface is disabled (I2CCR.PE=0).

Bit 0 = Reserved.

I²C DATA REGISTER (I2CDR)

R246 - Read / Write

Register Page: 20 (I2C_0) or 22 (I2C_1)

Reset Value: 0000 0000 (00h)

7							0
DR7	DR6	DR5	DR4	DR3	DR2	DR1	DR0

Bits 7:0 = **DR[7:0]** *I2C Data.*

– In transmitter mode:

I2CDR contains the next byte of data to be transmitted. The byte transmission begins after the microcontroller has written in I2CDR or on the next rising edge of the clock if DMA is complete.

– In receiver mode:

I2CDR contains the last byte of data received. The next byte receipt begins after the I2CDR read by the microcontroller or on the next rising edge of the clock if DMA is complete.

GENERAL CALL ADDRESS (I2CADR)

R247 - Read / Write

Register Page: 20 (I2C_0) or 22 (I2C_1)

Reset Value: 1010 0000 (A0h)

7							0
ADR7	ADR6	ADR5	ADR4	ADR3	ADR2	ADR1	ADR0

Bits 7:0 = **ADR[7:0]** *Interface address.*

These bits define the I²Cbus General Call address of the interface. It must be written with the correct value depending on the use of the peripheral. If the peripheral is used in I²C bus mode, the 00h value must be loaded as General Call address.

The customer could load the register with other values.

The bits can be written only when the peripheral is disabled (I2CCR.PE=0)

The ADR0 bit is don't care; the interface acknowledges either 0 or 1.

Note: Address 01h is always ignored.

I²C BUS INTERFACE (Cont'd)**INTERRUPT STATUS REGISTER (I2CISR)**

R248 - Read / Write

Register Page: 20 (I2C_0) or 22 (I2C_1)

Reset Value: 1xxx xxxx (xxh)

7							0
1	PRL2	PRL1	PRL0	0	IERRP	IRXP	ITXP

Bit 7 = Reserved.

Must be kept at 1Bits 6:4 = **PRL[2:0]** *Interrupt/DMA Priority Bits.*

The priority is encoded with these three bits. The value of "0" has the highest priority, the value "7" has no priority. After the setting of this priority level, the priorities between the different Interrupt/DMA sources is hardware defined according with the following scheme:

- Error condition Interrupt (If DMASTOP=1) (Highest priority)
- Receiver DMA request
- Transmitter DMA request
- Error Condition Interrupt (If DMASTOP=0)
- Data Received/Receiver End Of Block
- Peripheral Ready To Transmit/Transmitter End Of Block (Lowest priority)

Bit 3 = Reserved.

Must be cleared.Bit 2 = **IERRP** *Error Condition pending bit*

0: No error

1: Error event detected (if ITE=1)

Note: The Interrupt pending bits can be reset by writing a "0" but is not possible to write a "1". It is mandatory to clear the interrupt source by writing a "0" in the pending bit when executing the interrupt service routine. When serving an interrupt routine, the user should reset **ONLY** the pending bit related to the served interrupt routine (and not reset the other pending bits).

To detect the specific error condition that occurred, the flag bits of the I2CSR1 and I2CSR2 register should be checked.

Note: The IERRP pending bit is forced high when the error event flags are set (ADSL and SB flags in the I2CSR1 register, SCLF, ADDTX, AF, STOPF, ARLO and BERR flags in the I2CSR2 register). If at least one flag is set, the application code should not reset the IERRP bit.

Bit 1 = **IRXP** *Data Received pending bit*

0: No data received

1: data received (if ITE=1).

Bit 0 = **ITXP** *Peripheral Ready To Transmit pending bit*

0: Peripheral not ready to transmit

1: Peripheral ready to transmit a data byte (if ITE=1).

I²C BUS INTERFACE (Cont'd)

INTERRUPT VECTOR REGISTER (I2CIVR)

R249 - Read / Write

Register Page: 20 (I2C_0) or 22 (I2C_1)

Reset Value: Undefined

7							0
V7	V6	V5	V4	V3	EV2	EV1	0

Bits 7:3 = **V[7:3]** *Interrupt Vector Base Address*. User programmable interrupt vector bits. These are the five more significant bits of the interrupt vector base address. They must be set before enabling the interrupt features.

Bits 2:1 = **EV[2:1]** *Encoded Interrupt Source*. These Read-Only bits are set by hardware according to the interrupt source:

- 01: error condition detected
- 10: data received
- 11: peripheral ready to transmit

Bit 0 = Reserved.
Forced by hardware to 0.

RECEIVER DMA SOURCE ADDRESS POINTER REGISTER (I2CRDAP)

R250 - Read / Write

Register Page: 20 (I2C_0) or 22 (I2C_1)

Reset Value: Undefined

7							0
RA7	RA6	RA5	RA4	RA3	RA2	RA1	RPS

Bits 7:1 = **RA[7:1]** *Receiver DMA Address Pointer*. I2CRDAP contains the address of the pointer (in the Register File) of the Receiver DMA data source when the DMA is selected between the peripheral and the Memory Space. Otherwise,

(DMA between peripheral and Register file), this register has no meaning. See [Section 10.8.6.1](#) for more details on the use of this register.

Bit 0 = **RPS** *Receiver DMA Memory Pointer Selector*.

If memory has been selected for DMA transfer (I2CRDC.RF/MEM = 0) then:

- 0: Select ISR register for Receiver DMA transfer address extension.
- 1: Select DMASR register for Receiver DMA transfer address extension.

RECEIVER DMA TRANSACTION COUNTER REGISTER (I2CRDC)

R251 - Read / Write

Register Page: 20 (I2C_0) or 22 (I2C_1)

Reset Value: Undefined

7							0
RC7	RC6	RC5	RC4	RC3	RC2	RC1	RF/MEM

Bits 7:1 = **RC[7:1]** *Receiver DMA Counter Pointer*. I2CRDC contains the address of the pointer (in the Register File) of the DMA receiver transaction counter when the DMA between Peripheral and Memory Space is selected. Otherwise (DMA between Peripheral and Register File), this register points to a pair of registers that are used as DMA Address register and DMA Transaction Counter. See [Section 10.8.6.1](#) and [Section 10.8.6.2](#) for more details on the use of this register.

Bit 0 = **RF/MEM** *Receiver Register File/ Memory Selector*.

- 0: DMA towards Memory
- 1: DMA towards Register file

I²C BUS INTERFACE (Cont'd)**TRANSMITTER DMA SOURCE ADDRESS POINTER REGISTER (I2CTDAP)**

R252 - Read / Write

Register Page: 20 (I2C_0) or 22 (I2C_1)

Reset Value: Undefined

7							0
TA7	TA6	TA5	TA4	TA3	TA2	TA1	TPS

Bits 7:1 = **TA[7:1]** *Transmit DMA Address Pointer*. I2CTDAP contains the address of the pointer (in the Register File) of the Transmitter DMA data source when the DMA between the peripheral and the Memory Space is selected. Otherwise (DMA between the peripheral and Register file), this register has no meaning.

See [Section 10.8.6.2](#) for more details on the use of this register.

Bit 0 = **TPS** *Transmitter DMA Memory Pointer Selector*.

If memory has been selected for DMA transfer (I2CTDC.RF/MEM = 0) then:

- 0: Select ISR register for transmitter DMA transfer address extension.
- 1: Select DMASR register for transmitter DMA transfer address extension.

TRANSMITTER DMA TRANSACTION COUNTER REGISTER (I2CTDC)

R253 - Read / Write

Register Page: 20 (I2C_0) or 22 (I2C_1)

Reset Value: Undefined

7							0
TC7	TC6	TC5	TC4	TC3	TC2	TC1	RF/MEM

Bits 7:1 = **TC[7:1]** *Transmit DMA Counter Pointer*. I2CTDC contains the address of the pointer (in the Register File) of the DMA transmitter transaction counter when the DMA between Peripheral and Memory Space is selected. Otherwise, if the DMA between Peripheral and Register File is selected, this register points to a pair of registers that are used as DMA Address register and DMA Transaction Counter.

See [Section 10.8.6.1](#) and [Section 10.8.6.2](#) for more details on the use of this register.

Bit 0 = **RF/MEM** *Transmitter Register File/ Memory Selector*.

- 0: DMA from Memory
- 1: DMA from Register file

EXTENDED CLOCK CONTROL REGISTER (I2CECCR)

R254 - Read / Write

Register Page: 20 (I2C_0) or 22 (I2C_1)

Reset Value: 0000 0000 (00h)

7							0
0	0	0	0	0	0	CC8	CC7

Bits 7:2 = Reserved. Must always be cleared.

Bits 1:0 = **CC[8:7]** *9-bit divider programming*
Implementation of a programmable clock divider. These bits and the CC[6:0] bits of the I2CCCR register select the speed of the bus (F_{SCL}). For a description of the use of these bits, see the I2CCCR register. They are not cleared when the interface is disabled (I2CCCR.PE=0).

I²C BUS INTERFACE (Cont'd)

INTERRUPT MASK REGISTER (I2CIMR)

R255 - Read / Write

Register Page: 20 (I2C_0) or 22 (I2C_1)

Reset Value: 00xx 0000 (x0h)

7							0
RXDM	TXDM	REOBP	TEOBP	0	IERRM	IRXM	ITXM

Bit 7 = **RXDM Receiver DMA Mask.**

0: DMA reception disable.

1: DMA reception enable

RXDM is reset by hardware when the transaction counter value decrements to zero, that is when a Receiver End Of Block interrupt is issued.

Bit 6 = **TXDM Transmitter DMA Mask.**

0: DMA transmission disable.

1: DMA transmission enable.

TXDM is reset by hardware when the transaction counter value decrements to zero, that is when a Transmitter End Of Block interrupt is issued.

Bit 5 = **REOBP Receiver DMA End Of Block Flag.**

REOBP should be reset by software in order to avoid undesired interrupt routines, especially in initialization routine (after reset) and after entering the End Of Block interrupt routine. Writing "0" in this bit will cancel the interrupt request

Note: REOBP can only be written to "0".

0: End of block not reached.

1: End of data block in DMA receiver detected

Bit 4 = **TEOBP Transmitter DMA End Of Block**

TEOBP should be reset by software in order to avoid undesired interrupt routines, especially in initialization routine (after reset) and after entering the End Of Block interrupt routine. Writing "0" will cancel the

interrupt request.

Note: TEOBP can only be written to "0".

0: End of block not reached

1: End of data block in DMA transmitter detected.

Bit 3 = Reserved. This bit **must** be cleared.

Bit 2 = **IERRM Error Condition interrupt mask bit.**

This bit enables/ disables the Error interrupt.

0: Error interrupt disabled.

1: Error Interrupt enabled.

Bit 1 = **IRXM Data Received interrupt mask bit.**

This bit enables/ disables the Data Received and Receive DMA End of Block interrupts.

0: Interrupts disabled

1: Interrupts enabled

Note: This bit has no effect on DMA transfer

Bit 0 = **ITXM Peripheral Ready To Transmit interrupt mask bit.**

This bit enables/ disables the Peripheral Ready To Transmit and Transmit DMA End of Block interrupts.

0: Interrupts disabled

1: Interrupts enabled

Note: This bit has no effect on DMA transfer.

I²C BUS INTERFACE (Cont'd)Table 51. I²C BUS Register Map and Reset Values

Address (Hex.)	Register Name	7	6	5	4	3	2	1	0
F0h	I2CCR Reset Value	- 0	- 0	PE 0	ENGC 0	START 0	ACK 0	STOP 0	ITE 0
F1h	I2CSR1 Reset Value	EVF 0	ADD10 0	TRA 0	BUSY 0	BTF 0	ADSL 0	M/SL 0	SB 0
F2h	I2CSR2 Reset Value	- 0	0 0	ADDTX 0	AF 0	STOPF 0	ARLO 0	BERR 0	GCAL 0
F3h	I2CCCR Reset Value	FM/SM 0	CC6 0	CC5 0	CC4 0	CC3 0	CC2 0	CC1 0	CC0 0
F4h	I2COAR1 Reset Value	ADD7 0	ADD6 0	ADD5 0	ADD4 0	ADD3 0	ADD2 0	ADD1 0	ADD0 0
F5h	I2COAR2 Reset Value	FREQ1 0	FREQ0 0	EN10BIT 0	FREQ2 0	0 0	ADD9 0	ADD8 0	0 0
F6h	I2CDR Reset Value	DR7 0	DR6 0	DR5 0	DR4 0	DR3 0	DR2 0	DR1 0	DR0 0
F7h	I2CADR Reset Value	ADR7 1	ADR6 0	ADR5 1	ADR4 0	ADR3 0	ADR2 0	ADR1 0	ADR0 0
F8h	I2CISR Reset Value	DMASTOP 1	PRL2 X	PRL1 X	PRL0 X	X	IERRP X	IRXP X	ITXP X
F9h	I2CIVR Reset Value	V7 X	V6 X	V5 X	V4 X	V3 X	EV2 X	EV1 X	0 0
FAh	I2CRDAP Reset Value	RA7 X	RA6 X	RA5 X	RA4 X	RA3 X	RA2 X	RA1 X	RPS X
FBh	I2CRDC Reset Value	RC7 X	RC6 X	RC5 X	RC4 X	RC3 X	RC2 X	RC1 X	RF/MEM X
FCh	I2CTDAP Reset Value	TA7 X	TA6 X	TA5 X	TA4 X	TA3 X	TA2 X	TA1 X	TPS X
FDh	I2CTDC Reset Value	TC7 X	TC6 X	TC5 X	TC4 X	TC3 X	TC2 X	TC1 X	RF/MEM X
FEh	I2CECCR	0 0	0 0	0 0	0 0	0 0	0 0	CC8 0	CC7 0
FFh	I2CIMR Reset Value	RXDM 0	TXDM 0	REOBP X	TEOBP X	0	IERRM 0	IRXM 0	ITXM 0

10.8.8 IMPORTANT NOTES ON I2C

Please refer to [Section 13.3 on page 411](#)

10.9 J1850 Byte Level Protocol Decoder (JBLPD)

10.9.1 Introduction

The JBLPD is used to exchange data between the ST9 microcontroller and an external J1850 transceiver I.C.

The JBLPD transmits a string of variable pulse width (VPW) symbols to the transceiver. It also receives VPW encoded symbols from the transceiver, decodes them and places the data in a register.

In-frame responses of type 0, 1, 2 and 3 are supported and the appropriate normalization bit is generated automatically. The JBLPD filters out any incoming messages which it does not care to receive. It also includes a programmable external loop delay.

The JBLPD uses two signals to communicate with the transceiver:

- VPWI (input)
- VPWO (output)

10.9.2 Main Features

- SAE J1850 compatible
- Digital filter
- In-Frame Responses of type 0, 1, 2, 3 supported with automatic normalization bit
- Programmable External Loop Delay
- Diagnostic 4x time mode
- Diagnostic Local Loopback mode
- Wide range of MCU internal frequencies allowed
- Low power consumption mode (JBLPD suspended)
- Very low power consumption mode (JBLPD disabled)
- Don't care message filter
- Selectable VPWI input polarity
- Selectable Normalization Bit symbol form
- 6 maskable interrupts
- DMA transmission and reception with End Of Block interrupts

J1850 BYTE LEVEL PROTOCOL DECODER (Cont'd)

Figure 130. JBLPD Byte Level Protocol Decoder Block Diagram

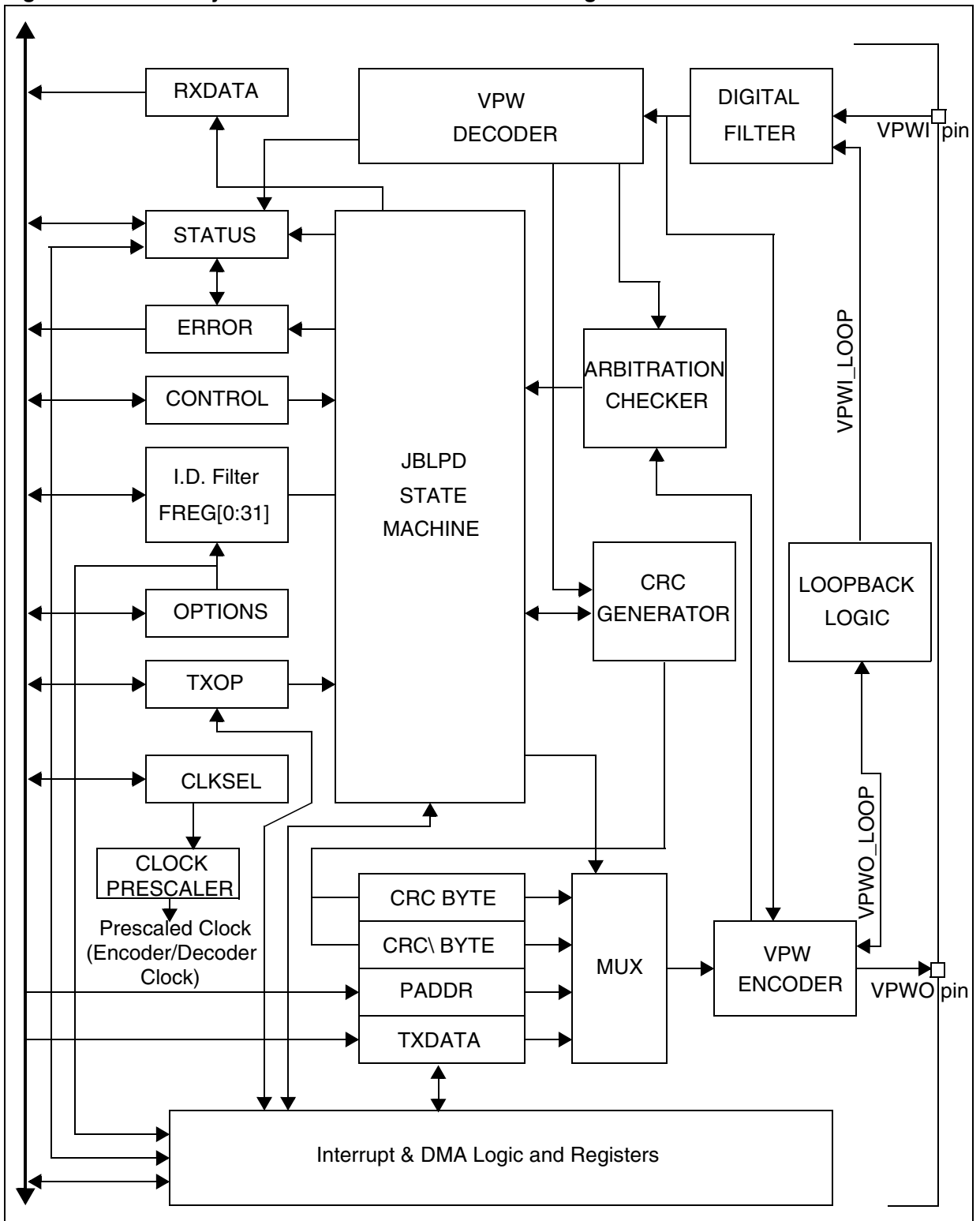

J1850 BYTE LEVEL PROTOCOL DECODER (Cont'd)

10.9.3 Functional Description

10.9.3.1 J1850 protocol symbols

J1850 symbols are defined as a duration (in microseconds or clock cycles) and a state which can be either an active state (logic high level on VPWO) or a passive state (logic low level on VPWO).

An idle J1850 bus is in a passive state.

Any symbol begins by changing the state of the VPW line. The line is in this state for a specific duration depending on the symbol being transmitted.

Durations, and hence symbols, are measured as time between successive state transitions. Each symbol has only one level transition of a specific duration.

Symbols for logic zero and one data bits can be either a high or a low level, but all other symbols are defined at only one level.

Each symbol is placed directly next to another. Therefore, every level transition means that another symbol has begun.

Data bits of a logic zero are either a short duration if in a passive state or a long duration if in an active state. Data bits of a logic one are either a long duration if in a passive state or a short duration if in an active state. This ensures that data logic zeros predominate during bus arbitration.

An eight bit data byte transmission will always have eight transitions. For all data byte and CRC byte transfers, the first bit is a passive state and the last bit is an active state.

For the duration of the VPW, symbols are expressed in terms of Tv's (or VPW mode timing values). J1850 symbols and Tv values are described in the SAE J1850 specification, in [Table 52](#) and in [Table 53](#).

An ignored Tv I.D. occurs for level transitions which occur in less than the minimum time required for an invalid bit detect. The VPW encoder does not recognize these characters as they are filtered out by the digital filter. The VPW decoder does not resynchronize its counter with either edge of "ignored" pulses. Therefore, the counter which times symbols continues to time from the last transition which occurred after a valid symbol (including the invalid bit symbol) was recognized.

A symbol recognized as an invalid bit will resynchronize the VPW decoder to the invalid bit edges.

In the case of the reception of an invalid bit, the JBLPD peripheral will set the IBD bit in the ERROR register. The JBLPD peripheral shall terminate any transmissions in progress, and disable receive transfers and RDRF flags until the VPW decoder recognizes a valid EOF symbol from the bus.

The JBLPD's state machine handles all the Tv I.D.s in accordance with the SAE J1850 specification.

Note: Depending on the value of a control bit, the polarity of the VPWI input can be the same as the J1850 bus or inverted with respect to it.

Table 52. J1850 Symbol definitions

Symbol	Definition
Data Bit Zero	Passive for Tv1 or Active for Tv2
Data Bit One	Passive for Tv2 or Active for Tv1
Start of Frame (SOF)	Active for Tv3
End of Data (EOD)	Passive for Tv3
End of Frame (EOF)	Passive for Tv4
Inter Frame Separation (IFS)	Passive for Tv6
IDLE Bus Condition (IDLE)	Passive for > Tv6
Normalization Bit (NB)	Active for Tv1 or Tv2
Break (BRK)	Active for Tv5

Table 53. J1850 VPW Mode Timing Value (Tv) definitions (in clock cycles)

Pulse Width or Tv I.D.	Minimum Duration	Nominal Duration	Maximum Duration
Ignored	0	N/A	<=7
Invalid Bit	>7	N/A	<=34
Tv1	>34	64	<=96
Tv2	>96	128	<=163
Tv3	>163	200	<=239
Tv4	>239	280	N/A
Tv5	>239	300	N/A
Tv6	>280	300	N/A

J1850 BYTE LEVEL PROTOCOL DECODER (Cont'd)

10.9.3.2 Transmitting Messages

This section describes the general procedures used by the JBLPD to successfully transmit J1850 frames of data out the VPWO pin. The first five sub-sections describe the procedures used for transmitting the specific transmit data types. The last section goes into the details of the transmitted symbol timing, synchronizing of symbols received from the external J1850 bus, and how data bit arbitration works.

The important concept to note for transmitting data is: the activity sent over the VPWO line should be timed with respect to the levels and transitions seen on the filtered VPWI line.

The J1850 bus is a multiplexed bus, and the VPWO & VPWI pins interface to this bus through a transceiver I.C. Therefore, the propagation delay through the transceiver I.C. and external bus filtering must be taken into account when looking for transmitted edges to appear back at the receiver. The external propagation delay for an edge sent out on the VPWO line, to be detected on the VPWI line is denoted as T_{p-ext} and is programmable between 0 and 31 μs nominal via the JDLY[4:0] bits in CONTROL register.

The transmitter VPW encoder sets the proper level to be sent out the VPWO line. It then waits for the corresponding level transition to be reflected back at the VPW decoder input.

Taking into account the external loop delay (T_{p-ext}) and the digital filter delay, the encoder will time its output to remain at this level so that the received symbol is at the correct nominal symbol time (refer to "Transmit Opcode Queuing" section). If arbitration is lost at any time during bit 0 or bit 1 transmission, then the VPWO line goes passive. At the end of the symbol time on VPWO, the encoder changes the state of VPWO if any more information is to be transmitted. It then times the new state change from the receiver decoder output.

Note that depending on the symbol (especially the SOF, NB0, NB1 symbols) the decoder output may actually change to the desired state before the transmit is attempted. It is important to still syn-

chronize off the decoder output to time the VPWO symbol time.

A detailed description of the JBLPD opcodes can be found in the description of the OP[2:0] bits in the TXOP register.

Message Byte String Transmission (Type 0 IFR)

Message byte transmitting is the outputting of data bytes on the VPWO pin that occurs subsequent to a received bus idle condition. All message byte strings start with a SOF symbol transmission, then one or more data bytes are transmitted. A CRC byte is then transmitted followed by an EOD symbol (see [Figure 131](#)) to complete the transmission. If transmission is queued while another frame is being received, then the JBLPD will time an Inter-Frame Separation (IFS) time ($Tv6$) before commencing with the SOF character.

The user program will decide at some point that it wants to initiate a message byte string. The user program writes the TXDATA register with the first message data byte to be transmitted. Next, the TXOP register is written with the MSG opcode if more than one data byte is contained within the message, or with MSG+CRC opcode if one data byte is to be transmitted. The action of writing the TXOP register causes the TRDY bit to be cleared signifying that the TXDATA register is full and a corresponding opcode has been queued. The JBLPD must wait for an EOF nominal time period at which time data is transferred from the TXDATA register to the transmit shift register. The TRDY bit is again set since the TXDATA register is empty.

The JBLPD should also begin transmission if another device begins transmitting early. As long as an EOF minimum time period elapses, the JBLPD should begin timing and asserting the SOF symbol with the intention of arbitrating for the bus during the transmission of the first data byte. If a transmit is requested during an incoming SOF symbol, the JBLPD should be able to synchronize itself to the incoming SOF up to a time of $Tv1$ max. (96 μs) into the SOF symbol before declaring that it was too late to arbitrate for this frame.

J1850 BYTE LEVEL PROTOCOL DECODER (Cont'd)

If the J1850 bus was IDLE at the time the first data byte and opcode are written, the transmitter will immediately transfer data from the TXDATA register to the transmit shift register. The TRDY bit will once again be set signifying the readiness to accept a new data byte. The second data byte can then be written followed by the respective opcode. In the case of the last data byte, the TXOP register should be written with the MSG+CRC opcode. The transmitter will transmit the internally generated CRC after the last bit of the data byte. Once the TRDY bit is set signifying the acceptance of the last data byte, the first byte of the next message can be queued by writing the TXDATA register followed by a TXOP register write. The block will wait until the current data and the CRC data byte are sent out and a new IFS has expired before transmitting the new data. This is the case even if IFR data reception takes place in the interim.

Lost arbitration any time during the transfer of type 0 data will be honoured by immediately relinquishing control to the higher priority message. The TLA bit in the STATUS register is set accordingly and an interrupt will be generated assuming the TLA_M bit in the IMR register is set. It is responsibility of the user program to re-send the message beginning with the first byte if desired. This may be done at any time by rewriting only the TXOP register if the TXDATA contents have not changed.

Any transmitted data and CRC bytes during the transmit frame will also be received and transferred to the RXDATA register if the corresponding message filter bit is set in the FREG[0:31] registers. If the corresponding bit is not set in FREG[0:31], then the transmitted data is also not transferred to RXDATA. Also, the RDRF will not get set during frame and receive events such as RDOF & EODM.

NOTE: The correct procedure for transmitting is to write first the TXDATA register and then the TXOP

register except during DMA transfers (see [Section 10.9.6.4 DMA Management in Transmission Mode](#)).

Transmitting a Type 1 IFR

The user program will decide to transmit an IFR type 1 byte in response to a message which is currently being received (See [Figure 132](#)). It does so by writing the IFR1 opcode to the TXOP register. Transmitting IFR data type 1 requires only a single write of the TXOP register with the IFR1 opcode set. The MLC[3:0] bits should be set to the proper "byte-received-count-required-before-IFR'ing" value. If no error conditions (IBD, IFD, TRA, RBRK or CRCE) exist to prevent transmission, the JBLPD peripheral will then transmit out the contents of the PADDR register at the next EOD nominal time period or at a time greater than the EOD minimum time period if a falling edge is detected on filtered J1850 bus line signifying another transmitter is beginning early. The NB1 symbol precedes the PADDR register value and is followed with an EOF delimiter. The TRDY flag is cleared on the write of the TXOP register. The TRDY bit is set once the NB1 begins transmitting.

Although the JBLPD should never lose arbitration for data in the IFR portion of a type 1 frame, higher priority messages are always honoured under the rules of arbitration. If arbitration is lost then the VPWO line is set to the passive state. The TLA bit in the STATUS register is set accordingly and an interrupt will be generated if enabled. The IFR1 is not retried. It is lost if the JBLPD peripheral loses arbitration. Also, the data that made it out on the bus will be received in the RXDATA register if not put into sleep mode. Note that for the transmitter to synchronize to the incoming signals of a frame, an IFR should be queued before an EODM is received for the present frame.

J1850 BYTE LEVEL PROTOCOL DECODER (Cont'd)**Transmitting a Type 2 IFR**

The user program will decide to transmit an IFR type 2 byte in response to a message which is currently being received (See [Figure 133](#)). It does so by writing the IFR2 opcode to the TXOP register. Transmitting IFR data type 2 requires only a single write of the TXOP register with the IFR2 opcode set. The MLC[3:0] bits can also be set to check for message length errors. If no error conditions (IBD, IFD, TRA, RBRK or CRCE) exist to prevent transmission, the JBLPD will transmit out the contents of the PADDR register at the next EOD nominal time period or after an EOD minimum time period if a rising edge is detected on the filtered VPWI line signifying another transmitter beginning early. The NB1 symbol precedes the PADDR register value and is followed with an EOF delimiter. The TRDY flag will be cleared on the write of the TXOP register. The TRDY bit is set once the NB1 begins transmitting.

Lost arbitration for this case is a normal occurrence since type 2 IFR data is made up of single bytes from multiple responders. If arbitration is lost the VPWO line is released and the JBLPD waits until the byte on the VPWI line is completed. Note that the IFR that did make it out on the bus will be received in the RXDATA register if it is not put into sleep mode. Then, the JBLPD re-attempts to send its physical address immediately after the end of the last byte. The TLA bit is not set if arbitration is lost and the user program does not need to re-queue data or an opcode. The JBLPD will re-attempt to send its PADDR register contents until it successfully does so or the 12-byte frame maximum is reached if NFL=0. If NFL=1, then re-attempts to send an IFR2 are executed until cancelled by the CANCEL opcode or a JBLPD disable. Note that for the transmitter to synchronize to the incoming signals of a frame, an IFR should be queued before an EODM is received for the present frame.

Transmitting a Type 3 IFR Data String

The user program will decide to transmit an IFR type 3 byte string in response to a message which

is currently being received (See [Figure 134](#)). It does so by writing the IFR3 or IFR3+CRC opcode to the TXOP register. Transmitting IFR data type 3 is similar to transmitting a message, in that the TXDATA register is written with the first data byte followed by a TXOP register write. For a single data byte IFR3 transmission, the TXOP register would be written with IFR3+CRC opcode set. The MLC[3:0] bits can also be set to a proper value to check for message length errors before enabling the IFR transmit.

If no error conditions (IBD, IFD, TRA, RBRK or CRCE) exist to prevent transmission, the JBLPD will wait for an EOD nominal time period on the filtered VPWI line (or for at least an EOD minimum time followed by a rising edge signifying another transmitter beginning early) at which time data is transferred from the TXDATA register to the transmit shift register. The TRDY bit is set since the TXDATA register is empty. A NB0 symbol is output on the VPWO line followed by the data byte and possibly the CRC byte if a IFR3+CRC opcode was set. Once the first IFR3 byte has been successfully transmitted, successive IFR3 bytes are sent with TXDATA/TXOP write sequences where the MLC[3:0] bits are don't cares. The final byte in the IFR3 string must be transmitted with the IFR3+CRC opcode to trigger the JBLPD to append the CRC byte to the string. The user program may queue up the next message opcode sequence once the TRDY bit has been set.

Although arbitration should never be lost for data in the IFR portion of a type 3 frame, higher priority messages are always honoured under the rules of arbitration. If arbitration is lost then the block should relinquish the bus by taking the VPWO line to the passive state. In this case the TLA bit in the STATUS register is set, and an interrupt will be generated if enabled. Note also, that the IFR data that did make it out on the bus will be received in the RXDATA register if not in sleep mode. Note that for the transmitter to synchronize to the incoming signals of a frame, an IFR should be queued before an EODM is received for the current frame.

J1850 BYTE LEVEL PROTOCOL DECODER (Cont'd)

Figure 131. J1850 String Transmission Type 0

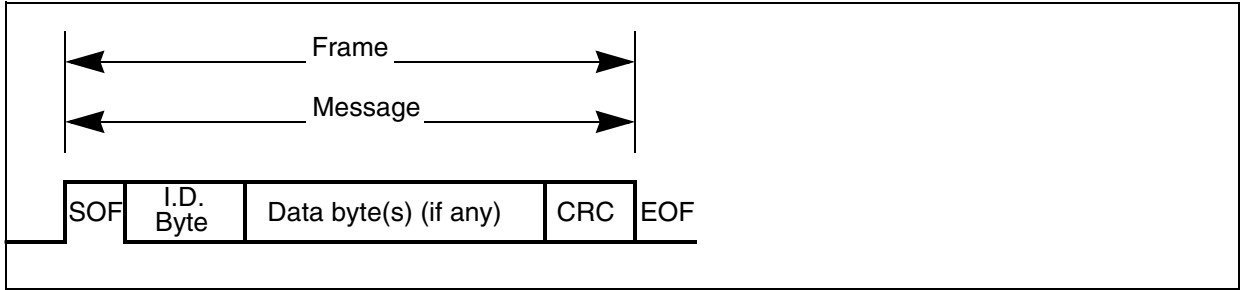

Figure 132. J1850 String Transmission Type 1

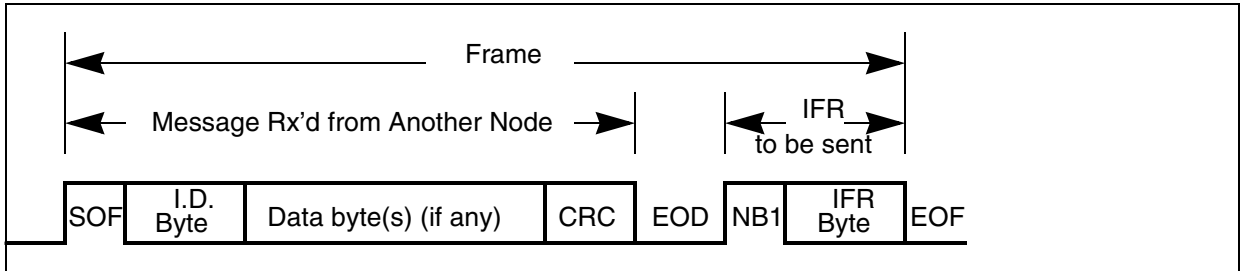

Figure 133. J1850 String Transmission Type 2

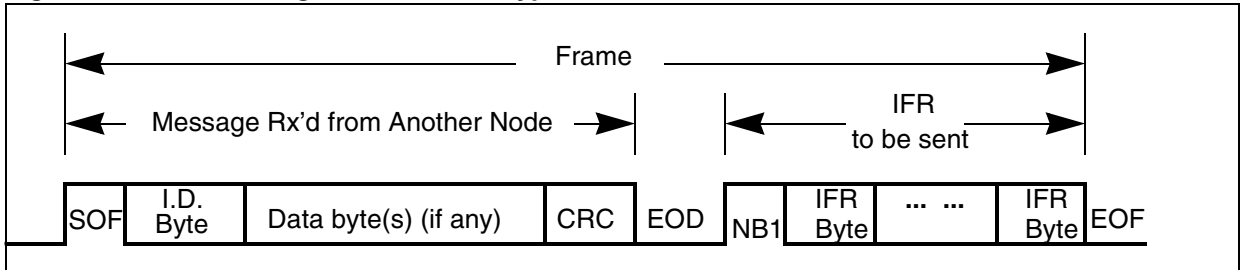
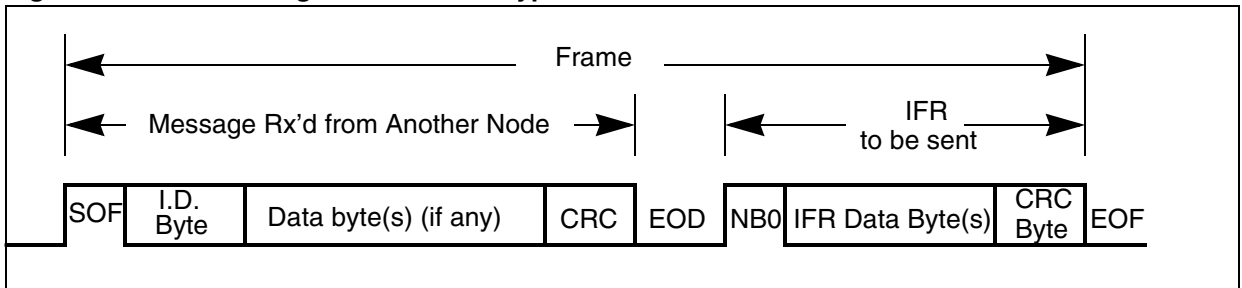

Figure 134. J1850 String Transmission Type 3



J1850 BYTE LEVEL PROTOCOL DECODER (Cont'd)

Transmit Opcode Queuing

The JBLPD has the capability of queuing opcode transmits written to the TXOP register until J1850 bus conditions are in a correct state for the transmit to occur. For example, a MSGx opcode can be queued when the JBLPD is presently receiving a frame (or transmitting a MSG+CRC opcode) or an IFRx opcode can be queued when currently receiving or transmitting the message portion of a frame.

Queuing a MSG or MSG+CRC opcode for the next frame can occur while another frame is in progress. A MSGx opcode is written to the TXOP register when the present frame is past the point where arbitration for control of the bus for this frame can occur. The JBLPD will wait for a nominal IFS symbol (or EOFmin if another node begins early) to appear on the VPWI line before commencing to transmit this queued opcode. The TRDY bit for the queued opcode will remain clear until the EOFmin is detected on the VPWI line where it will then get set. Queued MSGx transmits for the next frame do not get cancelled for TLA, IBD, IFD or CRCE errors that occur in the present frame. An RBRK error will cancel a queued opcode for the next frame.

Queuing an IFRx opcode for the present frame can occur at any time after the detection of the beginning of an SOF character from the VPWI line. The queued IFR will wait for a nominal EOD symbol (or EODmin if another node begins early) before commencing to transmit the IFR. A queued IFR transmit will be cancelled on IBD, IFD, CRCE, RBRK errors as well as on a correct message length check error or frame length limit violation if these checks are enabled.

Transmit Bus Timing, Arbitration, and Synchronization

The external J1850 bus on the other side of the transceiver I.C. is a single wire multiplex bus with multiple nodes transmitting a number of different types of message frames. Each node can transmit at any time and synchronization and arbitration is used to determine who wins control of the transmit. It is the obligation of the JBLPD transmitter section to synchronize off of symbols on the bus, and to place only nominal symbol times onto the bus within the accuracy of the peripheral (+/- 1 µs).

To transmit proper symbols the JBLPD must know what is going on out on the bus. Fortunately, the

JBLPD has a receiver pin which tells the transmitter about bus activity. Due to characteristics of the J1850 bus and the eight-clock digital filter, the signals presented to the VPW symbol decoder are delayed a certain amount of time behind the actual J1850 bus. Also, due to wave shaping and other signal conditioning of the transceiver I.C. the actions of the VPWO pin on the transmitter take time to appear on the bus itself. The total external J1850 bus delays are defined in the SAE J1850 standard as nominally 16 µs. The nominal 16 µs loop delay will actually vary between different transceiver I.C.'s. The JBLPD peripheral thus includes a programmability of the external loop delay in the bit positions JDLY[4:0]. This assures only nominal transmit symbols are placed on the bus by the JBLPD.

The method of transmitting for the JBLPD includes interaction between the transmitter and the receiver. The transmitter starts a symbol by placing the proper level (active or passive) on its VPWO pin. The transmitter then waits for the corresponding pin transition (inverted, of course) at the VPW decoder input. Note that the level may actually appear at the input before the transmitter places the value on the VPWO pin. Timing of the remainder of the symbol starts when the transition is detected. Refer to [Figure 136](#), Case 1. The symbol timeout value is defined as:

$$\text{SymbolTimeout} = \text{NominalSymbolTime} - \text{ExternalLoopDelay} - 8 \mu\text{s}$$

$$\begin{aligned} \text{NominalSymbolTime} &= T_v \text{ Symbol time} \\ \text{ExternalLoopDelay} &= \text{defined via JDLY}[4:0] \\ 8 \mu\text{s} &= \text{Digital Filter} \end{aligned}$$

Bit-by-bit arbitration must be used to settle the conflicts that occur when multiple nodes attempt to transmit frames simultaneously. Arbitration is applied to each data bit symbol transmitted starting after the SOF or NBx symbol and continuing until the EOD symbol. During simultaneous transmissions of active and passive states on the bus, the resultant state on the bus is the active state. If the JBLPD detects a received symbol from the bus that is different from the symbol being transmitted, then the JBLPD will discontinue its transmit operation prior to the start of the next bit. Once arbitration has been lost, the VPWO pin must go passive within one period of the prescaled clock of the peripheral. [Figure 135](#) shows 3 nodes attempting to arbitrate for the bus with Node B eventually winning with the highest priority data.

J1850 BYTE LEVEL PROTOCOL DECODER (Cont'd)

Figure 135. J1850 Arbitration Example

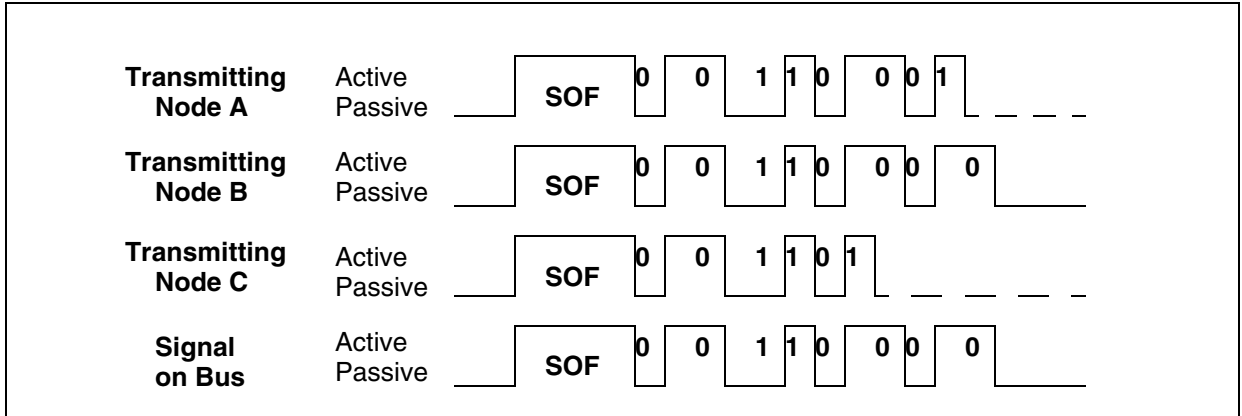
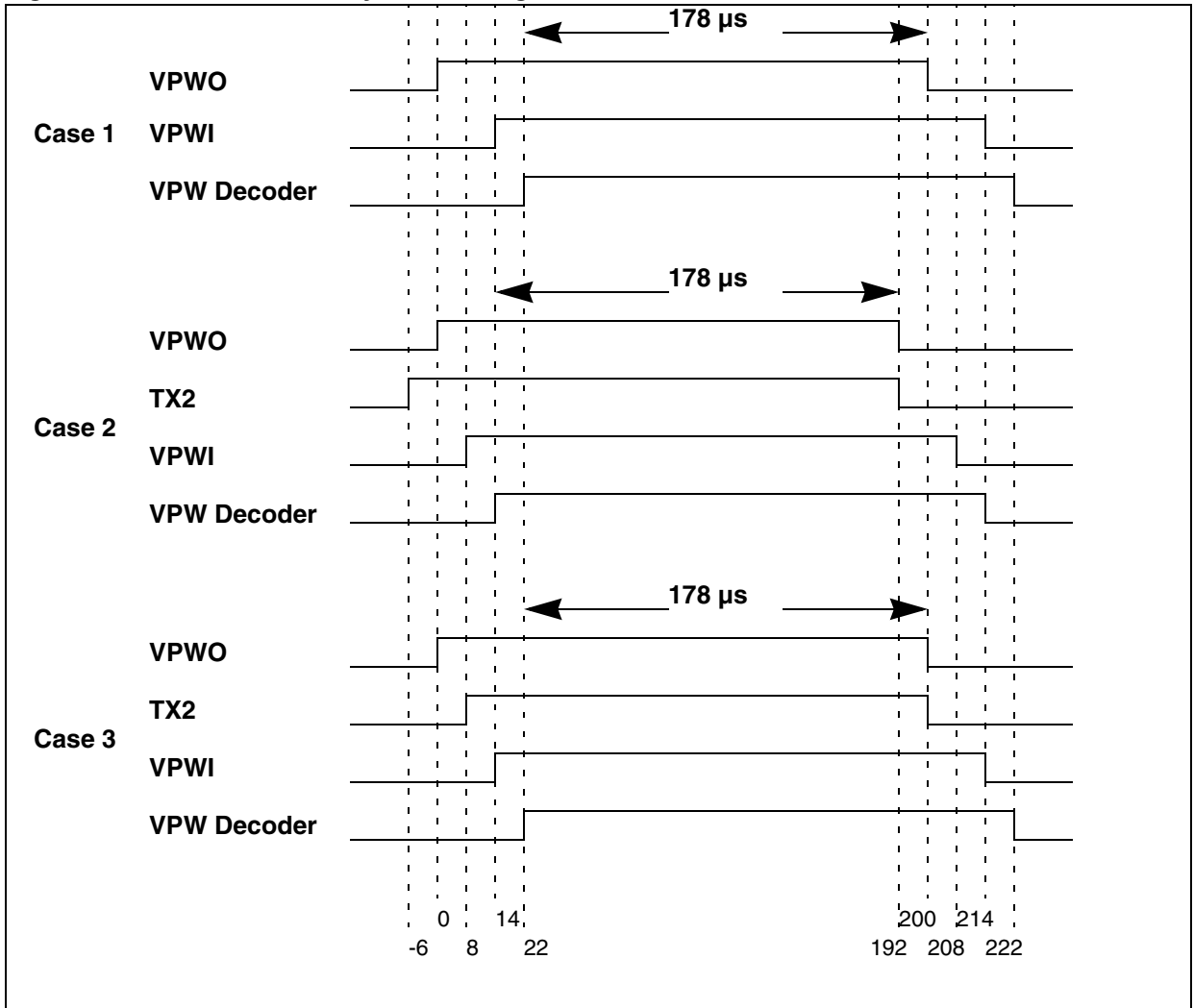

Figure 136. J1850 Received Symbol Timing



J1850 BYTE LEVEL PROTOCOL DECODER (Cont'd)

Use of symbol and bit synchronization is an integral part of the J1850 bus scheme. Therefore, tight coupling of the encoder and decoder functions is required to maintain synchronization during transmits. Transmitted symbols and bits are initiated by the encoder and are timed through the decoder to realize synchronization. Figure 136 exemplifies synchronization with 3 examples for an SOF symbol and JDLY[4:0] = 01110b.

Case 1 shows a single transmitter arbitrating for the bus. The VPWO pin is asserted, and 14 μ s later the bus transitions to an active state. The 14 μ s delay is due to the nominal delay through the external transceiver chip. The signal is echoed back to the transceiver through the VPWI pin, and proceeds through the digital filter. The digital filter has a loop delay of 8 clock cycles with the signal finally presented to the decoder 22 μ s after the VPWO pin was asserted. The decoder waits 178 μ s before issuing a signal to the encoder signifying the end of the symbol. The VPWO pin is de-asserted producing the nominal SOF bit timing (22 μ s + 178 μ s = 200 μ s).

Case 2 shows a condition where 2 transmitters attempt to arbitrate for the bus at nearly the same time with a second transmitter, TX2, beginning slightly earlier than the VPWO pin. Since the JBLPD always times symbols from its receiver perspective, 178 μ s after the decoder sees the rising edge it issues a signal to the encoder to signify the end of the SOF. Nominal SOF timings are maintained and the JBLPD re-synchronizes to TX2.

Case 3 again shows an example of 2 transmitters attempting to arbitrate for the bus at nearly the same time with the VPWO pin starting earlier than TX2. In this case TX2 is required to re-synchronize to VPWO.

All 3 examples exemplify how bus timings are driven from the receiver perspective. Once the receiver detects an active bus, the transmitter symbol timings are timed minus the transceiver and digital filter delays (i.e. SOF = 200 μ s - 14 μ s - 8 μ s = 178 μ s). This synchronization and timing off of the VPWI pin occurs for every symbol while transmitting. This ensures true arbitration during data byte transmissions.

10.9.3.3 Receiving Messages

Data is received from the external analog transceiver on the VPWI pin. VPWI data is immediately passed through a digital filter that ignores all pulses that are less than 7 μ s. Pulses greater than or equal to 7 μ s and less than 34 μ s are flagged as invalid bits (IBD) in the ERROR register.

Once data passes through the filter, all delimiters are stripped from the data stream and data bits are shifted into the receive shift register by the decoder logic. The first byte received after a valid SOF character is compared with the flags contained in FREG[0:31]. If the compare indicates that this message should be received, then the receive shift register contents are moved to the receive data register (RXDATA) for the user program to access. The Receive Data Register Full bit (RDRF) is set to indicate that a complete byte has been received. For each byte that is to be received in a frame, once an entire byte has been received, the receive shift register contents are moved to the receive data register (RXDATA). All data bits received, including CRC bits, are transferred to the RXDATA register. The Receive Data Register Full bit (RDRF) is set to indicate that a complete byte has been received.

If the first byte after a valid SOF indicates non-reception of this frame, then the current byte in the receive shift register is inhibited from being transferred to the RXDATA register and the RDRF flag remains clear (see the "Received Message Filtering" section). Also, no flags associated with receiving a message (RDOF, CRCE, IFD, IBD) are set.

A CRC check is kept on all bytes that are transferred to the RXDATA register during message byte reception (succeeding an SOF symbol) and IFR3 reception (succeeding an NBO symbol). The CRC is initialized on receipt of the first byte that follows an SOF symbol or an NBO symbol. The CRC check concludes on receipt of an EODM symbol. The CRC error bit (CRCE), therefore, gets set after the EODM symbol has been recognized. Refer to the "SAE Recommended Practice - J1850" manual for more information on CRCs.

J1850 BYTE LEVEL PROTOCOL DECODER (Cont'd)

Received Message Filtering

The FREG[0:31] registers can be considered an array of 256 bits (the FREG[0].0 bit is bit 0 of the array and the FREG[31].7 bit is bit 255). The I.D. byte of a message frame is used as a pointer to the array (See Figure 137).

Upon the start of a frame, the first data byte received after the SOF symbol determines the I.D. of the message frame. This I.D. byte addresses the I.D. byte flags stored in registers FREG[0:31]. This operation is accomplished before the transfer of the I.D. byte into the RXDATA register and before the RDRF bit is set.

If the corresponding bit in the message filter array, FREG[0:31], is set to zero (0), then the I.D. byte is not transferred to the RXDATA register and the RDRF bit is not set. Also, the remainder of the message frame is ignored until reception of an EOFmin symbol. A received EOFmin symbol terminates the operation of the message filter and enables the receiver for the next message. None of the flags related to the receiver, other than IDLE, are set. The EODM flag does not get set during a filtered frame. No error flags other than RBRK can get set.

If the corresponding bit in the message filter array, FREG[0:31], is set to a one (1), then the I.D. byte is transferred to the RXDATA register and the RDRF is set. Also, the remainder of the message is received unless sleep mode is invoked by the

user program. All receiver flags and interrupts function normally.

Note that a break symbol received during a filtered out message will still be received. Note also that the filter comparison occurs after reception of the first byte. So, any receive errors that occur before the message filter comparison (i.e. IBD, IFD) will be active at least until the filter comparison.

Transmitted Message Filtering

When transmitting a message, the corresponding FREG[0:31] I.D. filter bit may be set or cleared. If set, then the JBLPD will receive all data information transferred during the frame, unless sleep mode is invoked. Everything the JBLPD transmits will be reflected in the RXDATA register.

Because the JBLPD has invalid bit detect (IBD), invalid frame detect (IFD), transmitter lost arbitration (TRA), and Cyclic Redundancy Check Error (CRCE) it is not necessary for the transmitter to listen to the bytes that it is transmitting. The user may wish to filter out the transmitted messages from the receiver. This can reduce interrupt burden. When a transmitted I.D. byte is filtered by the receiver section of the block, then RDRF, RDOF, EODM flags are inhibited and no RXDATA transfers occur. The other flags associated normally with receiving - RBRK, CRCE, IFD, and IBD - are not inhibited, and they can be used to ascertain the condition of the message transmit.

Figure 137. I.D. Byte and Message Filter Array use

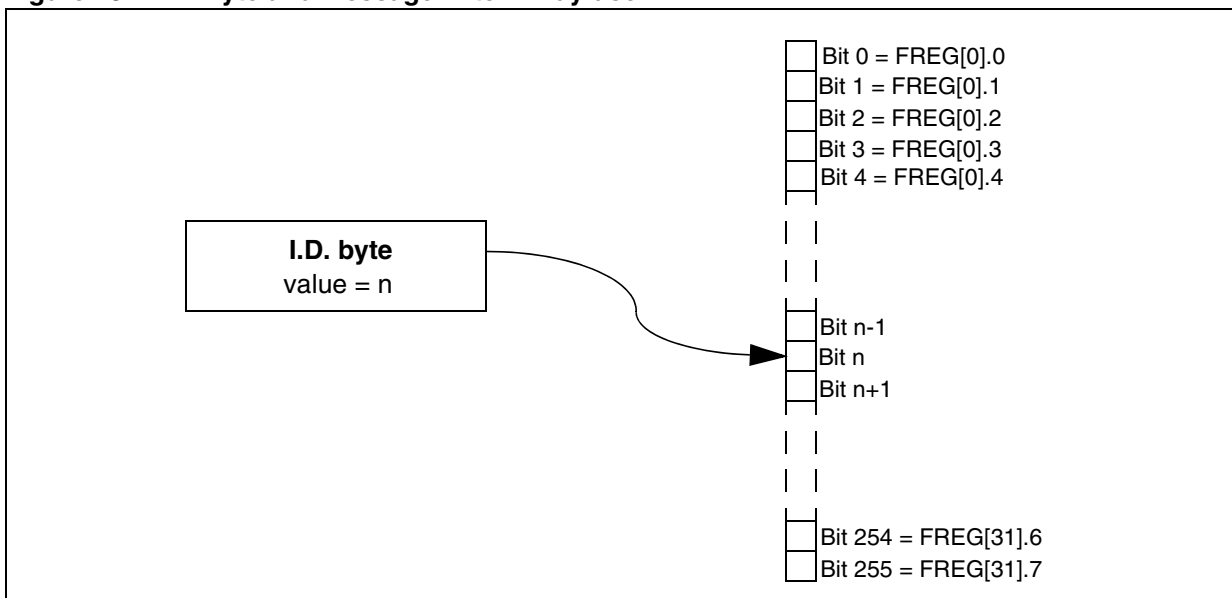

J1850 BYTE LEVEL PROTOCOL DECODER (Cont'd)

10.9.3.4 Sleep Mode

Sleep mode allows the user program to ignore the remainder of a message. Normally, the user program can recognise if the message is of interest from the header bytes at the beginning of the message. If the user program is not interested in the message it simply writes the SLP bit in the PRLR register. This causes all additional data on the bus to be ignored until an EOF minimum occurs. No additional flags (but not the EOFM flag) and, therefore, interrupts are generated for the remainder of the message. The single exception to this is a received break symbol while in sleep mode. Break symbols always take precedence and will set the RBRK bit in the ERROR register and generate an interrupt if the ERR_M bit in IMR is set. Sleep mode and the SLP bit gets cleared on reception of an EOF or Break symbol.

Writes to the SLP bit will be ignored if:

- 1) A valid EOFM symbol was the last valid symbol detected,

AND

- 2) The J1850 bus line (after the filter) is passive.

Therefore, sleep mode can only be invoked after the SOF symbol and subsequent data has been received, but before a valid EOF is detected. If sleep mode is invoked within this time window, then any queued IFR transmit is aborted. If a MSG type is queued and sleep mode is invoked, then the MSG type will remain queued and an attempt to transmit will occur after the EOF period has elapsed as usual.

If SLP mode is invoked while the JBLPD is currently transmitting, then the JBLPD effectively inhibits the RDRF, RDT, EODM, & RDOF flags from being set, and disallows RXDATA transfers. But, it otherwise functions normally as a transmitter, still allow-

ing the TRDY, TLA, TTO, TDUF, TRA, IBD, IFD, and CRCE bits to be set if required. This mode allows the user to not have to listen while talking.

10.9.3.5 Normalization Bit symbol selection

The form of the NB0/NB1 symbol changes depending on the industry standard followed. A bit (NBSYMS) in the OPTIONS register selects the symbol timings used. Refer to [Table 54](#).

10.9.3.6 VPWI input line management

The JBLPD is able to work with J1850 transceiver chips that have both inverted and not inverted RX signal. A dedicated bit (INPOL) of the OPTIONS register must be programmed with the correct value depending on the polarity of the VPWI input with respect to the J1850 bus line. Refer to the INPOL bit description for more details.

10.9.3.7 Loopback mode

The JBLPD is able to work in loopback mode. This mode, enabled setting the LOOPB bit of the OPTIONS register, internally connects the output signal (VPWO) of the JBLPD to the input (VPWI) without polarity inversion. The external VPWO pin of the MCU is forced in its passive state and the external VPWI pin is ignored (Refer to [Figure 138](#)).

Note: When the LOOPB bit is set or reset, edges could be detected by the J1850 decoder on the internal VPWI line. These edges could be managed by the JBLPD as J1850 protocol errors. It is suggested to enable/disable LOOPB when the JBLPD is suspended (CONTROL.JE=0, CONTROL.JDIS=0) or when the JBLPD is disabled (CONTROL.JDIS=1).

Table 54. Normalization Bit configurations

	Symbol	NBSYMS=0	NBSYMS=1
IFR with CRC	NB0	active Tv2 (active long)	active Tv1 (active short)
IFR without CRC	NB1	active Tv1 (active short)	active Tv2 (active long)

J1850 BYTE LEVEL PROTOCOL DECODER (Cont'd)

Figure 138. Local Loopback structure

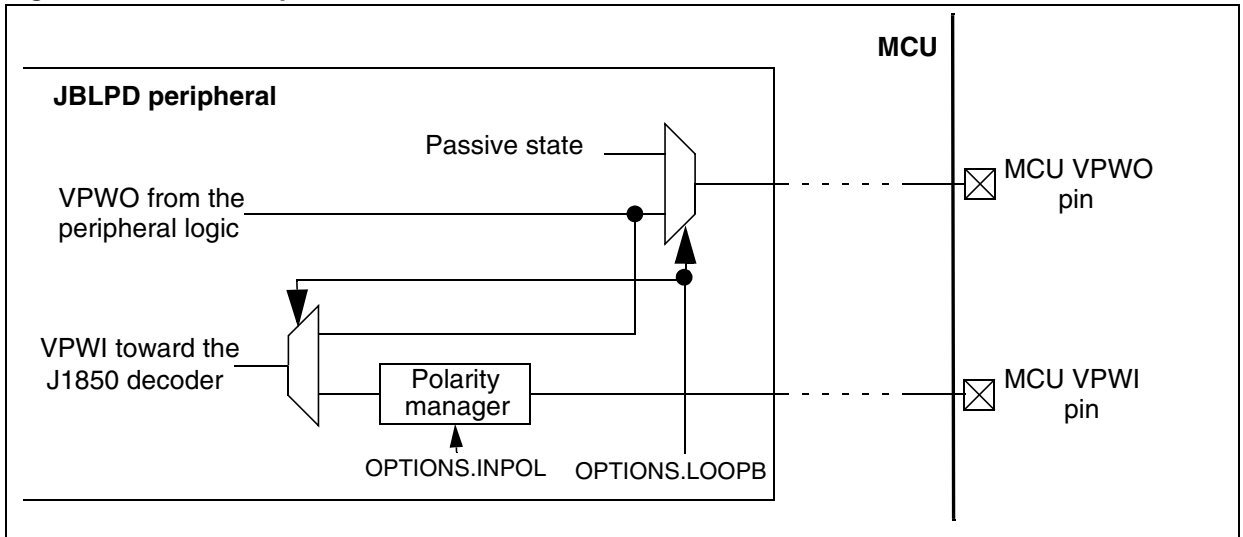

10.9.3.8 Peripheral clock management

To work correctly, the encoder and decoder sections of the peripheral need an internal clock at 1MHz. This clock is used to evaluate the protocol symbols timings in transmission and in reception.

The prescaled clock is obtained by dividing the MCU internal clock frequency. The CLKSEL register allows the selection of the right prescaling factor. The six least significant bits of the register

(FREQ[5:0]) must be programmed with a value using the following formula:

$$\text{MCU Internal Freq.} = 1\text{MHz} * (\text{FREQ}[5:0] + 1).$$

Note: If the MCU internal clock frequency is lower than 1MHz, the JBLPD is not able to work correctly. If a frequency lower than 1MHz is used, the user program must disable the JBLPD.

Note: When the MCU internal clock frequency or the clock prescaler factor are changed, the JBLPD could lose synchronization with the J1850 bus.

J1850 BYTE LEVEL PROTOCOL DECODER (Cont'd)

10.9.4 Peripheral Functional Modes

The JBLPD can be programmed in 3 modes, depending on the value of the JE and JDIS bits in the CONTROL register, as shown in [Table 55](#).

Table 55. JBLPD functional modes

JE	JDIS	mode
0	1	JBLPD Disabled
0	0	JBLPD Suspended
1	0	JBLPD Enabled

Depending on the mode selected, the JBLPD is able or unable to transmit or receive messages. Moreover the power consumption of the peripheral is affected.

Note: The configuration with both JE and JDIS set is forbidden.

10.9.4.1 JBLPD Enabled

When the JBLPD is enabled (CONTROL.JE=1), it is able to transmit and receive messages. Every feature is available and every register can be written.

10.9.4.2 JBLPD Suspended (Low Power Mode)

When the JBLPD is suspended (CONTROL.JE=0 and CONTROL.JDIS=0), all the logic of the JBLPD is stopped except the decoder logic. This feature allows a reduction of power consump-

tion when the JBLPD is not used, even if the decoder is able to follow the bus traffic. So, at any time the JBLPD is enabled, it is immediately synchronized with the J1850 bus.

Note: While the JBLPD is suspended, the STATUS register, the ERROR register and the SLP bit of the PRLR register are forced into their reset value.

10.9.4.3 JBLPD Disabled (Very Low Power Mode)

Setting the JDIS bit in the CONTROL register, the JBLPD is stopped until the bit is reset by software. Also the J1850 decoder is stopped, so the JBLPD is no longer synchronized with the bus. When the bit is reset, the JBLPD will wait for a new idle state on the J1850 bus. This mode can be used to minimize power consumption when the JBLPD is not used.

Note: While the JDIS bit is set, the STATUS register, the ERROR register, the IMR register and the SLP, TEOBP and REOBP bits of the PRLR register are forced to their reset value.

Note: In order that the JDIS bit is able to reset the IMR register and the TEOBP and REOBP bits, the JDIS bit must be left at 1 at least for 6 MCU clock cycles (3 NOPs).

Note: The JE bit of CONTROL register cannot be set with the same instruction that reset the JDIS bit. It can be set only after the JDIS bit is reset.

J1850 BYTE LEVEL PROTOCOL DECODER (Cont'd)

10.9.5 Interrupt Features

The JBLPD has six interrupt sources that it handles using the internal interrupts protocol. Other two interrupt sources (REOB and TEOB) are related to the DMA feature (See [Section 10.9.6 DMA Features](#)).

No external interrupt channel is used by the JBLPD.

The dedicated registers of the JBLPD should be loaded with appropriate values to set the interrupt vector (see the description of the IVR register), the interrupt mask bits (see the description of the IMR register) and the interrupt pending bits (see the description of the STATUS and PRLR registers).

The interrupt sources are as follows:

- The ERROR interrupt is generated when the ERROR bit of the STATUS register is set. This bit is set when the following events occur: Transmitter Timeout, Transmitter Data Underflow, Receiver Data Overflow, Transmit Request Aborted, Received Break Symbol, Cyclic Redundancy Check Error, Invalid Frame Detect, Invalid Bit Detect (a more detailed description of these events is given in the description of the ERROR register).
- The TLA interrupt is generated when the transmitter loses the arbitration (a more detailed description of this condition is given in the TLA bit description of the STATUS register).
- The EODM interrupt is generated when the JBLPD detects a passive level on the VPWI line longer than the minimum time accepted by the standard for the End Of Data symbol (a more detailed description of this condition is given in the EODM bit description of the STATUS register).
- The EOFM interrupt is generated when the JBLPD detects a passive level on the VPWI line longer than the minimum time accepted by the standard for the End Of Frame symbol (a more detailed description of this condition is given in the EOFM bit description of the STATUS register).

- The RDRF interrupt is generated when a complete data byte has been received and placed in the RXDATA register (see also the RDRF bit description of the STATUS register).
- The REOB (Receive End Of Block) interrupt is generated when receiving using DMA and the last byte of a sequence of data is read from the JBLPD.
- The TRDY interrupt is generated by two conditions: when the TXOP register is ready to accept a new opcode for transmission; when the transmit state machine accepts the opcode for transmission (a more detailed description of this condition is given in the TRDY bit description of the STATUS register).
- The TEOB (Transmit End Of Block) interrupt is generated when transmitting using DMA and the last byte of a sequence of data is written to the JBLPD.

10.9.5.1 Interrupt Management

To use the interrupt features the user has to follow these steps:

- Set the correct priority level of the JBLPD
- Set the correct interrupt vector
- Reset the Pending bits
- Enable the required interrupt source

Note: It is strongly recommended to reset the pending bits before un-masking the related interrupt sources to avoid spurious interrupt requests.

The priority with respect the other ST9 peripherals is programmable by the user setting the three most significant bits of the Interrupt Priority Level register (PRLR). The lowest interrupt priority is obtained by setting all the bits (this priority level is never acknowledged by the CPU and is equivalent to disabling the interrupts of the JBLPD); the highest interrupt priority is programmed resetting the bits. See the Interrupt and DMA chapters of the datasheet for more details.

When the JBLPD interrupt priority is set, the priority between the internal interrupt sources is fixed by hardware as shown in [Table 56](#).

J1850 BYTE LEVEL PROTOCOL DECODER (Cont'd)

Note: After an MCU reset, the DMA requests of the JBLPD have a higher priority than the interrupt requests.

If the DMASUSP bit of the OPTIONS register is set, while the ERROR and TLA flags are set, no DMA transfer will be performed, allowing the relevant interrupt routines to manage each condition and, if necessary, disable the DMA transfer (Refer to [Section 10.9.6 DMA Features](#)).

Table 56. JBLPD internal priority levels

Priority Level	Interrupt Source
Higher	ERROR, TLA
	EODM, EOFM
	RDRF, REOB
Lower	TRDY, TEOB

The user can program the most significant bits of the interrupt vectors by writing the V[7:3] bits of the IVR register. Starting from the value stored by the user, the JBLPD sets the three least significant bits of the IVR register to produce four interrupt vectors that are associated with interrupt sources as shown in [Table 57](#).

Table 57. JBLPD interrupt vectors

Interrupt Vector	Interrupt Source
V[7:3] 000b	ERROR, TLA
V[7:3] 010b	EODM, EOFM
V[7:3] 100b	RDRF, REOB
V[7:3] 110b	TRDY, TEOB

Each interrupt source has a pending bit in the STATUS register, except the DMA interrupt sources that have the interrupt pending bits located in the PRLR register.

These bits are set by hardware when the corresponding interrupt event occurs. An interrupt request is performed only if the related mask bits are set in the IMR register and the JBLPD has priority. The pending bits have to be reset by the user software. Note that until the pending bits are set (while the corresponding mask bits are set), the JBLPD processes interrupt requests. So, if at the end of an interrupt routine the related pending bit is not reset, another interrupt request is performed.

To reset the pending bits, different actions have to be done, depending on each bit: see the description of the STATUS and PRLR registers.

J1850 BYTE LEVEL PROTOCOL DECODER (Cont'd)

10.9.6 DMA Features

The JBLPD can use the ST9 on-chip Direct Memory Access (DMA) channels to provide high-speed data transactions between the JBLPD and contiguous locations of Register File and Memory. The transactions can occur from and toward the JBLPD. The maximum number of transactions that each DMA channel can perform is 222 with Register File or 65536 with Memory. Control of the DMA features is performed using registers located in the JBLPD register page (IVR, PRLR, IMR, RDAPR, RDCPR, TDAPR, TDCPR).

The priority level of the DMA features of the JBLPD with respect to the other ST9 peripherals and the CPU is the same as programmed in the PRLR register for the interrupt sources. In the internal priority level order of the JBLPD, depending on the value of the DMASUSP bit in the OPTIONS register, the DMA may or may not have a higher priority than the interrupt sources. Refer to the Interrupt and DMA chapters of the datasheet for details on priority levels.

The DMA features are enabled by setting the appropriate enabling bits (RXD_M, TXD_M) in the IMR register. It is also possible to select the direction of the DMA transactions.

Once the DMA table is completed (the transaction counter reaches 0 value), an interrupt request to the CPU is generated if the related mask bit is set (RDRF_M bit in reception, TRDY_M bit in transmission). This kind of interrupt is called "End Of Block". The peripheral sends two different "End Of Block" interrupts depending on the direction of the DMA (Receiving End Of Block (REOB) - Transmitting End Of Block (TEOB)). These interrupt sources have dedicated interrupt pending bits in the PRLR register (REOBP, TEOBP) and they are mapped to the same interrupt vectors: "Receive Data Register Full (RDRF)" and "Transmit Ready (TRDY)" respectively. The same correspondence exists for the internal priority between interrupts and interrupt vectors.

10.9.6.1 DMA between JBLPD and Register File

If the DMA transaction is made between the JBLPD and the Register File, one register is required to hold the DMA Address and one to hold the DMA transaction counter. These two registers must be located in the Register File: the DMA Address Register in an even addressed register, the DMA Transaction Counter in the following register

(odd address). They are pointed to by the DMA Transaction Counter Pointer Register (RDCPR register in receiving, TDCPR register in transmitting) located in the JBLPD register page.

To select DMA transactions with the Register File, the control bits RDCPR.RF/MEM in receiving mode or TDCPR.RF/MEM in transmitting mode must be set.

The transaction Counter Register must be initialized with the number of DMA transfers to perform and it will be decremented after each transaction. The DMA Address Register must be initialized with the starting address of the DMA table in the Register File, and it is incremented after each transaction. These two registers must be located between addresses 00h and DFh of the Register File.

When the DMA occurs between JBLPD and Register File, the TDAPR register (in transmission) and the RDAPR register (in reception) are not used.

10.9.6.2 DMA between JBLPD and Memory Space

If the DMA transaction is made between the JBLPD and Memory, a register pair is required to hold the DMA Address and another register pair to hold the DMA Transaction counter. These two pairs of registers must be located in the Register File. The DMA Address pair is pointed to by the DMA Address Pointer Registers (RDAPR register in reception, TDAPR register in transmission) located in the JBLPD register page; the DMA Transaction Counter pair is pointed to by the DMA Transaction Counter Pointer Registers (RDCPR register in reception, TDCPR register in transmission) located in the JBLPD register page.

To select DMA transactions with Memory Space, the control bits RDCPR.RF/MEM in receiving mode or TDCPR.RF/MEM in transmitting mode must be reset.

The Transaction Counter register pair must be initialized with the number of DMA transfers to perform and it will be decremented after each transaction. The DMA Address register pair must be initialized with the starting address of the DMA table in Memory Space, and it is incremented after each transaction. These two register pairs must be located between addresses 00h and DFh of the Register File.

J1850 BYTE LEVEL PROTOCOL DECODER (Cont'd)

10.9.6.3 DMA Management in Reception Mode

The DMA in reception is performed when the RDRF bit of the STATUS register is set (by hardware). The RDRF bit is reset as soon as the DMA cycle is finished.

To enable the DMA feature, the RXD_M bit of the IMR register must be set (by software).

Each DMA request performs the transfer of a single byte from the RXDATA register of the peripheral toward Register File or Memory Space (Figure 139).

Each DMA transfer consists of three operations that are performed with minimum use of CPU time:

- A load from the JBLPD data register (RXDATA) to a location of Register File/Memory addressed

through the DMA Address Register (or Register pair);

- A post-increment of the DMA Address Register (or Register pair);
- A post-decrement of the DMA transaction counter, which contains the number of transactions that have still to be performed.

Note: When the REOBP pending bit is set (at the end of the last DMA transfer), the reception DMA enable bit (RXD_M) is automatically reset by hardware. However, the DMA can be disabled by software resetting the RXD_M bit.

Note: The DMA request acknowledge could depend on the priority level stored in the PRLR register.

Figure 139. DMA in Reception Mode

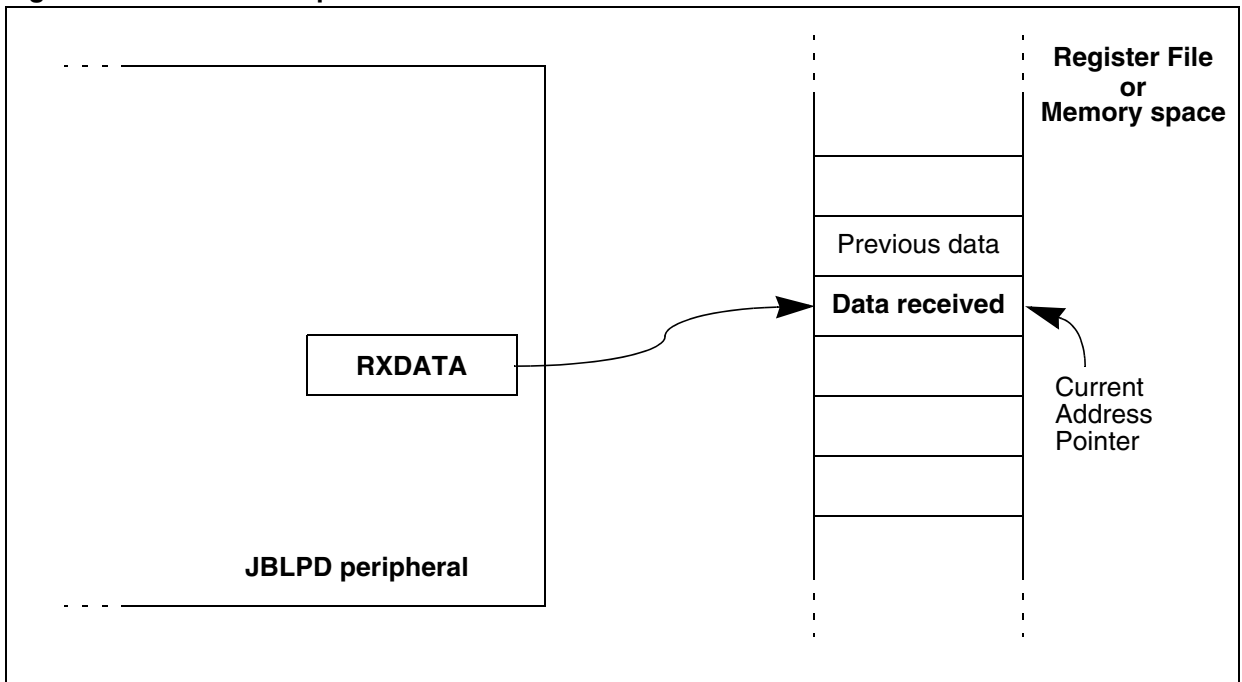

J1850 BYTE LEVEL PROTOCOL DECODER (Cont'd)

10.9.6.4 DMA Management in Transmission Mode

DMA in transmission is performed when the TRDY bit of the STATUS register is set (by hardware). The TRDY bit is reset as soon as the DMA cycle is finished.

To enable the DMA feature, the TXD_M bit in the IMR register must be set (by software).

Compared to reception, in transmission each DMA request performs the transfer of either a single byte or a couple of bytes depending on the value of the Transmit Opcode bits (TXOP.OP[2:0]) written during the DMA transfer.

The table of values managed by the DMA must be a sequence of opcode bytes (that will be written in the TXOP register by the DMA) each one followed by a data byte (that will be written in the TXDATA register by the DMA) if the opcode needs it (see [Figure 140](#)).

Each DMA cycle consists of the following transfers for a total of three/six operations that are performed with minimum use of CPU time:

- A load to the JBLPD Transmit Opcode register (TXOP) from a location of Register File/Memory addressed through the DMA Address Register (or Register pair);
- A post-increment of the DMA Address Register (or Register pair);
- A post-decrement of the DMA transaction counter, which contains the number of transactions that have still to be performed;

and if the Transmit Opcode placed in TXOP requires a datum:

- A load to the peripheral data register (TXDATA) from a location of Register File/Memory addressed through the DMA Address Register (or

Register pair); it is the next location in the TXDATA transfer cycle;

- A post-increment of the DMA Address Register (or Register pair);
- A post-decrement of the DMA transaction counter, which contains the number of transactions that have still to be performed.

Note: When the TEOBP pending bit is set (at the end of the last DMA transfer), the transmission DMA enable bit (TXD_M) is automatically reset by hardware. However, the DMA can be disabled by software resetting the TXD_M bit.

Note: When using DMA, the TXOP byte is written before the TXDATA register. This order is accepted by the JBLPD **only** when the DMA in transmission is enabled.

Note: The DMA request acknowledge could depend on the priority level stored in the PRLR register. In the same way, some time can occur between the transfer of the first byte and the transfer of the second one if another interrupt or DMA request with higher priority occurs.

10.9.6.5 DMA Suspend mode

In the JBLPD it is possible to suspend or not to suspend the DMA transfer while some J1850 protocol events occur. The selection between the two modes is done by programming the DMASUSP bit of the OPTIONS register.

If the DMASUSP bit is set (DMA suspended mode), while the ERROR or TLA flag is set, the DMA transfers are suspended, to allow the user program to handle the event condition.

If the DMASUSP bit is reset (DMA not suspended mode), the previous flags have no effect on the DMA transfers.

J1850 BYTE LEVEL PROTOCOL DECODER (Cont'd)

Figure 140. DMA in Transmission Mode

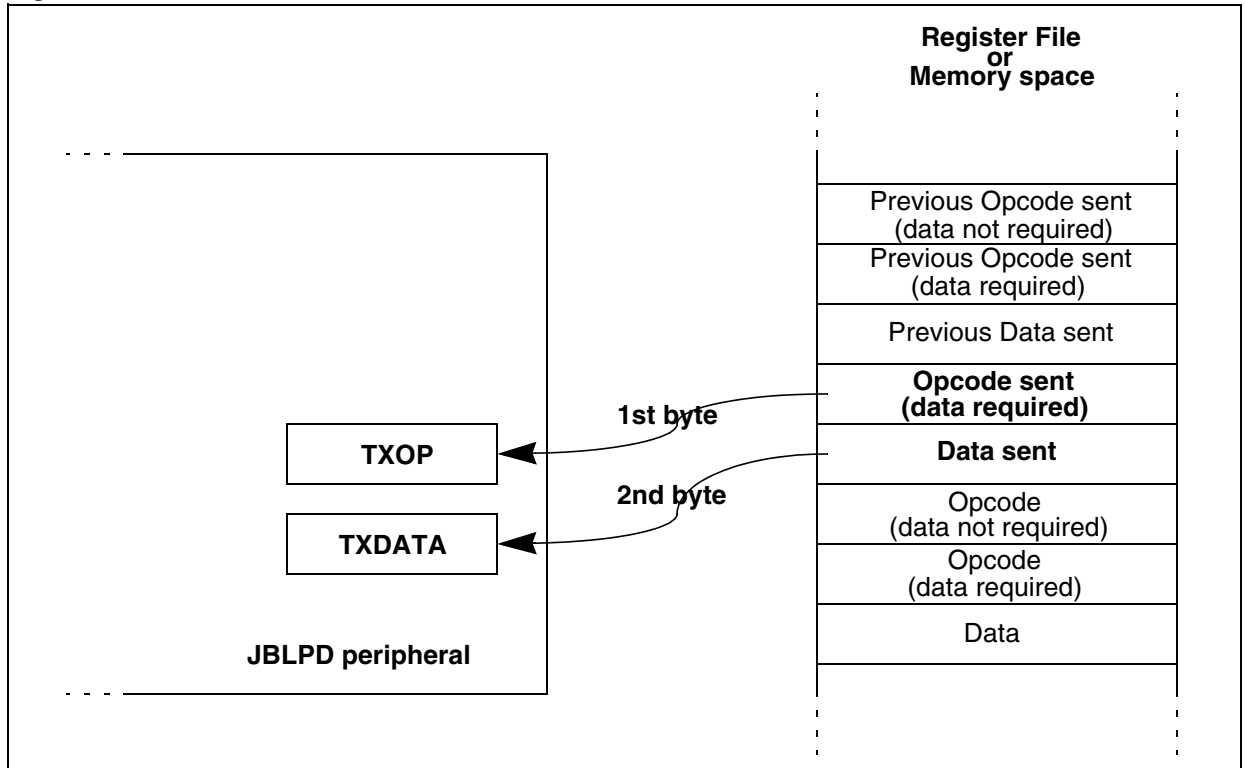

J1850 BYTE LEVEL PROTOCOL DECODER (Cont'd)

10.9.7 Register Description

The JBLPD peripheral uses 48 registers that are mapped in a single page of the ST9 register file.

Twelve registers are mapped from R240 (F0h) to R251 (FBh): these registers are usually used to control the JBLPD. See [Section 10.9.7.1 Un-Stacked Registers](#) for a detailed description of these registers.

Thirty-six registers are mapped from R252 (FCh) to R255 (FFh). This is obtained by creating 9 sub-pages, each containing 4 registers, mapped in the same register addresses; 4 bits (RSEL[3:0]) of a

register (OPTIONS) are used to select the current sub-page. See [Section 10.9.7.2 Stacked Registers](#) section for a detailed description of these registers.

The ST9 Register File page used is 23 (17h).

NOTE: Bits marked as “Reserved” should be left at their reset value to guarantee software compatibility with future versions of the JBLPD.

Figure 141. JBLPD Register Map

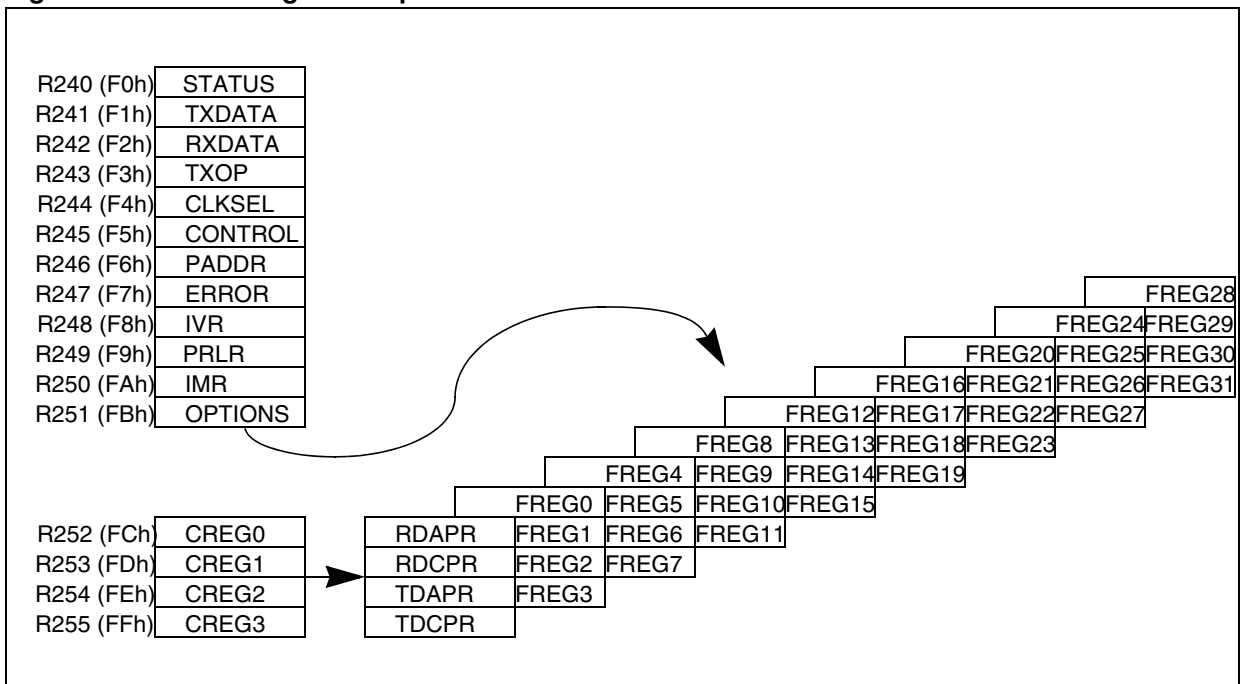

J1850 BYTE LEVEL PROTOCOL DECODER (Cont'd)

10.9.7.1 Un-Stacked Registers

STATUS REGISTER (STATUS)

R240 - Read/Write

Register Page: 23

Reset Value: 0100 0000 (40h)

7							0
ERR	TRDY	RDRF	TLA	RDT	EODM	EOFM	IDLE

The bits of this register indicate the status of the JBLPD peripheral.

This register is forced to its reset value after the MCU reset and while the CONTROL.JDIS bit is set. While the CONTROL.JE bit is reset, all bits except IDLE are forced to their reset values.

Bit 7 = ERR Error Flag.

The ERR bit indicates that one or more bits in the ERROR register have been set. As long as any bit in the ERROR register remains set, the ERR bit remains set. When all the bits in the ERROR register are cleared, then the ERR bit is reset by hardware. The ERR bit is also cleared on reset or while the CONTROL.JE bit is reset, or while the CONTROL.JDIS bit is set.

If the ERR_M bit of the IMR register is set, when this bit is set an interrupt request occurs.

0: No error

1: One or more errors have occurred

Bit 6 = TRDY Transmit Ready Flag.

The TRDY bit indicates that the TXOP register is ready to accept another opcode for transmission. The TRDY bit is set when the TXOP register is empty and it is cleared whenever the TXOP register is written (by software or by DMA). TRDY will be set again when the transmit state machine accepts the opcode for transmission.

When attempting to transmit a data byte without using DMA, two writes are required: first a write to TXDATA, then a write to the TXOP.

– If a byte is written into the TXOP which results in TRA getting set, then the TRDY bit will immediately be set.

– If a TLA occurs and the opcode for which TRDY is low is scheduled for this frame, then TRDY will go high, if the opcode is scheduled for the next frame, then TRDY will stay low.

– If an IBD, IFD or CRCE error condition occurs, then TRDY will be set and any queued transmit opcode scheduled to transmit in the present frame will be cancelled by the JBLPD peripheral. A MSGx opcode scheduled to be sent in the

next frame will not be cancelled for these errors, so TRDY would not get set.

– An RBRK error condition cancels all transmits for this frame or any successive frames, so the TRDY bit will always be immediately set on an RBRK condition.

TRDY is set on reset or while CONTROL.JE is reset, or while the CONTROL.JDIS bit is set.

If the TRDY_M bit of the IMR register is set, when this bit is set an interrupt request occurs.

0: TXOP register not ready to receive a new opcode

1: TXOP register ready to receive a new opcode

Bit 5 = RDRF Receive Data Register Full Flag.

RDRF is set when a complete data byte has been received and transferred from the serial shift register to the RXDATA register.

RDRF is cleared when the RXDATA register is read (by software or by DMA). RDRF is also cleared on reset or while CONTROL.JE is reset, or while CONTROL.JDIS bit is set.

If the RDRF_M bit of the IMR register is set, when this bit is set an interrupt request occurs.

0: RXDATA register doesn't contain a new data

1: RXDATA register contains a new data

Bit 4 = TLA Transmitter Lost Arbitration.

The TLA bit gets set when the transmitter loses arbitration while transmitting messages or type 1 and 3 IFRs. Lost arbitration for a type 2 IFR does not set the TLA bit. (Type 2 messages require retries of the physical address if the arbitration is lost until the frame length is reached (if NFL=0)). The TLA bit gets set when, while transmitting a MSG, MSG+CRC, IFR1, IFR3, or IFR3+CRC, the decoded VPWI data bit symbol received does not match the VPWO data bit symbol that the JBLPD is attempting to send out. If arbitration is lost, the VPWO line is switched to its passive state and nothing further is transmitted until an end-of-data (EOD) symbol is detected on the VPWI line. Also, any queued transmit opcode scheduled for transmission during this frame is cancelled (but the TRA bit is not set).

The TLA bit can be cleared by software writing a logic "zero" in the TLA position. TLA is also cleared on reset or while CONTROL.JE is reset, or while CONTROL.JDIS bit is set.

If the TLA_M bit of the IMR register is set, when this bit is set an interrupt request occurs.

0: The JBLPD doesn't lose arbitration

1: The JBLPD loses arbitration

J1850 BYTE LEVEL PROTOCOL DECODER (Cont'd)

Bit 3 = **RDT** *Receive Data Type*.

The RDT bit indicates the type of data which is in the RXDATA register: message byte or IFR byte. Any byte received after an SOF but before an EODM is considered a message byte type. Any byte received after an SOF, EODM and NBx is an IFR type.

RDT gets set or cleared at the same time that RDRF gets set.

RDT is cleared on reset or while CONTROL.JE is reset, or while CONTROL.JDIS bit is set.

0: Last RXDATA byte was a message type byte
1: Last RXDATA byte was a IRF type byte

Bit 2 = **EODM** *End of Data Minimum Flag*.

The EODM flag is set when the JBLPD decoded VPWI pin has been in a passive state for longer than the minimum Tv3 symbol time unless the EODM is inhibited by a sleep, filter or CRCE, IBD, IFD or RBRK error condition during a frame. EODM bit does not get set when in the sleep mode or when a message is filtered.

The EODM bit can be cleared by software writing a logic “zero” in the EODM position. EODM is cleared on reset, while CONTROL.JE is reset or while CONTROL.JDIS bit is set.

If the EODM_M bit of the IMR register is set, when this bit is set an interrupt request occurs.

0: No EOD symbol detected
1: EOD symbol detected

Note: The EODM bit is not an error flag. It means that the minimum time related to the passive Tv3 symbol is passed.

Bit 1 = **EOFM** *End of Frame Minimum Flag*.

The EOFM flag is set when the JBLPD decoded VPWI pin has been in a passive state for longer than the minimum Tv4 symbol time. EOFM will still get set at the end of filtered frames or frames where sleep mode was invoked. Consequently, multiple EOFM flags may be encountered between frames of interest.

The EOFM bit can be cleared by software writing a logic “zero” in the EOFM position. EOFM is cleared on reset, while CONTROL.JE is reset or while CONTROL.JDIS bit is set.

If the EOFM_M bit of the IMR register is set, when this bit is set an interrupt request occurs.

0: No EOF symbol detected
1: EOF symbol detected

Note: The EOFM bit is not an error flag. It means that the minimum time related to the passive Tv4 symbol is passed.

Bit 0 = **IDLE** *Idle Bus Flag*

IDLE is set when the JBLPD decoded VPWI pin recognized an IFS symbol. That is, an idle bus is when the bus has been in a passive state for longer than the Tv6 symbol time. The IDLE flag will remain set as long as the decoded VPWI pin is passive. IDLE is cleared when the decoded VPWI pin transitions to an active state.

Note that if the VPWI pin remains in a passive state after JE is set, then the IDLE bit may go high sometime before a Tv6 symbol is timed on VPWI (since VPWI timers may be active when JE is clear).

IDLE is cleared on reset or while the CONTROL.JDIS bit is set.

0: J1850 bus not in idle state
1: J1850 bus in idle state

JBLPD TRANSMIT DATA REGISTER (TXDATA)

R241- Read/Write

Register Page: 23

Reset Value: xxxx xxxx (xxh)

7							0
TXD7	TXD6	TXD5	TXD4	TXD3	TXD2	TXD1	TXD0

The TXDATA register is an eight bits read/write register in which the data to be transmitted must be placed. A write to TXDATA merely enters a byte into the register. To initiate an attempt to transmit the data, the TXOP register must also be written. When the TXOP write occurs, the TRDY flag is cleared. While the TRDY bit is clear, the data is still in the TXDATA register, so writes to the TXDATA register with TRDY clear will overwrite existing TXDATA. When the TXDATA is transferred to the shift register, the TRDY bit is set again.

Reads of the TXDATA register will always return the last byte written.

TXDATA contents are undefined after a reset.

Note: The correct sequence to transmit is to write first the TXDATA register (if datum is needed) and then the TXOP one.

Only using the DMA, the correct sequence of writing operations is first the TXOP register and then the TXDATA one (if needed).

J1850 BYTE LEVEL PROTOCOL DECODER (Cont'd)

JBLPD RECEIVE DATA REGISTER (RXDATA)

R242- Read only
Register Page: 23

Reset Value: xxxx xxxx (xxh)

7							0
RXD7	RXD6	RXD5	RXD4	RXD3	RXD2	RXD1	RXD0

The RXDATA register is an 8-bit read only register in which the data received from VPWI is stored. VPWI data is transferred from the input VPW decoder to a serial shift register unless it is inhibited by sleep mode, filter mode or an error condition (IBD, IFD, CRCE, RBRK) during a frame. When the shift register is full, this data is transferred to the RXDATA register, and the RDRF flag gets set. All received data bytes are transferred to RXDATA including CRC bytes. A read of the RXDATA register will clear the RDRF flag.

Note that care must be taken when reading RXDATA subsequent to an RDRF flag. Multiple reads of RXDATA after an RDRF should only be attempted if the user can be sure that another RDRF will not occur by the time the read takes place.

RXDATA content is undefined after a reset.

JBLPD TRANSMIT OPCODE REGISTER (TXOP)

R243 - Read/Write
Register Page: 23

Reset Value: 0000 0000 (00h)

7							0
MLC3	MLC2	MLC1	MLC0	-	OP2	OP1	OP0

TXOP is an 8-bit read/write register which contains the instructions required by the JBLPD to transmit

a byte. A write to the TXOP triggers the state machine to initialize an attempt to serially transmit a byte out on the VPWO pin. An opcode which triggers a message byte or IFR type 3 to be sent will transfer the TXDATA register contents to the transmit serial shift register. An opcode which triggers a message byte or IFR type 3 to be sent with a CRC appended will transfer the TXDATA register contents to the transmit serial shift register and subsequently the computed CRC byte. An opcode which triggers an IFR type 1 or 2 to be sent will transfer the PADDR register contents to the transmit serial shift register. If a TXOP opcode is written which is invalid for the bus conditions at the time (e.g. 12 byte frame or IFR3ing an IFR2), then no transmit attempt is tried and the TRA bit in the ER-ROR register is set.

Transmission of a string of data bytes requires multiple TXDATA/TXOP write sequences. Each write combination should be accomplished while the TRDY flag is set. However, writes to the TXOP when TRDY is not set will be accepted by the state machine, but it may override the previous data and opcode.

Under normal message transmission conditions the MSG opcode is written. If the last data byte of a string is to be sent, then the MSG+CRC opcode will be written. An IFRx opcode is written if a response byte or bytes to a received message (i.e. bytes received in RXDATA with RDT=0) is wanted to transmit. The Message Length Count bits (MLC[3:0]) may be used to require that the IFR be enabled only if the correct number of message bytes has been received.

NOTE: The correct sequence to transmit is to write first the TXDATA register and then the TXOP one. Only using the DMA, the correct sequence of writing operations is first the TXOP register and then the TXDATA one (if needed).

J1850 BYTE LEVEL PROTOCOL DECODER (Cont'd)

Bit 7:4 = **MLC[3:0]** *Message Length Count*.

Message Length Count bits 3 to 0 are written when the program writes one of the IFR opcodes. Upon detection of the EOD symbol which delineates the body of a frame from the IFR portion of the frame, the received byte counter is compared against the count contained in MLC[3:0]. If they match, then the IFR will be transmitted. If they do not match, then the TRA bit in the ERROR register is set and no transmit attempt occurs.

- While NFL=0, an MCL[3:0] decimal value between 1 and 11 is considered valid. MCL[3:0] values of 12, 13, 14, 15 are considered invalid and will set the Transmit Request Aborted (TRA) bit in the ERROR register.
- While NFL=1, an MCL[3:0] value between 1 and 15 is considered valid.
- For NFL=1 or 0, MCL[3:0] bits are don't care during a MSG or MSG+CRC opcode write.
- If writing an IFR opcode and MCL[3:0]=0000, then the message length count check is ignored (i.e. MLC=Count is disabled), and the IFR is enabled only on a correct CRC and a valid EOD symbol assuming no other error conditions (IFD, IBD, RBRK) appear.

Bit 3 = Reserved.

Bit 2:0 = **OP[2:0]** *Transmit Opcode Select Bits*.

The bits OP[2:0] form the code that the transmitter uses to perform a transmit sequence. The codes are listed in [Table 58](#).

Table 58. Opcode definitions

OP[2:0]	Transmit opcode	Abbreviation
000	No operation or Cancel	CANCEL
001	Send Break Symbol	SBRK
010	Message Byte	MSG
011	Message Byte then append CRC	MSG+CRC
100	In-Frame Response Type 1	IFR1
101	In-Frame Response Type 2	IFR2
110	In-Frame Response Type 3	IFR3
111	IFR Type 3 then append CRC	IFR3+CRC

MSG, Message Byte Opcode.

The Message byte opcode is set when the user program wants to initiate or continue transmitting the body of a message out the VPWO pin.

The body of a message is the string of data bytes following an SOF symbol, but before the first EOD symbol in a frame. If the J1850 bus is in an idle condition when the opcode is written, an SOF symbol is transmitted out the VPWO pin immediately before it transmits the data contained in TXDATA. If the JBLPD is not in idle and the J1850 transmitter has not been locked out by loss of arbitration, then the TXDATA byte is transferred to the serial output shift register for transmission immediately on completion of any previously transmitted data. The final byte of a message string is not transmitted using the MSG opcode (use the MSG+CRC opcode).

Special Conditions for MSG Transmit:

- 1) A MSG cannot be queued on top of an executing IFR3 opcode. If so, then TRA is set, and TDUF will get set because the transmit state machine will be expecting more data, then the inverted CRC is appended to this frame. Also, no message byte will be sent on the next frame.
- 2) If NFL = 0 and an MSG queued without CRC on Received Byte Count for this frame=10 will trigger the TRA to get set, and TDUF will get set because the state machine will be expecting more data and the transmit machine will send the inverted CRC after the byte which is presently transmitting. Also, no message byte will be sent on the next frame.

Caution should be taken when TRA gets set in these cases because the TDUF error sequence may engage before the user program has a chance to rewrite the TXOP register with the correct opcode. If a TDUF error occurs, a subsequent MSG write to the TXOP register will be used as the first byte of the next frame.

J1850 BYTE LEVEL PROTOCOL DECODER (Cont'd)

MSG+CRC, Message byte then append CRC opcode.

The 'Message byte with CRC' opcode is set when the user program wants to transmit a single byte message followed by a CRC byte, or transmit the final byte of a message string followed by a CRC byte.

A single byte message is basically an SOF symbol followed by a single data byte retrieved from TXDATA register followed by the computed CRC byte followed by an EOD symbol. If the J1850 bus is in idle condition when the opcode is written, an SOF symbol is immediately transmitted out the VPWO pin. It then transmits the byte contained in the TXDATA register, then the computed CRC byte is transmitted. VPWO is then set to a passive state. If the J1850 bus is not idle and the J1850 transmitter has not been locked out by loss of arbitration, then the TXDATA byte is transferred to the serial output shift register for transmission immediately on completion of any previously transmitted data. After completion of the TXDATA byte the computed CRC byte is transferred out the VPWO pin and then the VPWO pin is set passive to time an EOD symbol.

Special Conditions for MSG+CRC Transmit:

- 1) A MSG+CRC opcode cannot be queued on top of an executing IFR3 opcode. If so, then TRA is set, and TDUF will get set because the transmit state machine will be expecting more data, then the inverted CRC is appended to this frame. Also, no message byte will be sent on the next frame.
- 2) If NFL=0, a MSG+CRC can only be queued if Received Byte Count for this frame <=10 otherwise the TRA will get set, and TDUF will get set because the state machine will be expecting more data, so the transmit machine will send the inverted CRC after the byte which is presently transmitting. Also, no message byte will be sent on the next frame.

Caution should be taken when TRA gets set in these cases because the TDUF error sequence may engage before the user program has a

chance to rewrite the TXOP register with the correct opcode. If a TDUF error occurs, a subsequent MSG+CRC write to the TXOP register will be used as the first byte of the next frame.

IFR1, In-Frame Response Type 1 opcode.

The In-frame Response Type 1 (IFR 1) opcode is written if the user program wants to transmit a physical address byte (contained in the PADDR register) in response to a message that is currently being received.

The user program decides to set up an IFR1 upon receiving a certain portion of the data byte string of an incoming message. No write of the TXDATA register is required. The IFR1 gets its data byte from the PADDR register.

The JBLPD block will enable the transmission of the IFR1 on these conditions:

- 1) The CRC check is valid (otherwise the CRCE is set)
- 2) The received message length is valid if enabled (otherwise the TRA is set)
- 3) A valid EOD minimum symbol is received (otherwise the IFD may eventually get set due to byte synchronization errors)
- 4) If NFL = 0 & Received Byte Count for this frame <=11 (otherwise TRA is set)
- 5) If not presently executing an MSG, IFR3, opcode (otherwise TRA is set, and TDUF will get set because the transmit state machine will be expecting more data, so the inverted CRC will be appended to this frame)
- 6) If not presently executing an IFR1, IFR2, or IFR3+CRC opcode otherwise TRA is set (but no TDUF)
- 7) If not presently receiving an IFR portion of a frame, otherwise TRA is set.

The IFR1 byte is then attempted according to the procedure described in section "Transmitting a type 1 IFR". Note that if an IFR1 opcode is written, a queued MSG or MSG+CRC is overridden by the IFR1.

J1850 BYTE LEVEL PROTOCOL DECODER (Cont'd)

IFR2, In-Frame Response Type 2 opcode.

The In-frame Response Type 2 (IFR2) opcode is set if the user program wants to transmit a physical address byte (contained in the PADDR register) in response to a message that is currently being received.

The user program decides to set up an IFR2 upon receiving a certain portion of the data byte string of an incoming message. No write of the TXDATA register is required. The IFR gets its data byte from the PADDR register.

The JBLPD block will enable the transmission of the IFR2 on these conditions:

- 1) The CRC check is valid (otherwise the CRCE is set)
- 2) The received message length is valid if enabled (otherwise the TRA is set)
- 3) A valid EOD minimum symbol is received (otherwise the IFD may eventually get set due to byte synchronization errors)
- 4) If NFL = 0 & Received Byte Count for this frame ≤ 11 (otherwise TRA is set)
- 5) If not presently executing an MSG, IFR3, opcode (otherwise TRA is set, and TDUF will get set because the transmit state machine will be expecting more data, so the inverted CRC will be appended to this frame)
- 6) If not presently executing an IFR1, IFR2, or IFR3+CRC opcodes, otherwise TRA is set (but no TDUF)
- 7) If not presently receiving an IFR portion of a frame, otherwise TRA is set.

The IFR byte is then attempted according to the procedure described in section “Transmitting a type 2 IFR”. Note that if an IFR opcode is written, a queued MSG or MSG+CRC is overridden by the IFR2.

IFR3, In-Frame Response Type 3 opcode.

The In-Frame Response Type 3 (IFR3) opcode is set if the user program wants to initiate to transmit or continue to transmit a string of data bytes in response to a message that is currently being re-

ceived.

The IFR3 uses the contents of the TXDATA register for data. The user program decides to set up an IFR3 upon receiving a certain portion of the data byte string of an incoming message. A previous write of the TXDATA register should have occurred.

The JBLPD block will enable the transmission of the first byte of an IFR3 string on these conditions:

- 1) The CRC check is valid (otherwise the CRCE is set)
- 2) The received message length is valid if enabled (otherwise the TRA is set)
- 3) A valid EOD minimum symbol is received (otherwise the IFD may eventually get set due to byte synchronization errors)
- 4) If NFL = 0 & Received Byte Count for this frame ≤ 9 (otherwise TRA is set and inverted CRC is transmitted due to TDUF)
- 5) If not presently executing an MSG opcode (otherwise TRA is set, and TDUF will get set because the transmit state machine will be expecting more data and the inverted CRC will be appended to this frame)
- 6) If not presently executing an IFR1, IFR2, or IFR3+CRC opcode, otherwise TRA is set (but no TDUF)
- 7) If not presently receiving an IFR portion of a frame, otherwise TRA is set.

The IFR3 byte string is then attempted according to the procedure described in section “Transmitting a type 3 IFR”. Note that if an IFR3 opcode is written, a queued MSG or MSG+CRC is overridden by the IFR3.

The next byte(s) in the IFR3 data string shall also be written with the IFR3 opcode except for the last byte in the string which shall be written with the IFR3+CRC opcode. Each IFR3 data byte transmission is accomplished with a TXDATA/TXOP write sequence. The succeeding IFR3 transmit requests will be enabled on conditions 4 and 5 listed above.

J1850 BYTE LEVEL PROTOCOL DECODER (Cont'd)

IFR3+CRC, In-Frame Response Type 3 then append CRC opcode.

The In-frame Response Type 3 then append CRC opcode (IFR3+CRC) is set if the user program wants to either initiate to transmit a single data byte IFR3 followed by a CRC, or transmit the last data byte of an IFR3 string followed by the CRC byte in response to a message that is currently being received.

The IFR3+CRC opcode transmits the contents of the TXDATA register followed by the computed CRC byte. The user program decides to set up an IFR3 upon receiving a certain portion of the data byte string of an incoming message. A previous write of the TXDATA register should have occurred.

The J1850 block will enable the transmission of the first byte of an IFR3 string on these conditions:

- 1) The CRC check is valid (otherwise the CRCE is set)
- 2) The received message length is valid if enabled (otherwise the TRA is set)
- 3) A valid EOD minimum symbol is received (otherwise the IFD may eventually get set due to byte synchronization errors)
- 4) If NFL = 0 & Received Byte Count for this frame <=10 (otherwise TRA is set and inverted CRC is transmitted)
- 5) If not presently executing an MSG opcode (otherwise TRA is set, and TDUF will get set because the transmit state machine will be expecting more data and the inverted CRC will be appended to this frame)
- 6) If not presently executing an IFR1, IFR2 or IFR3+CRC opcodes, otherwise TRA is set (but no TDUF)
- 7) If not presently receiving an IFR portion of a frame, otherwise TRA is set.

The IFR3 byte is attempted according to the procedure described in section "Transmitting a type 3 IFR". The CRC byte is transmitted out on completion of the transmit of the IFR3 byte.

If this opcode sets up the last byte in an IFR3 data string, then the TXDATA register contents shall be transmitted out immediately upon completion of the previous IFR3 data byte followed by the transmit of the CRC byte. In this case the IFR3+CRC is enabled on conditions 4 and 5 listed above. Note that if an IFR3+CRC opcode is written, a queued MSG or MSG+CRC is overridden by the IFR3+CRC.

SBRK, Send Break Symbol.

The SBRK opcode is written to transmit a nominal break (BRK) symbol out the VPWO pin. A Break symbol can be initiated at any time. Once the SBRK opcode is written a BRK symbol of the nominal Tv5 duration will be transmitted out the VPWO pin immediately. To terminate the transmission of an in-progress break symbol the JE bit should be set to a logic zero. An SBRK command is non-maskable, it will override any present transmit operation, and it does not wait for the present transmit to complete. Note that in the 4X mode a SBRK will send a break character for the nominal Tv5 time times four (4 x Tv5) so that all nodes on the bus will recognize the break. A CANCEL opcode does not override a SBRK command.

CANCEL, No Operation or Cancel Pending Transmit.

The Cancel opcode is used by the user program to tell the J1850 transmitter that a previously queued opcode should not be transmitted. The Cancel opcode will set the TRDY bit. If the JBLPD peripheral is presently not transmitting, the Cancel command effectively cancels a pending MSGx or IFRx opcode if one was queued, or it does nothing if no opcode was queued. If the JBLPD peripheral is presently transmitting, then a queued MSGx or IFRx opcode is aborted and the TDUF circuit may take affect.

J1850 BYTE LEVEL PROTOCOL DECODER (Cont'd)

JBLPD SYSTEM FREQUENCY SELECTION REGISTER (CLKSEL)

R244- Read/Write

Register Page: 23

Reset Value: 0000 0000 (00h)

7							0
4X	-	FREQ5	FREQ4	FREQ3	FREQ2	FREQ1	FREQ0

Bit 7 = **4X Diagnostic Four Times Mode.**

This bit is set when the J1850 clock rate is chosen four times faster than the standard requests, to force the BREAK symbol (nominally 300 μs long) and the Transmitter Timeout Time (nominally 1 ms) at their nominal durations.

When the user want to use a 4 times faster J1850 clock rate, the new prescaler factor should be stored in the FREQ[5:0] bits and the 4X bit must be set with the same instruction. In the same way, to exit from the mode, FREQ[5:0] and 4X bits must be placed at the previous value with the same instruction.

0: Diagnostic Four Times Mode disabled

1: Diagnostic Four Times Mode enabled

Note: Setting this bit, the prescaler factor is not automatically divided by four. The user must adapt the value stored in FREQ[5:0] bits by software.

Note: The customer should take care using this mode when the MCU internal frequency is less than 4MHz.

Bit 6 = Reserved.

Bit 5:0 = **FREQ[5:0] Internal Frequency Selectors.**

These 6 bits must be programmed depending on the internal frequency of the device. The formula that must be used is the following one:

MCU Int. Freq.= 1MHz * (FREQ[5:0] + 1).

Note: To obtain a correct operation of the peripheral, the internal frequency of the MCU (INTCLK) must be an integer multiple of 1MHz and the cor-

rect value must be written in the register. So an internal frequency less than 1MHz is not allowed.

Note: If the MCU internal clock frequency is lower than 1MHz, the peripheral is not able to work correctly. If a frequency lower than 1MHz is used, the user program must disable the peripheral.

Note: When the clock prescaler factor or the MCU internal frequency is changed, the peripheral could lose the synchronization with the J1850 bus.

JBLPD CONTROL REGISTER (CONTROL)

R245- Read/Write

Register Page: 23

Reset Value: 0100 0000 (40h)

7							0
JE	JDIS	NFL	JDLY4	JDLY3	JDLY2	JDLY1	JDLY0

The CONTROL register is an eight bit read/write register which contains JBLPD control information. Reads of this register return the last written data.

Bit 7 = **JE JBLPD Enable.**

The JBLPD block enable bit (JE) enables and disables the transmitter and receiver to the VPWO and VPWI pins respectively. When the JBLPD peripheral is disabled the VPWO pin is in its passive state and information coming in the VPWI pin is ignored. When the JBLPD block is enabled, the transmitter and receiver function normally. Note that queued transmits are aborted when JE is cleared. JE is cleared on reset, by software and setting the JDIS bit.

0: The peripheral is disabled

1: The peripheral is enabled

Note: It is not possible to reset the JDIS bit and to set the JE bit with the same instruction. The correct sequence is to first reset the JDIS bit and then set the JE bit with another instruction.

J1850 BYTE LEVEL PROTOCOL DECODER (Cont'd)

Bit 6 = **JDIS** *Peripheral clock frozen.*

When this bit is set by software, the peripheral is stopped and the bus is not decoded anymore. A reset of the bit restarts the internal state machines as after a MCU reset. The JDIS bit is set on MCU reset.

0: The peripheral clock is running

1: The peripheral clock is stopped

Note: When the JDIS bit is set, the STATUS register, the ERROR register, the IMR register and the TEOBP and REOBP bits of the PRLR register are forced into their reset value.

Note: It is not possible to reset the JDIS bit and to set the JE bit with the same instruction. The correct sequence is to first reset the JDIS bit and then set the JE bit with another instruction.

Bit 5 = **NFL** *No Frame Length Check*

The NFL bit is used to enable/disable the J1850 requirement of 12 bytes maximum per frame limit. The SAE J1850 standard states that a maximum of 12 bytes (including CRCs and IFRs) can be on the J1850 between a start of frame symbol (SOF) and an end of frame symbol (EOF). If this condition is violated, then the JBLPD peripheral gets an Invalid Frame Detect (IFD) and the sleep mode ensues until a valid EOFM is detected. If the valid frame check is disabled (NFL=1), then no limits are imposed on the number of data bytes which can be sent or received on the bus between an SOF and an EOF. The default upon reset is for the frame checking to be enabled.

The NFL bit is cleared on reset

0: Twelve bytes frame length check enabled

1: Twelve bytes frame length check disabled

Bit 4:0 = **JDLY[4:0]** *JBLPD Transceiver External Loop Delay Selector.*

These five bits are used to select the nominal external loop time delay which normally occurs when the peripheral is connected and transmitting in a J1850 bus system. The external loop delay is defined as the time between when the VPWO is set to a certain level to when the VPWI recognizes the corresponding (inverted) edge on its input. Refer to "Transmit Opcode Queuing" section and the SAE-J1850 standard for information on how the external loop delay is used in timing transmitted symbols.

The allowed values are integer values between 0 μ s and 31 μ s.

JBLPD PHYSICAL ADDRESS REGISTER (PADDR)

R246- Read/Write

Register Page: 23

Reset Value: xxxx xxxx (xxh)

7							0
ADR7	ADR6	ADR5	ADR4	ADR3	ADR2	ADR1	ADR0

The PADDR is an eight bit read/write register which contains the physical address of the JBLPD peripheral. During initialization the user program will write the PADDR register with its physical address. The Physical Address is used during in-frame response types 1 and 2 to acknowledge the receipt of a message. The JBLPD peripheral will transmit the contents of the PADDR register for type 1 or 2 IFRs as defined by the TXOP register. This register is undefined on reset.

J1850 BYTE LEVEL PROTOCOL DECODER (Cont'd)

JBLPD ERROR REGISTER (ERROR)

R247- Read only

Register Page: 23

Reset Value: 0000 0000 (00h)

7								0
TTO	TDUF	RDOF	TRA	RBRK	CRCE	IFD	IBD	

ERROR is an eight bit read only register indicating error conditions that may arise on the VPWO and VPWI pins. A read of the ERROR register clears all bits (except for TTO and possibly the RBRK bit) which were set at the time of the read. The register is cleared after the MCU reset, while the CONTROL.JE bit is reset, or while the CONTROL.JDIS bit is set.

All error conditions that can be read in the ERROR register need to have redundant ERROR indicator flags because:

- With JE set, the TDUF, RDOF, TRA, CRCE, IFD, & IBD bits in the ERROR register can only be cleared by reading the register.
- The TTO bit can only be cleared by clearing the JE bit.
- The RBRK bit can only be cleared by reading the ERROR register after the break condition has disappeared.

Error condition indicator flags associated with the error condition are cleared when the error condition ends. Since error conditions may alter the actions of the transmitter and receiver, the error condition indicators must remain set throughout the error condition. All error conditions, including the RBRK condition, are events that get set during a particular clock cycle of the prescaled clock of the peripheral. The IFD, IBD, RBRK, and CRCE error conditions are then cleared when a valid EOF symbol is detected from the VPWI pin. The TRA error condition is a singular event that sets the corresponding ERROR register bit, but this error itself causes no other actions.

Bit 7 = **TTO** *Transmitter Timeout Flag*

The TTO bit is set when the VPWO pin has been in a logic one (or active) state for longer than 1 ms. This flag is the output of a diagnostic circuit based on the prescaled system clock input. If the 4X bit is not set, the TTO will trip if the VPWO is constantly active for 1000 prescaled clock cycles. If the 4X bit

is set, then the TTO will timeout at 4000 prescaled clock cycles. When the TTO flag is set then the diagnostic circuit will disable the VPWO signal, and disable the JBLPD peripheral. The user program must then clear the JE bit to remove the TTO error. It can then retry the block by setting the JE bit again.

The TTO bit can be used to determine if the external J1850 bus is shorted low. Since the transmitter looks for proper edges returned at the VPWI pin for its timing, a lack of edges seen at VPWI when trying to transmit (assuming the RBRK does not get set) would indicate a constant low condition. The user program can take appropriate actions to test the J1850 bus circuit when a TTO occurs. Note that a transmit attempt must occur to detect a bus shorted low condition.

The TTO bit is cleared while the CONTROL.JE bit is reset or while the CONTROL.JDIS bit is set. TTO is cleared on reset.

- 0: VPWO line at 1 for less than 1 ms
- 1: VPWO line at 1 for longer than 1 ms

Bit 6 = **TDUF** *Transmitter Data Underflow.*

The TDUF will be set to a logic one if the transmitter expects more information to be transmitted, but a TXOP write has not occurred in time (by the end of transmission of the last bit).

The transmitter knows to expect more information from the user program when transmitting messages or type 3 IFRs only. If an opcode is written to TXOP that does not include appending a CRC byte, then the JBLPD peripheral assumes more data is to be written. When the JBLPD peripheral has shifted out the data byte it must have the next data byte in time to place it directly next to it. If the user program does not place new data in the TXDATA register and write the TXOP register with a proper opcode, then the CRC byte which is being kept tabulated by the transmitter is logically inverted and transmitted out the VPWO pin. This will ensure that listeners will detect this message as an error. In this case the TDUF bit is set to a logic one.

TDUF is cleared by reading the ERROR register with TDUF set. TDUF is also cleared on reset, while the CONTROL.JE bit is reset or while the CONTROL.JDIS bit is set.

- 0: No transmitter data underflow condition occurred
- 1: Transmitter data underflow condition occurred

J1850 BYTE LEVEL PROTOCOL DECODER (Cont'd)

Bit 5 = RDOF Receiver Data Overflow

The RDOF gets set to a logic one if the data in the RXDATA register has not been read and new data is ready to be transferred to the RXDATA register. The old RXDATA information is lost since it is overwritten with new data.

RDOF is cleared by reading the ERROR register with RDOF set, while the CONTROL.JE bit is reset or while the CONTROL.JDIS bit is set, or on reset.
 0: No receiver data overflow condition occurred
 1: Receiver data overflow condition occurred

Bit 4 = TRA Transmit Request Aborted

The TRA gets set to a logic one if a transmit opcode is aborted by the JBLPD state machine. Many conditions may cause a TRA. They are explained in the transmit opcode section. If the TRA bit gets set after a TXOP write, then a transmit is not attempted, and the TRDY bit is not cleared.

If a TRA error condition occurs, then the requested transmit is aborted, and the JBLPD peripheral takes appropriate measures as described under the TXOP register section.

TRA is cleared on reset, while the CONTROL.JE bit is reset or while the CONTROL.JDIS bit is set.
 0: No transmission request aborted
 1: Transmission request aborted

Bit 3 = RBRK Received Break Symbol Flag

The RBRK gets set to a logic one if a valid break (BRK) symbol is detected from the filtered VPWI pin. A Break received from the J1850 bus will cancel queued transmits of all types. The RBRK bit remains set as long as the break character is detected from the VPWI. Reads of the ERROR register will not clear the RBRK bit as long as a break character is being received. Once the break character is gone, a final read of the ERROR register clears this bit.

An RBRK error occurs once for a frame if it is received during a frame. Afterwards, the receiver is disabled from receiving information (other than the break) until an EOFM symbol is received.

RBRK bit is cleared on reset, while the CONTROL.JE bit is reset or while the CONTROL.JDIS bit is set.

The RBRK bit can be used to detect J1850 bus shorted high conditions. If RBRK is read as a logic high multiple times before an EOFM occurs, then a possible bus shorted high condition exists. The user program can take appropriate measures to test the bus if this condition occurs. Note that this bit does not necessarily clear when ERROR is read.

0: No valid Break symbol received
 1: Valid Break symbol received

Bit 2 = CRCE Cyclic Redundancy Check Error

The receiver section always keeps a running tab of the CRC of all data bytes received from the VPWI since the last EOD symbol. The CRC check is performed when a valid EOD symbol is received both after a message string (subsequent to an SOF symbol) and after an IFR3 string (subsequent to an NB0 symbol). If the received CRC check fails, then the CRCE bit is set to a logic one. CRC errors are inhibited if the JBLPD peripheral is in the "sleep or filter and NOT presently transmitting" mode. A CRC error occurs once for a frame. Afterwards, the receiver is disabled until an EOFM symbol is received and queued transmits for the present frame are cancelled (but the TRA bit is not set). CRCE is cleared when ERROR is read. It is also cleared while the CONTROL.JE bit is reset or while the CONTROL.JDIS bit is set, or on reset.

0: No CRC error detected
 1: CRC error detected

Bit 1 = IFD Invalid Frame Detect

The IFD bit gets set when the following conditions are detected from the filtered VPWI pin:

- An SOF symbol is received after an EOD minimum, but before an EOF minimum.
- An SOF symbol is received when expecting data bits.
- If NFL = 0 and a message frame greater than 12 bytes (i.e. 12 bytes plus one bit) has been received in one frame.
- An EOD minimum time has elapsed when data bits are expected.
- A logic 0 or 1 symbol is received (active for Tv1 or Tv2) when an SOF was expected.
- The second EODM symbol received in a frame is NOT followed directly by an EOFM symbol.

IFD errors are inhibited if the JBLPD peripheral is in the "sleep or filter and NOT presently transmitting" mode. An IFD error occurs once for a frame. Afterwards, the receiver is disabled until an EOFM symbol is received, and queued transmits for the present frame are cancelled (but the TRA bit is not set). IFD is cleared when ERROR is read. It is also cleared while the CONTROL.JE bit is reset or while the CONTROL.JDIS bit is set or on reset.

0: No invalid frame detected
 1: Invalid frame detected

J1850 BYTE LEVEL PROTOCOL DECODER (Cont'd)

Bit 0 = **IBD** *Invalid Bit Detect*.

The IBD bit gets set whenever the receiver detects that the filtered VPWI pin was not fixed in a state long enough to reach the minimum valid symbol time of Tv1 (or 35 μs). Any timing event less than 35 μs (and, of course, > 7 μs since the VPWI digital filter will not allow pulses less than this through its filter) is considered as noise and sets the IBD accordingly. At this point the JBLPD peripheral will cease transmitting and receiving any information until a valid EOF symbol is received.

IBD errors are inhibited if the JBLPD peripheral is in the “sleep or filter and NOT presently transmitting” mode. An IBD error occurs once for a frame. Afterwards, the receiver is disabled until an EOFM symbol is received, and queued transmits for the present frame are cancelled (but the TRA bit is not set).

IBD is cleared when ERROR is read. Note that if an invalid bit is detected during a bus idle condition, the IBD flag gets set and a new EOFmin must be seen after the invalid bit before commencing to receive again. IBD is also cleared while the CONTROL.JE bit is reset or while the CONTROL.JDIS bit is set and on reset.

0: No invalid bit detected

1: Invalid bit detected

JBLPD INTERRUPT VECTOR REGISTER (IVR)

R248- Read/Write (except bits 2:1)

Register Page: 23

Reset Value: xxxx xxx0 (xxh)

7							0
V7	V6	V5	V4	V3	EV2	EV1	-

Bit 7:3 = **V[7:3]** *Interrupt Vector Base Address*.
User programmable interrupt vector bits.

Bit 2:1 = **EV[2:1]** *Encoded Interrupt Source (Read Only)*.

EV2 and EV1 are set by hardware according to the interrupt source, given in [Table 59](#) (refer to the Status register bits description about the explanation of the meaning of the interrupt sources)

Table 59. Interrupt Sources

EV2	EV1	Interrupt Sources
0	0	ERROR, TLA
0	1	EODM, EOFM
1	0	RDRF, REOB
1	1	TRDY, TEOB

Bit 0 = *Reserved*.

JBLPD PRIORITY LEVEL REGISTER (PRLR)

R249- Read/Write

Register Page: 23

Reset Value: 0001 0000 (10h)

7							0
PRL2	PRL1	PRL0	SLP	-	-	REOBP	TEOBP

Bit 7:5 = **PRL[2:0]** *Priority level bits*

The priority with respect to the other peripherals and the CPU is encoded with these three bits. The value of “0” has the highest priority, the value “7” has no priority. After the setting of this priority level, the priorities between the different Interrupt sources and DMA of the JBLPD peripheral is hardware defined (refer to the “Status register” bits description, the “Interrupts Management” and the section about the explanation of the meaning of the interrupt sources).

Depending on the value of the OPTIONS.DMASUSP bit, the DMA transfers can or cannot be suspended by an ERROR or TLA event. Refer to the description of DMASUSP bit.

Table 60. Internal Interrupt and DMA Priorities without DMA suspend mode

Priority Level	Event Sources
Higher Priority	TX-DMA
	RX-DMA
	ERROR, TLA
	EODM, EOFM
	RDRF, REOB
Lower Priority	TRDY, TEOB

Table 61. Internal Interrupt and DMA Priorities with DMA suspend mode

Priority Level	Event Sources
Higher Priority	ERROR, TLA
	TX-DMA
	RX-DMA
	EODM, EOFM
	RDRF, REOB
Lower Priority	TRDY, TEOB

J1850 BYTE LEVEL PROTOCOL DECODER (Cont'd)

Bit 4 = **SLP** *Receiver Sleep Mode*.

The SLP bit is written to one when the user program does not want to receive any data from the JBLPD VPWI pin until an EOFM symbol occurs. This mode is usually set when a message is received that the user does not require - including messages that the JBLPD is transmitting. If the JBLPD is not transmitting and is in Sleep mode, no data is transferred to the RXDATA register, the RDRF flag does not get set, and errors associated with received data (RDOF, CRCE, IFD, IBD) do not get set. Also, the EODM flag will not get set.

If the JBLPD peripheral is transmitting and is in sleep mode, no data is transferred to the RXDATA register, the RDRF flag does not get set and the RDOF error flag is inhibited. The CRCE, IFD, and IBD flags, however, will NOT be inhibited while transmitting in sleep mode.

The SLP bit cannot be written to zero by the user program. The SLP bit is set on reset or TTO getting set, and it will stay set upon JE getting set until an EOFM symbol is received.

The SLP gets cleared on reception of an EOF or a Break symbol. SLP is set while CONTROL.JE is reset and while CONTROL.JDIS is set.

0: The JBLPD is not in Sleep Mode

1: The JBLPD is in Sleep Mode

Bit 3:2 = *Reserved*.

Bit 1 = **REOP** *Receiver DMA End Of Block Pending*.

This bit is set after a receiver DMA cycle to mark the end of a block of data. An interrupt request is performed if the RDRF_M bit of the IMR register is set. REOBP should be reset by software in order to avoid undesired interrupt routines, especially in initialisation routine (after reset) and after entering the End Of Block interrupt routine.

Writing "0" in this bit will cancel the interrupt request.

This bit is reset when the CONTROL.JDIS bit is set at least for 6 MCU clock cycles (3 NOPs).

Note: When the REOBP flag is set, the RXD_M bit is reset by hardware.

Note: REOBP can only be written to "0".

Bit 0 = **TEOP** *Transmitter DMA End Of Block Pending*.

This bit is set after a transmitter DMA cycle to mark

the end of a block of data. An interrupt request is performed if the TRDY_M bit of the IMR register is set. TEOBP should be reset by software in order to avoid undesired interrupt routines, especially in initialisation routine (after reset) and after entering the End Of Block interrupt routine.

Writing "0" in this bit will cancel the interrupt request.

This bit is reset when the CONTROL.JDIS bit is set at least for 6 MCU clock cycles (3 NOPs).

Note: When the TEOBP flag is set, the TXD_M bit is reset by hardware.

Note: TEOBP can only be written to "0".

JBLPD INTERRUPT MASK REGISTER (IMR)

R250 - Read/Write

Register Page: 23

Reset Value: 0000 0000 (00h)

7							0
ERR_ M	TRDY_ M	RDRF_ M	TLA_ M	RXD_ M	EODM_ M	EOFM_ M	TXD_ M

To enable an interrupt source to produce an interrupt request, the related mask bit must be set. When these bits are reset, the related Interrupt Pending bit can not generate an interrupt.

Note: This register is forced to its reset value if the CONTROL.JDIS bit is set at least for 6 clock cycles (3 NOPs). If the JDIS bit is set for a shorter time, the bits could be reset or not reset.

Bit 7 = **ERR_M** *Error Interrupt Mask bit*.

This bit enables the "error" interrupt source to generate an interrupt request.

This bit is reset if the CONTROL.JDIS bit is set at least for 6 clock cycles (3 NOPs).

0: Error interrupt source masked

1: Error interrupt source un-masked

Bit 6 = **TRDY_M** *Transmit Ready Interrupt Mask bit*.

This bit enables the "transmit ready" interrupt source to generate an interrupt request.

This bit is reset if the CONTROL.JDIS bit is set at least for 6 clock cycles (3 NOPs).

0: TRDY interrupt source masked

1: TRDY interrupt source un-masked

J1850 BYTE LEVEL PROTOCOL DECODER (Cont'd)

Bit 5 = **RDRF_M** *Receive Data Register Full Interrupt Mask bit.*

This bit enables the “receive data register full” interrupt source to generate an interrupt request.

This bit is reset if the CONTROL.JDIS bit is set at least for 6 clock cycles (3 NOPs).

0: RDRF interrupt source masked

1: RDRF interrupt source un-masked

Bit 4 = **TLA_M** *Transmitter Lost Arbitration Interrupt Mask bit.*

This bit enables the “transmitter lost arbitration” interrupt source to generate an interrupt request.

This bit is reset if the CONTROL.JDIS bit is set at least for 6 clock cycles (3 NOPs).

0: TLA interrupt source masked

1: TLA interrupt source un-masked

Bit 3 = **RXD_M** *Receiver DMA Mask bit.*

If this bit is “0” no receiver DMA request will be generated, and the RDRF bit, in the Status Register (STATUS), can request an interrupt. If RXD_M bit is set to “1” then the RDRF bit can request a DMA transfer. RXD_M is reset by hardware when the transaction counter value decrements to zero, that is when a Receiver End Of Block condition occurs (REOBP flag set).

This bit is reset if the CONTROL.JDIS bit is set at least for 6 clock cycles (3 NOPs).

0: Receiver DMA disabled

1: Receiver DMA enabled

Bit 2 = **EODM_M** *End of Data Minimum Interrupt Mask bit.*

This bit enables the “end of data minimum” interrupt source to generate an interrupt request.

This bit is reset if the CONTROL.JDIS bit is set at least for 6 clock cycles (3 NOPs).

0: EODM interrupt source mask

1: EODM interrupt source un-masked

Bit 1 = **EOFM_M** *End of Frame Minimum Interrupt Mask bit.*

This bit enables the “end of frame minimum” interrupt source to generate an interrupt request.

This bit is reset if the CONTROL.JDIS bit is set at least for 6 clock cycles (3 NOPs).

0: EOFM interrupt source masked

1: EOFM interrupt source un-masked

Bit 0 = **TXD_M** *Transmitter DMA Mask bit.*

If this bit is “0” no transmitter DMA request will be generated, and the TRDY bit, in the Status Register (STATUS), can request an interrupt. If TXD_M bit is set to “1” then the TRDY bit can request a DMA transfer. TXD_M is reset by hardware when the transaction counter value decrements to zero, that is when a Transmitter End Of Block condition occurs (TEOBP flag set).

This bit is reset if the CONTROL.JDIS bit is set at least for 6 clock cycles (3 NOPs).

0: Transmitter DMA disabled

1: Transmitter DMA enabled

JBLPD OPTIONS AND REGISTER GROUPS SELECTION REGISTER (OPTIONS)

R251- Read/Write

Register Page: 23

Reset Value: 0000 0000 (00h)

7							0
INPOL	NBSYMS	DMASUSP	LOOPB	RSEL3	RSEL2	RSEL1	RSEL0

Bit 7 = **INPOL** *VPWI Input Polarity Selector.*

This bit allows the selection of the polarity of the RX signal coming from the transceivers. Depending on the specific transceiver, the RX signal is inverted or not inverted respect the VPWO and the J1850 bus line.

0: VPWI input is inverted by the transceiver with respect to the J1850 line.

1: VPWI input is not inverted by the transceiver with respect to the J1850 line.

Bit 6 = **NBSYMS** *NB Symbol Form Selector.*

This bit allows the selection of the form of the Normalization Bits (NB0/NB1).

0: NB0 active long symbol (Tv2), NB1 active short symbol (Tv1)

1: NB0 active short symbol (Tv1), NB1 active long symbol (Tv2)

J1850 BYTE LEVEL PROTOCOL DECODER (Cont'd)

Bit 5 = **DMASUSP** *DMA Suspended Selector*.

If this bit is "0", JBLPD DMA has higher priority with respect to the Interrupts of the peripheral. DMA is performed even if an interrupt request is already scheduled or if the relative interrupt routine is in execution.

If the bit is "1", while the ERROR or TLA flag of the STATUS register are set, the DMA transfers are suspended. As soon as the flags are reset, the DMA transfers can be performed.

0: DMA not suspended

1: DMA suspended

Note: This bit has effect only on the priorities of the JBLPD peripheral.

Bit 4 = **LOOPB** *Local Loopback Selector*.

This bit allows the Local Loopback mode. When this mode is enabled (LOOPB=1), the VPWO output of the peripheral is sent to the VPWI input without inversions whereas the VPWO output line of the MCU is placed in the passive state. Moreover the VPWI input of the MCU is ignored by the peripheral. (Refer to [Figure 138](#)).

0: Local Loopback disabled

1: Local Loopback enabled

Note: When the LOOPB bit is set, **also the INPOL bit must be set** to obtain the correct management of the polarity.

Bit 3:0 = **RSEL[3:0]** *Registers Group Selection bits*.

These four bits are used to select one of the 9 groups of registers, each one composed of four registers that are stacked at the addresses from R252 (FCh) to R255 (FFh) of this register page (23). Unless the wanted registers group is already selected, to address a specific registers group, these bits must be correctly written.

This feature allows that 36 registers (4 DMA registers - RDADR, RDCPR, TDAPR, TDCPR - and 32 Message Filtering Registers - FREG[0:31]) are mapped using only 4 registers (here called Current Registers - CREG[3:0]).

Since the Message Filtering Registers (FREG[0:31]) are seldom read or written, it is suggested to always reset the RSEL[3:0] bits after accessing the FREG[0:31] registers. In this way the DMA registers are the current registers.

J1850 BYTE LEVEL PROTOCOL DECODER (Cont'd)

JBLPD CURRENT REGISTER 0 (CREG0)

R252- Read/Write
 Register Page: 23
 Reset Value: xxxx xxxx (xxh)

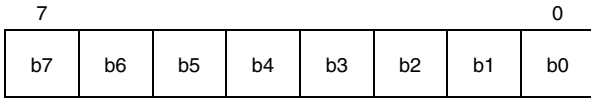

Depending on the RSEL[3:0] value of the OP-TIONS register, this register is one of the following stacked registers: RDAPR, FREG0, FREG4, FREG8, FREG12, FREG16, FREG20, FREG24, FREG28.

JBLPD CURRENT REGISTER 2 (CREG2)

R254- Read/Write
 Register Page: 23
 Reset Value: xxxx xxxx (xxh)

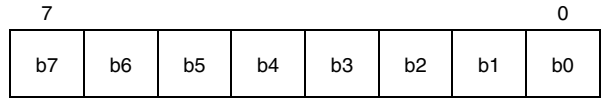

Depending on the RSEL[3:0] value of the OP-TIONS register, this register is one of the following stacked registers: TDAPR, FREG2, FREG6, FREG10, FREG14, FREG18, FREG22, FREG26, FREG30.

JBLPD CURRENT REGISTER 1 (CREG1)

R253 - Read/Write
 Register Page: 23
 Reset Value: xxxx xxxx (xxh)

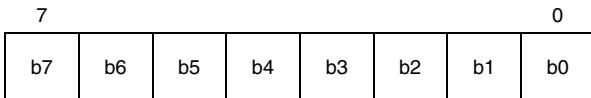

Depending on the RSEL[3:0] value of the OP-TIONS register, this register is one of the following stacked registers: RDCPR, FREG1, FREG5, FREG9, FREG13, FREG17, FREG21, FREG25, FREG29.

JBLPD CURRENT REGISTER 3 (CREG3)

R255- Read/Write
 Register Page: 23
 Reset Value: xxxx xxxx (xxh)

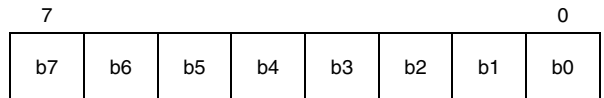

Depending on the RSEL[3:0] value of the OP-TIONS register, this register is one of the following stacked registers: TDCPR, FREG3, FREG7, FREG11, FREG15, FREG19, FREG23, FREG27, FREG31.

Table 62. Stacked registers map

RSEL[3:0] Current Registers	0000b	1000b	1001b	1010b	1011b	1100b	1101b	1110b	1111b
CREG0	RDAPR	FREG0	FREG4	FREG8	FREG12	FREG16	FREG20	FREG24	FREG28
CREG1	RDCPR	FREG1	FREG5	FREG9	FREG13	FREG17	FREG21	FREG25	FREG29
CREG2	TDAPR	FREG2	FREG6	FREG10	FREG14	FREG18	FREG22	FREG26	FREG30
CREG3	TDCPR	FREG3	FREG7	FREG11	FREG15	FREG19	FREG23	FREG27	FREG31

J1850 BYTE LEVEL PROTOCOL DECODER (Cont'd)

10.9.7.2 Stacked Registers

See the description of the OPTIONS register to obtain more information on the map of the registers of this section.

JBLPD RECEIVER DMA ADDRESS POINTER REGISTER (RDAPR)

R252 - RSEL[3:0]=0000b

Register Page: 23

Reset Value: xxxx xxxx (xxh)

7							0
RA7	RA6	RA5	RA4	RA3	RA2	RA1	PS

To select this register, the RSEL[3:0] bits of the OPTIONS register must be reset

Bit 7:1 = **RA[7:1] Receiver DMA Address Pointer.** RDAPR contains the address of the pointer (in the Register File) of the Receiver DMA data source when the DMA between the peripheral and the Memory Space is selected. Otherwise, when the DMA between the peripheral and Register File is selected, this register has no meaning.

See Section 10.9.6.2 for more details on the use of this register.

Bit 0 = **PS Memory Segment Pointer Selector.** This bit is set and cleared by software. It is only meaningful if RDCPR.RF/MEM = 1.

- 0: The ISR register is used to extend the address of data received by DMA (see MMU chapter)
- 1: The DMASR register is used to extend the address of data received by DMA (see MMU chapter)

JBLPD RECEIVER DMA TRANSACTION COUNTER REGISTER (RDCPR)

R253 - RSEL[3:0]=0000b

Register Page: 23

Reset Value: xxxx xxxx (xxh)

7							0
RC7	RC6	RC5	RC4	RC3	RC2	RC1	RF/MEM

To select this register, the RSEL[3:0] bits of the OPTIONS register must be reset

Bit 7:1 = **RC[7:1] Receiver DMA Counter Pointer.** RDCPR contains the address of the pointer (in the

Register File) of the DMA receiver transaction counter when the DMA between Peripheral and Memory Space is selected. Otherwise, if the DMA between Peripheral and Register File is selected, this register points to a pair of registers that are used as DMA Address register and DMA Transaction Counter.

See Section 10.9.6.1 and Section 10.9.6.2 for more details on the use of this register.

Bit 0 = **RF/MEM Receiver Register File/Memory Selector.**

If this bit is set to "1", then the Register File will be selected as Destination, otherwise the Memory space will be used.

- 0: Receiver DMA with Memory space
- 1: Receiver DMA with Register File

JBLPD TRANSMITTER DMA ADDRESS POINTER REGISTER (TDAPR)

R254 - RSEL[3:0]=0000b

Register Page: 23

Reset Value: xxxx xxxx (xxh)

7							0
TA7	TA6	TA5	TA4	TA3	TA2	TA1	PS

To select this register, the RSEL[3:0] bits of the OPTIONS register must be reset

Bit 7:1 = **TA[7:1] Transmitter DMA Address Pointer.**

TDAPR contains the address of the pointer (in the Register File) of the Transmitter DMA data source when the DMA between the Memory Space and the peripheral is selected. Otherwise, when the DMA between Register File and the peripheral is selected, this register has no meaning.

See Section 10.9.6.2 for more details on the use of this register.

Bit 0 = **PS Memory Segment Pointer Selector.** This bit is set and cleared by software. It is only meaningful if TDCPR.RF/MEM = 1.

- 0: The ISR register is used to extend the address of data transmitted by DMA (see MMU chapter)
- 1: The DMASR register is used to extend the address of data transmitted by DMA (see MMU chapter)

J1850 BYTE LEVEL PROTOCOL DECODER (Cont'd)

JBLPD TRANSMITTER DMA TRANSACTION COUNTER REGISTER (TDCPR)

R255 - RSEL[3:0]=0000b

Register Page: 23

Reset Value: xxxx xxxx (xxh)

7							0
TC7	TC6	TC5	TC4	TC3	TC2	TC1	RF/MEM

To select this register, the RSEL[3:0] bits of the OPTIONS register must be reset

Bit 7:1 = **TC[7:1]** Transmitter DMA Counter Pointer.

RDCPR contains the address of the pointer (in the Register File) of the DMA transmitter transaction counter when the DMA between Memory Space and peripheral is selected. Otherwise, if the DMA between Register File and peripheral is selected, this register points to a pair of registers that are used as DMA Address register and DMA Transaction Counter.

See [Section 10.9.6.1](#) and [Section 10.9.6.2](#) for more details on the use of this register.

Bit 0 = **RF/MEM** Transmitter Register File/Memory Selector.

If this bit is set to "1", then the Register File will be selected as Destination, otherwise the Memory space will be used.

0: Transmitter DMA with Memory space

1: Transmitter DMA with Register File

JBLPD MESSAGE FILTERING REGISTERS (FREG[0:31])

R252/R253/R254/R255 - RSEL[3]=1

Register Page: 23

Reset Value: xxxx xxxx (xxh)

Register	7						0	
FREG0	F_07	F_06	F_05	F_04	F_03	F_02	F_01	F_00
FREG1	F_0F	F_0E	F_0D	F_0C	F_0B	F_0A	F_09	F_08
FREG2	F_17	F_16	F_15	F_14	F_13	F_12	F_11	F_10
FREG3	F_1F	F_1E	F_1D	F_1C	F_1B	F_1A	F_19	F_18
FREG4	F_27	F_26	F_25	F_24	F_23	F_22	F_21	F_20
FREG5	F_2F	F_2E	F_2D	F_2C	F_2B	F_2A	F_29	F_28
FREG6	F_37	F_36	F_35	F_34	F_33	F_32	F_31	F_30
FREG7	F_3F	F_3E	F_3D	F_3C	F_3B	F_3A	F_39	F_38
FREG8	F_47	F_46	F_45	F_44	F_43	F_42	F_41	F_40
FREG9	F_4F	F_4E	F_4D	F_4C	F_4B	F_4A	F_49	F_48
FREG10	F_57	F_56	F_55	F_54	F_53	F_52	F_51	F_50
FREG11	F_5F	F_5E	F_5D	F_5C	F_5B	F_5A	F_59	F_58
FREG12	F_67	F_66	F_65	F_64	F_63	F_62	F_61	F_60
FREG13	F_6F	F_6E	F_6D	F_6C	F_6B	F_6A	F_69	F_68
FREG14	F_77	F_76	F_75	F_74	F_73	F_72	F_71	F_70
FREG15	F_7F	F_7E	F_7D	F_7C	F_7B	F_7A	F_79	F_78
FREG16	F_87	F_86	F_85	F_84	F_83	F_82	F_81	F_80
FREG17	F_8F	F_8E	F_8D	F_8C	F_8B	F_8A	F_89	F_88
FREG18	F_97	F_96	F_95	F_94	F_93	F_92	F_91	F_90
FREG19	F_9F	F_9E	F_9D	F_9C	F_9B	F_9A	F_99	F_98
FREG20	F_A7	F_A6	F_A5	F_A4	F_A3	F_A2	F_A1	F_A0
FREG21	F_AF	F_AE	F_AD	F_AC	F_AB	F_AA	F_A9	F_A8
FREG22	F_B7	F_B6	F_B5	F_B4	F_B3	F_B2	F_B1	F_B0
FREG23	F_BF	F_BE	F_BD	F_BC	F_BB	F_BA	F_B9	F_B8
FREG24	F_C7	F_C6	F_C5	F_C4	F_C3	F_C2	F_C1	F_C0
FREG25	F_CF	F_CE	F_CD	F_CC	F_CB	F_CA	F_C9	F_C8
FREG26	F_D7	F_D6	F_D5	F_D4	F_D3	F_D2	F_D1	F_D0
FREG27	F_DF	F_DE	F_DD	F_DC	F_DB	F_DA	F_D9	F_D8
FREG28	F_E7	F_E6	F_E5	F_E4	F_E3	F_E2	F_E1	F_E0
FREG29	F_EF	F_EE	F_ED	F_EC	F_EB	F_EA	F_E9	F_E8
FREG30	F_F7	F_F6	F_F5	F_F4	F_F3	F_F2	F_F1	F_F0
FREG31	F_FF	F_FE	F_FD	F_FC	F_FB	F_FA	F_F9	F_F8

J1850 BYTE LEVEL PROTOCOL DECODER (Cont'd)

These registers are structured in eight groups of four registers. The user can gain access to these registers programming the RSEL[2:0] bits of the OPTIONS register while the RSEL[3] bit of the same register must be placed at 1. In this way the user can select the group where the registers that he/she wants to use are placed. See the description of OPTIONS register for the correspondence between registers and the values of RSEL[2:0] bits (See [Table 62](#)).

From the functional point of view, the FREG[0]-FREG[31] registers can be seen as an array of 256 bits involved in the J1850 received message filtering system.

The first byte received in a frame (following a valid received SOF character) is an Identifier (I.D.) byte. It is used by the JBLPD peripheral as the address of the 256 bits array.

If the bit of the array correspondent to the I.D. byte is set, then the byte is transferred to the RXDATA

register and the RDRF flag is set. Also, every other data byte received in this frame is transferred to the RXDATA register unless the JBLPD peripheral is put into sleep mode setting the SLP bit.

If the bit of the array correspondent to the I.D. byte is clear, then the transfer of this byte as well as any byte for the balance of this frame is inhibited, and the RDRF bit remains cleared.

The bit 0 of the FREG[0] register (FREG[0].0 - marked as F_00 in the previous table) corresponds to the I.D. byte equal to 00h while the bit 7 of the FREG[31] register (FREG[31].7 - marked as F_FF in the previous table) corresponds to the I.D. byte equal to FFh.

Note: The FREG registers are undefined upon reset. Because of this, it is strongly recommended that the contents of these registers has to be defined before JE is set for the first time after reset. Otherwise, unpredictable results may occur.

J1850 Byte Level Protocol Decoder (JBLPD)

J1850 BYTE LEVEL PROTOCOL DECODER (Cont'd)

Register	Address	7								0
STATUS reset value	F0h	ERR 0	TRDY 1	RDRF 0	TLA 0	RDT 0	EODM 0	EOFM 0	IDLE 0	
TXDATA reset value	F1h	TXD7 x	TXD6 x	TXD5 x	TXD4 x	TXD3 x	TXD2 x	TXD1 x	TXD0 x	
RXDATA reset value	F2h	RXD7 x	RXD6 x	RXD5 x	RXD4 x	RXD3 x	RXD2 x	RXD1 x	RXD0 x	
TXOP reset value	F3h	MLC3 0	MLC2 0	MLC1 0	MLC0 0	- 0	OP2 0	OP1 0	OP0 0	
CLKSEL reset value	F4h	4X 0	- 0	FREQ5 0	FREQ4 0	FREQ3 0	FREQ2 0	FREQ1 0	FREQ0 0	
CONTROL reset value	F5h	JE 0	JDIS 1	NFL 0	JDLY4 0	JDLY3 0	JDLY2 0	JDLY1 0	JDLY0 0	
PADDR reset value	F6h	ADR7 x	ADR6 x	ADR5 x	ADR4 x	ADR3 x	ADR2 x	ADR1 x	ADR0 x	
ERROR reset value	F7h	TTO 0	TDUF 0	RDOF 0	TRA 0	RBRK 0	CRCE 0	IFD 0	IBD 0	
IVR reset value	F8h	V7 x	V6 x	V5 x	V4 x	V3 x	EV2 x	EV1 x	- 0	
PRLR reset value	F9h	PRL2 0	PRL1 0	PRL0 0	SLP 1	- 0	- 0	REOBP 0	TEOBP 0	
IMR reset value	FAh	ERR_M 0	TRDY_M 0	RDRF_M 0	TLA_M 0	RXD_M 0	EODM_M 0	EOFM_M 0	TXD_M 0	
OPTIONS reset value	FBh	INPOL 0	NBSYMS 0	DMASUSP 0	LOOPB 0	RSEL3 0	RSEL2 0	RSEL1 0	RSEL0 0	
CREG0 reset value	FCCh	b7 x	b6 x	b5 x	b4 x	b3 x	b2 x	b1 x	b0 x	
CREG1 reset value	FDCh	b7 x	b6 x	b5 x	b4 x	b3 x	b2 x	b1 x	b0 x	
CREG2 reset value	FECh	b7 x	b6 x	b5 x	b4 x	b3 x	b2 x	b1 x	b0 x	
CREG3 reset value	FFCh	b7 x	b6 x	b5 x	b4 x	b3 x	b2 x	b1 x	b0 x	

10.10 CONTROLLER AREA NETWORK (bxCAN)

10.10.1 Introduction

This peripheral **Basic Extended CAN**, named **bxCAN**, interfaces the CAN network. It supports the CAN protocol version 2.0A and B. It has been designed to manage a high number of incoming messages efficiently with a minimum CPU load. It also meets the priority requirements for transmit messages.

For safety-critical applications, the CAN controller provides all hardware functions for supporting the CAN Time Triggered Communication option.

10.10.2 Main Features

- Supports CAN protocol version 2.0 A, B Active
- Bit rates up to 1Mbit/s
- Supports the Time Triggered Communication option

Transmission

- Three transmit mailboxes
- Configurable transmit priority
- Time Stamp on SOF transmission

Reception

- Two receive FIFOs with three stages
- Eight scalable filter banks
- Identifier list feature
- Configurable FIFO overrun
- Time Stamp on SOF reception

Time Triggered Communication Option

- Disable automatic retransmission mode

- 16-bit free running timer
- Configurable timer resolution
- Time Stamp sent in last two data bytes

Management

- Maskable interrupts
- Software-efficient mailbox mapping at a unique address space

10.10.3 General Description

In today's CAN applications, the number of nodes in a network is increasing and often several networks are linked together via gateways. Typically the number of messages in the system (and thus to be handled by each node) has significantly increased. In addition to the application messages, Network Management and Diagnostic messages have been introduced.

– An enhanced filtering mechanism is required to handle each type of message.

Furthermore, application tasks require more CPU time, therefore real-time constraints caused by message reception have to be reduced.

– A receive FIFO scheme allows the CPU to be dedicated to application tasks for a long time period without losing messages.

The standard HLP (Higher Layer Protocol) based on standard CAN drivers requires an efficient interface to the CAN controller.

– All mailboxes and registers are organized in 16-byte pages mapped at the same address and selected via a page select register.

Figure 142. CAN Network Topology

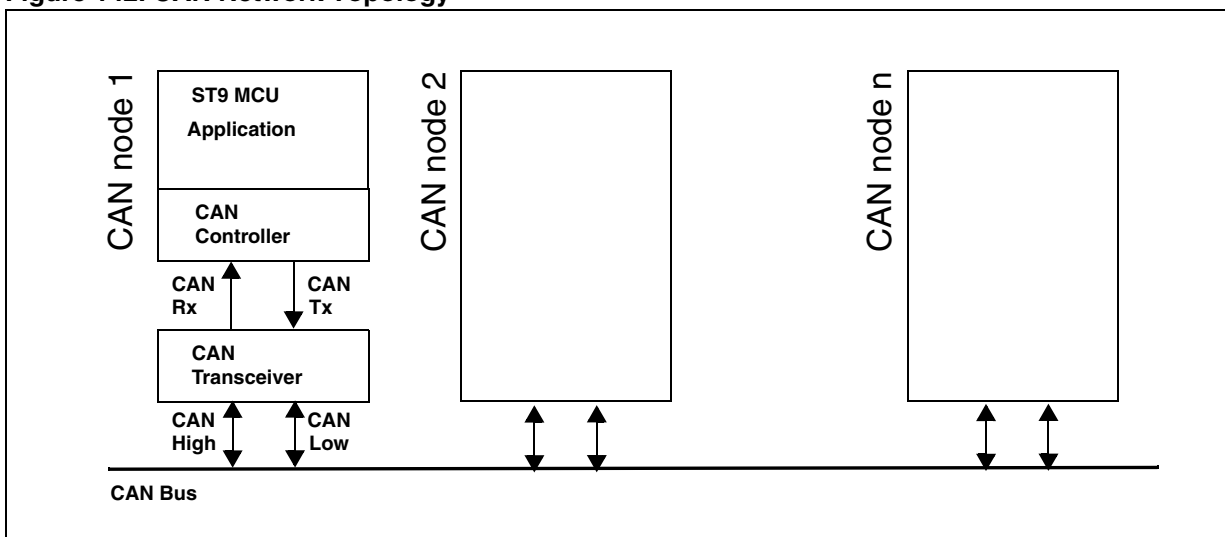

CONTROLLER AREA NETWORK (Cont'd)

CAN 2.0B Active Core

The bxCAN module handles the transmission and the reception of CAN messages fully autonomously. Standard identifiers (11-bit) and extended identifiers (29-bit) are fully supported by hardware.

Control, Status and Configuration Registers

The application uses these registers to:

- Configure CAN parameters, e.g. baud rate
- Request transmissions
- Handle receptions
- Manage interrupts
- Get diagnostic information

Tx Mailboxes

Three transmit mailboxes are provided to the software for setting up messages. The transmission Scheduler decides which mailbox has to be transmitted first.

Acceptance Filters

The bxCAN provides eight scalable/configurable identifier filter banks for selecting the incoming messages the software needs and discarding the others.

Receive FIFO

Two receive FIFOs are used by hardware to store the incoming messages. Three complete messages can be stored in each FIFO. The FIFOs are managed completely by hardware.

Figure 143. CAN Block Diagram

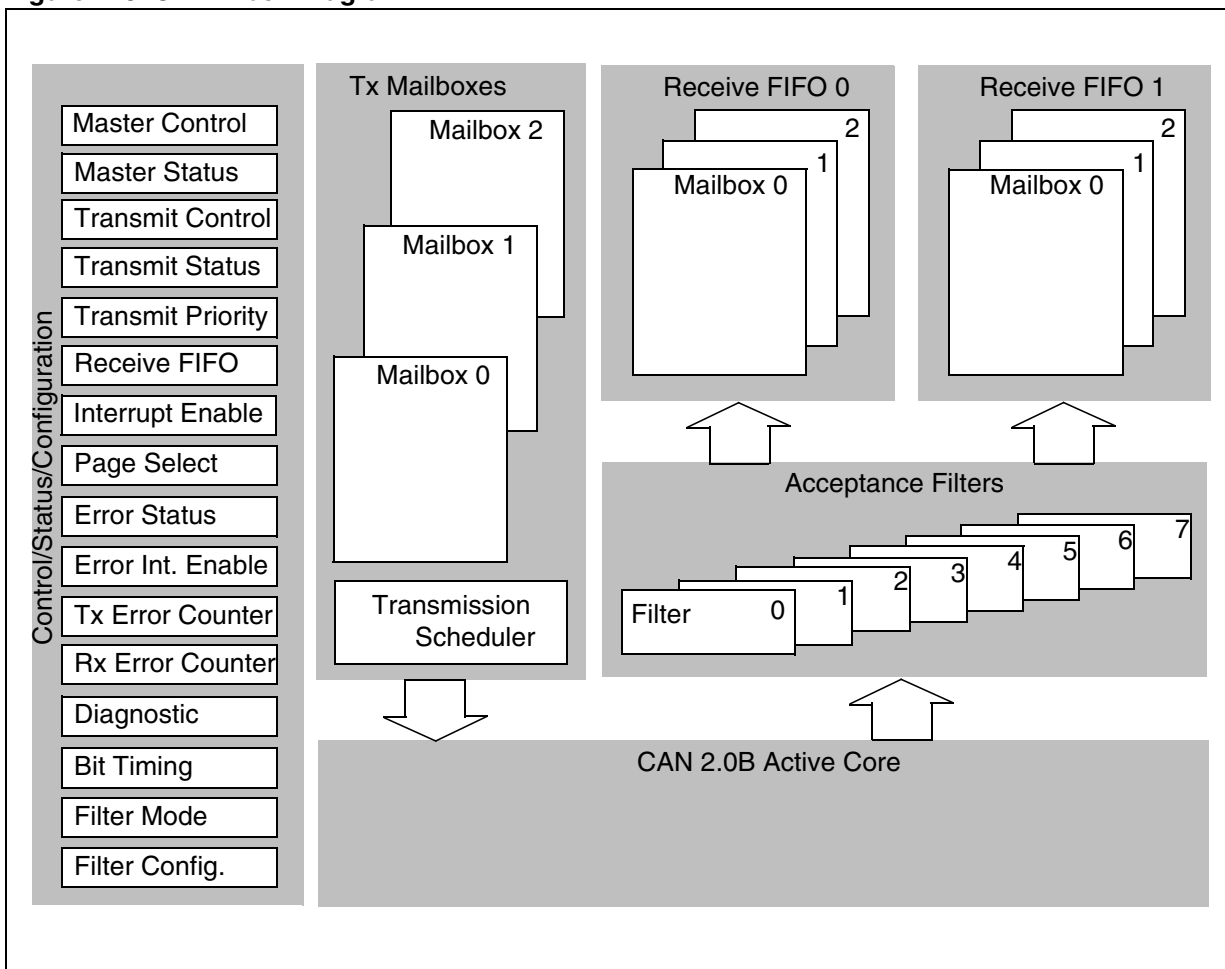

CONTROLLER AREA NETWORK (Cont'd)

Figure 144. bxCAN Operating Modes

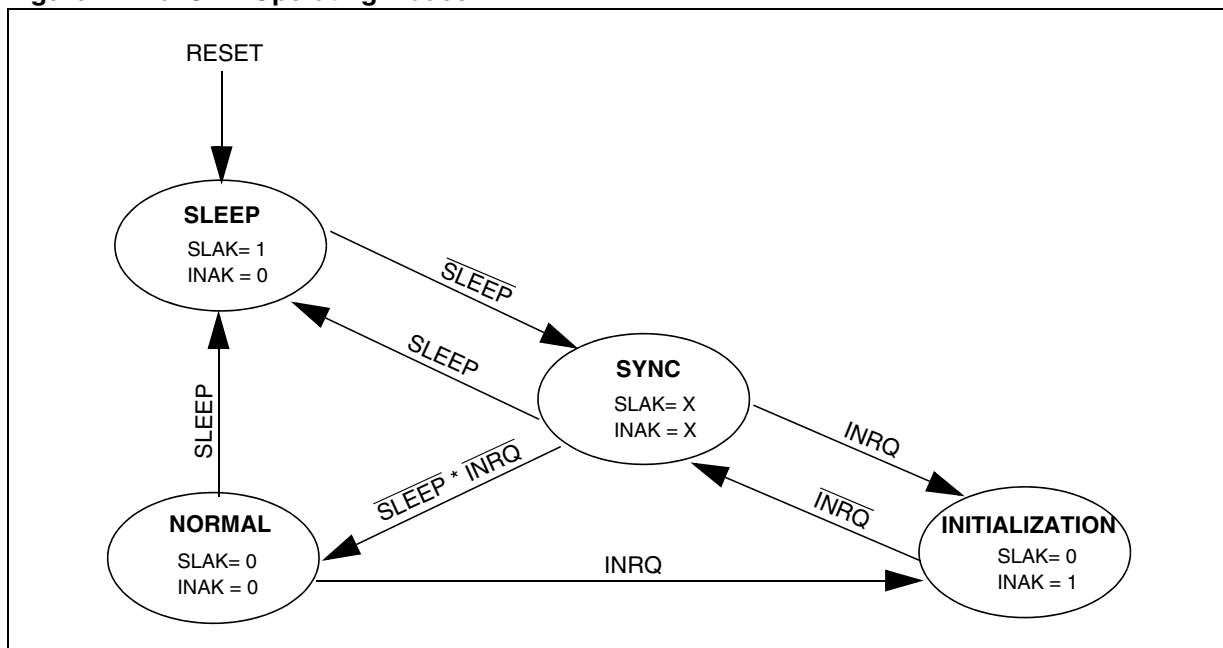

10.10.4 Operating Modes

bxCAN has three main operating modes: **initialization**, **normal** and **sleep**. After a hardware reset, bxCAN is in sleep mode to reduce power consumption and an internal pull-up is active on RX1. The software requests bxCAN to enter **initialization** or **sleep** mode by setting the INRQ or SLEEP bits in the CMCR register. Once the mode has been entered, bxCAN confirms it by setting the INAK or SLAK bits in the CMSR register and the internal pull-up is disabled. When neither INAK nor SLAK are set, bxCAN is in **normal** mode. Before entering **normal** mode bxCAN always has to **synchronize** on the CAN bus. To synchronize, bxCAN waits until the CAN bus is idle, this means 11 consecutive recessive bits have been monitored on CANRX.

10.10.4.1 Initialization Mode

The software initialization can be done while the hardware is in Initialization mode. To enter this mode the software sets the INRQ bit in the CMCR register and waits until the hardware has confirmed the request by setting the INAK bit in the CMSR register.

To leave Initialization mode, the software clears the INQR bit. bxCAN has left Initialization mode once the INAK bit has been cleared by hardware.

While in Initialization Mode, all message transfers to and from the CAN bus are stopped and the sta-

tus of the CAN bus output CANTX is recessive (high).

Entering Initialization Mode does not change any of the configuration registers.

To initialize the CAN Controller, software has to set up the Bit Timing registers and the filters. If a filter bank is not used, it is recommended to leave it non active (leave the corresponding FACT bit cleared).

10.10.4.2 Normal Mode

Once the initialization has been done, the software must request the hardware to enter Normal mode, to synchronize on the CAN bus and start reception and transmission. Entering Normal mode is done by clearing the INRQ bit in the CMCR register and waiting until the hardware has confirmed the request by clearing the INAK bit in the CMSR register. Afterwards, the bxCAN synchronizes with the data transfer on the CAN bus by waiting for the occurrence of a sequence of 11 consecutive recessive bits (≡ Bus Idle) before it can take part in bus activities and start message transfer.

The initialization of the filter values is independent from Initialization Mode but must be done while the filter is not active (corresponding FACTx bit cleared). The filter scale and mode configuration must be configured before entering Normal Mode.

CONTROLLER AREA NETWORK (Cont'd)

10.10.4.3 Low Power Mode (Sleep)

To reduce power consumption, bxCAN has a low power mode called sleep mode. This mode is entered on software request by setting the SLEEP bit in the CMCR register. In this mode, the bxCAN clock is stopped. Consequently, software can still access the bxCAN registers and mailboxes but the bxCAN will not update the status bits.

Example: If software requests entry to **initialization** mode by setting the INRQ bit while bxCAN is in **sleep** mode, it will not be acknowledged by the hardware, INAK stays cleared.

bxCAN can be woken up (exit sleep mode) either by software clearing the SLEEP bit or on detection of CAN bus activity.

On CAN bus activity detection, hardware automatically performs the wake-up sequence by clearing the SLEEP bit if the AWUM bit in the CMCR register is set. If the AWUM bit is cleared, software has to clear the SLEEP bit when a wake-up interrupt occurs, in order to exit from sleep mode.

Note: If the wake-up interrupt is enabled (WKUIE bit set in CIER register) a wake-up interrupt will be generated on detection of CAN bus activity, even if the bxCAN automatically performs the wake-up sequence.

After the SLEEP bit has been cleared, sleep mode is exited once bxCAN has synchronized with the CAN bus, refer to [Figure 144. bxCAN Operating Modes](#). The sleep mode is exited once the SLAK bit has been cleared by hardware.

10.10.4.4 Test Mode

Test mode can be selected by the SILM and LBKM bits in the CDGR register. These bits must be configured while bxCAN is in Initialization mode. Once test mode has been selected, the INRQ bit in the CMCR register must be reset to enter Normal mode.

10.10.4.5 Silent Mode

The bxCAN can be put in Silent mode by setting the SILM bit in the CDGR register.

In Silent mode, the bxCAN is able to receive valid data frames and valid remote frames, but it sends only recessive bits on the CAN bus and it cannot start a transmission. If the bxCAN has to send a dominant bit (ACK bit, overload flag, active error flag), the bit is rerouted internally so that the CAN Core monitors this dominant bit, although the CAN bus may remain in recessive state. Silent mode can be used to analyze the traffic on a CAN bus

without affecting it by the transmission of dominant bits (Acknowledge Bits, Error Frames).

Figure 145. bxCAN in Silent Mode

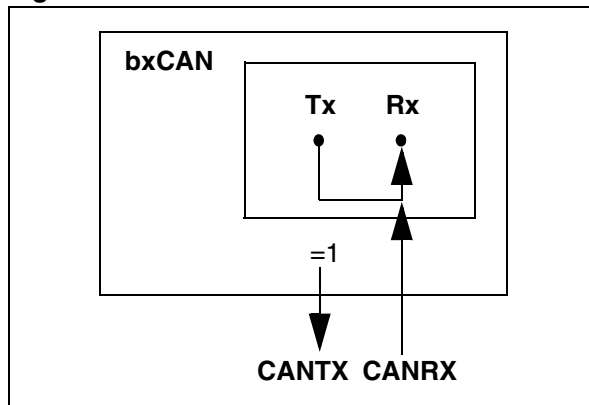

10.10.4.6 Loop Back Mode

The bxCAN can be set in Loop Back Mode by setting the LBKM bit in the CDGR register. In Loop Back Mode, the bxCAN treats its own transmitted messages as received messages and stores them (if they pass acceptance filtering) in a Receive mailbox. bxCAN in Loop Back Mode

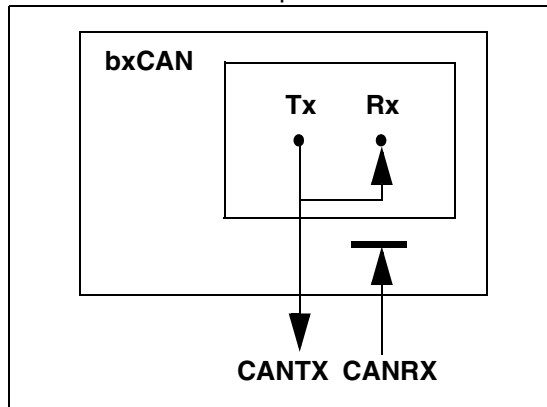

This mode is provided for self-test functions. To be independent of external events, the CAN Core ignores acknowledge errors (no dominant bit sampled in the acknowledge slot of a data / remote frame) in Loop Back Mode. In this mode, the bxCAN performs an internal feedback from its Tx output to its Rx input. The actual value of the CAN-RX input pin is disregarded by the bxCAN. The transmitted messages can be monitored on the CANTX pin.

CONTROLLER AREA NETWORK (Cont'd)

10.10.4.7 Loop Back combined with Silent Mode

It is also possible to combine Loop Back mode and Silent mode by setting the LBKM and SILM bits in the CDGR register. This mode can be used for a "Hot Selftest", meaning the bxCAN can be tested like in Loop Back mode but without affecting a running CAN system connected to the CANTX and CANRX pins. In this mode, the CANRX pin is disconnected from the bxCAN and the CANTX pin is held recessive.

Figure 146. bxCAN in Combined Mode

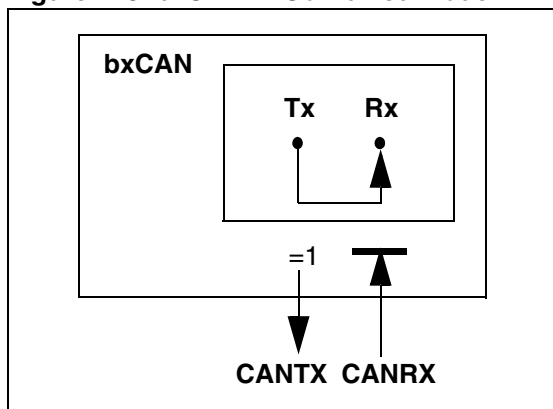

10.10.5 Functional Description

10.10.5.1 Transmission Handling

In order to transmit a message, the application must select one **empty** transmit mailbox, set up the identifier, the data length code (DLC) and the data before requesting the transmission by setting the corresponding TXRQ bit in the MCSR register. Once the mailbox has left **empty** state, the software no longer has write access to the mailbox registers. Immediately after the TXRQ bit has been set, the mailbox enters **pending** state and waits to become the highest priority mailbox, see *Transmit Priority*. As soon as the mailbox has the highest priority it will be **scheduled** for transmission. The transmission of the message of the scheduled mailbox will start (enter **transmit** state) when the CAN bus becomes idle. Once the mailbox has been successfully transmitted, it will become **empty** again. The hardware indicates a successful transmission by setting the RQCP and TXOK bits in the MCSR and CTSR registers.

If the transmission fails, the cause is indicated by the ALST bit in the MCSR register in case of an Ar-

bitration Lost, and/or the TERR bit, in case of transmission error detection.

Transmit Priority

By Identifier:

When more than one transmit mailbox is pending, the transmission order is given by the identifier of the message stored in the mailbox. The message with the lowest identifier value has the highest priority according to the arbitration of the CAN protocol. If the identifier values are equal, the lower mailbox number will be scheduled first.

By Transmit Request Order:

The transmit mailboxes can be configured as a transmit FIFO by setting the TXFP bit in the CMCR register. In this mode the priority order is given by the transmit request order.

This mode is very useful for segmented transmission.

Abort

A transmission request can be aborted by the user setting the ABRQ bit in the MCSR register. In **pending** or **scheduled** state, the mailbox is aborted immediately. An abort request while the mailbox is in **transmit** state can have two results. If the mailbox is transmitted successfully the mailbox becomes **empty** with the TXOK bit set in the MCSR and CTSR registers. If the transmission fails, the mailbox becomes **scheduled**, the transmission is aborted and becomes **empty** with TXOK cleared. In all cases the mailbox will become **empty** again at least at the end of the current transmission.

Non-Automatic Retransmission Mode

This mode has been implemented in order to fulfil the requirement of the Time Triggered Communication option of the CAN standard. To configure the hardware in this mode the NART bit in the CMCR register must be set.

In this mode, each transmission is started only once. If the first attempt fails, due to an arbitration loss or an error, the hardware will not automatically restart the message transmission.

At the end of the first transmission attempt, the hardware considers the request as completed and sets the RQCP bit in the MCSR register. The result of the transmission is indicated in the MCSR register by the TXOK, ALST and TERR bits.

CONTROLLER AREA NETWORK (Cont'd)

Figure 147. Transmit Mailbox States

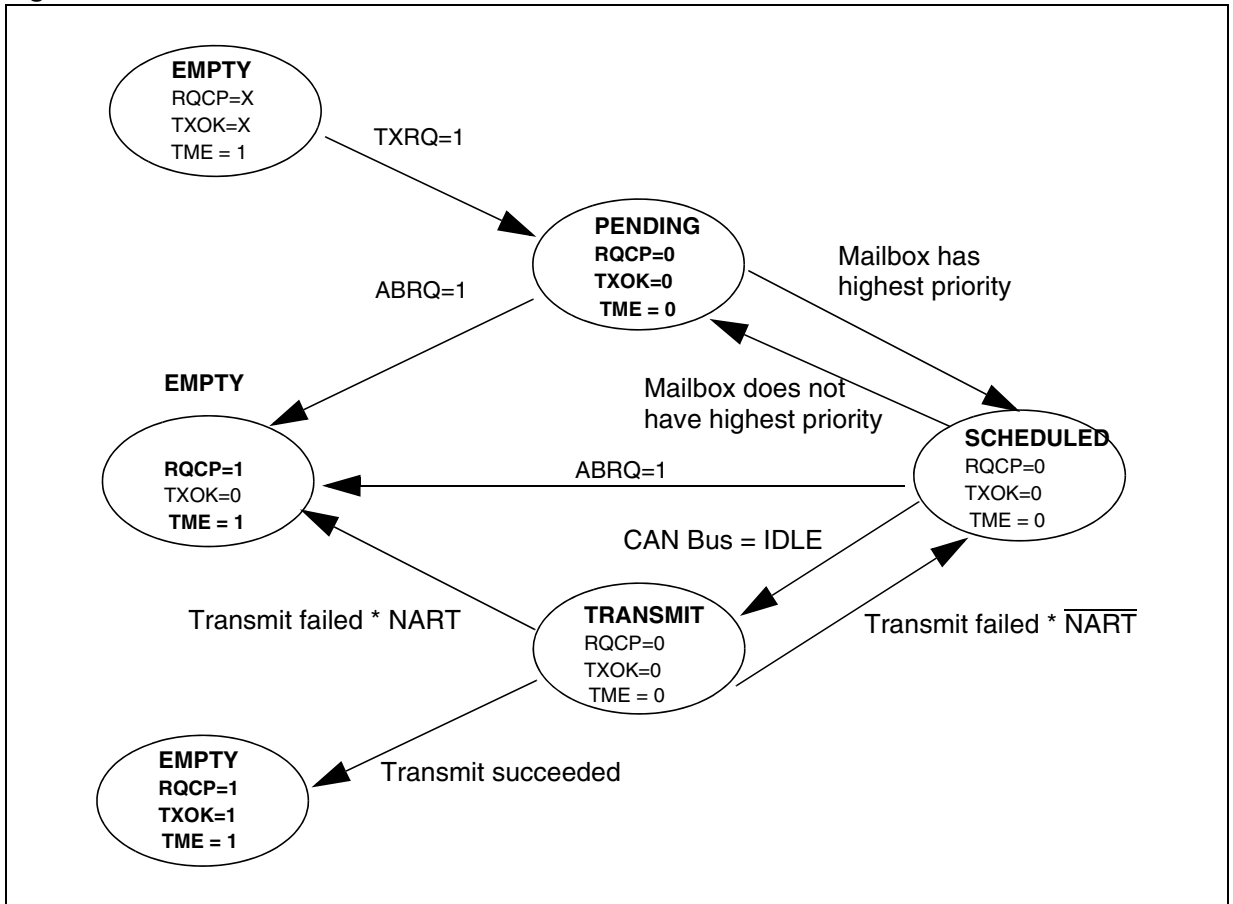

CONTROLLER AREA NETWORK (Cont'd)

10.10.5.2 Time Triggered Communication Mode

In this mode, the internal counter of the CAN hardware is activated and used to generate the Time Stamp value stored in the MTSRH and MTSRL registers. The internal counter is captured on the sample point of the Start Of Frame bit in both reception and transmission.

10.10.5.3 Reception Handling

For the reception of CAN messages, three mailboxes organized as a FIFO are provided. In order to save CPU load, simplify the software and guarantee data consistency, the FIFO is managed

completely by hardware. The application accesses the messages stored in the FIFO through the FIFO output mailbox.

Valid Message

A received message is considered as valid **when** it has been received correctly according to the CAN protocol (no error until the last but one bit of the EOF field) **and** It passed through the identifier filtering successfully, see [Section 10.10.5.4 Identifier Filtering](#).

Figure 148. Receive FIFO states

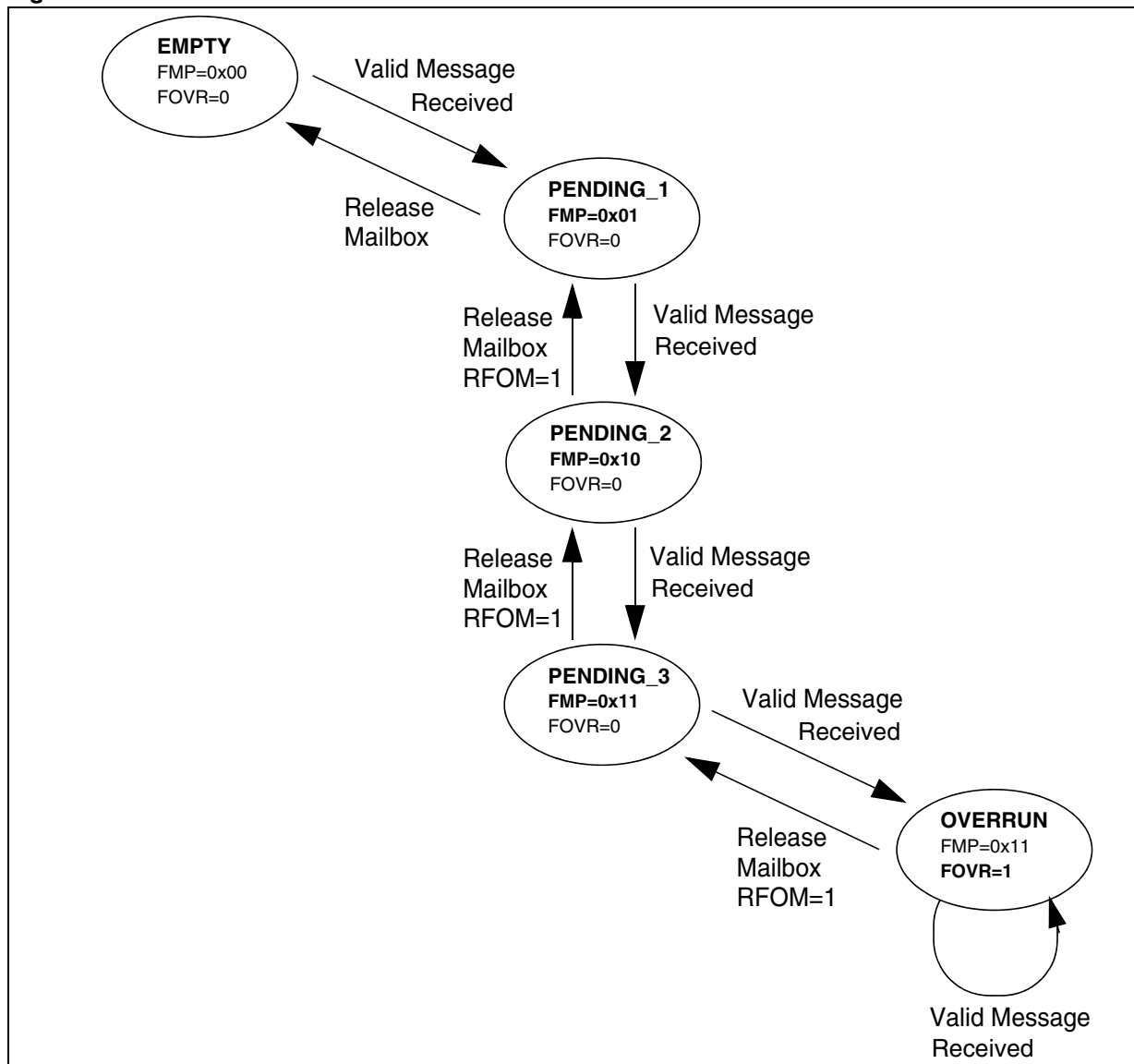

CONTROLLER AREA NETWORK (Cont'd)

FIFO Management

Starting from the **empty** state, the first valid message received is stored in the FIFO which becomes **pending_1**. The hardware signals the event setting the FMP[1:0] bits in the CRFR register to the value 01b. The message is available in the FIFO output mailbox. The software reads out the mailbox content and releases it by setting the RFOM bit in the CRFR register. The FIFO becomes **empty** again. If a new valid message has been received in the meantime, the FIFO stays in **pending_1** state and the new message is available in the output mailbox.

If the application does not release the mailbox, the next valid message will be stored in the FIFO which enters **pending_2** state (FMP[1:0] = 10b). The storage process is repeated for the next valid message putting the FIFO into **pending_3** state (FMP[1:0] = 11b). At this point, the software must release the output mailbox by setting the RFOM bit, so that a mailbox is free to store the next valid message. Otherwise the next valid message received will cause a loss of message.

Refer also to [Section 10.10.5.5 Message Storage](#)

Overrun

Once the FIFO is in **pending_3** state (i.e. the three mailboxes are full) the next valid message reception will lead to an **overrun** and a message will be lost. The hardware signals the overrun condition by setting the FOVR bit in the CRFR register. Which message is lost depends on the configuration of the FIFO:

- If the FIFO lock function is disabled (RFLM bit in the CMCR register cleared) the last message stored in the FIFO will be overwritten by the new incoming message. In this case the latest messages will be always available to the application.
- If the FIFO lock function is enabled (RFLM bit in the CMCR register set) the most recent message will be discarded and the software will have the three oldest messages in the FIFO available.

Reception Related Interrupts

Once a message has been stored in the FIFO, the FMP[1:0] bits are updated and an interrupt request is generated if the FMPIE bit in the CIER register is set.

When the FIFO becomes full (i.e. a third message is stored) the FULL bit in the CRFR register is set and an interrupt is generated if the FFIE bit in the CIER register is set.

On overrun condition, the FOVR bit is set and an interrupt is generated if the FOVIE bit in the CIER register is set.

10.10.5.4 Identifier Filtering

In the CAN protocol the identifier of a message is not associated with the address of a node but related to the content of the message. Consequently a transmitter broadcasts its message to all receivers. On message reception a receiver node decides - depending on the identifier value - whether the software needs the message or not. If the message is needed, it is copied into the RAM. If not, the message must be discarded without intervention by the software.

To fulfil this requirement, the bxCAN Controller provides eight configurable and scalable filterbanks (0-7) to the application, in order to receive only the messages the software needs. This hardware filtering saves CPU resources which would be otherwise needed to perform filtering by software. Each filter bank consists of eight 8-bit registers, CFxR[0:7].

Scalable Width

To optimize and adapt the filters to the application needs, each filter bank can be scaled independently. Depending on the filter scale a filter bank provides:

- One 32-bit filter for the STDID[10:0], IDE, EXTID[17:0] and RTR bits.
- Two 16-bit filters for the STDID[10:0], RTR and IDE bits.
- Four 8-bit filters for the STDID[10:3] bits. The other bits are considered as don't care.
- One 16-bit filter and two 8-bit filters for filtering the same set of bits as the 16 and 8-bit filters described above.

Refer to [Figure 149](#).

Furthermore, the filters can be configured in mask mode or in identifier list mode.

Mask mode

In **mask** mode the identifier registers are associated with mask registers specifying which bits of the identifier are handled as "must match" or as "don't care".

Identifier List mode

In **identifier list** mode, the mask registers are used as identifier registers. Thus instead of defining an identifier and a mask, two identifiers are specified, doubling the number of single identifiers. All bits of the incoming identifier must match the bits specified in the filter registers.

CONTROLLER AREA NETWORK (Cont'd)

Figure 149. Filter Bank Scale Configuration - Register Organisation

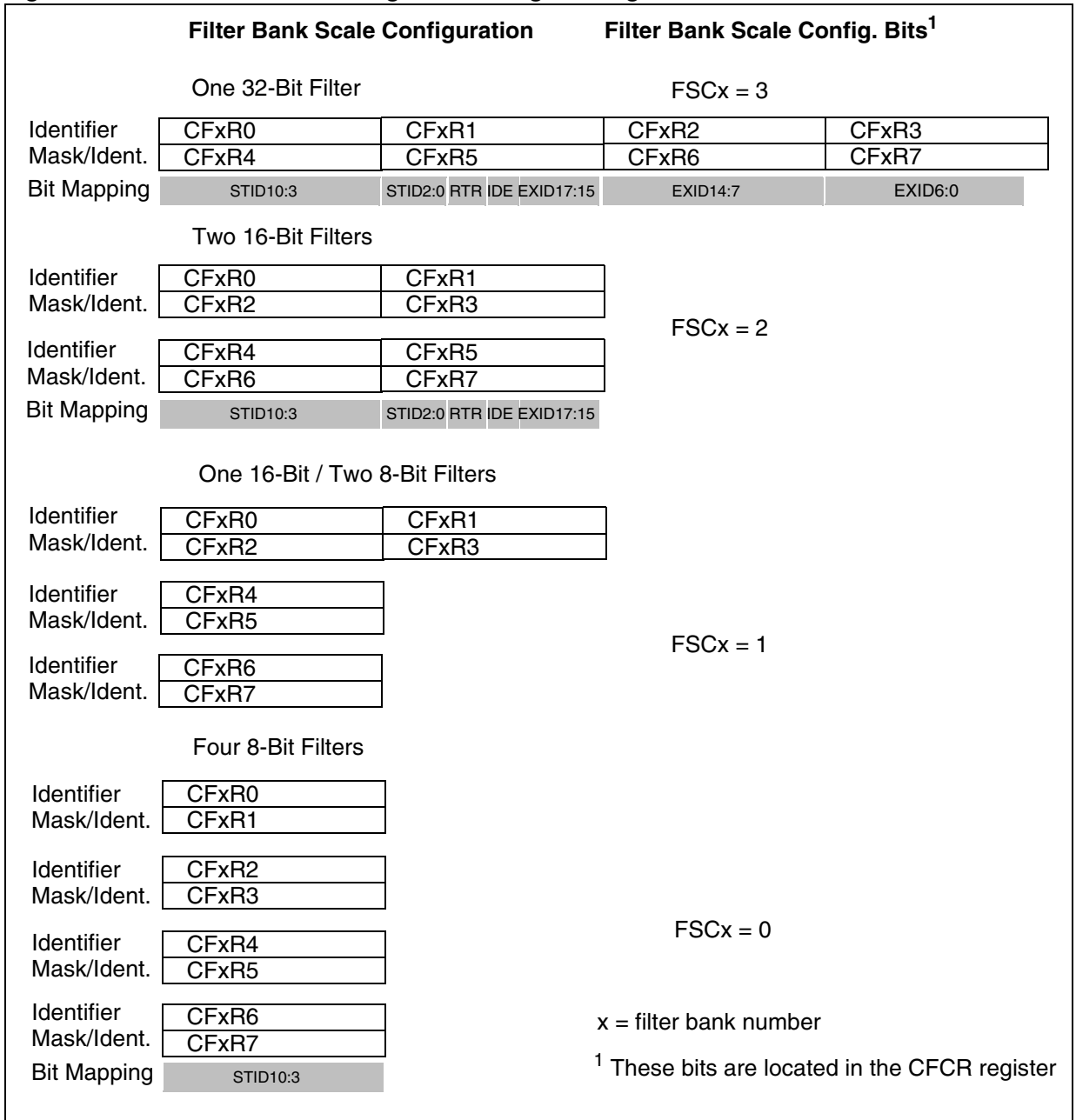

CONTROLLER AREA NETWORK (Cont'd)

Filter Bank Scale and Mode Configuration

The filter banks are configured by means of the corresponding CFCRx register. To configure a filter bank it must be deactivated by clearing the FACT bit in the CFCR register. The filter scale is configured by means of the FSC[1:0] bits in the corresponding CFCR register, refer to [Figure 149](#). The **identifier list** or **identifier mask** mode for the corresponding Mask/Identifier registers is configured by means of the FMCLx and FMCHx bits in the CFMR register. The FMCLx bit defines the mode for the two least significant bytes, and the FMCHx bit the mode for the two most significant bytes of filter bank x. Examples:

- If filter bank 1 is configured as two 16-bit filters, then the FMCL1 bit defines the mode of the CF1R2 and CF1R3 registers and the FMCH1 bit defines the mode of the CF1R6 and CF1R7 registers.
- If filter bank 2 is configured as four 8-bit filters, then the FMCL2 bit defines the mode of the CF2R1 and CF2R3 registers and the FMCH2 bit defines the mode of the CF2R5 and CF2R7 registers.

Note: In 32-bit configuration, the FMCLx and FMCHx bits must have the same value to ensure that the four Mask/Identifier registers are in the same mode.

To filter a group of identifiers, configure the Mask/Identifier registers in mask mode.

To select single identifiers, configure the Mask/Identifier registers in identifier list mode.

Filters not used by the application should be left deactivated.

Filter Match Index

Once a message has been received in the FIFO it is available to the application. Typically application data are copied into RAM locations. To copy the

data to the right location the application has to identify the data by means of the identifier. To avoid this and to ease the access to the RAM locations, the CAN controller provides a Filter Match Index.

This index is stored in the mailbox together with the message according to the filter priority rules. Thus each received message has its associated filter match index.

The Filter Match index can be used in two ways:

- Compare the Filter Match index with a list of expected values.
- Use the Filter Match Index as an index on an array to access the data destination location.

For non-masked filters, the software no longer has to compare the identifier.

If the filter is masked the software reduces the comparison to the masked bits only.

Filter Priority Rules

Depending on the filter combination it may occur that an identifier passes successfully through several filters. In this case the filter match value stored in the receive mailbox is chosen according to the following rules:

- A filter in identifier list mode prevails on a filter in mask mode.
- A filter with full identifier coverage prevails over filters covering part of the identifier, e.g. 16-bit filters prevail over 8-bit filters.
- Filters configured in the same mode and with identical coverage are prioritized by filter number and register number. The lower the number the higher the priority.

CONTROLLER AREA NETWORK (Cont'd)

Figure 150. Filtering Mechanism - example

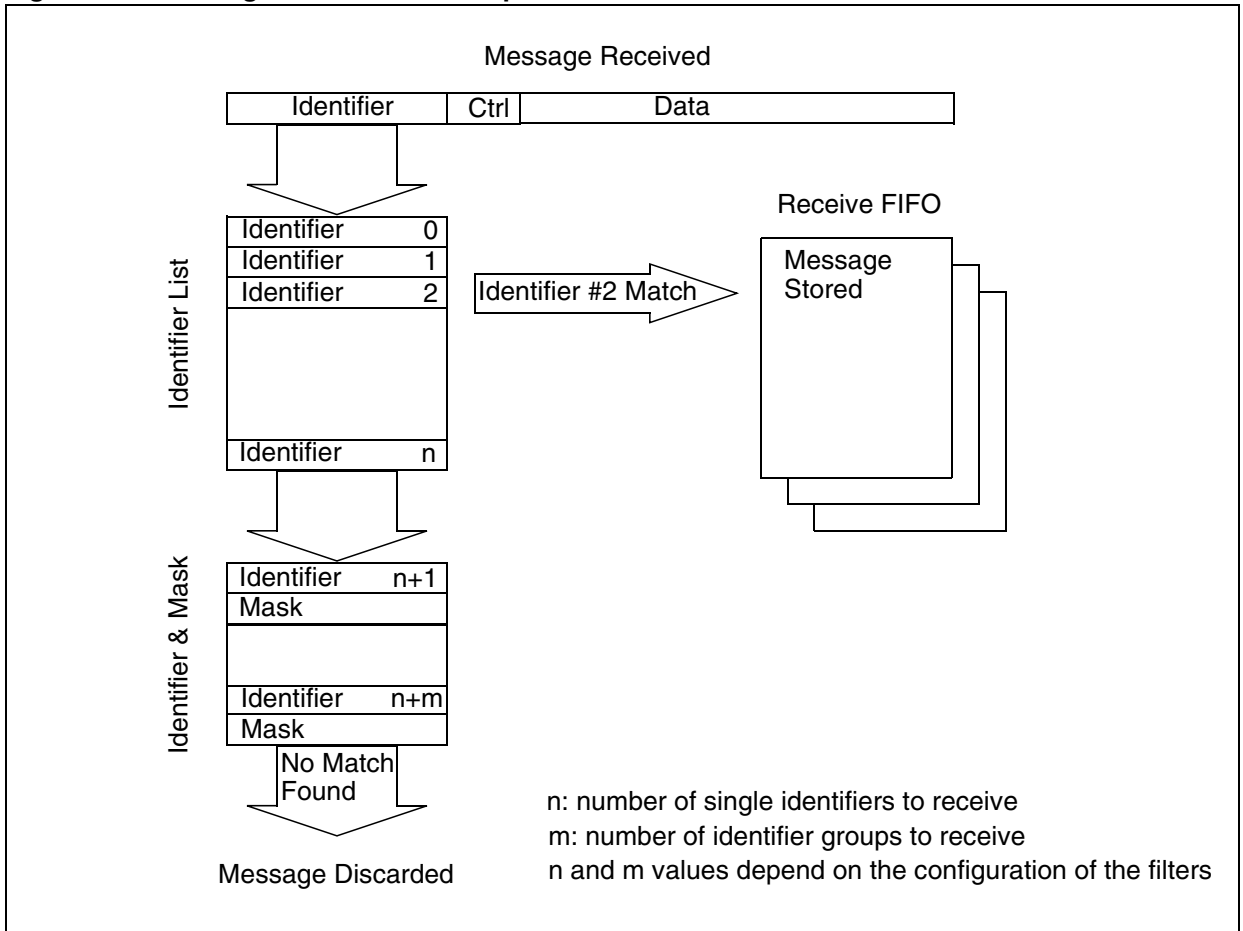

The example above shows the filtering principle of the bxCAN. On reception of a message, the identifier is compared first with the filters configured in identifier list mode. If there is a match, the message is stored in the associated FIFO and the index of the matching filter is stored in the Filter Match Index. As shown in the example, the identifier matches with Identifier #2 thus the message content and MFMI 2 is stored in the FIFO.

If there is no match, the incoming identifier is then compared with the filters configured in mask mode.

If the identifier does not match any of the identifiers configured in the filters, the message is discarded by hardware without disturbing the software.

CONTROLLER AREA NETWORK (Cont'd)

10.10.5.5 Message Storage

The interface between the software and the hardware for the CAN messages is implemented by means of mailboxes. A mailbox contains all information related to a message; identifier, data, control, status and time stamp information.

Transmit Mailbox

The software sets up the message to be transmitted in an empty transmit mailbox. The status of the transmission is indicated by hardware in the MCSR register.

Transmit Mailbox Mapping

Offset to Transmit Mailbox base address (bytes)	Register Name
0	MCSR
1	MDLC
2	MIDR0
3	MIDR1
4	MIDR2
5	MIDR3
6	MDAR0
7	MDAR1
8	MDAR2
9	MDAR3
10	MDAR4
11	MDAR5
12	MDAR6
13	MDAR7
14	MTSR0
15	MTSR1

Receive Mailbox

When a message has been received, it is available to the software in the FIFO output mailbox. Once the software has handled the message (e.g. read it) the software must release the FIFO output mailbox by means of the RFOM bit in the CRFR register to make the next incoming message available. The filter match index is stored in the MFMI register. The 16-bit time stamp value is stored in the MTSR[0:1] registers.

Receive Mailbox Mapping

Offset to Receive Mailbox base address (bytes)	Register Name
0	MFMI
1	MDLC
2	MIDR0
3	MIDR1
4	MIDR2
5	MIDR3
6	MDAR0
7	MDAR1
8	MDAR2
9	MDAR3
10	MDAR4
11	MDAR5
12	MDAR6
13	MDAR7
14	MTSR0
15	MTSR1

CONTROLLER AREA NETWORK (Cont'd)

Figure 151. . CAN Error State Diagram

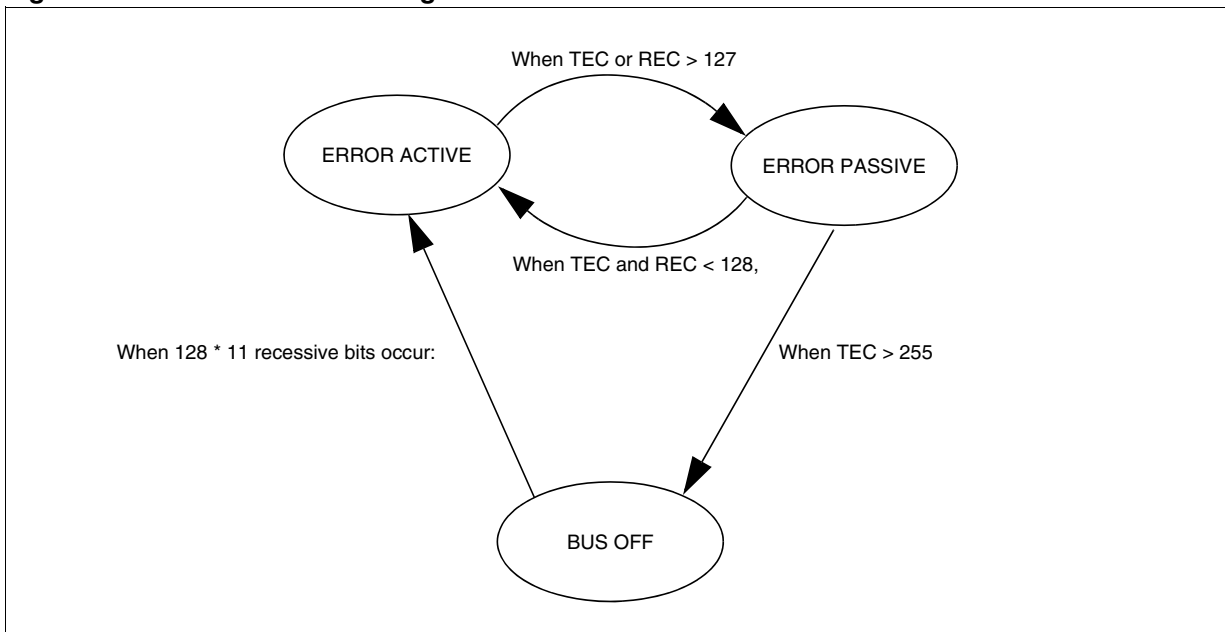

10.10.5.6 Error Management

The error management as described in the CAN protocol is handled entirely by hardware using a Transmit Error Counter (TECR register) and a Receive Error Counter (RECR register), which get incremented or decremented according to the error condition. For detailed information about TEC and REC management, please refer to the CAN standard.

Both of them may be read by software to determine the stability of the network. Furthermore, the CAN hardware provides detailed information on the current error status in CESR register. By means of CEIER register and ERRIE bit in CIER register, the software can configure the interrupt generation on error detection in a very flexible way.

Bus-Off Recovery

The Bus-Off state is reached when TECR is greater than 255, this state is indicated by BOFF bit in CESR register. In Bus-Off state, the bxCAN is no longer able to transmit and receive messages.

Depending on the ABOM bit in the CMCR register bxCAN will recover from Bus-Off (become error active again) either automatically or on software request. But in both cases the bxCAN has to wait at least for the recovery sequence specified in the CAN standard (128 x 11 consecutive recessive bits monitored on CANRX).

If ABOM is set, the bxCAN will start the recovering sequence automatically after it has entered Bus-Off state.

If ABOM is cleared, the software must initiate the recovering sequence by requesting bxCAN to enter and to leave initialization mode.

Note: In initialization mode, bxCAN does not monitor the CANRX signal, therefore it cannot complete the recovery sequence. **To recover, bxCAN must be in normal mode.**

CONTROLLER AREA NETWORK (Cont'd)

10.10.5.7 Bit Timing

The bit timing logic monitors the serial bus-line and performs sampling and adjustment of the sample point by synchronizing on the start-bit edge and re-synchronizing on the following edges.

Its operation may be explained simply by splitting nominal bit time into three segments as follows:

- **Synchronization segment (SYNC_SEG):** a bit change is expected to occur within this time segment. It has a fixed length of one time quantum ($1 \times t_{CAN}$).
- **Bit segment 1 (BS1):** defines the location of the sample point. It includes the PROP_SEG and PHASE_SEG1 of the CAN standard. Its duration is programmable between 1 and 16 time quanta but may be automatically lengthened to compensate for positive phase drifts due to differences in the frequency of the various nodes of the network.
- **Bit segment 2 (BS2):** defines the location of the transmit point. It represents the PHASE_SEG2 of the CAN standard. Its duration is programmable between 1 and 8 time quanta but may also be automatically shortened to compensate for negative phase drifts.

The resynchronization jump width (RJW) defines an upper bound to the amount of lengthening or shortening of the bit segments. It is programmable between 1 and 4 time quanta.

A valid edge is defined as the first transition in a bit time from dominant to recessive bus level provided the controller itself does not send a recessive bit.

If a valid edge is detected in BS1 instead of SYNC_SEG, BS1 is extended by up to RJW so that the sample point is delayed.

Conversely, if a valid edge is detected in BS2 instead of SYNC_SEG, BS2 is shortened by up to RJW so that the transmit point is moved earlier.

As a safeguard against programming errors, the configuration of the Bit Timing Register (BTR) is only possible while the device is in STANDBY mode.

Note: for a detailed description of the CAN bit timing and resynchronization mechanism, please refer to the ISO 11898 standard.

Figure 152. Bit Timing

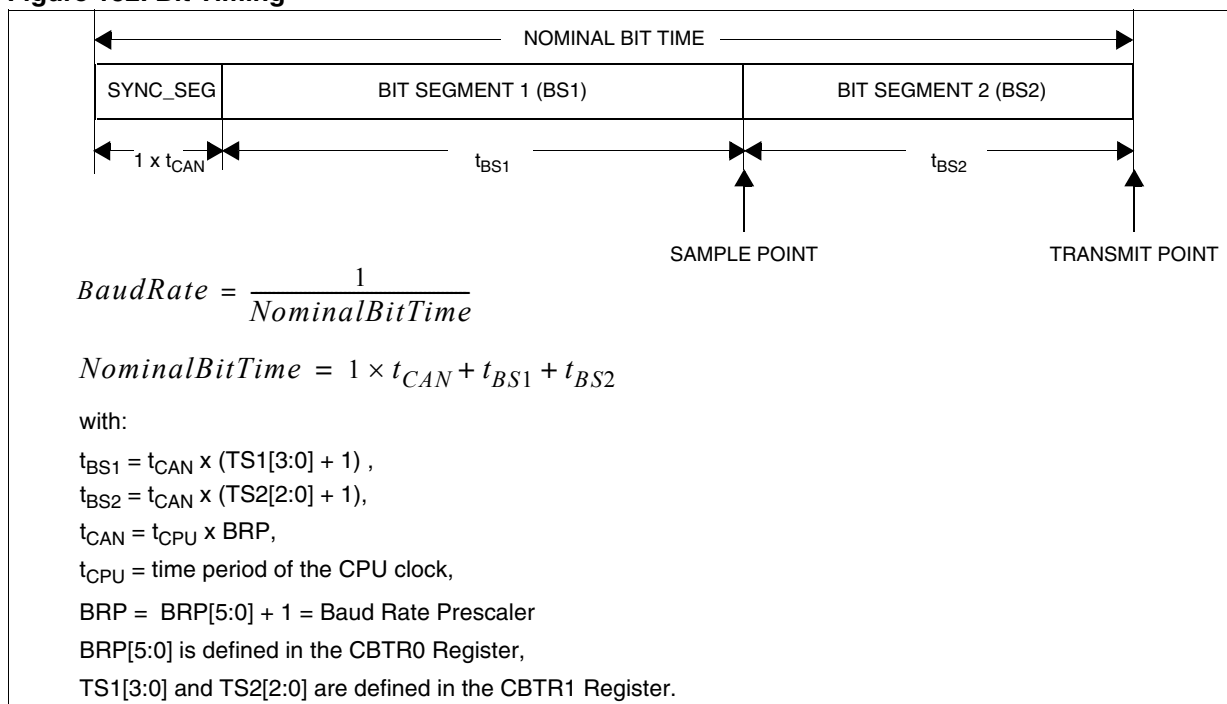

CONTROLLER AREA NETWORK (Cont'd)

Figure 153. CAN Frames

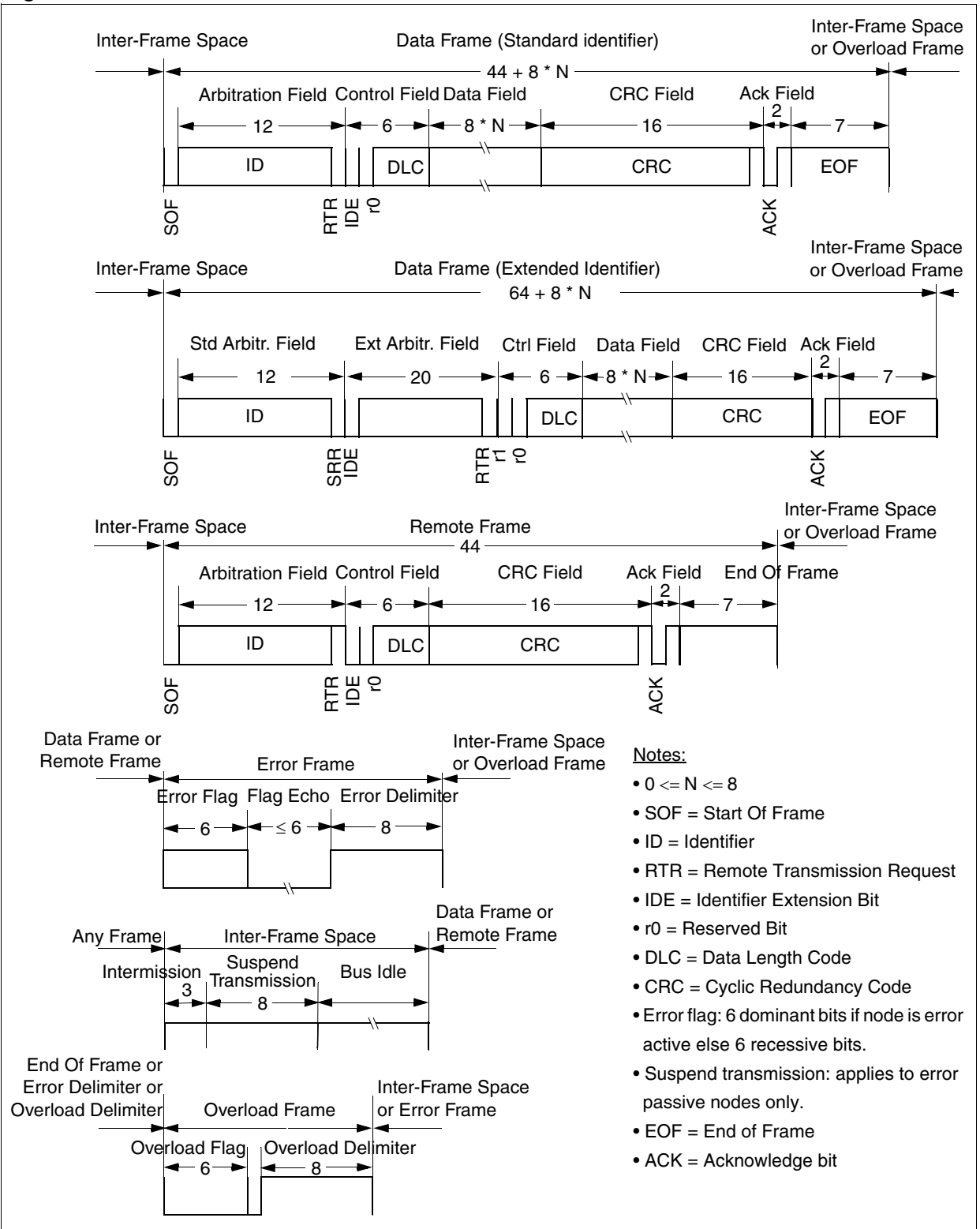

CONTROLLER AREA NETWORK (Cont'd)

10.10.6 Interrupts

Four interrupt vectors are dedicated to bxCAN. Each interrupt source can be independently ena-

bled or disabled by means of the CAN Interrupt Enable Register (CIER) and CAN Error Interrupt Enable register (CEIER).

Figure 154. Event flags and Interrupt Generation

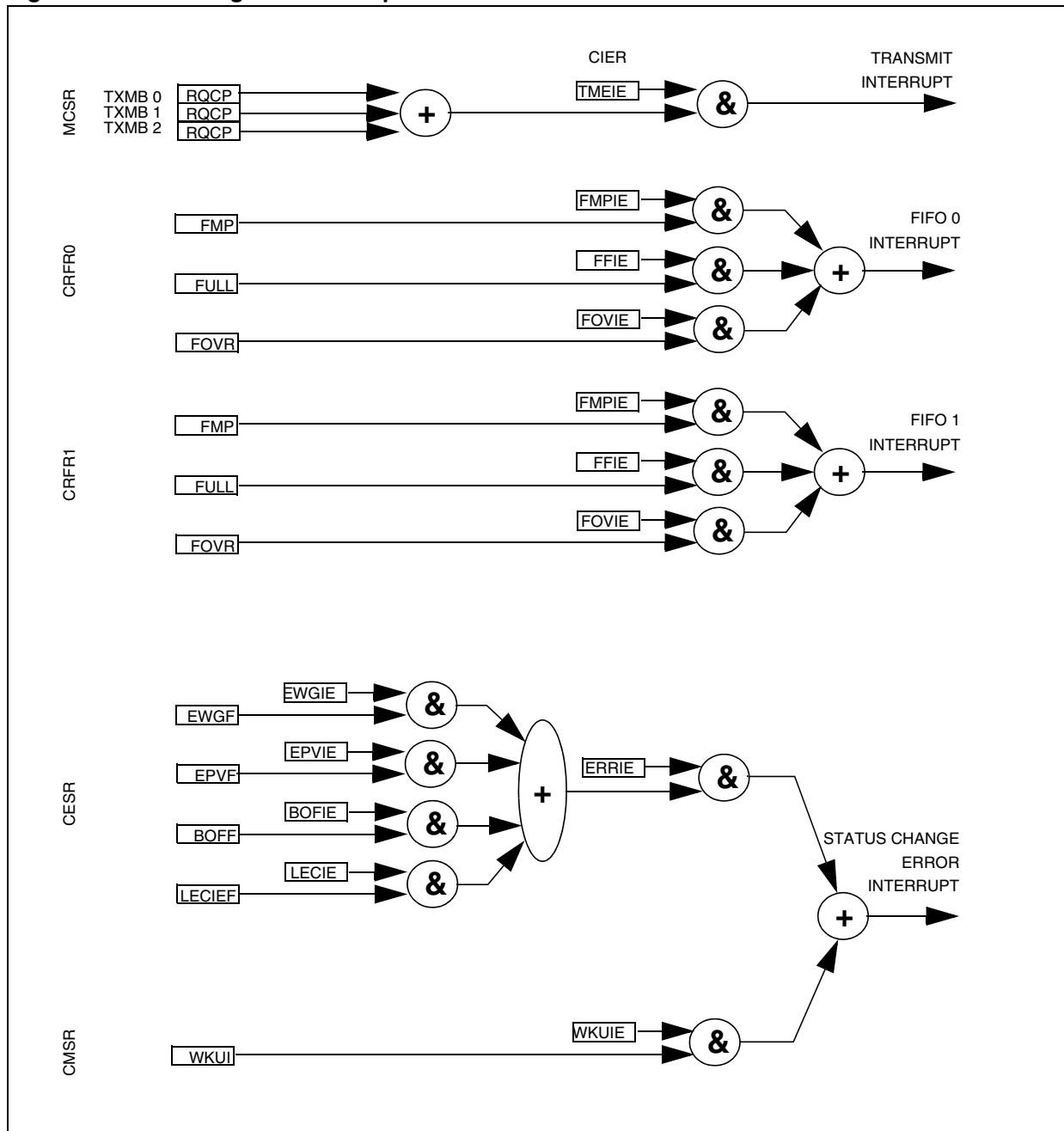

CONTROLLER AREA NETWORK (Cont'd)

- The **transmit interrupt** can be generated by the following events:
 - Transmit mailbox 0 becomes empty, RQCP0 bit in the CTSR register set.
 - Transmit mailbox 1 becomes empty, RQCP1 bit in the CTSR register set.
 - Transmit mailbox 2 becomes empty, RQCP2 bit in the CTSR register set.
- The **FIFO 0 interrupt** can be generated by the following events:
 - Reception of a new message, FMP bits in the CRFR0 register incremented.
 - FIFO0 full condition, FULL bit in the CRFR0 register set.
 - FIFO0 overrun condition, FOVR bit in the CRFR0 register set.
- The **FIFO 1 interrupt** can be generated by the following events:
 - Reception of a new message, FMP bits in the CRFR1 register incremented.
 - FIFO1 full condition, FULL bit in the CRFR1 register set.
 - FIFO1 overrun condition, FOVR bit in the CRFR1 register set.

- The **error and status change interrupt** can be generated by the following events:
 - Error condition, for more details on error conditions please refer to the CAN Error Status register (CESR).
 - Wake-up condition, SOF monitored on the CAN Rx signal.

10.10.7 Register Access Protection

Erroneous access to certain configuration registers can cause the hardware to temporarily disturb the whole CAN network. Therefore the following registers can be modified by software only while the hardware is in initialization mode:

CBTR0, CBTR1, CFCR0, CFCR1, CFMR and CDGR registers.

Although the transmission of incorrect data will not cause problems at the CAN network level, it can severely disturb the application. A transmit mailbox can be only modified by software while it is in empty state, refer to [Figure 147. Transmit Mailbox States](#)

The filters must be deactivated before their value can be modified by software. The modification of the filter configuration (scale or mode) can be done by software only in initialization mode.

CONTROLLER AREA NETWORK (Cont'd)

10.10.8 Register Description

10.10.8.1 Control and Status Registers

CAN MASTER CONTROL REGISTER (CMCR)

Reset Value: 0000 0010 (02h)

7							0
TTCM	ABOM	AWUM	NART	RFLM	TXFP	SLEEP	INRQ

Bit 7 = **TTCM** *Time Triggered Communication Mode*

- Read/Set/Clear

0: Time Triggered Communication mode disabled.

1: Time Triggered Communication mode enabled

Note: For more information on Time Triggered Communication mode, please refer to [Section 10.10.5.2 Time Triggered Communication Mode](#).

Bit 6 = **ABOM** *Automatic Bus-Off Management*

- Read/Set/Clear

This bit controls the behaviour of the CAN hardware on leaving the Bus-Off state.

0: The Bus-Off state is left on software request, once 128 x 11 recessive bits have been monitored and the software has first set and cleared the INRQ bit of the CMCR register.

1: The Bus-Off state is left automatically by hardware once 128 x 11 recessive bits have been monitored.

For detailed information on the Bus-Off state please refer to [Section 10.10.5.6 Error Management](#).

Bit 5 = **AWUM** *Automatic Wake-Up Mode*

- Read/Set/Clear

This bit controls the behaviour of the CAN hardware on message reception during sleep mode.

0: The sleep mode is left on software request by clearing the SLEEP bit of the CMCR register.

1: The sleep mode is left automatically by hardware on CAN message detection. The SLEEP bit of the CMCR register and the SLAK bit of the CMSR register are cleared by hardware.

Bit 4 = **NART** *No Automatic Retransmission*

- Read/Set/Clear

0: The CAN hardware will automatically retransmit the message until it has been successfully transmitted according to the CAN standard.

1: A message will be transmitted only once, independently of the transmission result (successful, error or arbitration lost).

Bit 3 = **RFLM** *Receive FIFO Locked Mode*

- Read/Set/Clear

0: Receive FIFO not locked on overrun. Once a receive FIFO is full the next incoming message will overwrite the previous one.

1: Receive FIFO locked against overrun. Once a receive FIFO is full the next incoming message will be discarded.

Bit 2 = **TXFP** *Transmit FIFO Priority*

- Read/Set/Clear

This bit controls the transmission order when several mailboxes are pending at the same time.

0: Priority driven by the identifier of the message

1: Priority driven by the request order (chronologically)

Bit 1 = **SLEEP** *Sleep Mode Request*

- Read/Set/Clear

This bit is set by software to request the CAN hardware to enter the sleep mode. Sleep mode will be entered as soon as the current CAN activity (transmission or reception of a CAN frame) has been completed.

This bit is cleared by software to exit sleep mode.

This bit is cleared by hardware when the AWUM bit is set and a SOF bit is detected on the CAN Rx signal.

Bit 0 = **INRQ** *Initialization Request*

- Read/Set/Clear

The software clears this bit to switch the hardware into normal mode. Once 11 consecutive recessive bits have been monitored on the Rx signal the CAN hardware is synchronized and ready for transmission and reception. Hardware signals this event by clearing the INAK bit if the CMSR register.

Software sets this bit to request the CAN hardware to enter initialization mode. Once software has set the INRQ bit, the CAN hardware waits until the current CAN activity (transmission or reception) is completed before entering the initialization mode. Hardware signals this event by setting the INAK bit in the CMSR register.

CONTROLLER AREA NETWORK (Cont'd)

CAN MASTER STATUS REGISTER (CMSR)

Reset Value: 0000 0010 (02h)

7							0
0	0	REC	TRAN	WKUI	ERRI	SLAK	INAK

Note: To clear a bit of this register the software must write this bit with a one.

Bit 7:4 = Reserved. Forced to 0 by hardware.

Bit 5 = **REC** *Receive*

- Read

The CAN hardware is currently receiver.

Bit 4 = **TRAN** *Transmit*

- Read

The CAN hardware is currently transmitter.

Bit 3 = **WKUI** *Wake-Up Interrupt*

- Read/Clear

This bit is set by hardware to signal that a SOF bit has been detected while the CAN hardware was in sleep mode. Setting this bit generates a status change interrupt if the WKUIE bit in the CIER register is set.

This bit is cleared by software.

Bit 2 = **ERRI** *Error Interrupt*

- Read/Clear

This bit is set by hardware when a bit of the CESR has been set on error detection and the corresponding interrupt in the CEIER is enabled. Setting this bit generates a status change interrupt if the ERRIE bit in the CIER register is set.

This bit is cleared by software.

Bit 1 = **SLAK** *Sleep Acknowledge*

- Read

This bit is set by hardware and indicates to the software that the CAN hardware is now in sleep mode. This bit acknowledges the sleep mode request from the software (set SLEEP bit in CMCR register).

This bit is cleared by hardware when the CAN hardware has left sleep mode. Sleep mode is left when the SLEEP bit in the CMCR register is

cleared. Please refer to the AWUM bit of the CMCR register description for detailed information for clearing SLEEP bit.

Bit 0 = **INAK** *Initialization Acknowledge*

- Read

This bit is set by hardware and indicates to the software that the CAN hardware is now in initialization mode. This bit acknowledges the initialization request from the software (set INRQ bit in CMCR register).

This bit is cleared by hardware when the CAN hardware has left the initialization mode and is now synchronized on the CAN bus. To be synchronized the hardware has to monitor a sequence of 11 consecutive recessive bits on the CAN RX signal.

CAN TRANSMIT STATUS REGISTER (CTSR)

Read / Write

Reset Value: 0000 0000 (00h)

7							0
0	TXOK2	TXOK1	TXOK0	0	RQCP2	RQCP1	RQCP0

Note: To clear a bit of this register the software must write this bit with a one.

Bit 7 = Reserved. Forced to 0 by hardware.

Bit 6 = **TXOK2** *Transmission OK for mailbox 2*

- Read

This bit is set by hardware when the transmission request on mailbox 2 has been completed successfully. Please refer to [Figure 147](#).

This bit is cleared by hardware when mailbox 2 is requested for transmission or when the software clears the RQCP2 bit.

Bit 5 = **TXOK1** *Transmission OK for mailbox 1*

- Read

This bit is set by hardware when the transmission request on mailbox 1 has been completed successfully. Please refer to [Figure 147](#).

This bit is cleared by hardware when mailbox 1 is requested for transmission or when the software clears the RQCP1 bit.

CONTROLLER AREA NETWORK (Cont'd)

Bit 4 = **TXOK0** *Transmission OK for mailbox 0*
- Read

This bit is set by hardware when the transmission request on mailbox 0 has been completed successfully. Please refer to [Figure 147](#).

This bit is cleared by hardware when mailbox 0 is requested for transmission or when the software clears the RQCP0 bit.

Bit 3 = Reserved. Forced to 0 by hardware.

Bit 2 = **RQCP2** *Request Completed for Mailbox 2*
- Read/Clear

This bit is set by hardware to signal that the last request for mailbox 2 has been completed. The request could be a transmit or an abort request.

This bit is cleared by software.

Bit 1 = **RQCP1** *Request Completed for Mailbox 1*
- Read/Clear

This bit is set by hardware to signal that the last request for mailbox 1 has been completed. The request could be a transmit or an abort request.

This bit is cleared by software.

Bit 0 = **RQCP0** *Request Completed for Mailbox 0*
- Read/Clear

This bit is set by hardware to signal that the last request for mailbox 0 has been completed. The request could be a transmit or an abort request.

This bit is cleared by software.

CAN TRANSMIT PRIORITY REGISTER (CTPR)

All bits of this register are read only.

Reset Value: 0000 0000 (00h)

7								0
LOW2	LOW1	LOW0	TME2	TME1	TME0	CODE1	CODE0	

Bit 7 = **LOW2** *Lowest Priority Flag for Mailbox 2*
- Read

This bit is set by hardware when more than one mailbox are pending for transmission and mailbox 2 has the lowest priority.

Bit 6 = **LOW1** *Lowest Priority Flag for Mailbox 1*
- Read

This bit is set by hardware when more than one mailbox are pending for transmission and mailbox 1 has the lowest priority.

Bit 5 = **LOW0** *Lowest Priority Flag for Mailbox 0*
- Read

This bit is set by hardware when more than one mailbox are pending for transmission and mailbox 0 has the lowest priority.

Note: These bits are set to zero when only one mailbox is pending.

Bit 4 = **TME2** *Transmit Mailbox 2 Empty*
- Read

This bit is set by hardware when no transmit request is pending for mailbox 2.

Bit 3 = **TME1** *Transmit Mailbox 1 Empty*
- Read

This bit is set by hardware when no transmit request is pending for mailbox 1.

Bit 2 = **TME0** *Transmit Mailbox 0 Empty*
- Read

This bit is set by hardware when no transmit request is pending for mailbox 0.

Bit 1:0 = **CODE[1:0]** *Mailbox Code*
- Read

In case at least one transmit mailbox is free, the code value is equal to the number of the next transmit mailbox free.

In case all transmit mailboxes are pending, the code value is equal to the number of the transmit mailbox with the lowest priority.

CONTROLLER AREA NETWORK (Cont'd)

CAN RECEIVE FIFO REGISTERS (CRFRx)

Read / Write

Reset Value: 0000 0000 (00h)

7							0
0	0	RFOM	FOVR	FULL	0	FMP1	FMP0

Note: To clear a bit in this register, software must write a "1" to the bit.

Bit 7:6 = Reserved. Forced to 0 by hardware.

Bit 5 = **RFOM** *Release FIFO Output Mailbox*
- Read/Set

Set by software to release the output mailbox of the FIFO. The output mailbox can only be released when at least one message is pending in the FIFO. Setting this bit when the FIFO is empty has no effect. If at least two messages are pending in the FIFO, the software has to release the output mailbox to access the next message.

Cleared by hardware when the output mailbox has been released.

Bit 4 = **FOVR** *FIFO Overrun*

- Read/Clear

This bit is set by hardware when a new message has been received and passed the filter while the FIFO was full.

This bit is cleared by software.

Bit 3 = **FULL** *FIFO Full*

- Read/Clear

Set by hardware when three messages are stored in the FIFO.

This bit is cleared by software.

Bit 2 = Reserved. Forced to 0 by hardware.

Bit 1:0 = **FMP[1:0]** *FIFO Message Pending*

- Read

These bits indicate how many messages are pending in the receive FIFO.

FMP is increased each time the hardware stores a new message in to the FIFO. FMP is decreased each time the software releases the output mailbox by setting the RFOM bit.

CAN INTERRUPT ENABLE REGISTER (CIER)

All bits of this register are set and cleared by software.

Read / Write

Reset Value: 0000 0000 (00h)

7							0
WKUIE	FOVIE1	FFIE1	FMPIE1	FOVIE0	FFIE0	FMPIE0	TMEIE

Bit 7 = **WKUIE** *Wake-Up Interrupt Enable*

0: No interrupt when WKUI is set.

1: Interrupt generated when WKUI bit is set.

Bit 6 = **FOVIE1** *FIFO Overrun Interrupt Enable*

0: No interrupt when FOVR is set.

1: Interrupt generation when FOVR is set.

Bit 5 = **FFIE1** *FIFO Full Interrupt Enable*

0: No interrupt when FULL bit is set.

1: Interrupt generated when FULL bit is set.

Bit 4 = **FMPIE1** *FIFO Message Pending Interrupt Enable*

0: No interrupt on FMP[1:0] bits transition from 00b to 01b.

1: Interrupt generated on FMP[1:0] bits transition from 00b to 01b.

Bit 3 = **FOVIE0** *FIFO Overrun Interrupt Enable*

0: No interrupt when FOVR bit is set.

1: Interrupt generated when FOVR bit is set.

Bit 2 = **FFIE0** *FIFO Full Interrupt Enable*

0: No interrupt when FULL bit is set.

1: Interrupt generated when FULL bit is set.

Bit 1 = **FMPIE0** *FIFO Message Pending Interrupt Enable*

0: No interrupt on FMP[1:0] bits transition from 00b to 01b.

1: Interrupt generated on FMP[1:0] bits transition from 00b to 01b.

Bit 0 = **TMEIE** *Transmit Mailbox Empty Interrupt Enable*

0: No interrupt when RQCPx bit is set.

1: Interrupt generated when RQCPx bit is set.

Note: refer to Standard Interrupts Section.

CONTROLLER AREA NETWORK (Cont'd)

CAN ERROR STATUS REGISTER (CESR)

Read / Write

Reset Value: 0000 0000 (00h)

7							0
0	LEC2	LEC1	LEC0	0	BOFF	EPVF	EWGF

Bit 7 = Reserved. Forced to 0 by hardware.

Bit 6:4 = **LEC[2:0] Last Error Code**

- Read/Set/Clear

This field holds a code which indicates the type of the last error detected on the CAN bus. If a message has been transferred (reception or transmission) without error, this field will be cleared to '0'. The code 7 is unused and may be written by the CPU to check for update

Table 63. LEC Error Types

Code	Error Type
0	No Error
1	Stuff Error
2	Form Error
3	Acknowledgment Error
4	Bit recessive Error
5	Bit dominant Error
6	CRC Error
7	Set by software

Bit 3 = Reserved. Forced to 0 by hardware.

Bit 2 = **BOFF Bus-Off Flag**

- Read

This bit is set by hardware when it enters the bus-off state. The bus-off state is entered on TECR overrun, TEC greater than 255, refer to [Section 10.10.5.6 on page 338](#).

Bit 1 = **EPVF Error Passive Flag**

- Read

This bit is set by hardware when the Error Passive limit has been reached (Receive Error Counter or Transmit Error Counter greater than 127).

Bit 1 = **EWGF Error Warning Flag**

- Read

This bit is set by hardware when the warning limit has been reached. Receive Error Counter or Transmit Error Counter greater than 96.

CAN ERROR INTERRUPT ENABLE REGISTER (CEIER)

All bits of this register are set and clear by software.

Read/Write

Reset Value: 0000 0000 (00h)

7							0
ERRIE	0	0	LECIE	0	BOFIE	EPVIE	EWGIE

Bit 7 = **ERRIE Error Interrupt Enable**

0: No interrupt will be generated when an error condition is pending in the CESR.

1: An interrupt will be generated when an error condition is pending in the CESR.

Bit 6:5 = Reserved. Forced to 0 by hardware.

Bit 4 = **LECIE Last Error Code Interrupt Enable**

0: ERRI bit will not be set when the error code in LEC[2:0] is set by hardware on error detection.

1: ERRI bit will be set when the error code in LEC[2:0] is set by hardware on error detection.

Bit 3 = Reserved. Forced to 0 by hardware.

Bit 2 = **BOFIE Bus-Off Interrupt Enable**

0: ERRI bit will not be set when BOFF is set.

1: ERRI bit will be set when BOFF is set.

Bit 1 = **EPVIE Error Passive Interrupt Enable**

0: ERRI bit will not be set when EPVF is set.

1: ERRI bit will be set when EPVF is set.

Bit 0 = **EWGIE Error Warning Interrupt Enable**

0: ERRI bit will not be set when EWGF is set.

1: ERRI bit will be set when EWGF is set.

Note: refer to Standard Interrupts Section.

CONTROLLER AREA NETWORK (Cont'd)

TRANSMIT ERROR COUNTER REG. (TECR)

Read Only

Reset Value: 00h

7								0
TEC7	TEC6	TEC5	TEC4	TEC3	TEC2	TEC1	TEC0	

TEC[7:0] is the least significant byte of the 9-bit Transmit Error Counter implementing part of the fault confinement mechanism of the CAN protocol.

RECEIVE ERROR COUNTER REG. (RECR)

Page: 00h — Read Only

Reset Value: 00h

7								0
REC7	REC6	REC5	REC4	REC3	REC2	REC1	REC0	

REC[7:0] is the Receive Error Counter implementing part of the fault confinement mechanism of the CAN protocol. In case of an error during reception, this counter is incremented by 1 or by 8 depending on the error condition as defined by the CAN standard. After every successful reception the counter is decremented by 1 or reset to 120 if its value was higher than 128. When the counter value exceeds 127, the CAN controller enters the error passive state.

CAN DIAGNOSIS REGISTER (CDGR)

All bits of this register are set and clear by software.

Read / Write

Reset Value: 0000 0000 (00h)

7								0
0	0	0	0	RX	SAMP	SILM	LBKM	

Bit 3 = **RX CAN Rx Signal**

- Read

Monitors the actual value of the **CAN_RX** Pin.

Bit 2 = **SAMP Last Sample Point**

- Read

The value of the last sample point.

Bit 1 = **SILM Silent Mode**

- Read/Set/Clear

0: Normal operation

1: Silent Mode

Bit 0 = **LBKM Loop Back Mode**

- Read/Set/Clear

0: Loop Back Mode disabled

1: Loop Back Mode enabled

CONTROLLER AREA NETWORK (Cont'd)

CAN BIT TIMING REGISTER 0 (CBTR0)

This register can only be accessed by the software when the CAN hardware is in configuration mode.
Read / Write

Reset Value: 0000 0000 (00h)

7								0
SJW1	SJW0	BRP5	BRP4	BRP3	BRP2	BRP1	BRP0	

Bit 7:6 **SJW[1:0]** *Resynchronization Jump Width*
These bits define the maximum number of time quanta the CAN hardware is allowed to lengthen or shorten a bit to perform the resynchronization.

Bit 5:0 **BRP[5:0]** *Baud Rate Prescaler*
These bits define the length of a time quantum.
 $t_q = (BRP+1)/f_{sys}$

For more information on bit timing, please refer to [Section 10.10.5.7 Bit Timing](#).

CAN BIT TIMING REGISTER 1 (CBTR1)

Read / Write

Reset Value: 0001 0011 (23h)

7								0
0	TS22	TS21	TS20	TS13	TS12	TS11	TS10	

Bit 7 = Reserved. Forced to 0 by hardware.

Bit 6:4 **TS2[2:0]** *Time Segment 2*
These bits define the number of time quanta in Time Segment 2.
 $t_{BS2} = t_{CAN} \times (TS2[2:0] + 1)$,

Bit 3:0 **TS1[3:0]** *Time Segment 1*
These bits define the number of time quanta in Time Segment 1
 $t_{BS1} = t_{CAN} \times (TS1[3:0] + 1)$

.For more information on bit timing, please refer to [Section 10.10.5.7 Bit Timing](#).

CAN FILTER PAGE SELECT REGISTER (CFPSR)

All bits of this register are set and cleared by software.

Read / Write

Reset Value: 0000 0000 (00h)

7									0
0	0	0	0	0	0	FPS2	FPS1	FPS0	

Bit 7:3 = Reserved. Forced to 0 by hardware.

Bit 2:0 = **FPS[2:0]** *Filter Page Select*
- Read/Write

This register contains the filter page number available in page 54.

Table 64. Filter Page Selection

FPS[2:0]	Filter Page Selected in Page 54
0	Acceptance Filter 0:1
1	Acceptance Filter 2:3
2	Acceptance Filter 4:5
3	Acceptance Filter 6:7
4	Filter Configuration
5	Filter Configuration
6	Filter Configuration
7	Filter Configuration

CONTROLLER AREA NETWORK (Cont'd)

10.10.8.2 Mailbox Registers

This chapter describes the registers of the transmit and receive mailboxes. Refer to [Section 10.10.5.5 Message Storage](#) for detailed register mapping.

Transmit and receive mailboxes have the same registers except:

- MCSR register in a transmit mailbox is replaced by MFMI register in a receive mailbox.
- A receive mailbox is always write protected.
- A transmit mailbox is write enable only while empty, corresponding TME bit in the CTPR register set.

MAILBOX CONTROL STATUS REGISTER (MCSR)

Read / Write

Reset Value: 0000 0000 (00h)

7							0
0	0	TERR	ALST	TXOK	RQCP	ABRQ	TXRQ

Bit 7:6 = Reserved. Forced to 0 by hardware.

Bit 5 = **TERR** *Transmission Error*

- Read/Clear

This bit is updated by hardware after each transmission attempt.

- 0: The previous transmission was successful
- 1: The previous transmission failed due to an error

Bit 4 = **ALST** *Arbitration Lost*

- Read/Clear

This bit is updated by hardware after each transmission attempt.

- 0: The previous transmission was successful
- 1: The previous transmission failed due to an arbitration lost

Bit 3 = **TXOK** *Transmission OK*

- Read/Clear

The hardware updates this bit after each transmission attempt.

0: The previous transmission failed

1: The previous transmission was successful

Note: This bit has the same value as the corresponding TXOKx bit in the CTSR register.

Bit 2 = **RQCP** *Request Completed*

- Read/Clear

Set by hardware when the last request (transmit or abort) has been performed.

Cleared by software writing a “1” or by hardware on transmission request.

Note: This bit has the same value as the corresponding RQCPx bit of the CTSR register.

Clearing this bit clears all the status bits (TXOK, ALST and TERR) in the MCSR register and the RQCP and TXOK bits in the CTSR register.

Bit 1 = **ABRQ** *Abort Request for Mailbox*

- Read/Set

Set by software to abort the transmission request for the corresponding mailbox.

Cleared by hardware when the mailbox becomes empty.

Setting this bit has no effect when the mailbox is not pending for transmission.

Bit 0 = **TXRQ** *Transmit Mailbox Request*

- Read/Set

Set by software to request the transmission for the corresponding mailbox.

Cleared by hardware when the mailbox becomes empty.

Note: This register is implemented only in transmit mailboxes. In receive mailboxes, the MFMI register is mapped at this location.

CONTROLLER AREA NETWORK (Cont'd)

MAILBOX FILTER MATCH INDEX (MFMI)

This register is read only.

Reset Value: 0000 0000 (00h)

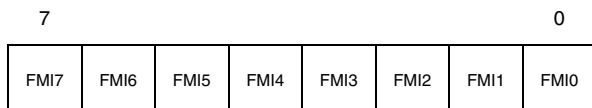

Bit 7:0 = **FMI[7:0]** *Filter Match Index*

This register contains the index of the filter the message stored in the mailbox passed through. For more details on identifier filtering please refer to [Section 10.10.5.4 - Filter Match Index](#) paragraph.

Note: This register is implemented only in receive mailboxes. In transmit mailboxes, the MCSR register is mapped at this location.

MAILBOX IDENTIFIER REGISTERS (MIDR[3:0])

Read / Write

Reset Value: xxxx xxxx (xxh)

MIDR0

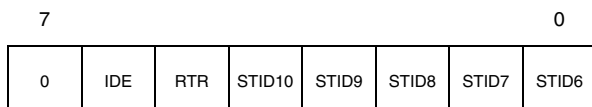

Bit 7 = Reserved. Forced to 0 by hardware.

Bit 6 = **IDE** *Extended Identifier*

This bit defines the identifier type of message in the mailbox.

0: Standard identifier.
1: Extended identifier.

Bit 5 = **RTR** *Remote Transmission Request*

0: Data frame
1: Remote frame

Bit 4:0 = **STID[10:6]** *Standard Identifier*

5 most significant bits of the standard part of the identifier.

MIDR1

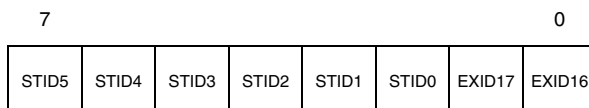

Bit 7:2 = **STID[5:0]** *Standard Identifier*

6 least significant bits of the standard part of the identifier.

Bit 1:0 = **EXID[17:16]** *Extended Identifier*

2 most significant bits of the extended part of the identifier.

MIDR2

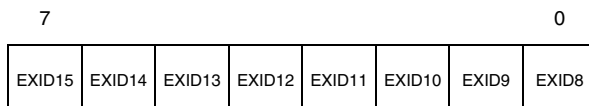

Bit 7:0 = **EXID[15:8]** *Extended Identifier*

Bit 15 to 8 of the extended part of the identifier.

MIDR3

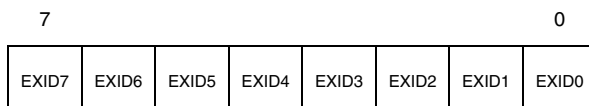

Bit 7:1 = **EXID[6:0]** *Extended Identifier*

6 least significant bits of the extended part of the identifier.

CONTROLLER AREA NETWORK (Cont'd)

MAILBOX DATA LENGTH CONTROL REGISTER (MDLC)

All bits of this register is write protected when the mailbox is not in empty state.

Read / Write

Reset Value: xxxx xxxx (xxh)

7							0
TGT	0	0	0	DLC3	DLC2	DLC1	DLC0

Bit 7 = **TGT** *Transmit Global Time*

This bit is active only when the hardware is in the Time Trigger Communication mode, TTCM bit of the CCR register is set.

0: MTSRH and MTSRL registers are not sent.

1: MTSRH and MTSRL registers are sent in the last two data bytes of the message.

6:4 = Reserved. Forced to 0 by hardware.

Bit 3:0 = **DLC[3:0]** *Data Length Code*

This field defines the number of data bytes a data frame contains or a remote frame request.

MAILBOX DATA REGISTERS (MDAR[7:0])

All bits of this register are write protected when the mailbox is not in empty state.

Read / Write

Reset Value: xxxx xxxx (xxh)

7							0
DATA7	DATA6	DATA5	DATA4	DATA3	DATA2	DATA1	DATA0

Bit 7:0 = **DATA[7:0]** *Data*

A data byte of the message. A message can contain from 0 to 8 data bytes.

MAILBOX TIME STAMP LOW REGISTER (MTSLR)

Read / Write

Reset Value: xxxx xxxx (xxh)

7							0
TIME7	TIME6	TIME5	TIME4	TIME3	TIME2	TIME1	TIME0

Bit 7:0 = **TIME[7:0]** *Message Time Stamp Low*
This fields contains the low byte of the 16-bit timer value captured at the SOF detection.

MAILBOX TIME STAMP HIGH REGISTER (MTSHR)

Read / Write

Reset Value: xxxx xxxx (xxh)

7							0
TIME15	TIME14	TIME13	TIME12	TIME11	TIME10	TIME9	TIME8

Bit 7:0 = **TIME[15:8]** *Message Time Stamp High*
This field contains the high byte of the 16-bit timer value captured at the SOF detection.

CONTROLLER AREA NETWORK (Cont'd)

10.10.8.3 CAN Filter Registers

CAN FILTER CONFIGURATION REG.0 (CFCR0)

All bits of this register are set and cleared by software.

Read / Write

Reset Value: 0000 0000 (00h)

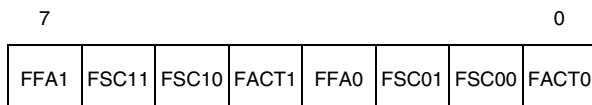

Note: To modify the FFAx and FSCx bits, the bxCAN must be in INIT mode.

Bit 7 = **FFA1** Filter FIFO Assignment for Filter 1

The message passing through this filter will be stored in the specified FIFO.

0: Filter assigned to FIFO 0

1: Filter assigned to FIFO 1

Bit 6:5 = **FSC1[1:0]** Filter Scale Configuration

These bits define the scale configuration of Filter 1.

Bit 4 = **FACT1** Filter Active

The software sets this bit to activate Filter 1. To modify the Filter 1 registers (CF1R[7:0]), the FACT1 bit must be cleared.

0: Filter 1 is not active

1: Filter 1 is active

Bit 3 = **FFA0** Filter FIFO Assignment for Filter 0

The message passing through this filter will be stored in the specified FIFO.

0: Filter assigned to FIFO 0

1: Filter assigned to FIFO 1

Bit 2:1 = **FSC0[1:0]** Filter Scale Configuration

These bits define the scale configuration of Filter 0.

Bit 0 = **FACT0** Filter Active

The software sets this bit to activate Filter 0. To modify the Filter 0 registers (CF0R[0:7]), the FACT0 bit must be cleared.

0: Filter 0 is not active

1: Filter 0 is active

CAN FILTER CONFIGURATION REG.1 (CFCR1)

All bits of this register are set and cleared by software.

Read / Write

Reset Value: 0000 0000 (00h)

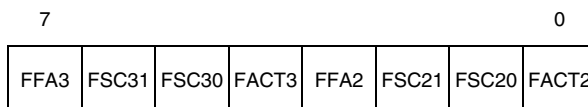

Bit 7 = **FFA3** Filter FIFO Assignment for Filter 3

The message passing through this filter will be stored in the specified FIFO.

0: Filter assigned to FIFO 0

1: Filter assigned to FIFO 1

Bit 6:5 = **FSC3[1:0]** Filter Scale Configuration

These bits define the scale configuration of Filter 3.

Bit 4 = **FACT3** Filter Active

The software sets this bit to activate filter 3. To modify the Filter 3 registers (CF3R[0:7]) the FACT3 bit must be cleared.

0: Filter 3 is not active

1: Filter 3 is active

Bit 3 = **FFA2** Filter FIFO Assignment for Filter 2

The message passing through this filter will be stored in the specified FIFO.

0: Filter assigned to FIFO 0

1: Filter assigned to FIFO 1

Bit 2:1 = **FSC2[1:0]** Filter Scale Configuration

These bits define the scale configuration of Filter 2.

Bit 0 = **FACT2** Filter Active

The software sets this bit to activate Filter 2. To modify the Filter 2 registers (CF2R[0:7]), the FACT2 bit must be cleared.

0: Filter 2 is not active

1: Filter 2 is active

CONTROLLER AREA NETWORK (Cont'd)

CAN FILTER CONFIGURATION REG.2 (CFCR2)

All bits of this register are set and cleared by software.

Read / Write

Reset Value: 0000 0000 (00h)

7	0						
FFA5	FSC51	FSC50	FACT5	FFA4	FSC41	FSC40	FACT4

Note: To modify FFAx and FSCx bits bxCAN must be in INIT mode.

Bit 7 = **FFA5** *Filter FIFO Assignment for Filter 5*

The message passing through this filter will be stored in the specified FIFO.

0: Filter assigned to FIFO 0

1: Filter assigned to FIFO 1

Bit 6:5 = **FSC5[1:0]** *Filter Scale Configuration*

These bits define the scale configuration of Filter 5.

Bit 4 = **FACT5** *Filter Active*

The software sets this bit to activate Filter 5. To modify the filter 5 registers (CF5R[7:0]), the FACT5 bit must be cleared.

0: Filter 5 is not active

1: Filter 5 is active

Bit 3 = **FFA4** *Filter FIFO Assignment for Filter 4*

The message passing through this filter will be stored in the specified FIFO.

0: Filter assigned to FIFO 0

1: Filter assigned to FIFO 1

Bit 2:1 = **FSC4[1:0]** *Filter Scale Configuration*

These bits define the scale configuration of Filter 4.

Bit 0 = **FACT4** *Filter Active*

The software sets this bit to activate filter 4. To modify the Filter 4 registers (CF4R[7:0]), the FACT4 bit must be cleared.

0: Filter 4 is not active

1: Filter 4 is active

CAN FILTER CONFIGURATION REG.3 (CFCR3)

All bits of this register are set and cleared by software.

Read / Write

Reset Value: 0000 0000 (00h)

7	0						
FFA7	FSC71	FSC70	FACT7	FFA6	FSC61	FSC60	FACT6

Bit 7 = **FFA7** *Filter FIFO Assignment for Filter 7*

The message passing through this filter will be stored in the specified FIFO.

0: Filter assigned to FIFO 0

1: Filter assigned to FIFO 1

Bit 6:5 = **FSC7[1:0]** *Filter Scale Configuration*

These bits define the scale configuration of Filter 7.

Bit 4 = **FACT7** *Filter Active*

The software sets this bit to activate Filter 7. To modify the Filter 7 registers (CF7R[7:0]), the FACT7 bit must be cleared.

0: Filter 7 is not active.

1: Filter 7 is active.

Bit 3 = **FFA6** *Filter FIFO Assignment for Filter 6*

This bit allows the software to define whether the message passing through this filter will be assigned to the receive FIFO0 or FIFO1.

0: Filter assigned to FIFO 0

1: Filter assigned to FIFO 1

Bit 2:1 = **FSC6[1:0]** *Filter Scale Configuration*

These bits define the scale configuration of Filter 6.

Bit 0 = **FACT6** *Filter Active*

The software sets this bit to activate Filter 6. To modify the Filter 6 registers (CF6R[7:0]), the FACT6 bit must be cleared.

0: Filter 6 is not active

1: Filter 6 is active

CONTROLLER AREA NETWORK (Cont'd)

CAN FILTER MODE REG.1 (CFMR1)

All bits of this register are set and cleared by software.

Read / Write

Reset Value: 0000 0000 (00h)

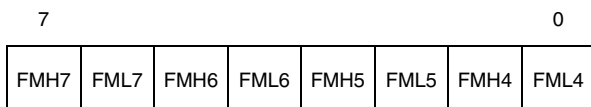

Note: Please refer to [Figure 149.Filter Bank Scale Configuration - Register Organisation](#)

Bit 7 = **FMH7 Filter Mode High**
 Mode of the high registers of Filter 7.
 0: High registers are in mask mode.
 1: High registers are in identifier list mode.

Bit 6 = **FML7 Filter Mode Low**
 Mode of the low registers of Filter 7.
 0: Low registers are in mask mode
 1: Low registers are in identifier list mode

Bit 5 = **FMH6 Filter Mode High**
 Mode of the high registers of Filter 6.
 0: High registers are in mask mode
 1: High registers are in identifier list mode

Bit 4 = **FML6 Filter Mode Low**
 Mode of the low registers of Filter 6.
 0: Low registers are in mask mode
 1: Low registers are in identifier list mode

Bit 3 = **FMH5 Filter Mode High**
 Mode of the high registers of filter 5.
 0: High registers are in mask mode
 1: High registers are in identifier list mode

Bit 2 = **FML5 Filter Mode Low**
 Mode of the low registers of Filter 5.
 0: Low registers are in mask mode
 1: Low registers are in identifier list mode.

Bit 1 = **FMH4 Filter Mode High**
 Mode of the high registers of filter 4.
 0: High registers are in mask mode.
 1: High registers are in identifier list mode.

Bit 0 = **FML4 Filter Mode Low**
 Mode of the low registers of filter 4.
 0: Low registers are in mask mode.
 1: Low registers are in identifier list mode.

CAN FILTER MODE REG.0 (CFMR0)

All bits of this register are set and cleared by software.

Read / Write

Reset Value: 0000 0000 (00h)

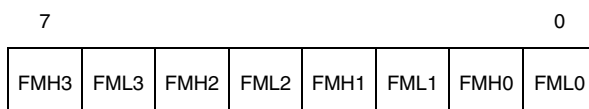

Bit 7 = **FMH3 Filter Mode High**
 Mode of the high registers of Filter 3.
 0: High registers are in mask mode
 1: High registers are in identifier list mode

Bit 6 = **FML3 Filter Mode Low**
 Mode of the low registers of Filter 3.
 0: Low registers are in mask mode
 1: Low registers are in identifier list mode

Bit 5 = **FMH2 Filter Mode High**
 Mode of the high registers of Filter 2.
 0: High registers are in mask mode
 1: High registers are in identifier list mode

Bit 4 = **FML2 Filter Mode Low**
 Mode of the low registers of Filter 2.
 0: Low registers are in mask mode
 1: Low registers are in identifier list mode

Bit 3 = **FMH1 Filter Mode High**
 Mode of the high registers of Filter 1.
 0: High registers are in mask mode
 1: High registers are in identifier list mode

CONTROLLER AREA NETWORK (Cont'd)

Bit 2 = **FML1** *Filter Mode Low*

Mode of the low registers of filter 1.

0: Low registers are in mask mode

1: Low registers are in identifier list mode

Bit 1 = **FMH0** *Filter Mode High*

Mode of the high registers of filter 0.

0: High registers are in mask mode

1: High registers are in identifier list mode

Bit 0 = **FML0** *Filter Mode Low*

Mode of the low registers of filter 0.

0: Low registers are in mask mode

1: Low registers are in identifier list mode

FILTER x REGISTER[7:0] (CFxR[7:0])

Read / Write

Reset Value: xxxx xxxx (xxh)

7							0
FB7	FB6	FB5	FB4	FB3	FB2	FB1	FB0

In all configurations:

Bit 7:0 = **FB[7:0]** *Filter Bits*

Identifier

Each bit of the register specifies the level of the corresponding bit of the expected identifier.

0: Dominant bit is expected

1: Recessive bit is expected

Mask

Each bit of the register specifies whether the bit of the associated identifier register must match with the corresponding bit of the expected identifier or not.

0: Don't care, the bit is not used for the comparison

1: Must match, the bit of the incoming identifier must have the same level has specified in the corresponding identifier register of the filter.

Note: Each filter x is composed of 8 registers, CFxR[7:0]. Depending on the scale and mode configuration of the filter the function of each register can differ. For the filter mapping, functions description and mask registers association, refer to Section [10.10.5.4 Identifier Filtering](#).

A Mask/Identifier register in **mask mode** has the same bit mapping as in **identifier list** mode.

Note: To modify these registers, the corresponding FACT bit in the CFCR register must be cleared.

CONTROLLER AREA NETWORK (Cont'd)

10.10.8.4 Page Mapping for CAN 0 / CAN 1

	PAGE 48 / 36	PAGE 49 / 37	PAGE 50 / 38	PAGE 51 / 39	PAGE 52 / 40
240	CMCR	MFMI	MFMI	MCSR	MCSR
241	CMSR	MDLC	MDLC	MDLC	MDLC
242	CTSR	MIDR0	MIDR0	MIDR0	MIDR0
243	CTPR	MIDR1	MIDR1	MIDR1	MIDR1
244	CRFR0	MIDR2	MIDR2	MIDR2	MIDR2
245	CRFR1	MIDR3	MIDR3	MIDR3	MIDR3
246	CIER	MDAR0	MDAR0	MDAR0	MDAR0
247	CESR	MDAR1	MDAR1	MDAR1	MDAR1
248	CEIER	MDAR2	MDAR2	MDAR2	MDAR2
249	TEC	MDAR3	MDAR3	MDAR3	MDAR3
250	REC	MDAR4	MDAR4	MDAR4	MDAR4
251	CDGR	MDAR5	MDAR5	MDAR5	MDAR5
252	CBTR0	MDAR6	MDAR6	MDAR6	MDAR6
253	CBTR1	MDAR7	MDAR7	MDAR7	MDAR7
254	Reserved	MTSLR	MTSLR	MTSLR	MTSLR
255	CFPSR	MTSHR	MTSHR	MTSHR	MTSHR
	Control/Status	Receive FIFO 0	Receive FIFO 1	Tx Mailbox 0	Tx Mailbox 1
	PAGE 53 / 41	PAGE 54/4 42/4	PAGE 54/0 42/0	PAGE 54/1 42/1	PAGE 54/2 42/2
240	MCSR	CFMR0	CF0R0	CF2R0	CF4R0
241	MDLC	CFMR1	CF0R1	CF2R1	CF4R1
242	MIDR0	CFCR0	CF0R2	CF2R2	CF4R2
243	MIDR1	CFCR1	CF0R3	CF2R3	CF4R3
244	MIDR2	CFCR2	CF0R4	CF2R4	CF4R4
245	MIDR3	CFCR3	CF0R5	CF2R5	CF4R5
246	MDAR0	Reserved	CF0R6	CF2R6	CF4R6
247	MDAR1	Reserved	CF0R7	CF2R7	CF4R7
248	MDAR2	Reserved	CF1R0	CF3R0	CF5R0
249	MDAR3	Reserved	CF1R1	CF3R1	CF5R1
250	MDAR4	Reserved	CF1R2	CF3R2	CF5R2
251	MDAR5	Reserved	CF1R3	CF3R3	CF5R3
252	MDAR6	Reserved	CF1R4	CF3R4	CF5R4
253	MDAR7	Reserved	CF1R5	CF3R5	CF5R5
254	MTSLR	Reserved	CF1R6	CF3R6	CF5R6
255	MTSHR	Reserved	CF1R7	CF3R7	CF5R7
	Tx Mailbox 2	Filter Configuration	Acceptance Filter 0:1	Acceptance Filter 2:3	Acceptance Filter 4:5

CONTROLLER AREA NETWORK (Cont'd)

Page Mapping for CAN0 /CAN1 (Cont'd)

PAGE 54/3 42/3

240	CF6R0
241	CF6R1
242	CF6R2
243	CF6R3
244	CF6R4
245	CF6R5
246	CF6R6
247	CF6R7
248	CF7R0
249	CF7R1
250	CF7R2
251	CF7R3
252	CF7R4
253	CF7R5
254	CF7R6
255	CF7R7

Acceptance Filter 6:7

CONTROLLER AREA NETWORK (Cont'd)

Table 65. bxCAN Control & Status Page - Register Map and Reset Values

Address (Hex.)	Register Name	7	6	5	4	3	2	1	0
F0h	CMCR Reset Value	TTCM 0	ABOM 0	AWUM 0	NART 0	RFLM 0	TXFP 0	SLEEP 1	INRQ 0
F1h	CMSR Reset Value	0	0	REC 0	TRAN 0	WKUI 0	ERRI 0	SLAK 0	INAK 0
F2h	CTSR Reset Value	0	TXOK2 0	TXOK1 0	TXOK0 0	0	RQCP2 0	RQCP1 0	RQCP0 0
F3h	CTPR Reset Value	LOW2 0	LOW1 0	LOW0 0	TME2 1	TME1 1	TME0 1	CODE1 0	CODE0 0
F4h	CRFR0 Reset Value	0	0	RFOM 0	FOVR 0	FULL 0	0	FMP1 0	FMP0 0
F5h	CRFR1 Reset Value	0	0	RFOM 0	FOVR 0	FULL 0	0	FMP1 0	FMP0 0
F6h	CIER Reset Value	WKUIE 0	FOVIE1 0	FFIE1 0	FMPIE1 0	FOVIE0 0	FFIE0 0	FMPIE0 0	TMEIE 0
F7h	CESR Reset Value	0	LEC2 0	LEC1 0	LEC0 0	0	BOFF 0	EPVF 0	EWGF 0
F8h	CEIER Reset Value	ERRIE 0	0	0	0	LECIE 0	BOFIE 0	EPVIE 0	EWGIE 0
F9h	TECR Reset Value	TEC7 0	TEC6 0	TEC5 0	TEC4 0	TEC3 0	TEC2 0	TEC1 0	TEC0 0
FAh	RECR Reset Value	REC7 0	REC6 0	REC5 0	REC4 0	REC3 0	REC2 0	REC1 0	REC0 0
FBh	CDGR Reset Value	0	0	0	0	RX 0	SAMP 0	SILM 0	LBKM 0
FCh	CBTR0 Reset Value	SJW1 0	SJW0 0	BRP5 0	BRP4 0	BRP3 0	BRP2 0	BRP1 0	BRP0 0
FDh	CBTR1 Reset Value	0	TS22 0	TS21 1	TS20 0	TS13 0	TS12 0	TS11 1	TS10 1
FEh	Reserved	X	X	X	X	X	X	X	X
FFh	CFPSR Reset Value	0	0	0	0	0	FPS2 0	FPS1 0	FPS0 0

CONTROLLER AREA NETWORK (bxCAN)

CONTROLLER AREA NETWORK (Cont'd)

Table 66. bxCAN Mailbox Pages - Register Map and Reset Values

Address (Hex.)	Register Name	7	6	5	4	3	2	1	0
F0h Receive	MFMI Reset Value	FMI7 0	FMI6 0	FMI5 0	FMI4 0	FMI3 0	FMI2 0	FMI1 0	FMI0 0
F0h Transmit	MCSR Reset Value	0	0	TERR 0	ALST 0	TXOK 0	RQCP 0	ABRQ 1	TXRQ 0
F1h	MDLC Reset Value	TGT x	x	x	x	DLC3 x	DLC2 x	DLC1 x	DLC0 x
F2h	MIDR0 Reset Value	x	IDE x	RTR x	STID10 x	STID9 x	STID8 x	STID7 x	STID6 x
F3h	MIDR1 Reset Value	STID5 x	STID4 x	STID3 x	STID2 x	STID1 x	STID0 x	EXID17 x	EXID16 x
F4h	MIDR2 Reset Value	EXID15 x	EXID14 x	EXID13 x	EXID12 x	EXID11 x	EXID10 x	EXID9 x	EXID8 x
F5h	MIDR3 Reset Value	EXID7 x	EXID6 x	EXID5 x	EXID4 x	EXID3 x	EXID2 x	EXID1 x	EXID0 x
F6h:FDh	MDAR[0:7] Reset Value	MDAR7 x	MDAR6 x	MDAR5 x	MDAR4 x	MDAR3 x	MDAR2 x	MDAR1 x	MDAR0 x
FEh	MTSLR Reset Value	TIME7 x	TIME6 x	TIME5 x	TIME4 x	TIME3 x	TIME2 x	TIME1 x	TIME0 x
FFh	MTSHR Reset Value	TIME15 x	TIME14 x	TIME13 x	TIME12 x	TIME11 x	TIME10 x	TIME9 x	TIME8 x

Table 67. bxCAN Filter Configuration Page - Register Map and Reset Values

Address (Hex.)	Register Name	7	6	5	4	3	2	1	0
F0h	CFMR0 Reset Value	FMH3 0	FML3 0	FMH2 0	FML2 0	FMH1 0	FML1 0	FMH0 0	FML0 0
F1h	CFMR1 Reset Value	FMH7 0	FML7 0	FMH6 0	FML6 0	FMH5 0	FML5 0	FMH4 0	FML4 0
F2h	CFCR0 Reset Value	FFA1 0	FSC11 0	FSC10 0	FACT1 0	FFA0 0	FSC01 0	FSC00 0	FACT0 0
F3h	CFCR1 Reset Value	FFA3 0	FSC31 0	FSC30 0	FACT3 0	FFA2 0	FSC21 0	FSC20 0	FACT2 0
F4h	CFCR2 Reset Value	FFA5 0	FSC51 0	FSC50 0	FACT5 0	FFA4 0	FSC41 0	FSC40 0	FACT4 0
F5h	CFCR3 Reset Value	FFA7 0	FSC71 0	FSC70 0	FACT7 0	FFA6 0	FSC61 0	FSC60 0	FACT6 0

CONTROLLER AREA NETWORK (Cont'd)

10.10.9 IMPORTANT NOTES ON CAN

Refer to [Section 13.4 on page 413](#) and [Section 13.6 on page 414](#).

10.11 10-BIT ANALOG TO DIGITAL CONVERTER (ADC)

10.11.1 Main Characteristics

- 10-bit Resolution
- Monotonicity: Guaranteed
- No missing codes: Guaranteed
- 3-bit INTCLK/2 Frequency Prescaler
- Internal/External Trigger availability
- Continuous/Single Modes
- Autoscan Mode
- Power Down Mode
- 16 10-bit data registers (two per channel)
- Two analog watchdogs selectable on adjacent channels

10.11.2 Introduction

The Analog to Digital Converter (ADC) consists of an input multiplex channel selector feeding a successive approximation converter.

The conversion time depends on the INTCLK frequency and the prescaler factor stored in the PR[2:0] bits of the CLR2 register (R253-page 63)).

AV_{DD} and AV_{SS} are the high and low level reference voltage pins. Up to 16 multiplexed Analog Inputs are available depending on the specific device type. With the AUTOSCAN feature, a group of signals can be converted sequentially by simply programming the starting address of the first analog channel to be converted.

There are two Analog Watchdogs used for the continuous hardware monitoring of two consecutive input channels selectable by means of the CC[3:0] bits in the CLR1 register (R252-page 63). An Interrupt request is generated whenever the converted value of either of these two analog inputs exceeds the upper or lower programmed threshold values.

Figure 155. ADC Block Diagram

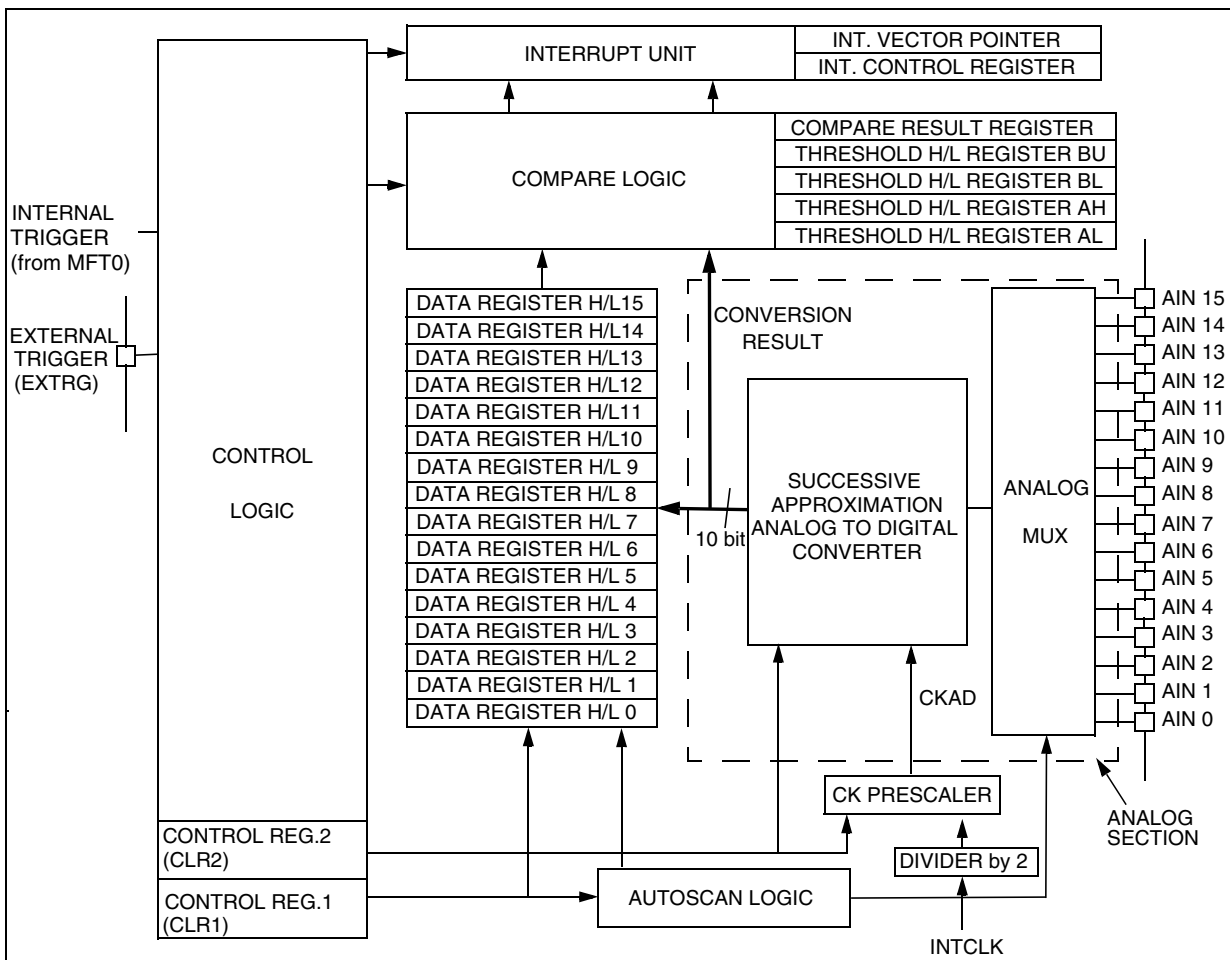

ANALOG TO DIGITAL CONVERTER (Cont'd)

Single and continuous conversion modes are available. These two modes may be triggered by an external signal or, internally, by the Multifunction Timer MFT0.

A Power-Down programmable bit allows the ADC to be set in low-power idle mode.

The reference voltage AV_{DD} can be switched off when the ADC is in power down mode.

The ADC Interrupt Unit provides two maskable channels (Analog Watchdog and End of Conversion) with hardware fixed priority, and up to 7 programmable priority levels.

Conversion Time

The maximum CKAD frequency allowable for the analog part is 4 MHz. This is provided by a programmable prescaler that divides the ST9 system clock (INTCLK) and a divider by 2. The user must program the PR[2:0] bits in Control Logic Register 2 (CLR2, R253 - Page 63) to select the right prescaler dividing factor to obtain the correct clock frequency for the analog part. Table 69 shows the possible prescaling values and the related sampling and conversion times. Generally, the formulas for the sampling and conversion times are:

$$T_{\text{Sample}} = (T_{\text{INTCLK}} \times 2) \times (\text{PR}[2:0] \times 8)$$

$$T_{\text{Conv}} = (T_{\text{INTCLK}} \times 2) \times (\text{PR}[2:0] \times 28)$$

The user may need to increase the conversion time if a resistor is added to the input pin, for instance, as an overvoltage protection. In this case, the ADC needs a longer sampling time to work correctly.

CAUTION: ADC INPUT PIN CONFIGURATION

The input Analog channel is selected by using the I/O pin Alternate Function setting (PxC2, PxC1, PxC0 = 1,1,1) as described in the I/O ports section. The I/O configuration of the port connected to the ADC converter is modified in order to prevent the analog voltage present on the I/O pin from causing high power dissipation across the input buffer. Analog channels should be maintained in Alternate Function configuration for this reason.

10.11.3 Functional Description**10.11.3.1 Operating Modes**

Two operating modes are available: Continuous Mode and Single Mode. To enter one of these modes it is necessary to program the CONT bit of the Control Logic Register2 (CLR2, R253-page63). The Continuous Mode is selected when CONT is set, while Single Mode is selected when CONT is reset.

Both modes operate in AUTOSCAN configuration, allowing sequential conversion of the input channels. The number of analog inputs to be converted may be set by software, by setting the number of the first channel to be converted into Control Register 1 (SC[3:0] bits). As each conversion is completed, the channel number is automatically incremented, up to channel 15. For example, if SC[3:0] are set to 0011, the conversion will proceed from channel 3 to channel 15, whereas, if SC[3:0] are set to 1111, only channel 15 will be converted.

When the ST bit of Control Logic Register 2 is set, either by software or by hardware (by an internal or external synchronisation trigger signal), the analog inputs are sequentially converted (from the first selected channel up to channel 15) and the results are stored in the relevant pair of Data Registers.

In **Single Mode** (CONT = "0"), the ST bit is reset by hardware following conversion of channel 15; an End of Conversion (ECV) interrupt request is issued and the ADC waits for a new start event.

In **Continuous Mode** (CONT = "1"), a continuous conversion flow is initiated by the start event. When conversion of channel 15 is complete, conversion of channel 's' is initiated (where 's' is specified by the setting of the SC[3:0] bits); this will continue until the ST bit is reset by software. In all cases, an ECV interrupt is issued each time channel 15 conversion ends.

When channel 'i' is converted ('s' < 'i' < 15), the related pair of Data Registers is reloaded with the new conversion result and the previous value is lost. The End of Conversion (ECV) interrupt service routine can be used to save the current values before a new conversion sequence (so as to create signal sample tables in the Register File or in Memory).

10.11.3.2 Triggering and Synchronisation

In both modes, conversion may be triggered by internal or external conditions; externally this may be tied to EXTRG, as an Alternate Function input on an I/O port pin, and internally, it may be tied to INTRG, generated by a Multifunction Timer peripheral. Both external and internal events can be separately masked by programming the EXTG/INTG bits of the Control Logic Register (CLR). The events are internally ORed, thus avoiding potential hardware conflicts. However, the correct procedure is to enable only one alternate synchronisation condition at any time.

ANALOG TO DIGITAL CONVERTER (Cont'd)

The effect of either of these synchronisation modes is to set the ST bit by hardware. This bit is reset, in Single Mode only, at the end of each group of conversions. In Continuous Mode, all trigger pulses after the first are ignored.

The synchronisation sources must be at a logic low level for at least the duration of two INTCLK cycles and, in Single Mode, the period between trigger pulses must be greater than the total time required for a group of conversions. If a trigger occurs when the ST bit is still set, i.e. when a conversion is still in progress, it will be ignored.

Note: The external trigger will set the CLR2.ST bit even if the CLR2.POW is reset.

10.11.3.3 Analog Watchdog

Two internal Analog Watchdogs are available for highly flexible automatic threshold monitoring of external analog signal levels. Depending on the value of the CC[3:0] bits in Control Logic Register1 these two watchdog are mapped onto 2 of the 16 available adjacent channels, allowing the user to set the channel to be monitored. Refer to [Table 68](#) to see the possible choices for this feature.

Analog watchdog channels (named as A and B) monitor an acceptable voltage level window for the converted analog inputs. The external voltages applied to inputs A and B are considered normal while they remain below their respective Upper thresholds, and above or at their respective Lower thresholds.

When the external signal voltage level is greater than, or equal to, the upper programmed voltage limit, or when it is less than the lower programmed voltage limit, a maskable interrupt request is generated and the Compare Results Register is updated in order to flag the threshold (Upper or Lower) and channel (A or B) responsible for the inter-

Figure 157. ADC Trigger Source

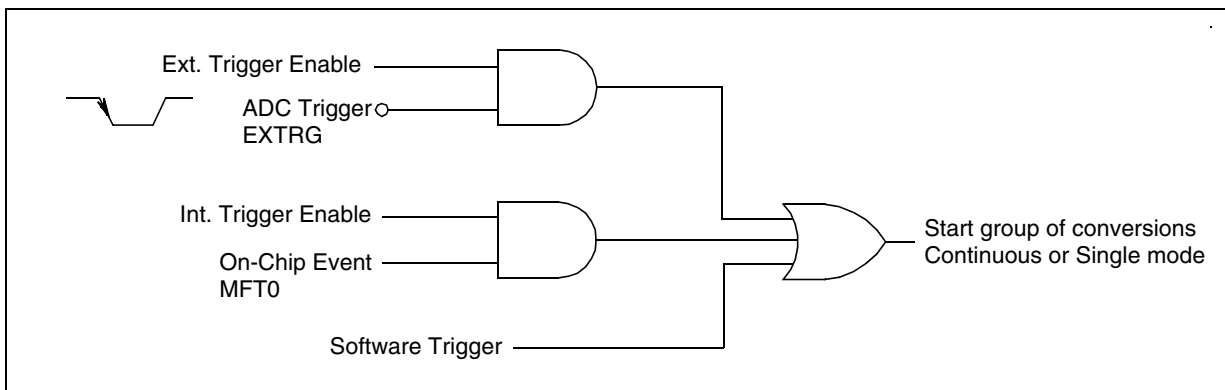

rupt. The four threshold voltages are user programmable in dedicated registers pairs (R244 to R251, page 63). Only the 4 MSBs of the Compare Results Register are used as flags, each of the four MSBs being associated with a threshold condition.

Following a reset, these flags are reset. During normal ADC operation, the CRR bits are set, in order to flag an out of range condition and are automatically reset by hardware after a software reset of the Analog Watchdog Request flag in the ICR Register.

10.11.3.4 Power Down Mode

Before enabling an ADC conversion, the POW bit of the Control Logic Register must be set; this must be done at least 10 μs before the first conversion start, in order to correctly bias the analog section of the converter circuitry.

When the ADC is not required, the POW bit may be reset in order to reduce the total power consumption. This is the reset configuration, and this state is also selected automatically when the ST9 is placed in Halt Mode (following the execution of the halt instruction).

Figure 156. Analog Watchdog Function

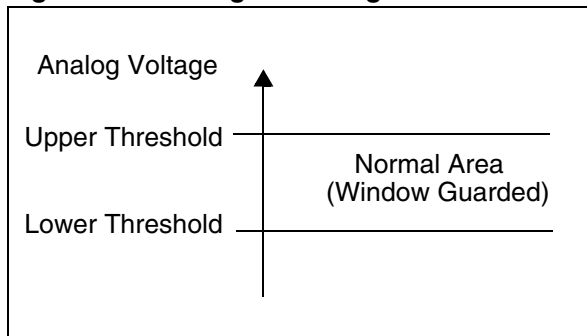

ANALOG TO DIGITAL CONVERTER (Cont'd)

Figure 158. Application Example: Analog Watchdog used in Motor Speed Control

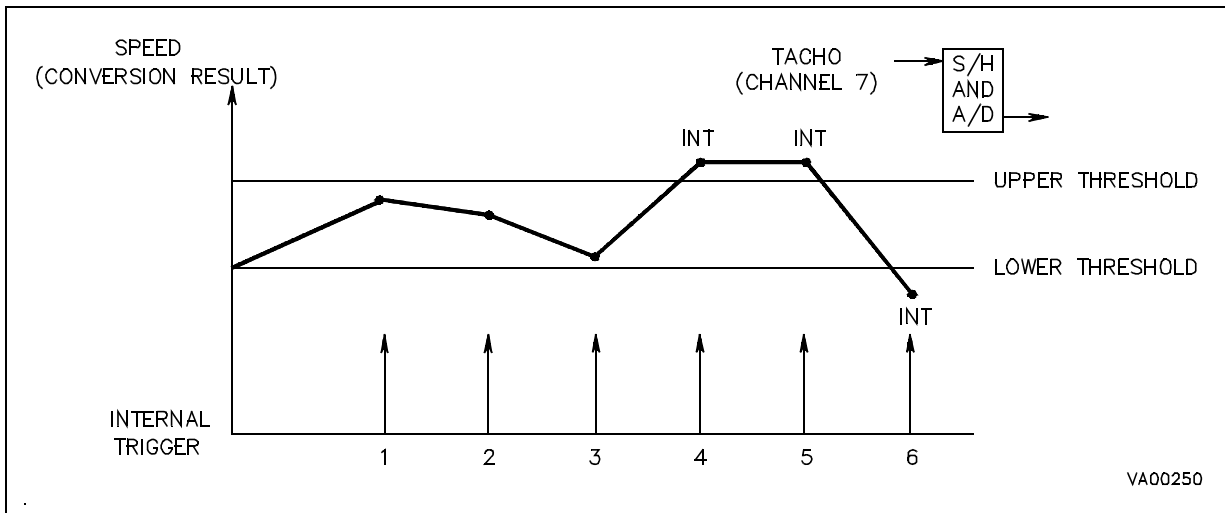

10.11.4 Interrupts

The ADC provides two interrupt sources:

- End of Conversion
- Analog Watchdog Request

The ADC Interrupt Vector Register (IVR, R255 Page 63) provides hardware generated flags which indicate the interrupt source, thus allowing the automatic selection of the correct interrupt service routine.

the Interrupt Vector table containing the base address of the four byte area of the interrupt vector table in which the address of the ADC interrupt service routines are stored.

The Analog Watchdog Interrupt Pending bit (AWD, ICR.6) is automatically set by hardware whenever any of the two guarded analog inputs go out of range. The Compare Result Register (CRR) tracks the analog inputs which exceed their programmed thresholds.

When two requests occur simultaneously, the Analog Watchdog Request has priority over the End of Conversion request, which is held pending.

The Analog Watchdog Request requires the user to poll the Compare Result Register (CRR) to determine which of the four thresholds has been exceeded. The threshold status bits are set to flag an out of range condition, and are automatically reset by hardware after a software reset of the Analog Watchdog Request flag in the ICR Register. The interrupt pending flags, ECV and AWD, should be reset by the user within the interrupt service routine. Setting either of these two bits by software will cause an interrupt request to be generated.

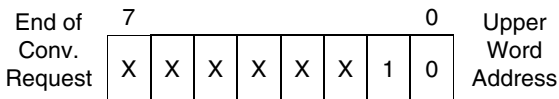
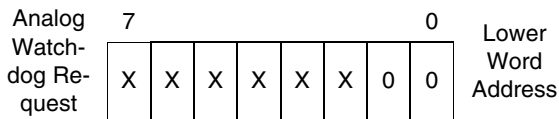

The ADC Interrupt vector should be programmed by the user to point to the first memory location in

10.11.5 Register Description

DATA REGISTERS (DiHR/DiLR)

The conversion results for the 16 available channels are loaded into the 32 Data Registers (two for each channel) following conversion of the corresponding analog input.

CHANNEL 0 DATA HIGH REGISTER (D0HR)

R240 - Read/Write
Register Page: 61
Reset Value: undefined

7							0
D0.9	D0.8	D0.7	D0.6	D0.5	D0.4	D0.3	D0.2

Bits 7:0 = **D0.[9:2]**: Channel 0 9:2 bit Data

CHANNEL 0 DATA LOW REGISTER (D0LR)

R241 - Read/Write
Register Page: 61
Reset Value: xx00 0000

7							0
D0.1	D0.0	0	0	0	0	0	0

Bits 7:6 = **D0.[1:0]**: Channel 0 1:0 bit Data

Bits 5:0 = Reserved, forced by hardware to 0.

CHANNEL 1 DATA HIGH REGISTER (D1HR)

R242 - Read/Write
Register Page: 61
Reset Value: undefined

7							0
D1.9	D1.8	D1.7	D1.6	D1.5	D1.4	D1.3	D1.2

Bits 7:0 = **D1.[9:2]**: Channel 1 9:2 bit Data

CHANNEL 1 DATA LOW REGISTER (D1LR)

R243 - Read/Write
Register Page: 61
Reset Value: xx00 0000

7							0
D1.1	D1.0	0	0	0	0	0	0

Bits 7:0 = **D1.[1:0]**: Channel 1 1:0 bit Data

Bits 5:0 = Reserved, forced by hardware to 0.

CHANNEL 2 DATA HIGH REGISTER (D2HR)

R244 - Read/Write
Register Page: 61
Reset Value: undefined

7							0
D2.9	D2.8	D2.7	D2.6	D2.5	D2.4	D2.3	D2.2

Bits 7:0 = **D2.[9:2]**: Channel 2 9:2 bit Data

CHANNEL 2 DATA LOW REGISTER (D2LR)

R245 - Read/Write
Register Page: 61
Reset Value: xx00 0000

7							0
D2.1	D2.0	0	0	0	0	0	0

Bits 7:0 = **D2.[1:0]**: Channel 2 1:0 bit Data

Bits 5:0 = Reserved, forced by hardware to 0.

CHANNEL 3 DATA HIGH REGISTER (D3HR)

R246 - Read/Write
Register Page: 61
Reset Value: undefined

7							0
D3.9	D3.8	D3.7	D3.6	D3.5	D3.4	D3.3	D3.2

Bits 7:0 = **D3.[9:2]**: Channel 3 9:2 bit Data

CHANNEL 3 DATA LOW REGISTER (D3LR)

R247 - Read/Write
Register Page: 61
Reset Value: xx00 0000

7							0
D3.1	D3.0	0	0	0	0	0	0

Bits 7:0 = **D3.[1:0]**: Channel 3 1:0 bit Data

Bits 5:0 = Reserved, forced by hardware to 0.

10-BIT ANALOG TO DIGITAL CONVERTER (ADC)

REGISTER DESCRIPTION (Cont'd)

CHANNEL 8 DATA HIGH REGISTER (D8HR)

R240 - Read/Write
Register Page: 62
Reset Value: undefined

7							0
D8.9	D8.8	D8.7	D8.6	D8.5	D8.4	D8.3	D8.2

Bits 7:0 = **D8.[9:2]**: Channel 8 9:2 bit Data

CHANNEL 8 DATA LOW REGISTER (D8LR)

R241 - Read/Write
Register Page: 62
Reset Value: xx00 0000

7							0
D8.1	D8.0	0	0	0	0	0	0

Bits 7:6 = **D8.[1:0]**: Channel 8 1:0 bit Data

Bits 5:0 = Reserved, forced by hardware to 0.

CHANNEL 9 DATA HIGH REGISTER (D9HR)

R242 - Read/Write
Register Page: 62
Reset Value: undefined

7							0
D9.9	D9.8	D9.7	D9.6	D9.5	D9.4	D9.3	D9.2

Bits 7:0 = **D9.[9:2]**: Channel 9 9:2 bit Data

CHANNEL 9 DATA LOW REGISTER (D9LR)

R243 - Read/Write
Register Page: 62
Reset Value: xx00 0000

7							0
D9.1	D9.0	0	0	0	0	0	0

Bits 7:0 = **D9.[1:0]**: Channel 9 1:0 bit Data

Bits 5:0 = Reserved, forced by hardware to 0.

CHANNEL 10 DATA HIGH REGISTER (D10HR)

R244 - Read/Write
Register Page: 62
Reset Value: undefined

7							0
D10.9	D10.8	D10.7	D10.6	D10.5	D10.4	D10.3	D10.2

Bits 7:0 = **D10.[9:2]**: Channel 10 9:2 bit Data

CHANNEL 10 DATA LOW REGISTER (D10LR)

R245 - Read/Write
Register Page: 62
Reset Value: xx00 0000

7							0
D10.1	D10.0	0	0	0	0	0	0

Bits 7:0 = **D10.[1:0]**: Channel 10 1:0 bit Data

Bits 5:0 = Reserved, forced by hardware to 0.

CHANNEL 11 DATA HIGH REGISTER (D11HR)

R246 - Read/Write
Register Page: 62
Reset Value: undefined

7							0
D11.9	D11.8	D11.7	D11.6	D11.5	D11.4	D11.3	D11.2

Bits 7:0 = **D11.[9:2]**: Channel 11 9:2 bit Data

CHANNEL 11 DATA LOW REGISTER (D11LR)

R247 - Read/Write
Register Page: 62
Reset Value: xx00 0000

7							0
D11.1	D11.0	0	0	0	0	0	0

Bits 7:0 = **D11.[1:0]**: Channel 11 1:0 bit Data

Bits 5:0 = Reserved, forced by hardware to 0.

REGISTER DESCRIPTION (Cont'd)

COMPARE RESULT REGISTER (CRR)

R243 - Read/Write

Register Page: 63

Reset Value: 0000 xxxx (0xh)

Two adjacent channels (identified as A and B) can be selected through CLR1 register programming (bits CC[3:0]); a level window for the converted analog input can be defined on these channels.

7							0
CBU	CAU	CBL	CAL	x	x	x	x

Bits 7 = **CBU**: *Compare Register Ch. B Upper Threshold*

Set when converted data on channel B is greater than the threshold value set in UTBHR/UTBLR registers.

Bits 6 = **CAU**: *Compare Register Ch. A Upper Threshold*

Set when converted data on channel A is greater than the threshold value set in UTAHR/UTALR registers.

Bits 5 = **CBL**: *Compare Register Ch. B Lower Threshold*

Set when converted data on channel B is less than the threshold value set in LTBHR/LTBLR registers.

Bits 4 = **CAL**: *Compare Register Ch. A Lower Threshold*

Set when converted data on channel A is less than the threshold value set in LTAHR/LTALR registers.

Bits 3:0 = Don't care

LOWER THRESHOLD REGISTERS (LTiHR/LTiLR)

The two pairs of Lower Threshold High/Low registers are used to store the user programmable lower threshold 10-bit values, to be compared with the current conversion results, thus setting the lower window limit.

CHANNEL A LOWER THRESHOLD HIGH REGISTER (LTAHR)

R244 - Read

Register Page: 63

Reset Value: undefined

7							0
LTA.9	LTA.8	LTA.7	LTA.6	LTA.5	LTA.4	LTA.3	LTA.2

Bits 7:0 = **LTA.[9:2]**: *Channel A [9:2] bit Lower Threshold*

CHANNEL A LOWER THRESHOLD LOW REGISTER (LTALR)

R245 - Read/Write

Register Page: 63

Reset Value: xx00 0000

7							0
LTA.1	LTA.0	0	0	0	0	0	0

Bits 7:6 = **LTA.[1:0]**: *Channel A [1:0] bit Lower Threshold*

Bits 5:0 = Reserved, forced by hardware to 0.

CHANNEL B LOWER THRESHOLD HIGH REGISTER (LTBHR)

R246 - Read/Write

Register Page: 63

Reset Value: undefined

7							0
LTB.7	LTB.7	LTB.5	LTB.4	LTB.3	LTB.2	LTB.1	LTB.0

Bits 7:0 = **LTB.[9:2]**: *Channel B [9:2] bit Lower Threshold*

REGISTER DESCRIPTION (Cont'd)

CHANNEL B LOWER THRESHOLD LOW REGISTER (LTBLR)

R247 - Read/Write
 Register Page: 63
 Reset Value: xx00 0000

7							0
LTB.1	LTB.0	0	0	0	0	0	0

Bits 7:6 = **LTB.[1:0]**: Channel B [1:0] bit Lower Threshold

Bits 5:0 = Reserved, forced by hardware to 0.

UPPER THRESHOLD REGISTERS (UTiHR/UTiLR)

The two pairs of Upper Threshold High/Low Registers are used to store the user programmable upper threshold 10-bit values, to be compared with the current conversion results, thus setting the upper window limit.

CHANNEL A UPPER THRESHOLD HIGH REGISTER (UTAR)

R248 - Read/Write
 Register Page: 63
 Reset Value: undefined

7							0
UTA.9	UTA.8	UTA.7	UTA.6	UTA.5	UTA.4	UTA.3	UTA.2

Bits 7:0 = **UTA.[9:2]**: Channel 6 [9:2] bit Upper Threshold value

CHANNEL A UPPER THRESHOLD LOW REGISTER (UTALR)

R249 - Read/Write
 Register Page: 63
 Reset Value: xx00 0000

7							0
UTA.1	UTA.0	0	0	0	0	0	0

Bits 7:6 = **UTA.[1:0]**: Channel A [1:0] bit Upper Threshold

Bits 5:0 = Reserved, forced by hardware to 0.

CHANNEL B UPPER THRESHOLD HIGH REGISTER (UTBHR)

R250 - Read/Write
 Register Page: 63
 Reset Value: undefined

7							0
UTB.9	UTB.8	UTB.7	UTB.6	UTB.5	UTB.4	UTB.3	UTB.2

Bits 7:0 = **UTB.[9:2]**: Channel B [9:2] bit Upper Threshold

CHANNEL B UPPER THRESHOLD LOW REGISTER (UTBLR)

R251 - Read/Write
 Register Page: 63
 Reset Value: xx00 0000

7							0
UTB.1	UTB.0	0	0	0	0	0	0

Bits 7:6 = **UTB.[1:0]**: Channel B [1:0] bit Lower Threshold

Bits 5:0 = Reserved, forced by hardware to 0.

REGISTER DESCRIPTION (Cont'd)

CONTROL LOGIC REGISTER 1 (CLR1)

R252 - Read/Write

Register Page: 63

Reset Value: 0000 1111 (0Fh)

7				0			
SC3	SC2	SC1	SC0	CC3	CC2	CC1	CC0

Bits 7:4 = **SC[3:0]**: *Start Conversion Channel*

These four bits define the starting analog input channel (Autoscan Mode). The first channel addressed by SC[3:0] is converted, then the channel number is incremented for the successive conversion, until channel 15 (1111) is converted. When SC3, SC2, SC1 and SC0 are all set, only channel 15 will be converted.

Bits 3:0 = **CC[3:0]**: *Compare Channels*

The programmed value corresponds to the first of the two adjacent channels (A) on which it is possible to define a level window for the converted analog input (see [Table 68](#)).

Note: If a write access to this register occurs, the conversion is re-started from the SC[3:0] channel.

Table 68. Compare Channels definition

CC[3:0]	Channel A	Channel B
0000	15	0
0001	0	1
0010	1	2
0011	2	3

Table 69. Prescaler programming

PR[2:0]	$T_{A/D \text{ clock}} / T_{INTCLK}$	f_{ADC}	T_{Sample}	T_{Conv}	f_{ADC}	T_{Sample}	T_{Conv}	f_{ADC}	T_{Sample}	T_{Conv}
		(MHz)	(μ s)	(μ s)	(MHz)	(μ s)	(μ s)	(MHz)	(μ s)	(μ s)
		@ $T_{INTCLK}=8\text{MHz}$			@ $T_{INTCLK}=20\text{MHz}$			@ $T_{INTCLK}=24\text{MHz}$		
000	2	4.00	2	7	10.00	Not Allowed		12.00	Not Allowed	
001	4	2.00	4	14	5.00	Not Allowed		6.00	Not Allowed	
010	6	1.33	6	21	3.33	2.4	8.4	4.00	2	7
011	8	1.00	8	28	2.50	3.2	11.2	3.00	2.66	9.33
100	10	0.80	Not Allowed		2.00	4	14	2.40	3.33	11.66
101	12	0.66	Not Allowed		1.66	4.8	16.8	2.00	4	14
110	14	0.57	Not Allowed		1.43	5.6	19.6	1.71	4.66	16.33
111	16	0.50	Not Allowed		1.25	6.4	22.4	1.50	5.33	18.66

Table 68. Compare Channels definition

CC[3:0]	Channel A	Channel B
0100	3	4
0101	4	5
0110	5	6
0111	6	7
1000	7	8
1001	8	9
1010	9	10
1011	10	11
1100	11	12
1101	12	13
1110	13	14
1111	14	15

CONTROL LOGIC REGISTER 2 (CLR2)

R253 - Read/Write

Register Page: 63

Reset Value: 1010 0000 (A0h)

7				0			
PR2	PR1	PR0	EXTG	INTG	POW	CONT	ST

Bits 7:5 = **PR[2:0]**: *INTCLK Frequency Prescaler*
 These bits determine the ratio between the ADC clock and the system clock (INTCLK) according to [Table 69](#).

REGISTER DESCRIPTION (Cont'd)

Bit 5 = **ECI**: *End of Conversion Interrupt Enable*.
This bit masks the End of Conversion interrupt request.

0: Mask End of Conversion interrupts
1: Enable End of Conversion interrupts

Bit 4 = **AWDI**: *Analog Watchdog Interrupt Enable*.
This bit masks or enables the Analog Watchdog interrupt request.

0: Mask Analog Watchdog interrupts
1: Enable Analog Watchdog interrupts

Bit 3 = Reserved.

Bits 2:0 = **PL[2:0]**: *ADC Interrupt Priority Level*.
These three bits are used to select the Interrupt priority level for the ADC.

INTERRUPT VECTOR REGISTER (AD_IVR)

R255 - Read/Write

Register Page: 63

Reset Value: xxxx xx10 (x2h)

7							0
V7	V6	V5	V4	V3	V2	W1	0

Bits 7:2 = **V[7:2]**: *ADC Interrupt Vector*.

This vector should be programmed by the user to point to the first memory location in the Interrupt Vector table containing the starting addresses of the ADC interrupt service routines.

Bit 1 = **W1**: *Word Select*.

This bit is set and cleared by hardware, according to the ADC interrupt source.

0: Interrupt source is the Analog Watchdog, pointing to the lower word of the ADC interrupt service block (defined by V[7:2]).

1: Interrupt source is the End of Conversion interrupt, thus pointing to the upper word.

Note: When two requests occur simultaneously, the Analog Watchdog Request has priority over the End of Conversion request, which is held pending.

Bit 0 = Reserved, forced by hardware to 0.

11 ELECTRICAL CHARACTERISTICS

This product contains devices to protect the inputs against damage due to high static voltages, however it is advisable to take normal precautions to avoid application of any voltage higher than the specified maximum rated voltages.

For proper operation it is recommended that V_{IN} and V_O be higher than V_{SS} and lower than V_{DD} . Reliability is enhanced if unused inputs are connected to an appropriate logic voltage level (V_{DD} or V_{SS}).

Power Considerations. The average chip-junction temperature, T_J , in Celsius can be obtained from:

$$T_J = T_A + P_D \times R_{thJA}$$

Where: T_A = Ambient Temperature.

R_{thJA} = Package thermal resistance (junction-to ambient).

$$P_D = P_{INT} + P_{PORT}$$

P_{INT} = $I_{DD} \times V_{DD}$ (chip internal power).

P_{PORT} = Port power dissipation (determined by the user)

ABSOLUTE MAXIMUM RATINGS

Symbol	Parameter	Value	Unit
V_{DD}	Supply Voltage	- 0.3 to 6.5	V
AV_{DD}	ADC Reference Voltage	V_{SS} to $V_{DD} + 0.3$	V
AV_{SS}	ADC Ground	V_{SS}	
V_{IN}	Input Voltage (all pins except pure open drain I/O pins)	- 0.3 to $V_{DD} + 0.3$	V
V_{INOD}	Input Voltage (pure open drain I/O pins)	- 0.3 to 6.5	V
V_{AIN}	Analog Input Voltage (ADC inputs)	-0.3 to $AV_{DD} + 0.3$	V
T_{STG}	Storage Temperature	- 55 to +150	°C
$ I_{IO} $	Load Current	10 ⁽²⁾	mA
$ I_{INJ} $	Pin Injection Current - Digital and Analog Inputs ⁽¹⁾	10 ⁽²⁾	mA
$ I_{TINJ} $	Absolute sum of all Pin Injection Current in the device	100 ⁽²⁾	mA

Notes:

Stresses above those listed as "absolute maximum ratings" may cause permanent damage to the device. This is a stress rating only and functional operation of the device at these conditions is not implied. Exposure to maximum rating conditions for extended periods may affect device reliability. All voltages are referenced to $V_{SS} = 0$ V.

Note 1: Pin injection current occurs when the voltage on any pin exceeds the specified range.

Note 2: Value guaranteed by design.

THERMAL CHARACTERISTICS

Symbol	Package	Value	Unit
RthJA	LQFP64	47	°C/W
	PQFP100	28	
	LQFP100	44	

RECOMMENDED OPERATING CONDITIONS

Symbol	Parameter	Min	Max	Unit	
T_A	Ambient temperature range	6 Suffix Version	-40	85	°C
		B Suffix Version	-40	105	
		C Suffix Version	-40	125	
V_{DD}	Operating Supply Voltage	4.5	5.5	V	
AV_{DD}	ADC Reference Voltage	0	$V_{DD} + 0.2$	V	
f_{INTCLK}	Internal Clock Frequency	0 ⁽¹⁾	24	MHz	
C33	Stabilization capacitor between V_{REG} and V_{SS}	300		nF	

Note: (1) > 1MHz when ADC or JBLPD is used, 2.6MHz when I²C is used

DC ELECTRICAL CHARACTERISTICS

($V_{DD} = 5\text{ V} \pm 10\%$, $T_A = -40^\circ\text{ C}$ to $+125^\circ\text{ C}$, unless otherwise specified)

Symbol	Parameter	Comment	Value			Unit
			Min	Typ (1)	Max	
V_{IH}	Input High Level P0[7:0]-P1[7:0]-P2[7:6]-P2[3:2]- P3.3-P4.2-P4.5-P5.3	TTL	2.0 ⁽²⁾			V
		CMOS	$0.7 \times V_{DD}$ ⁽²⁾			V
	Input High Level Standard Schmitt Trigger P2[5:4]-P2[1:0]-P3[7:4]-P3[2:0]-P4[4:3]- P4[1:0]-P5[7:4]-P5[2:0]-P6[3:0]-P6[7:6]- P7[7:0]-P8[7:0]-P9[7:0]		$0.6 \times V_{DD}$ ⁽²⁾			V
	Input High Level High Hyst. Schmitt Trigger P4[7:6]-P6[5:4]		$0.7 \times V_{DD}$ ⁽²⁾			V
V_{IL}	Input Low Level P0[7:0]-P1[7:0]-P2[7:6]-P2[3:2]-P3.3- P4.2-P4.5-P5.3	TTL			0.8 ⁽²⁾	V
		CMOS			$0.3 \times V_{DD}$ ⁽²⁾	V
	Input Low Level Standard Schmitt Trigger P2[5:4]-P2[1:0]-P3[7:4] P3[2:0]-P4[4:3]- P4[1:0]-P5[7:4]-P5[2:0]-P6[3:0]-P6[7:6]- P7[7:0]-P8[7:0]-P9[7:0]				$0.2 \times V_{DD}$ ⁽²⁾	V
	Input Low Level High Hyst. Schmitt Trigger P4[7:6]-P6[5:4]				$0.25 \times V_{DD}$ ⁽²⁾	V
V_I	Input Voltage Range Pure Open Drain P2[3:2]-P4[7:6]		-0.3		6.0	V
	Input Voltage Range All other pins		-0.3		$V_{DD} + 0.3$	V
V_{HYS}	Input Hysteresis Standard Schmitt Trigger P2[5:4]-P2[1:0]-P3[7:4]-P3[2:0]-P4[4:3]- P4[1:0]-P5[7:4]-P5[2:0]-P6[3:0]-P6[7:6]- P7[7:0]-P8[7:0]-P9[7:0]			250		mV
	Input Hysteresis High Hyst. Schmitt Trigger P4[7:6]-P6[5:4]			1		V
V_{OH}	Output High Level P6[5:4]	Push Pull mode $I_{OH} = -8\text{ mA}$ EMR1.BSZ bit = 1 ⁽³⁾	$V_{DD} - 0.8$			V
	Output High Level P0[7:0]-P2[7:4]-P2[1:0]-P3[7:0]-P4[5:0]- P5[7:0]-P6[3:0]- P6[7:6]-P7[7:0]-P8[7:0]-P9[7:0]-VPWO- AS-DS-RW	Push Pull mode $I_{OH} = -2\text{ mA}$	$V_{DD} - 0.8$			V

ST92F124/F150/F250 - ELECTRICAL CHARACTERISTICS

Symbol	Parameter	Comment	Value			Unit
			Min	Typ (1)	Max	
V _{OL}	Output Low Level P4[7:6]-P6[5:4]	Push Pull or Open Drain mode, I _{OL} =8mA, EMR1.BSZ bit = 1 (3)			0.4	V
	Output Low Level All pins except OSCOUT	Push Pull or Open Drain mode, I _{OL} =2mA			0.4	V
I _{WPU}	Weak Pull-up Current P2[7:4]-P2[1:0]-P3[7:0] P4[7:5]-P4[3:1]-P5.3-P6[7:6]-P6[3:0]- P7[7:0]-P8[7:0]-P9[7:0]	Bidirectional Weak Pull-up mode V _{IN} = 0V	50	100	300	μA
	Weak Pull-up Current P6[5:4]- \overline{AS} - \overline{DS} - \overline{RW}	Bidirectional Weak Pull-up mode V _{IN} = 0V	100	220	450	μA
I _{LKIO}	I/O Pin Input Leakage	Input or Tri-State mode, 0V < V _{IN} < V _{DD}	- 1		1	μA
I _{LKIOD}	I/O Pin Open Drain Input Leakage	Input or Tri-State mode, 0V < V _{IN} < V _{DD}	- 1		1	μA
I _{LKADC}	ADC Conv.Input leakage current on ro- bust pins	V _{IN} <V _{SS} , I _{IN} < 400μA on robust analog pin			6	μA
	ADC Conv.Input leakage current	V _{SS} ≤V _{IN} ≤V _{DD}			1	μA
I _{IO}	Load current	P4[7:6]-P6[5:4] EMR1.BSZ bit = 1 (3)			8 ⁽⁴⁾	mA
		P4[7:6]-P6[5:4] EMR1.BSZ bit = 0 (3)			2 ⁽⁴⁾	
		All other pins except OSCOUT			2 ⁽⁴⁾	
I _{OV}	Overload Current	(5)			5 ⁽⁴⁾	mA
SR _R	Slew Rate Rise	(6)	20		30	ns
SR _F	Slew Rate Fall	(6)	20		30	ns

Note:

- (1) Unless otherwise stated, typical data are based on T_A= 25°C and V_{DD}= 5V. They are only reported for design guide lines not tested in production.
- (2) Value guaranteed by characterisation.
- (3) For a description of the EMR1 Register - BSZ bit refer to the External Memory Interface Chapter.
- (4) Value guaranteed by Design.
- (5) Not tested in production, guaranteed by product characterisation. An overload condition occurs when the input voltage on any pin exceeds the specified voltage range.
- (6) Indicative values extracted from design simulation, 20% to 80% on 50pF load, EMR1.BSZ bit =0.

AC ELECTRICAL CHARACTERISTICS

($V_{DD} = 5\text{ V} \pm 10\%$, $T_A = -40^\circ\text{C}$ to $+125^\circ\text{C}$ for Max values and 25°C for Typ values, unless otherwise specified)

Symbol	Parameter	Conditions	INTCLK	Typ ⁽¹⁾	Max	Unit
I_{DDRUN}	Run Mode Current	CPU running with code execution from RAM memory, all peripherals in reset state, clock input (OSCIN) driven by external square wave. f_{INTCLK} in [MHz].	24 MHz	45	60	mA
			any frequency	$2.5 + 1.8 \times f_{INTCLK}/\text{MHz}$		mA
ΔI_{DD1}	FLASH/E ³ ™ Supply Current (Read) ⁽²⁾		-	2		mA
ΔI_{DD2}	FLASH/E ³ ™ Supply Current (Write/Erase) ⁽²⁾		-	12		mA
	Typical application Run Mode Current	CPU running with code execution from FLASH memory, all peripherals running in a typical configuration, clock input (OSCIN) driven by a 4-MHz crystal = $I_{DDRUN} + \Delta I_{DD1} + I_{DD}$ Peripherals (Timers, CAN, etc)	24 MHz	50		mA
I_{DDWFI}	WFI Mode Current	f_{INTCLK} in [MHz].	24 MHz	14	22	mA
			any frequency		$0.9 \times f_{INTCLK}/\text{MHz}$ ⁽³⁾	mA
ΔI_{DD3}	FLASH/E ³ ™ Supply Current (Stand-by) ⁽⁴⁾		-	20		μA
I_{DDLPR}	Main Voltage Regulator Power Consumption		-	300		μA
I_{DDOSC}	Crystal Oscillator Power Consumption			200		μA
I_{DDLWFI}	Low Power WFI Mode Current	FLASH/E ³ ™ in Stand-by Mode, Main Voltage Regulator ON, $I_{DDLPR} + I_{DDOSC} + I_{DD}$ (Standard Timer in real time clock mode)	4MHz / 32	550	1000	μA
I_{DDRTC}	RTC Mode Current	FLASH/E ³ ™ in Power-Down Mode, Main Voltage Regulator OFF, Standard Timer in Real Time Clock mode	4MHz / 32	250		μA
I_{DDHALT}	HALT Mode Current ⁽³⁾		-	5	25	μA
I_{DDSTOP}	STOP Mode Current ⁽³⁾	All I/O ports are configured in output push-pull mode with no DC load		see Figure 159 ⁽³⁾		μA
I_{DDTR}	Input Transient I_{DD} Current ⁽⁵⁾		-	300		μA

Note:

All I/O Ports are configured in bidirectional weak pull-up mode with no DC load, unless otherwise specified, external clock is driven by a square wave.

(1) Unless otherwise stated, typical data are based on $V_{DD} = 5\text{V}$. They are only reported for design guide lines not tested in production.

(2) Current consumption to be added to I_{DDRUN} when the FLASH memory is accessed.

(3) Value guaranteed by product characterization, not tested in production.

(4) Current consumption to be added to I_{DDLWFI} when the FLASH memory is in stand-by mode.

(5) The I/Os draw a transient current from V_{DD} when an input takes a voltage level in between V_{SS} and V_{DD} . This current is 0 for $V_{IN} < 0.3V$ or $V_{IN} > V_{DD} - 0.3V$, it typically reaches its maximum value when V_{IN} is approximatively at $V_{DD}/2$.

Figure 159. Stop Mode Current

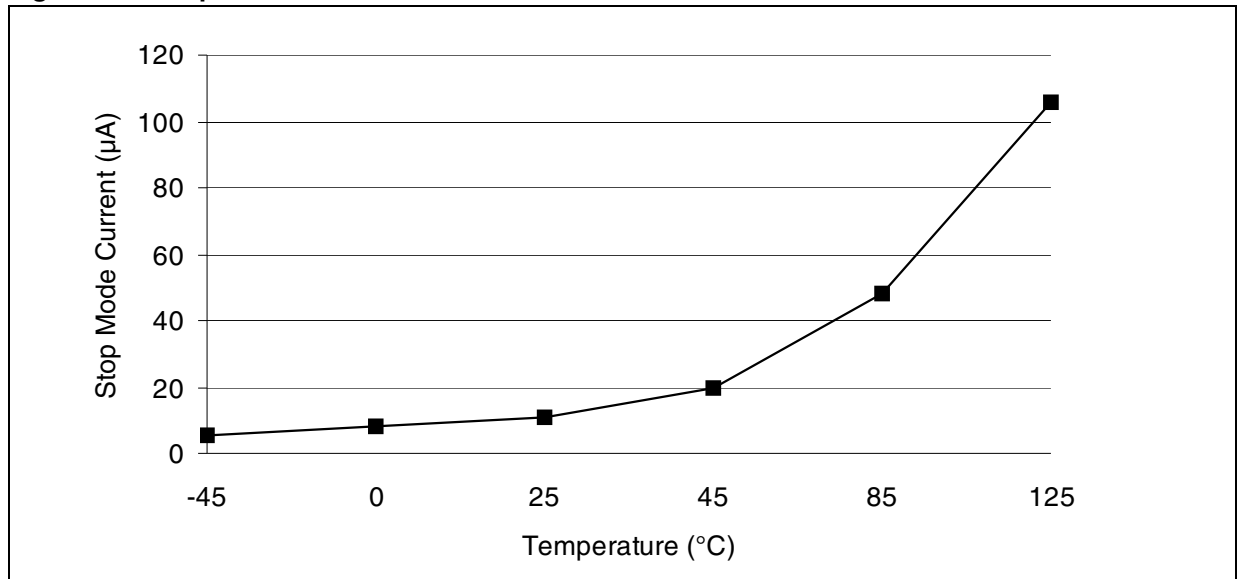

FLASH / E³™ SPECIFICATIONS

(V_{DD} = 5V ± 10%, T_A = -40°C to +125°C, unless otherwise specified)

Parameter		Min	Typ	Max	Unit
MAIN FLASH	Byte Program		10	250	μs
	128 kbytes Flash Program		1.3	4	s
	64 kbytes Flash Sector Erase		1.5	30	s
	128 kbytes Flash Chip Erase		3	30	s
	Erase Suspend Latency			15	μs
	Recovery from Power-Down			10	μs
E ³ ™	16 bytes Page Update (1k E ³ ™) -40°C +105°C		30	200 ⁽¹⁾	ms
RELIABILITY	Flash Endurance 25°C	10000			cycles
	Flash Endurance	3000			
	E ³ ™ Endurance	800000 ⁽²⁾			page updates
	Data Retention	15			years

Note:

- (1) The maximum value depends on the number of E3 cycles/sector as shown in Figure 160. This maximum value corresponds to the worst case E³™ page update, 1 of 4 consecutive write operations at the same E³™ address (refer to AN1152). In any case, the page update operation starts with the write operation of the data (160 μs max). Then, one of the 4 erase operations of the unused sector may be performed, leading to the worst case.
- (2) Relational calculation between E³™ page updates and single byte cycling is provided in a dedicated STMicroelectronics Application Note (ref. AN1152).

Figure 160. Evolution of Worst Case E3 Page Update Time

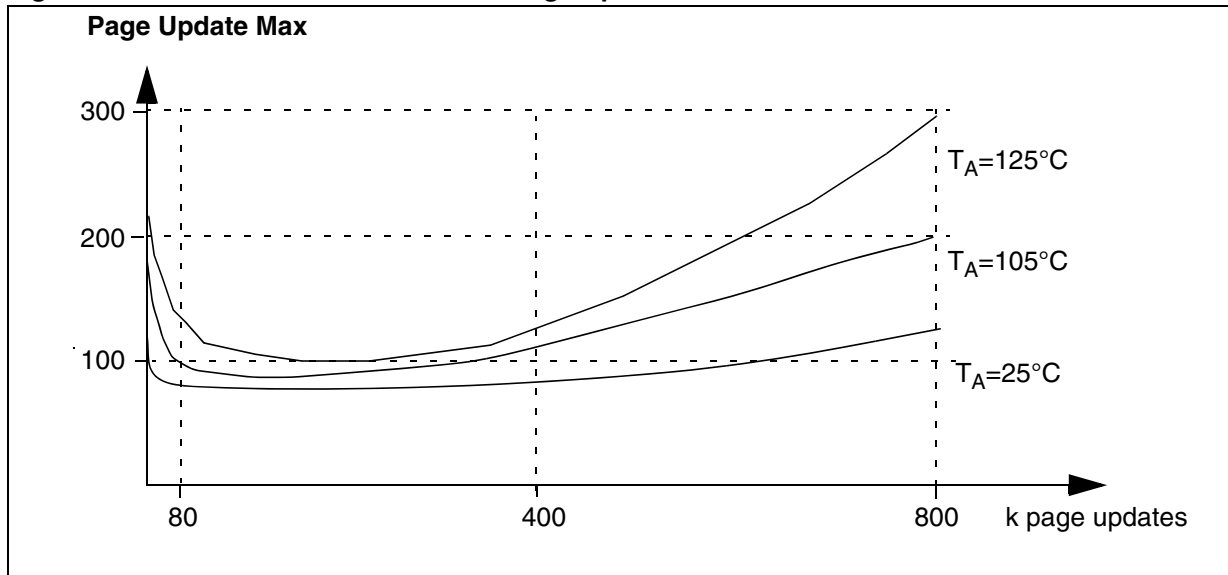

EMC CHARACTERISTICS

Susceptibility tests are performed on a sample basis during product characterization.

Functional EMS (Electro Magnetic Susceptibility)

Based on a simple application running on the product, the product is stressed by two electro magnetic events until a failure occurs.

- **ESD:** Electro-Static Discharge (positive and negative) is applied on all pins of the device until a functional disturbance occurs. This test conforms with the IEC 1000-4-2 standard.
- **FTB:** A Burst of Fast Transient voltage (positive and negative) is applied to V_{DD} and V_{SS} through a 100pF capacitor, until a functional disturbance occurs. This test conforms with the IEC 1000-4-4 standard.

A device reset allows normal operations to be resumed.

Designing hardened software to avoid noise problems

EMC characterization and optimization are performed at component level with a typical application environment and simplified MCU software. It should be noted that good EMC performance is

highly dependent on the user application and the software in particular.

Therefore it is recommended that the user applies EMC software optimization and prequalification tests in relation with the EMC level requested for his application.

Software recommendations:

The software flowchart must include the management of runaway conditions such as:

- Corrupted program counter
- Unexpected reset
- Critical Data corruption (control registers...)

Prequalification trials:

Most of the common failures (unexpected reset and program counter corruption) can be reproduced by manually forcing a low state on the RESET pin or the Oscillator pins for 1 second.

To complete these trials, ESD stress can be applied directly on the device, over the range of specification values. When unexpected behaviour is detected, the software can be improved to prevent unrecoverable errors occurring (see application note AN1015).

Symbol	Parameter	Conditions	Level	Unit
V_{FESD}	Voltage limits to be applied on any I/O pin to induce a functional disturbance	$V_{DD}=5V$, $T_A=+25^\circ C$, $f_{OSC}=4MHz$ conforms to IEC 1000-4-2	>1.5	kV
V_{FFTB}	Fast transient voltage burst limits to be applied through 100pF on V_{DD} and V_{DD} pins to induce a functional disturbance	$V_{DD}=5V$, $T_A=+25^\circ C$, $f_{OSC}=8MHz$ conforms to IEC 1000-4-4	>1.5	kV

Electro Magnetic Interference (EMI)

Based on a simple application running on the product, the product is monitored in terms of emission. This emission test is in line with the norm SAE J 1752/3 which specifies the board and the loading of each pin.

Symbol	Parameter	Conditions	Monitored Frequency Band	Max vs. $[f_{OSC}/f_{CPU}]$	Unit
				4/10MHz	
S_{EMI}	Peak level	$V_{DD}=5V$, $T_A=+25^\circ C$, PQFP100 14x20 package conforming to SAE J 1752/3	0.1MHz to 30MHz	13	dB μ V
			30MHz to 130MHz	25	
			130MHz to 1GHz	24	
			SAE EMI Level	3.5	-

Notes:

1. Data based on characterization results, not tested in production.

EMC CHARACTERISTICS (Cont'd)

Absolute Maximum Ratings (Electrical Sensitivity)

Based on three different tests (ESD, LU and DLU) using specific measurement methods, the product is stressed in order to determine its performance in terms of electrical sensitivity. For more details, refer to the application note AN1181.

Electro-Static Discharge (ESD)

Electro-Static Discharges (a positive then a negative pulse separated by 1 second) are applied to the pins of each sample according to each pin combination. The sample size depends on the number of supply pins in the device (3 parts*(n+1) supply pin). Two models can be simulated: Human Body Model and Machine Model. This test conforms to the JESD22-A114A/A115A standard.

Absolute Maximum Ratings

Symbol	Ratings	Conditions	Maximum value ¹⁾	Unit
V _{ESD(HBM)}	Electro-static discharge voltage (Human Body Model)	T _A =+25°C	2000	V
V _{ESD(MM)}	Electro-static discharge voltage (Machine Model)	T _A =+25°C	200	

Notes:

1. Data based on characterization results, not tested in production.

Static and Dynamic Latch-Up

- **LU:** 3 complementary static tests are required on 10 parts to assess the latch-up performance. A supply overvoltage (applied to each power supply pin) and a current injection (applied to each input, output and configurable I/O pin) are performed on each sample. This test conforms to the EIA/JESD 78 IC latch-up standard. For more details, refer to the application note AN1181.
- **DLU:** Electro-Static Discharges (one positive then one negative test) are applied to each pin of 3 samples when the micro is running to assess the latch-up performance in dynamic mode. Power supplies are set to the typical values, the oscillator is connected as near as possible to the pins of the micro and the component is put in reset mode. This test conforms to the IEC1000-4-2 and SAEJ1752/3 standards. For more details, refer to the application note AN1181.

Electrical Sensitivities

Symbol	Parameter	Conditions	Class ¹⁾
LU	Static latch-up class	T _A =+25°C	A
		T _A =+85°C	A
		T _A =+125°C	A
DLU	Dynamic latch-up class	V _{DD} =5.5V, f _{OSC} =4MHz, T _A =+25°C	A

Notes:

1. Class description: A Class is an STMicroelectronics internal specification. All its limits are higher than the JEDEC specifications, that means when a device belongs to Class A it exceeds the JEDEC standard. B Class strictly covers all the JEDEC criteria (international standard).

EXTERNAL INTERRUPT TIMING TABLE

($V_{DD} = 5V \pm 10\%$, $T_A = -40^\circ\text{C}$ to $+125^\circ\text{C}$, $C_{Load} = 50\text{pF}$, $f_{INTCLK} = 24\text{MHz}$, unless otherwise specified)

N°	Symbol	Parameter	Value		Unit
			Formula	Min	
1	TwINTLR	Low Level Minimum Pulse Width in Rising Edge Mode	$\geq T_{ck}+10$	50	ns
2	TwINTHR	High Level Minimum Pulse Width in Rising Edge Mode	$\geq T_{ck}+10$	50	ns
3	TwINTHF	High Level Minimum Pulse Width in Falling Edge Mode	$\geq T_{ck}+10$	50	ns
4	TwINTLF	Low Level Minimum Pulse Width in Falling Edge Mode	$\geq T_{ck}+10$	50	ns

Note:
The value in the left hand column shows the formula used to calculate the timing minimum or maximum from the oscillator clock period. The value in the right hand two columns shows the timing minimum and maximum for an internal clock at 24MHz (INTCLK).

Measurement points are V_{IH} for positive pulses and V_{IL} for negative pulses.

Legend:

Tck = INTCLK period = Crystal Oscillator Clock period when CLOCK1 is not divided by 2;
 2 x Crystal Oscillator Clock period when CLOCK1 is divided by 2;
 Crystal Oscillator Clock period x PLL factor when the PLL is enabled.

EXTERNAL INTERRUPT TIMING

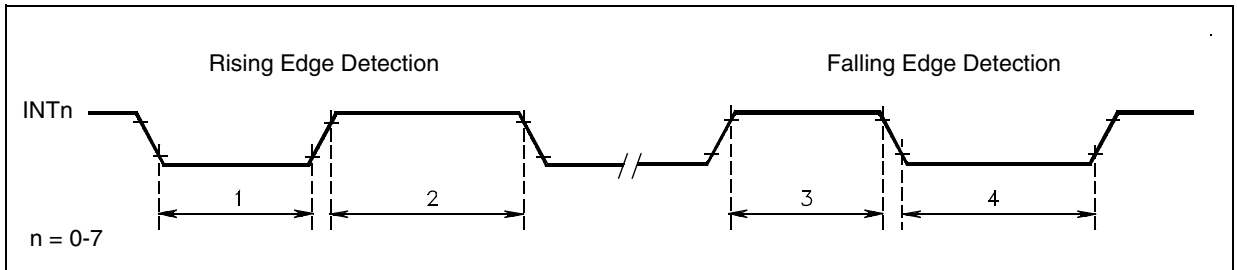

WAKE-UP MANAGEMENT TIMING TABLE

($V_{DD} = 5V \pm 10\%$, $T_A = -40^\circ\text{C}$ to $+125^\circ\text{C}$, $C_{Load} = 50\text{pF}$, $f_{INTCLK} = 24\text{MHz}$, unless otherwise specified)

N°	Symbol	Parameter	Value		Unit
			Formula	Min	
1	TwWKPLR	Low Level Minimum Pulse Width in Rising Edge Mode	$\geq T_{ck}+10$	50	ns
2	TwWKPHR	High Level Minimum Pulse Width in Rising Edge Mode	$\geq T_{ck}+10$	50	ns
3	TwWKPHF	High Level Minimum Pulse Width in Falling Edge Mode	$\geq T_{ck}+10$	50	ns
4	TwWKPLF	Low Level Minimum Pulse Width in Falling Edge Mode	$\geq T_{ck}+10$	50	ns

Note: The value in the left hand column shows the formula used to calculate the timing minimum or maximum from the oscillator clock period. The value in the right hand two columns show the timing minimum and maximum for an internal clock at 24MHz (INTCLK).

The given data are related to Wake-up Management Unit used in External Interrupt mode.

Measurement points are V_{IH} for positive pulses and V_{IL} for negative pulses.

Legend:

Tck = INTCLK period = Crystal Oscillator Clock period when CLOCK1 is not divided by 2;
 2 x Crystal Oscillator Clock period when CLOCK1 is divided by 2;
 Crystal Oscillator Clock period x PLL factor when the PLL is enabled.

WAKE-UP MANAGEMENT TIMING

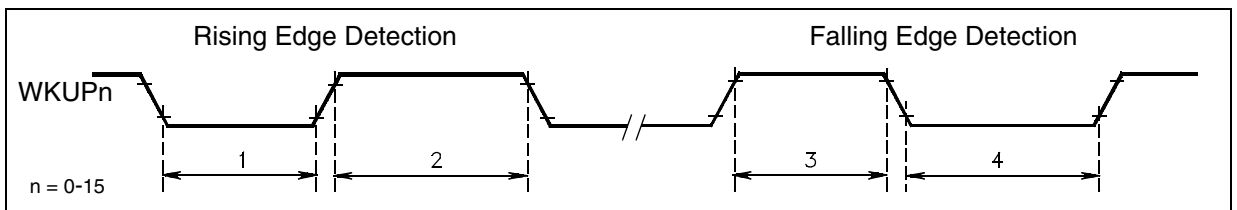

RCCU CHARACTERISTICS

($V_{DD} = 5V \pm 10\%$, $T_A = -40^\circ C$ to $+125^\circ C$, $C_{Load} = 50pF$, $f_{INTCLK} = 24MHz$, unless otherwise specified)

Symbol	Parameter	Comment	Value			Unit
			Min	Typ ⁽¹⁾	Max	
V_{IHRS}	\overline{RESET} Input High Level	Input Threshold	$0.75 \times V_{DD}$			V
V_{ILRS}	\overline{RESET} Input Low Level	Input Threshold			$0.25 \times V_{DD}$	V
V_{IRS}	Input Voltage Range		- 0.3		$V_{DD} + 0.3$	V
V_{HYRS}	\overline{RESET} Input Hysteresis			1 ⁽²⁾		V
I_{LKRS}	\overline{RESET} Pin Input Leakage	$0V < V_{IN} < V_{DD}$	- 1		1	μA

Note:

(1) Unless otherwise stated, typical data are based on $T_A = 25^\circ C$ and $V_{DD} = 5V$. They are only reported for design guide lines not tested in production.

(2) Value guaranteed by design.

RCCU TIMING TABLE

($V_{DD} = 5V \pm 10\%$, $T_A = -40^\circ C$ to $+125^\circ C$, $f_{INTCLK} = 24 MHz$, unless otherwise specified)

Symbol	Parameter	Comment	Value			Unit
			Min	Typ ⁽¹⁾	Max	
t_{FRS}	\overline{RESET} Input Filtered Pulse ⁽²⁾				50	ns
t_{NFR}	\overline{RESET} Input Non Filtered Pulse ⁽²⁾		20			μs
t_{RSPH} ⁽³⁾	\overline{RESET} Phase duration			20400		T_{osc}
t_{STR}	STOP Restart duration	DIV2 = 0 DIV2 = 1		10200 20400		T_{osc}

Note:

(1) Unless otherwise stated, typical data are based on $T_A = 25^\circ C$ and $V_{DD} = 5V$. They are only reported for design guide lines not tested in production.

(2) To be valid, a \overline{RESET} pulse must exceed t_{NFR} . All reset glitches with a duration shorter than t_{FRS} will be filtered

(3) Depending on the delay between rising edge of \overline{RESET} pin and the first rising edge of $CLOCK1$, the value can differ from the typical value for +/- 1 $CLOCK1$ cycle.

Legend: T_{osc} = Crystal Oscillator Clock ($CLOCK1$) period.

BOOTROM TIMING TABLE

Symbol	Parameter	Conditions	Typ Value ⁽¹⁾	Unit
t_{BRE}	BOOTROM Execution Duration (see Figure 65 on page 137) ⁽²⁾	$f_{OSC} = 4MHz$	33	ms

Note:

(1) Unless otherwise stated, typical data are based on $T_A = 25^\circ C$ and $V_{DD} = 5V$. They are only reported for design guide lines not tested in production

(2) Refer to AN1528 for more details on BOOTROM code.

PLL CHARACTERISTICS

($V_{DD} = 5\text{ V} \pm 10\%$, $T_A = -40^\circ\text{ C to } +125^\circ\text{ C}$, $f_{INTCLK} = 24\text{ MHz}$, unless otherwise specified)

Symbol	Parameter	Value			Unit
		Min	Typ ⁽¹⁾	Max	
F_{XTL}	Crystal Reference Frequency	3		5	MHz
F_{VCO}	VCO Operating Frequency	6		24	MHz
T_{PLK}	Lock-in Time		350 ⁽²⁾	1000 ⁽²⁾	T_{osc}
	PLL Jitter	0		1200 ⁽²⁾	ps
	PLL Jitter Impact on applicative 500kHz signal (CAN, SCI, TIMERS)			0.2 ⁽²⁾	%
$F_{PLLFREE}$	PLL free running mode Frequency	10 ⁽²⁾	50	250 ⁽²⁾	kHz

Note:

(1) Unless otherwise stated, typical data are based on $T_A = 25^\circ\text{C}$ and $V_{DD} = 5\text{V}$. They are only reported for design guide lines not tested in production.

(2) Value guaranteed by design.

Legend: T_{osc} = Crystal Oscillator Clock (CLOCK1) period.

OSCILLATOR CHARACTERISTICS

($V_{DD} = 5V \pm 10\%$, $T_A = -40^\circ\text{C}$ to $+125^\circ\text{C}$, $C_{Load} = 50\text{pF}$, $f_{INTCLK} = 24\text{MHz}$, unless otherwise specified)

Symbol	Parameter	Comment	Value			Unit
			Min	Typ ⁽¹⁾	Max	
f_{OSC}	Crystal Frequency	Fundamental mode crystal or external clock applied to OSCOUT	3		5	MHz
g_m	Oscillator Transconductance		1.2 ⁽²⁾	1.5 ⁽²⁾		mA/V
V_{IHCK}	Clock Input High Level	External Clock	2 ⁽²⁾		$V_{DD} + 0.3$	V
V_{ILCK}	Clock Input Low Level	External Clock	-0.3		0.4 ⁽²⁾	V
T_{STUP}	Oscillator Start-up Time				5 ⁽²⁾	ms
I_{LOAD}				100		μA
R_{POL}			90	128	180	$\text{k}\Omega$
V_{OSC}	Oscillation Level			600 ⁽²⁾		mV

Note:
 (1) Unless otherwise stated, typical data are based on $T_A = 25^\circ\text{C}$ and $V_{DD} = 5\text{V}$. They are only reported for design guide lines not tested in production.
 (2) Value guaranteed by design.

EXTERNAL BUS TIMING TABLE (MC=1)

($V_{DD} = 5V \pm 10\%$, $T_A = -40^\circ C$ to $+125^\circ C$, $C_{Load} = 0$ to $50pF$)

N°	Symbol	Parameter	Value (see note)			Unit
			Formula	Min	Max	
1	TsA (ALE)	Address Set-up Time before ALE ↓	$Tck * Wa + TckH - 48$	160		ns
2	ThALE (A)	Address Hold Time after ALE ↓	$TckL - 31$	10		ns
3	TwALE	ALE High Pulse Width	$Tck * Wa + TckH - 58$	150		ns
4	TdAz (OEN)	Address Float (P0) to \overline{OEN} ↓	0	0		ns
5	TdOEN(Az)	P0 driven after \overline{OEN} ↑	$TckL - 13$	29		ns
6	TwoEN	\overline{OEN} Low Pulse Width	$Tck * Wd + TckH - 36$	172		ns
7	TwWEN	\overline{WEN} Low Pulse Width	$Tck * Wd + TckH - 36$	172		ns
8	TdOEN (DR)	\overline{OEN} ↓ to Data Valid Delay	$Tck * Wd + TckH - 44$		164	ns
9	ThDR (OEN)	Data hold time after \overline{OEN} ↑	0	0		ns
10	ThOEN(A)	Address (A21:A8) hold time after \overline{OEN} ↑	0	0		ns
11	ThWEN(A)	Address (A21:A8) hold time after \overline{WEN} ↑	0	0		ns
12	TvA(OEN)	Address (A21:A0) valid to \overline{OEN} ↑	$Tck (Wd + Wa + 1.5) - 76$	382		ns
13	TvA(WEN)	Address (A21:A0) valid to \overline{WEN} ↑	$Tck (Wd + Wa + 1.5) - 44$	414		ns
14	TsD (WEN)	Data Set-up time before \overline{WEN} ↑	$Tck * Wd + TckH - 158$	50		ns
15	ThWEN(DW)	Data Hold Time after \overline{WEN} ↑	$TckL - 37$	5		ns
16	TdALE (WEN)	ALE ↑ to \overline{WEN} ↑ Delay	$Tck (Wd + Wa + 1.5) - 54$	404		ns
17	TdALE (OEN)	ALE ↑ to \overline{OEN} ↑ Delay	$Tck (Wd + Wa + 1.5) - 50$	408		ns

Notes:

The expressions in the "Formula" column show how to calculate the typical parameter value depending on the CPU clock period and the number of inserted wait cycles. The values in the Min column give the parameter values for a CPU clock at 12MHz and two wait states for T1 and T2.

For certain versions of the ST92F150, the external bus has high-drive capabilities.

Legend:

$Tck = INTCLK$ period = OSCIN period when OSCIN is not divided by 2;

= 2*OSCIN period when OSCIN is divided by 2;

= OSCIN period / PLL factor when the PLL is enabled

$TckH = INTCLK$ high pulse width (normally = $Tck/2$, except when $INTCLK = OSCIN$, in which case it is OSCIN high pulse width)

$TckL = INTCLK$ low pulse width (normally = $Tck/2$, except when $INTCLK = OSCIN$, in which case it is OSCIN low pulse width)

P = clock prescaling value (=PRS; division factor = 1+P)

Wa = wait cycles on ALE; = max (P, programmed wait cycles in EMR2, requested wait cycles with \overline{WAIT})

Wd = wait cycles on \overline{OEN} and \overline{WEN} ; = max (P, programmed wait cycles in WCR, requested wait cycles with \overline{WAIT})

EXTERNAL BUS TIMING

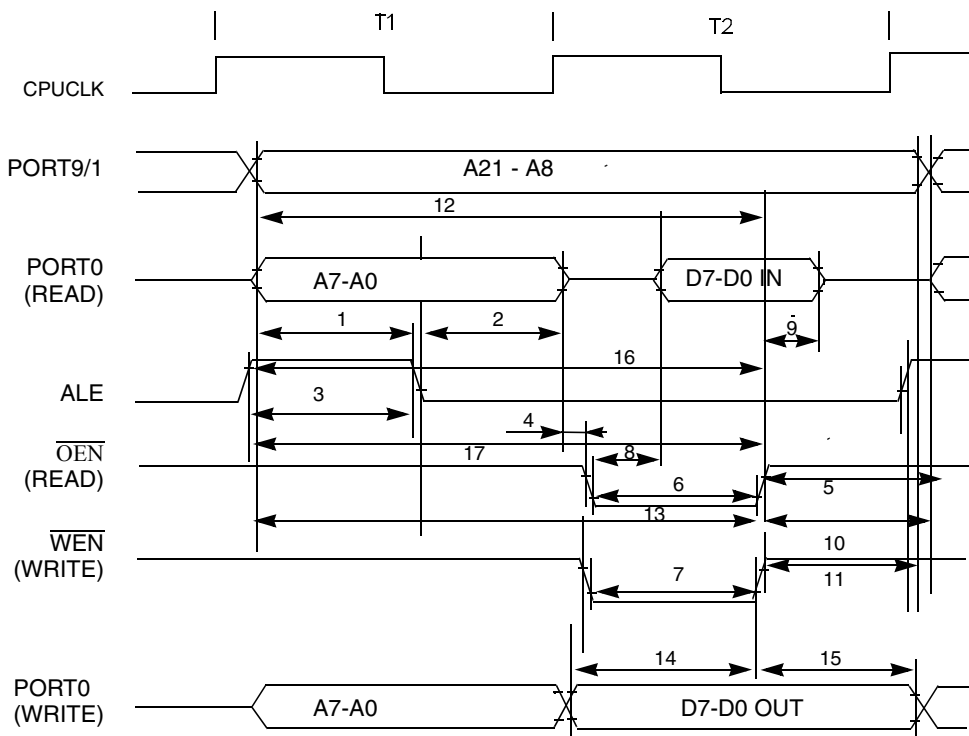

Note : OEN stays high for the whole write cycle and WEN stays high for the whole read cycle.

WATCHDOG TIMING TABLE

($V_{DD} = 5V \pm 10\%$, $T_A = -40^\circ C$ to $+125^\circ C$, $C_{Load} = 50pF$, $f_{INTCLK} = 24MHz$, Push-pull output configuration, unless otherwise specified)

N°	Symbol	Parameter	Value			Unit
			Formula	Min	Max	
1	TwWDOL	WDOOUT Low Pulse Width	$4 \times (Psc+1) \times (Cnt+1) \times Tck$	167	2.8	ns s
			$(Psc+1) \times (Cnt+1) \times T_{WDIN}$	333		ns
2	TwWDOH	WDOOUT High Pulse Width	$4 \times (Psc+1) \times (Cnt+1) \times Tck$	167	2.8	ns s
			$(Psc+1) \times (Cnt+1) \times T_{WDIN}$	333		ns
3	TwWDIL	WDIN High Pulse Width	$\geq 4 \times Tck$	167		ns
4	TwWDIH	WDIN Low Pulse Width	$\geq 4 \times Tck$	167		ns

Note: The value in the left hand column shows the formula used to calculate the timing minimum or maximum from the oscillator clock period, watchdog prescaler and counter programmed values.

The value in the right hand two columns show the timing minimum and maximum for an internal clock (INTCLK) at 24MHz, with minimum and maximum prescaler value and minimum and maximum counter value.

Measurement points are V_{OH} or V_{IH} for positive pulses and V_{OL} or V_{IL} for negative pulses.

Legend:

Tck = INTCLK period = Crystal Oscillator Clock period when CLOCK1 is not divided by 2;

2 x Crystal Oscillator Clock period when CLOCK1 is divided by 2;

Crystal Oscillator Clock period x PLL factor when the PLL is enabled.

Psc = Watchdog Prescaler Register content (WDTPR): from 0 to 255

Cnt = Watchdog Counter Registers content (WDTRH,WDTRL): from 0 to 65535

T_{WDIN} = Watchdog Input signal period (WDIN), $T_{WDIN} \geq 8 \times Tck$

WATCHDOG TIMING

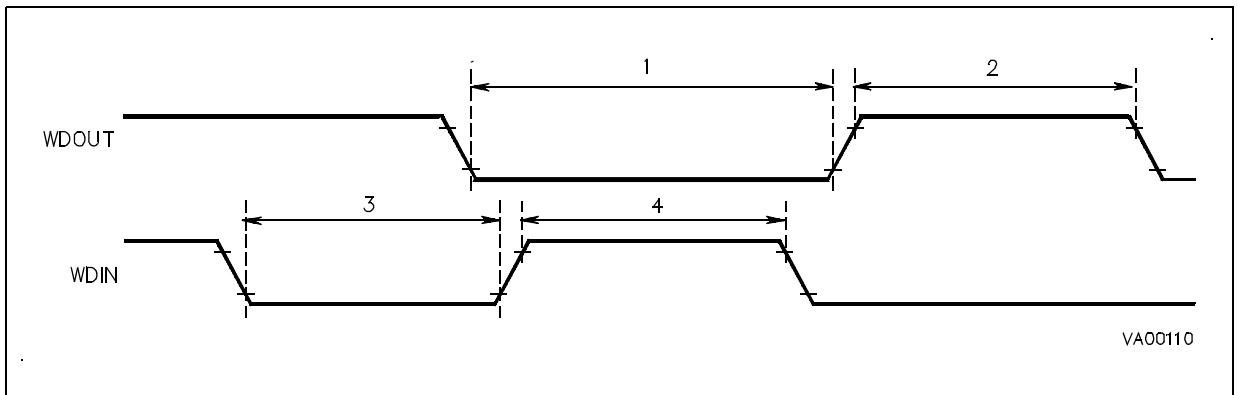

STANDARD TIMER TIMING TABLE

($V_{DD} = 5V \pm 10\%$, $T_A = -40^{\circ}C$ to $+125^{\circ}C$, $C_{Load} = 50pF$, $f_{INTCLK} = 24MHz$, Push-pull output configuration, unless otherwise specified)

N°	Symbol	Parameter	Value			Unit
			Formula	Min	Max	
1	TwSTOL	STOUT Low Pulse Width	$4 \times (Psc+1) \times (Cnt+1) \times Tck$	167	2.8	ns s
			$(Psc+1) \times (Cnt+1) \times T_{STIN}$	(1)	(1)	ns
2	TwSTOH	STOUT High Pulse Width	$4 \times (Psc+1) \times (Cnt+1) \times Tck$	167	2.8	ns s
			$(Psc+1) \times (Cnt+1) \times T_{STIN}$	(1)	(1)	ns
3	TwSTIL	STIN High Pulse Width	$\geq 4 \times Tck$	(1)	(1)	ns
4	TwSTIH	STIN Low Pulse Width	$\geq 4 \times Tck$	(1)	(1)	ns

Note: The value in the left hand column shows the formula used to calculate the timing minimum or maximum from the oscillator clock period, standard timer prescaler and counter programmed values.

The value in the right hand two columns show the timing minimum and maximum for an internal clock (INTCLK) at 24MHz, with minimum and maximum prescaler value and minimum and maximum counter value.

Measurement points are V_{OH} or V_{IH} for positive pulses and V_{OL} or V_{IL} for negative pulses.

(1) On this product STIN is not available as Alternate Function but it is internally connected to a precise clock source directly derived from the crystal oscillator. Refer to RCCU chapter for details about clock distribution.

Legend:

$Tck = INTCLK$ period = Crystal Oscillator Clock period when CLOCK1 is not divided by 2;
 2 x Crystal Oscillator Clock period when CLOCK1 is divided by 2;
 Crystal Oscillator Clock period x PLL factor when the PLL is enabled.

Psc = Standard Timer Prescaler Register content (STP): from 0 to 255

Cnt = Standard Timer Counter Registers content (STH,STL): from 0 to 65535

$T_{STIN} =$ Standard Timer Input signal period (STIN) , $T_{STIN} \geq 8 \times Tck$

STANDARD TIMER TIMING

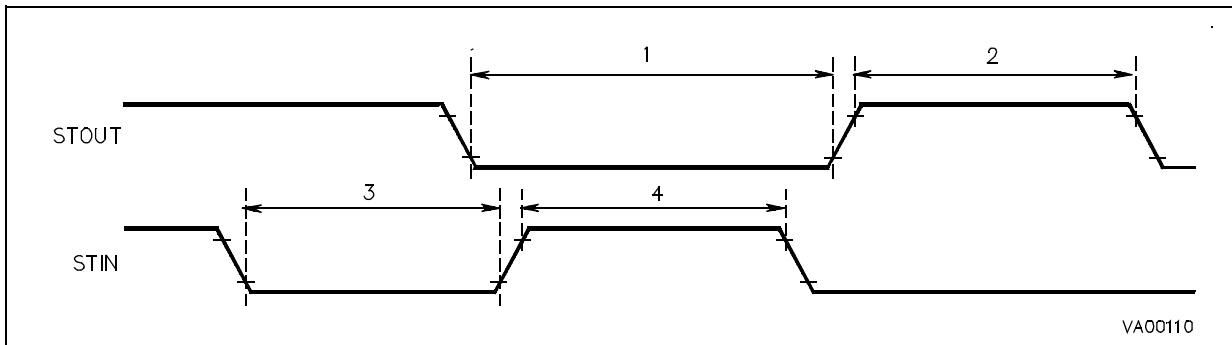

EXTENDED FUNCTION TIMER EXTERNAL TIMING TABLE

($V_{DD} = 5V \pm 10\%$, $T_A = -40^\circ C$ to $+125^\circ C$, $C_{Load} = 50pF$, $f_{INTCLK} = 24MHz$, unless otherwise specified)

N°	Symbol	Parameter	Value		Unit
			Formula	Min	
1	TW_{PEWL}	External Clock low pulse width (EXTCLK)	$\geq 2 \times Tck + 10$	52	ns
2	TW_{PEWH}	External Clock high pulse width (EXTCLK)	$\geq 2 \times Tck + 10$	52	ns
3	TW_{PIWL}	Input Capture low pulse width (ICAPx)	$\geq 2 \times Tck + 10$	52	ns
4	TW_{PIWH}	Input Capture high pulse width (ICAPx)	$\geq 2 \times Tck + 10$	52	ns
5	TW_{ECKD}	Distance between two active edges on EXTCLK	$\geq 4 \times Tck + 10$	177	ns
6	TW_{EICD}	Distance between two active edges on ICAPx	$\geq 2 \times Tck \times Prsc + 10$	177	ns

Note: The value in the left hand column shows the formula used to calculate the timing minimum or maximum from the oscillator clock period, standard timer prescaler and counter programmed values. The value in the right hand two columns show the timing minimum and maximum for an internal clock (INTCLK) at 24MHz, and minimum prescaler factor (=2).

Measurement points are V_{IH} for positive pulses and V_{IL} for negative pulses.

Legend:

$Tck = INTCLK$ period = Crystal Oscillator Clock period when CLOCK1 is not divided by 2;

2 x Crystal Oscillator Clock period when CLOCK1 is divided by 2;

Crystal Oscillator Clock period x PLL factor when the PLL is enabled.

$Prsc =$ Prescaler factor defined by Extended Function Timer Clock Control bits (CC1,CC0) on control register CR2 (values: 2,4,8).

EXTENDED FUNCTION TIMER EXTERNAL TIMING

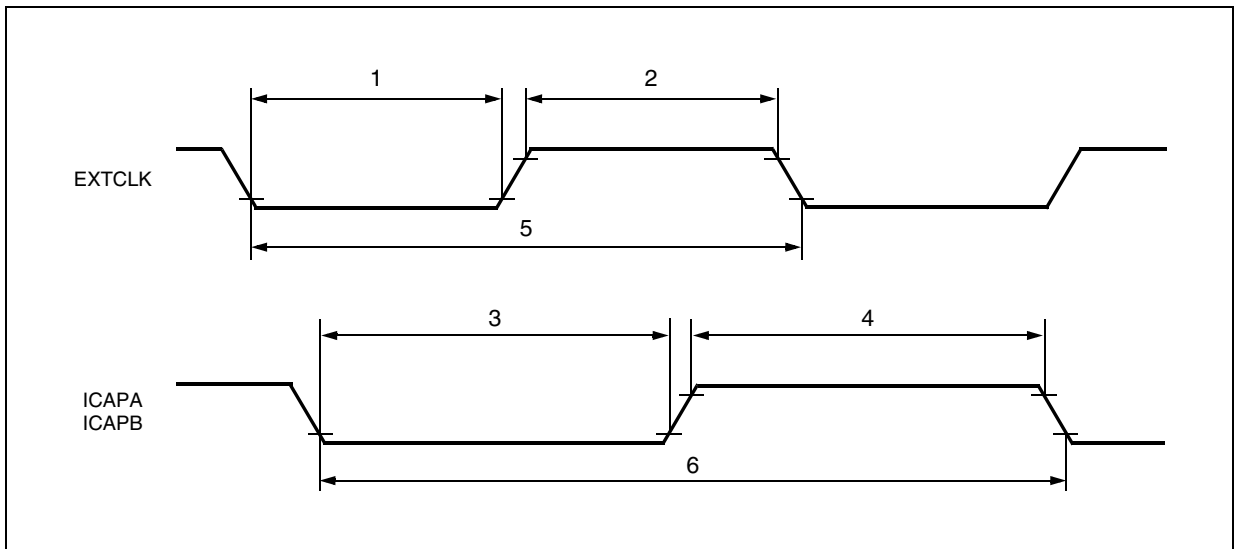

MULTIFUNCTION TIMER EXTERNAL TIMING TABLE

($V_{DD} = 5V \pm 10\%$, $T_A = -40^\circ C$ to $+125^\circ C$, $C_{Load} = 50pF$, $f_{INTCLK} = 24MHz$, unless otherwise specified)

N°	Symbol	Parameter	Value			Unit	Note
			Formula	Min	Max		
1	TW_{CTW}	External clock/trigger pulse width	$n \times Tck$	$n \times 42$	-	ns	(1)
2	TW_{CTD}	External clock/trigger pulse distance	$n \times Tck$	$n \times 42$	-	ns	(1)
3	TW_{AED}	Distance between two active edges	$3 \times Tck$	125	-	ns	
4	TW_{GW}	Gate pulse width	$6 \times Tck$	250	-	ns	
5	TW_{LBA}	Distance between TINB pulse edge and the following TINA pulse edge	Tck	42	-	ns	(2)
6	TW_{LAB}	Distance between TINA pulse edge and the following TINB pulse edge		0	-	ns	(2)
7	TW_{AD}	Distance between two TxINA pulses		0	-	ns	(2)
8	TW_{OWD}	Minimum output pulse width/distance	$3 \times Tck$	125	-	ns	

Note: The value in the left hand column shows the formula used to calculate the timing minimum or maximum from the oscillator clock period, standard timer prescaler and counter programmed values.

The value in the right hand two columns show the timing minimum and maximum for an internal clock (INTCLK) at 24MHz.

(1) $n = 1$ if the input is rising OR falling edge sensitive

$n = 3$ if the input is rising AND falling edge sensitive

(2) In Autodiscrimination mode

Legend:

$Tck = INTCLK$ period = Crystal Oscillator Clock period when CLOCK1 is not divided by 2;

2 x Crystal Oscillator Clock period when CLOCK1 is divided by 2;

Crystal Oscillator Clock period x PLL factor when the PLL is enabled.

MULTIFUNCTION TIMER EXTERNAL TIMING

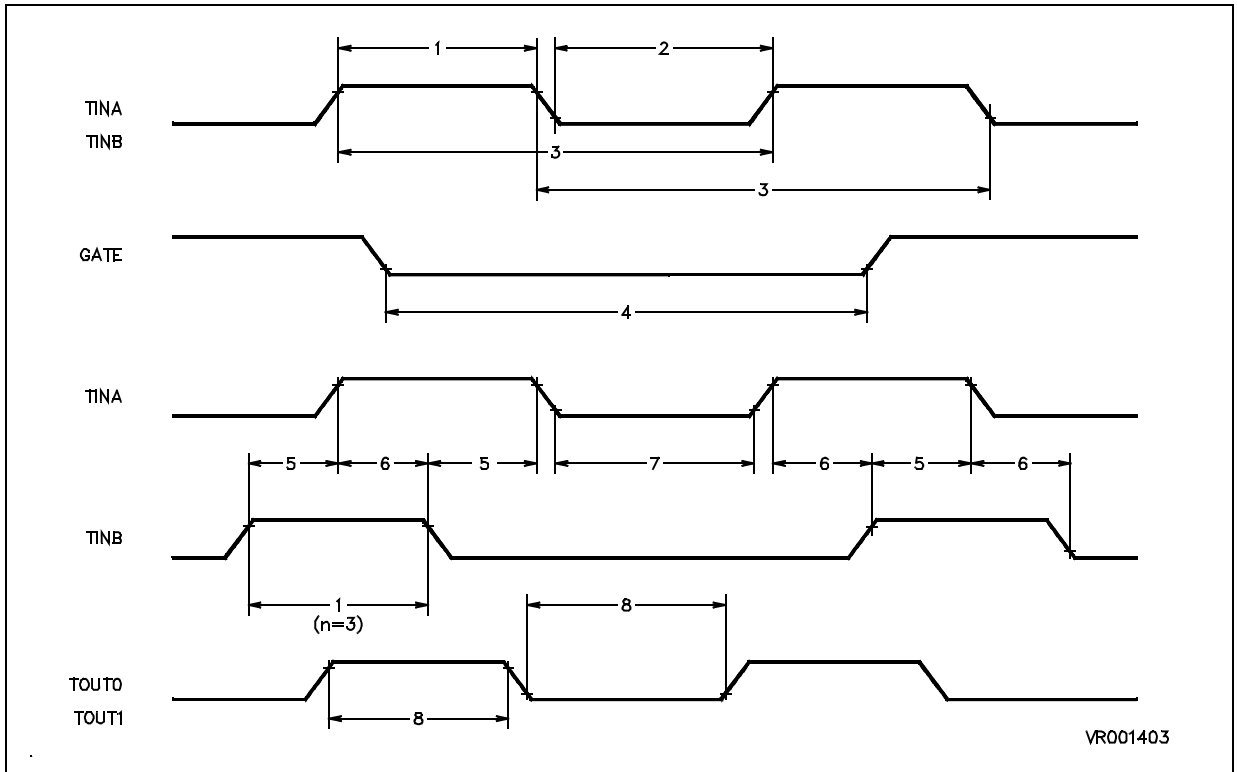

SCI-M TIMING TABLE

($V_{DD} = 5V \pm 10\%$, $T_A = -40^{\circ}C$ to $+125^{\circ}C$, $C_{Load} = 50pF$, $f_{INTCLK} = 24MHz$, unless otherwise specified)

N°	Symbol	Parameter	Condition	Value ⁽¹⁾		Unit
				Min	Max	
	F _{RxCKIN}	Frequency of RxCKIN	1x mode		$f_{INTCLK} / 8$	MHz
			16x mode		$f_{INTCLK} / 4$	MHz
	T _{WRxCKIN}	RxCKIN shortest pulse	1x mode	4 x Tck		s
			16x mode	2 x Tck		s
	F _{TxCKIN}	Frequency of TxCKIN	1x mode		$f_{INTCLK} / 8$	MHz
			16x mode		$f_{INTCLK} / 4$	MHz
	T _{WTxCKIN}	TxCKIN shortest pulse	1x mode	4 x Tck		s
			16x mode	2 x Tck		s
1	T _{sDS}	DS (Data Stable) before rising edge of RxCKIN	1x mode reception with RxCKIN	Tck / 2		ns
2	T _{dD1}	TxCKIN to Data out delay Time	1x mode transmission with external clock $C_{Load} < 50pF$		2.5 x Tck	ns
3	T _{dD2}	CLKOUT to Data out delay Time	1x mode transmission with CLKOUT	350		ns

Legend:

Tck = INTCLK period = Crystal Oscillator Clock period when CLOCK1 is not divided by 2;
 2 x Crystal Oscillator Clock period when CLOCK1 is divided by 2;
 Crystal Oscillator Clock period x PLL factor when the PLL is enabled.

Note 1: Values guaranteed by product characterization, not tested in production.

SCI TIMING

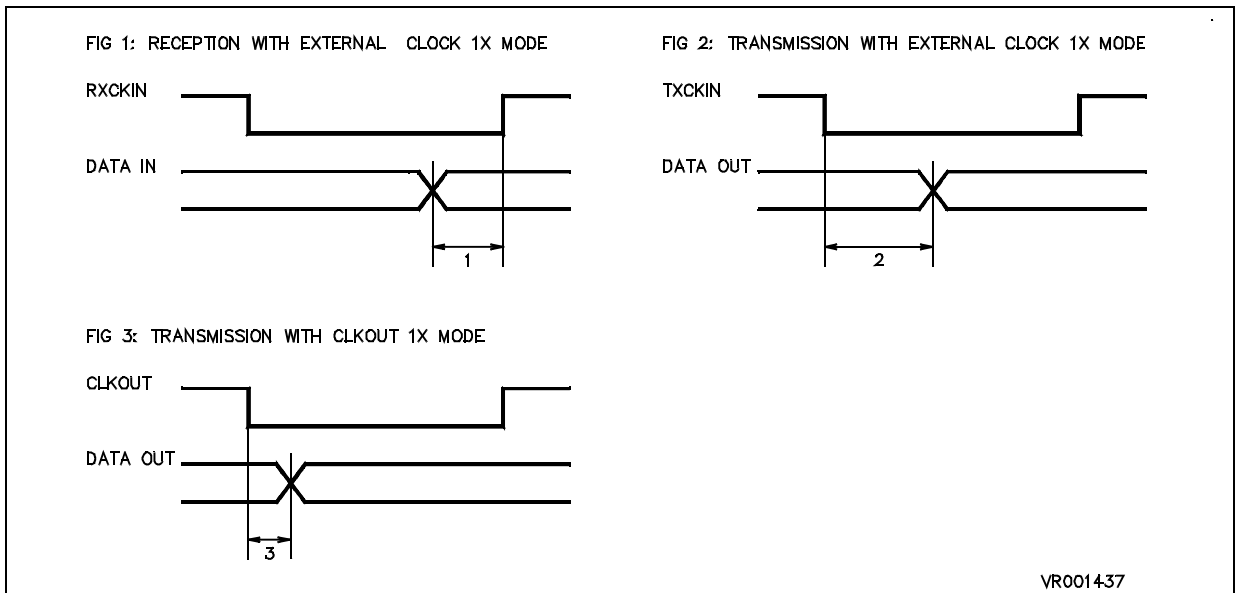

SPI TIMING TABLE

($V_{DD} = 5V \pm 10\%$, $T_A = -40^\circ\text{C}$ to $+125^\circ\text{C}$, $C_{Load} = 50\text{pF}$, $f_{INTCLK} = 24\text{MHz}$, unless otherwise specified)

N°	Symbol	Parameter	Condition	Value (1)		Unit
				Min	Max	
	f_{SPI}	SPI frequency	Master Slave	$f_{INTCLK} / 128$ 0	$f_{INTCLK} / 4$ $f_{INTCLK} / 2$	MHz
1	t_{SPI}	SPI clock period	Master Slave	$4 \times Tck$ $2 \times Tck$		ns
2	t_{Lead}	Enable lead time	Slave	40		ns
3	t_{Lag}	Enable lag time	Slave	40		ns
4	t_{SPL_H}	Clock (SCK) high time	Master Slave	80 90		ns
5	t_{SPL_L}	Clock (SCK) low time	Master Slave	80 90		ns
6	t_{SU}	Data set-up time	Master Slave	40 40		ns
7	t_H	Data hold time (inputs)	Master Slave	40 40		ns
8	t_A	Access time (time to data active from high impedance state)	Slave	0	120	ns
9	t_{Dis}	Disable time (hold time to high impedance state)				240
10	t_V	Data valid	Master (before capture edge) Slave (after enable edge)	$Tck / 4$	120	ns ns
11	t_{Hold}	Data hold time (outputs)	Master (before capture edge) Slave (after enable edge)	$Tck / 4$ 0		ns ns
12	t_{Rise}	Rise time (20% V_{DD} to 70% V_{DD} , $C_L = 200\text{pF}$)	Outputs: SCK, MOSI, MISO Inputs: SCK, MOSI, MISO, \overline{SS}		100 100	ns μs
13	t_{Fall}	Fall time (70% V_{DD} to 20% V_{DD} , $C_L = 200\text{pF}$)	Outputs: SCK, MOSI, MISO Inputs: SCK, MOSI, MISO, \overline{SS}		100 100	ns μs

Note:

Measurement points are V_{OL} , V_{OH} , V_{IL} and V_{IH} in the SPI Timing Diagram.

(1) Values guaranteed by design.

Legend:

Tck = INTCLK period = Crystal Oscillator Clock period when CLOCK1 is not divided by 2;

2 x Crystal Oscillator Clock period when CLOCK1 is divided by 2;

Crystal Oscillator Clock period x PLL factor when the PLL is enabled.

SPI Master Timing Diagram CPHA=0, CPOL=0

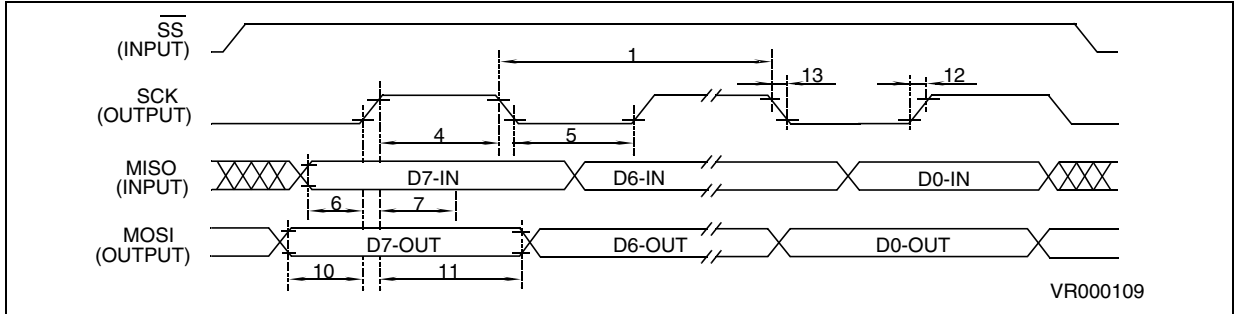

SPI Master Timing Diagram CPHA=0, CPOL=1

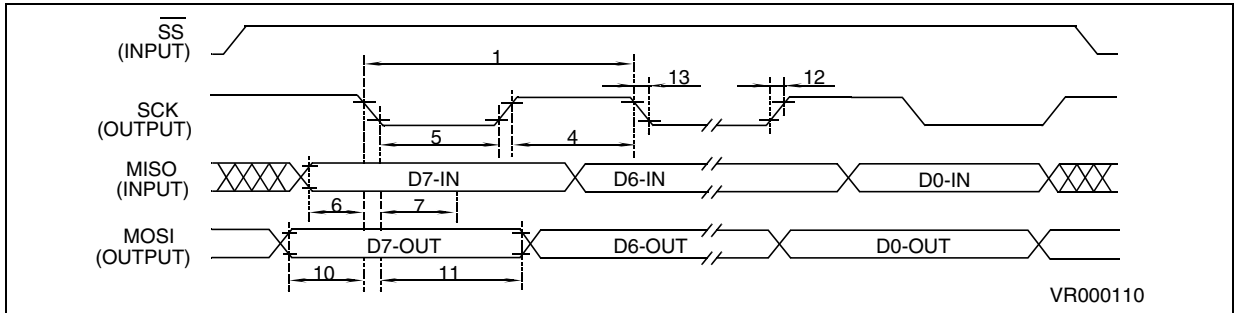

SPI Master Timing Diagram CPHA=1, CPOL=0

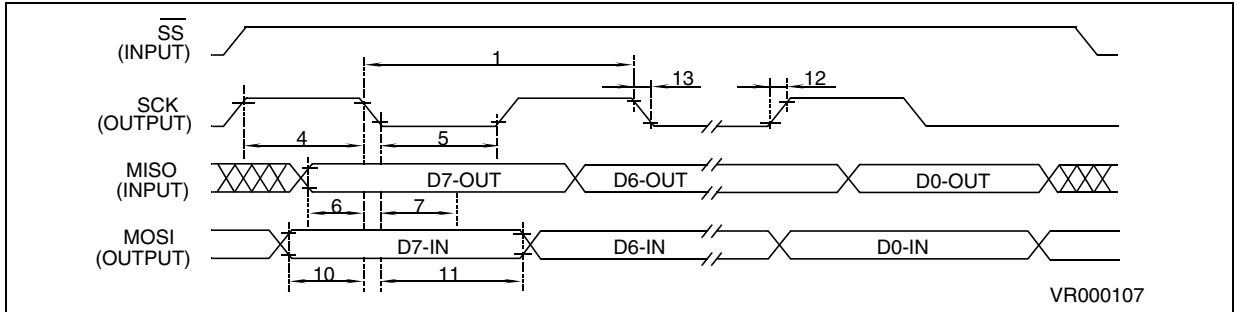

SPI Master Timing Diagram CPHA=1, CPOL=1

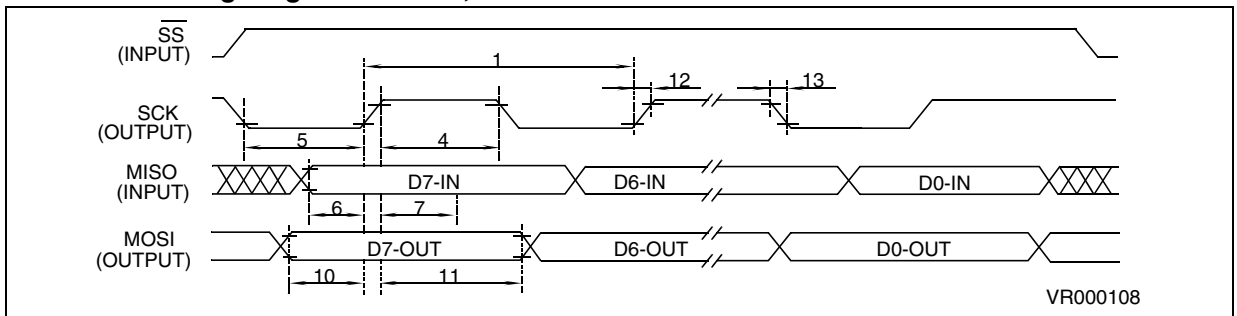

SPI Slave Timing Diagram CPHA=0, CPOL=0

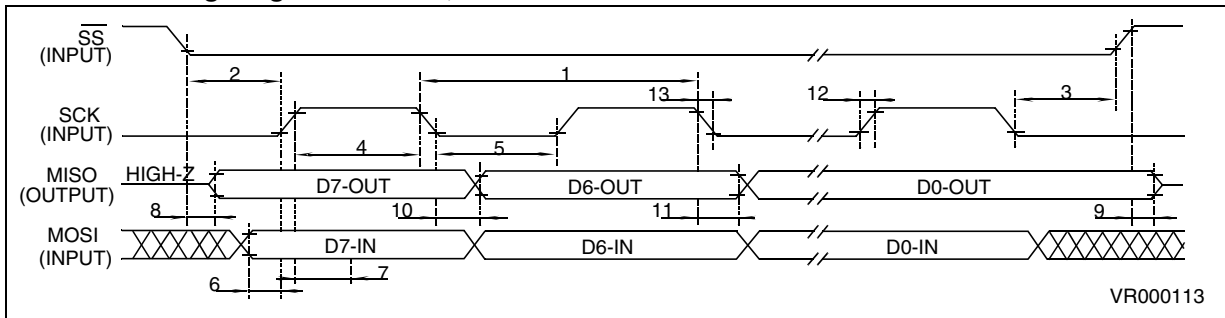

SPI Slave Timing Diagram CPHA=0, CPOL=1

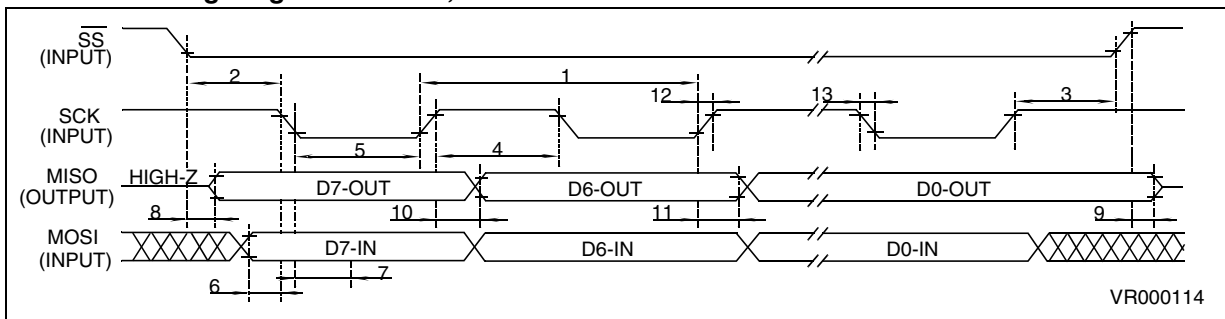

SPI Slave Timing Diagram CPHA=1, CPOL=0

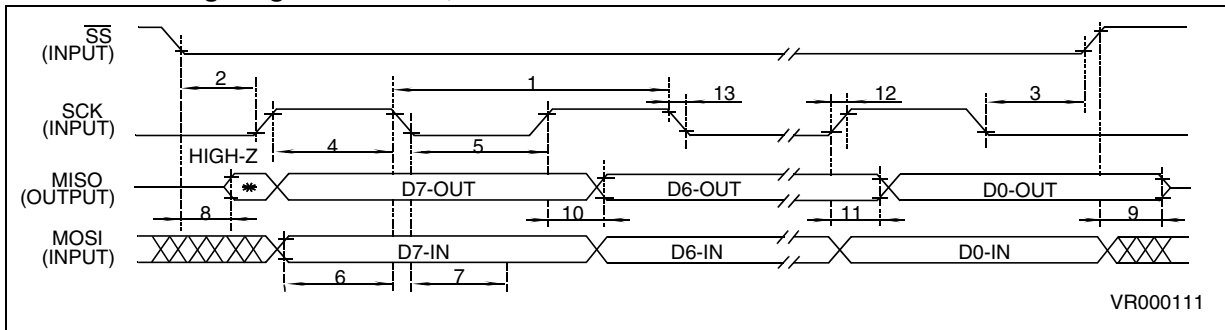

SPI Slave Timing Diagram CPHA=1, CPOL=1

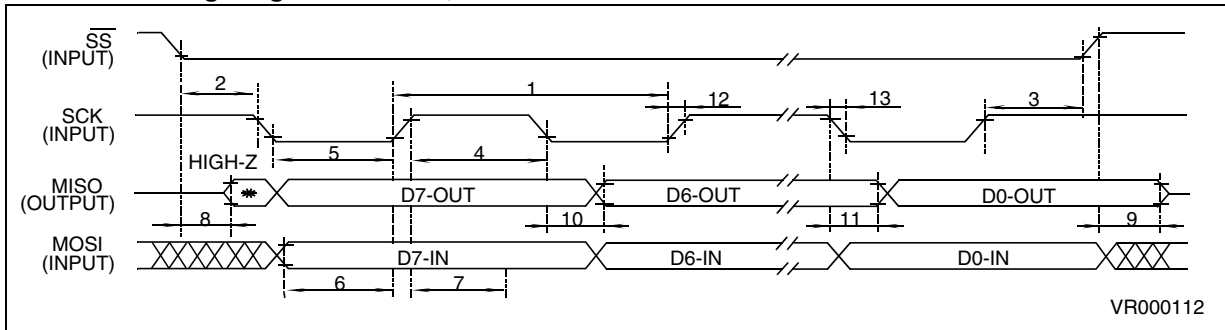

I²C/DDC-BUS TIMING TABLE

(V_{DD} = 5V ± 10%, T_A = -40°C to +125°C, C_{Load} = 50pF, f_{INTCLK} = 24MHz, unless otherwise specified)

Symbol	Parameter		Formula	Protocol Specifications				Unit	
				Standard I ² C		Fast I ² C			
				Min	Max	Min	Max		
f _{INTCLK}	Internal Frequency (Slave Mode)			2.5		2.5		MHz	
f _{SCL}	SCL clock frequency			0	100	0	400	kHz	
T _{BUF}	Bus free time between a STOP and START condition			4.7		1.3		µs	
T _{HIGH}	SCL clock high period			4.0		0.6		µs	
T _{LOW}	SCL clock low period	Standard Mode		4.7				µs	
		Fast Mode				1.3		µs	
T _{HD:STA}	Hold time START condition. After this period, the first clock pulse is generated		T _{LOW} + T _{ck}	4.0		0.6		µs	
T _{SU:STA}	Set-up time for a repeated START condition		T _{LOW} + T _{HIGH} - T _{HD:STA}	4.7		0.6		µs	
T _{HD:DAT}	Data hold time	FREQ[2:0] = 000	3 x T _{ck}	0 ^(1;2)		0 ^(1;2)	0.9 ^(1;3)	µs	
		FREQ[2:0] = 001	4 x T _{ck}						
		FREQ[2:0] = 010	4 x T _{ck}						
		FREQ[2:0] = 011	10 x T _{ck}						
T _{SU:DAT}	Data set-up time (Without SCL stretching)		T _{LOW} - T _{HD:DAT}	250 ⁽¹⁾		100 ⁽¹⁾		ns	
		Data set-up time (With SCL stretching)	FREQ[2:0] = 000						7 x T _{ck}
			FREQ[2:0] = 001						15 x T _{ck}
			FREQ[2:0] = 010						15 x T _{ck}
	FREQ[2:0] = 011	31 x T _{ck}							
T _R	Rise time of both SDA and SCL signals				1000 ⁽¹⁾	20+0.1Cb ⁽¹⁾		ns	
T _F	Fall time of both SDA and SCL signals				300 ⁽¹⁾	20+0.1Cb ⁽¹⁾		ns	
T _{SU:STO}	Set-up time for STOP condition		T _{LOW} + T _{HIGH} - T _{HD:STA}	4.0 ⁽¹⁾		0.6 ⁽¹⁾		ns	
C _b	Capacitive load for each bus line				400		400	pF	

Note:

- (1) Value guaranteed by design.
- (2) The ST9 device must internally provide a hold time of at least 300 ns for the SDA signal in order to bridge the undefined region of the falling edge of SCL
- (3) The maximum hold time of the START condition has only to be met if the interface does not stretch the low period of SCL signal

Legend:

T_{ck} = INTCLK period = Crystal Oscillator Clock period when CLOCK1 is not divided by 2;
 2 x Crystal Oscillator Clock period when CLOCK1 is divided by 2;
 Crystal Oscillator Clock period x PLL factor when the PLL is enabled.

C_b = total capacitance of one bus line in pF

FREQ[2:0] = Frequency bits value of I²C Own Address Register 2 (I2COAR2)

I²C TIMING

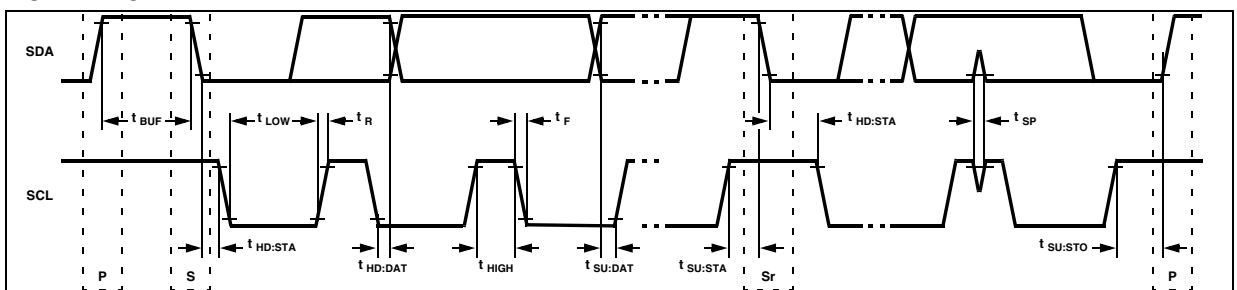

I²C/DDC-BUS TIMING TABLE (Cont'd)

The following table gives the values to be written in the I2CCCR and I2CECCR registers to obtain the required I²C SCL line frequency.

Table 70. SCL Frequency Table

f _{SCL} (kHz)	I2CCCR Value							
	f _{CPU} =12 MHz				f _{CPU} =24 MHz.			
	V _{DD} = 5 V							
	R _P =3.3kΩ		R _P =4.7kΩ		R _P =3.3kΩ		R _P =4.7kΩ	
	I2CECCR	I2CCCR	I2CECCR	I2CCCR	I2CECCR	I2CCCR	I2CECCR	I2CCCR
400	0	86h	0	85h	0	8Fh	0	8Eh
300	0	89h	0	89h	0	95h	0	94h
200	0	90h	0	8Fh	0	A2h	0	A2h
100	0	36h	0	36h	0	71h	0	70h
50	0	72h	0	72h	0	64h	1	64h

Legend:

R_P = External pull-up resistance

f_{SCL} = I²C speed

NA = Not achievable

Note:

- For speeds around 200 kHz, achieved speed can have ±5% tolerance
- For other speed ranges, achieved speed can have ±2% tolerance

The above variations depend on the accuracy of the external components used.

J1850 BYTE LEVEL PROTOCOL DECODER TIMING TABLE

($V_{DD} = 5V \pm 10\%$, $T_A = -40^\circ C$ to $+125^\circ C$, $C_{Load} = 50pF$, $f_{INTCLK} = 24MHz$, unless otherwise specified)

Symbol	Parameter	Value			Unit	Note
		Receive Mode		Transmission Mode		
		Min	Max	Nominal		
T_F	Symbols Filtered	0	≤ 7	-	μs	(1)(2)
T_{IB}	Invalid Bit Detected	> 7	≤ 34	-	μs	(1)(2)
T_{P0}	Passive Data Bit "0"	> 34	≤ 96	64	μs	(1)(2)(3)
T_{A0}	Active Data Bit "0"	> 96	≤ 163	128	μs	(1)(2)(3)
T_{P1}	Passive Data Bit "1"	> 96	≤ 163	128	μs	(1)(2)(3)
T_{A1}	Active Data Bit "1"	> 34	≤ 96	64	μs	(1)(2)(3)
T_{NBS}	Short Normalization Bit	> 34	≤ 96	64	μs	(1)(2)(3)
T_{NBL}	Long Normalization Bit	> 96	≤ 163	128	μs	(1)(2)(3)
T_{SOF}	Start Of Frame Symbol	> 163	≤ 239	200	μs	(1)(2)(3)
T_{EOD}	End Of Data Symbol	> 163	≤ 239	200	μs	(1)(2)(3)
T_{EOF}	End Of Frame Symbol	> 239	-	280	μs	(1)(2)(3)
T_{BRK}	Break Symbol	> 239	-	300	μs	(1)(2)(3)
T_{IDLE}	Idle Symbol	> 280	-	300	μs	(1)(2)(3)

Note:

- (1) Values obtained with internal frequency at 24 MHz (INTCLK), with CLKSEL Register set to 23.
- (2) In Transmission Mode, symbol durations are compliant to nominal values defined by the J1850 Protocol Specifications.
- (3) All values are reported with a precision of $\pm 1 \mu s$.

J1850 PROTOCOL TIMING

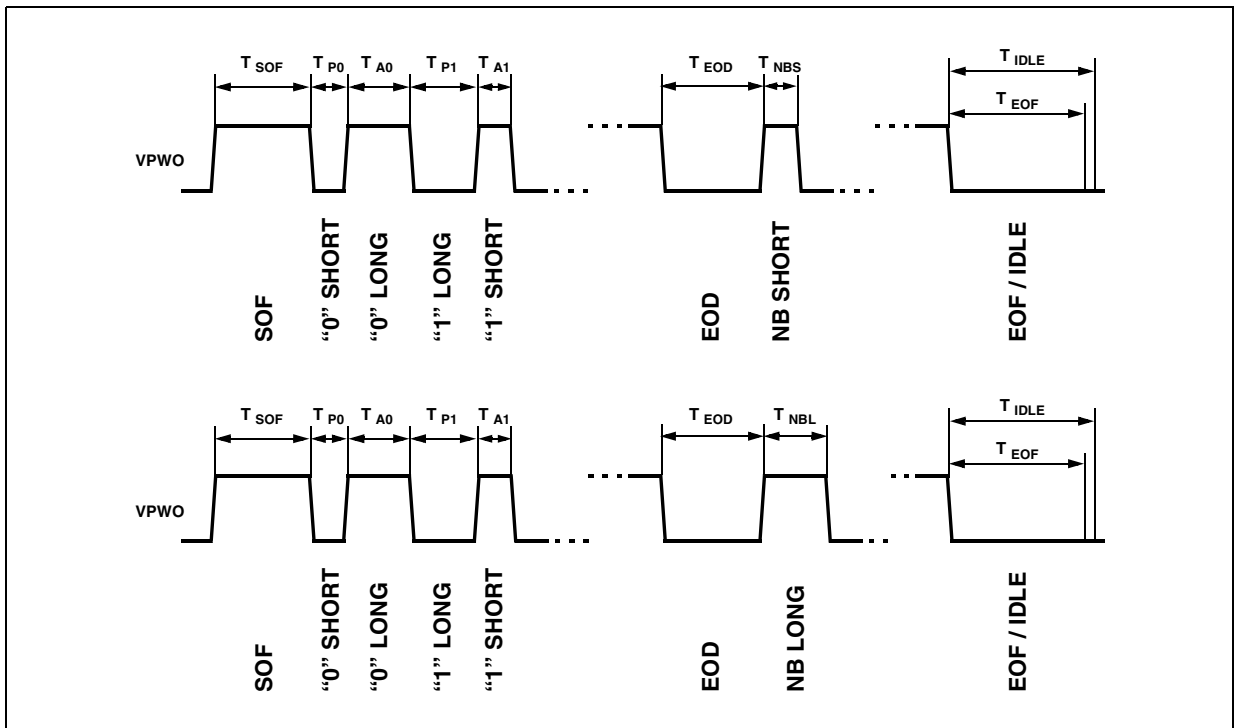

10-BIT ADC CHARACTERISTICS

Subject to general operating conditions for V_{DD} , f_{OSC} , and T_A , unless otherwise specified.

Symbol	Parameter	Conditions	Min	Typ ¹⁾	Max	Unit
f_{ADC}	ADC clock frequency		1		4	MHz
V_{AIN}	Conversion range voltage ⁽²⁾		AV_{SS}		AV_{DD}	V
V_{AINx}	Analog Input Voltage		-0.2		$AV_{DD} + 0.2$	
R_{AIN}	External source impedance				$10^{(3)}$	k Ω
C_{ADC}	Internal sample and hold capacitor			6 ^(3,4)		pF
R_{ADC}	Analog input pin impedance				1.7	k Ω
t_{STAB}	Stabilization time after ADC enable				10	μ s
t_{ADC}	Conversion time (Sample+Hold)	$f_{ADC} = 4$ MHz	7			$1/f_{ADC}$
	- Sample capacitor loading time - Hold conversion time			8 20		
I_{VDDA}	VDDA input current			1 ⁽⁴⁾		mA

Figure 161. Typical Application with ADC

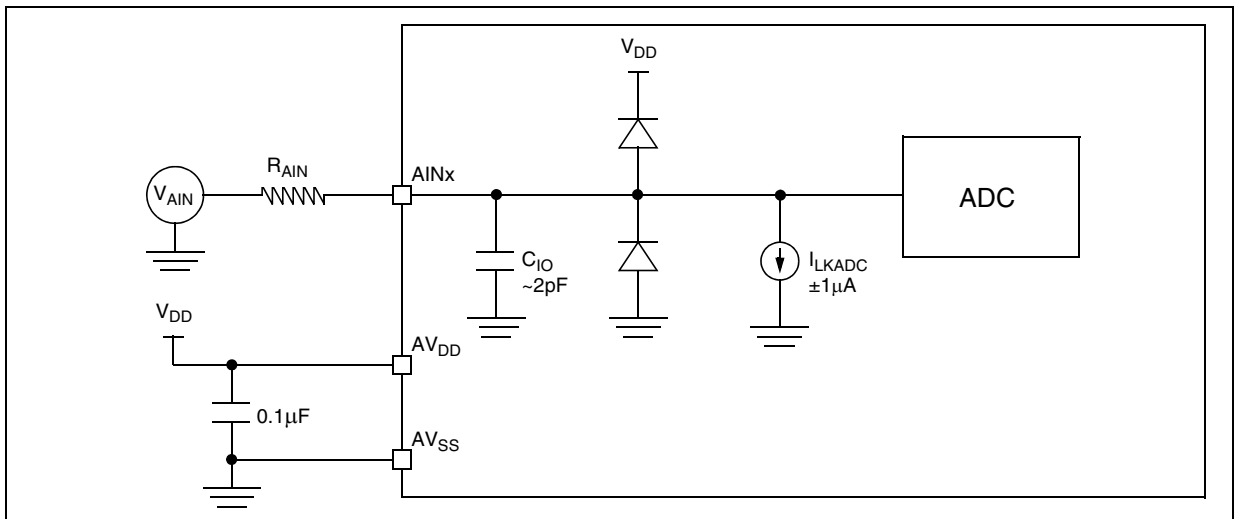

Notes:

1. Unless otherwise specified, typical data is based on $T_A=25^\circ\text{C}$ and $V_{DD}-V_{SS}=5\text{V}$. These values are given only as design guidelines and are not tested.
2. V_{AIN} may exceed AV_{SS} or AV_{DD} . However the conversion result in these cases will be 0000h or FFC0h respectively.
3. Any external serial impedance will downgrade the ADC accuracy (especially for resistance greater than 10 k Ω). Data based on characterization results, not tested in production.
4. Value guaranteed by design.

10-BIT ADC CHARACTERISTICS (Cont'd)

ADC Accuracy ($V_{DD}=5V\pm 10\%$, $T_A=-40^\circ C$ to $+125^\circ C$)

Symbol	Parameter	Conditions	Typ ¹⁾	Max	Unit
	Monotonicity	Guaranteed ²⁾			
	No missing codes	Guaranteed ²⁾			
IEtI	Total unadjusted error ³⁾	$f_{ADC} = 4MHz$	1.5	6	LSB
IEoI	Offset error ³⁾		1	5.5	
IEgI	Gain Error ³⁾		1.5	6	
IEdI	Differential linearity error ³⁾		0.5	1.5	
IEI	Integral linearity error ³⁾		0.5	1.5	

1. Typical data is based on $T_A=25^\circ C$, $V_{dd}=5V$
2. Monotonicity and No Missing Codes are guaranteed by design.
3. Refer to Figure 162. for the definition of these parameters.

Figure 162. ADC Accuracy Characteristics

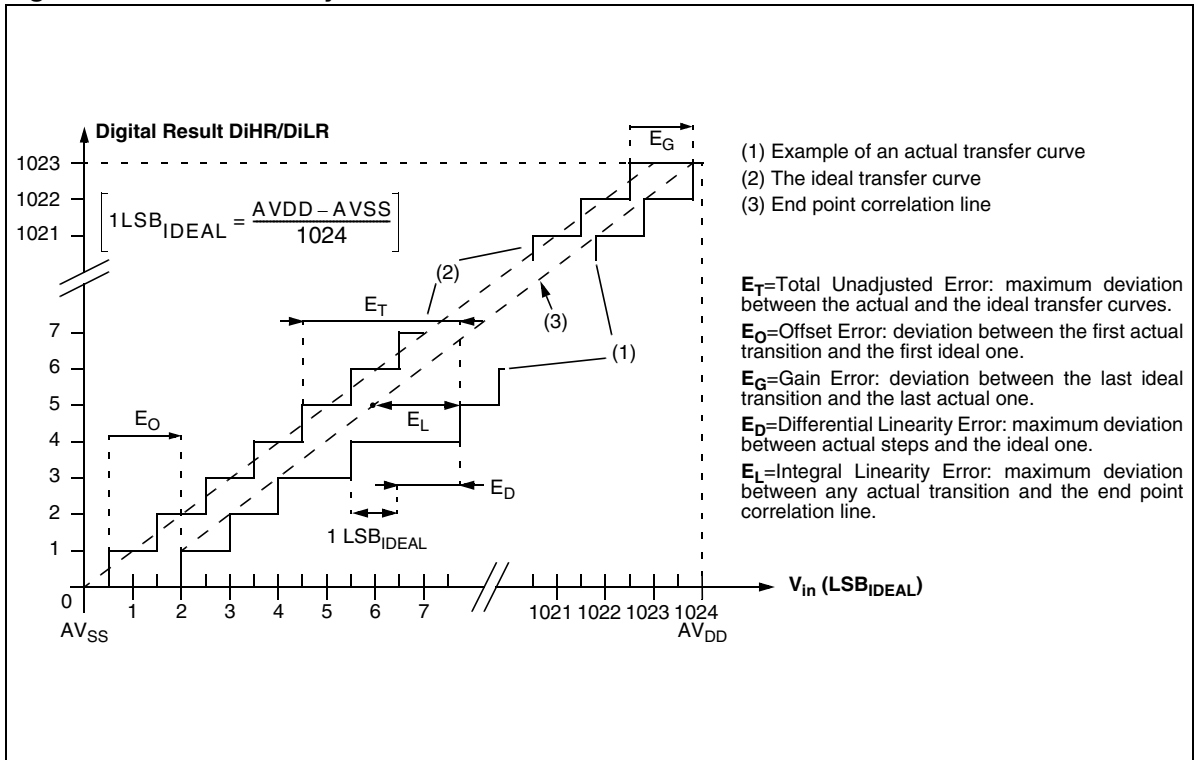

12 GENERAL INFORMATION

12.1 ORDERING INFORMATION

Figure 163. Device Types

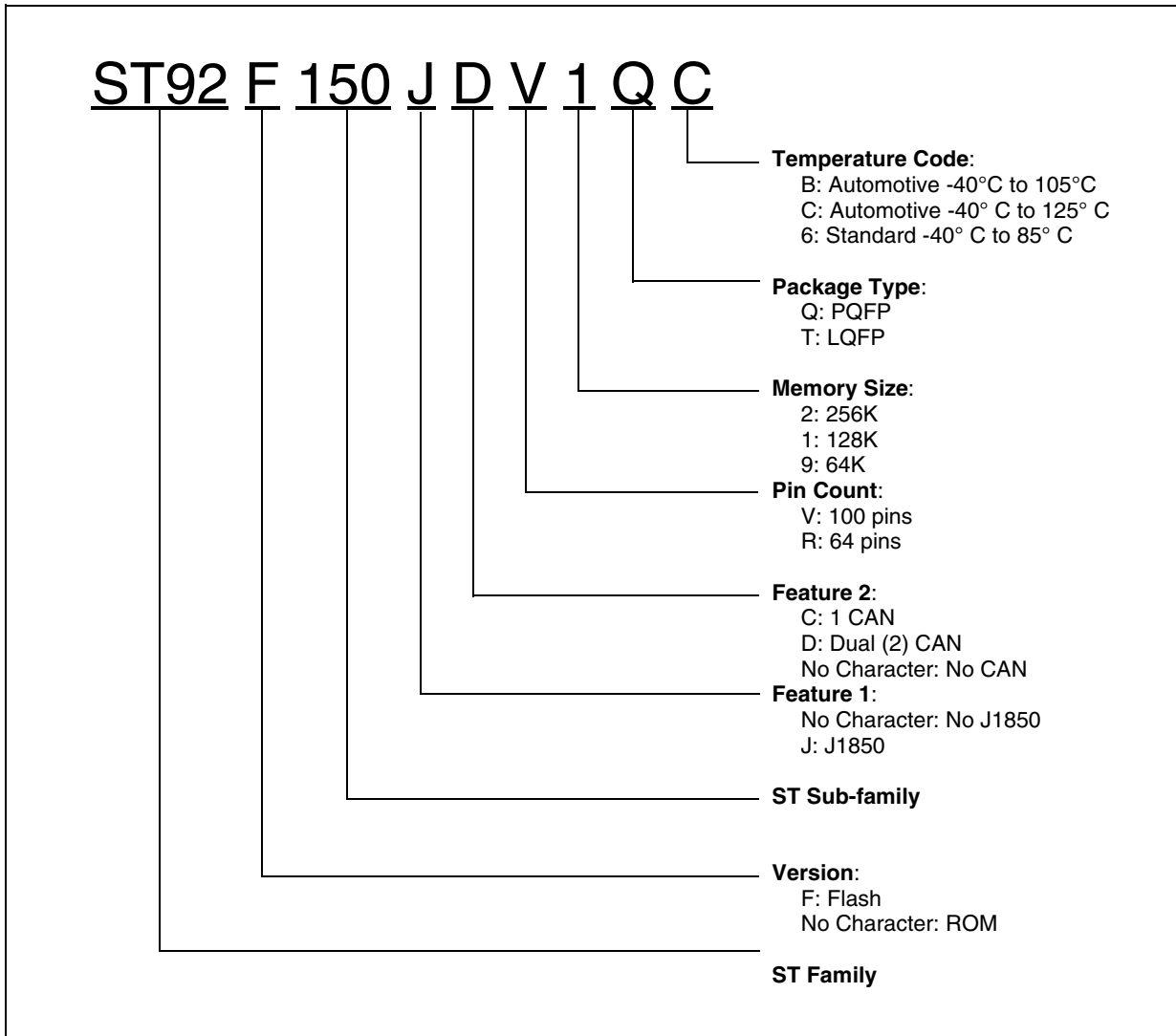

12.2 VERSION-SPECIFIC SALES CONDITIONS

To satisfy the different customer requirements and to ensure that ST Standard Microcontrollers will consistently meet or exceed the expectations of each Market Segment, the Codification System for Standard Microcontrollers clearly distinguishes products intended for use in automotive environments, from products intended for use in non-automotive environments. It is the responsibility of the Customer to select the appropriate product for his application.

ORDERING INFORMATION (Cont'd)

Table 71. Supported part numbers

Part Number	Program Memory (Bytes)	RAM (Bytes)	Package	Temperature	
ST92F124R9TB	64K FLASH	2K	LQFP64	-40°C to 105°C	
ST92F150CR9TB			LQFP64	-40°C to 105°C	
ST92F150CV9TB			LQFP100	-40°C to 105°C	
ST92F124R1C6	128K FLASH	4K	LQFP64	-40°C to 85°C	
ST92F124V1QB			PQFP100	-40°C to 105°C	
ST92F124V1Q6			PQFP100	-40°C to 85°C	
ST92F124V1TB			LQFP100	-40°C to 105°C	
ST92F124V1T6			LQFP100	-40°C to 85°C	
ST92F150CR1TB			LQFP64	-40°C to 105°C	
ST92F150CV1QB			PQFP100	-40°C to 105°C	
ST92F150CV1TB			LQFP100	-40°C to 105°C	
ST92F150JDV1QC			6K	PQFP100	-40°C to 125°C
ST92F150JDV1TC				LQFP100	
ST92F250CV2TC			256K FLASH	8K	LQFP100
ST92F250CV2T6	LQFP100				
ST92F250CV2QB	PQFP100				
ST92F250CV2TB	LQFP100				

Contact ST sales office for product availability

12.3 PACKAGE MECHANICAL DATA

Figure 164. 64-Pin Low Profile Quad Flat Package

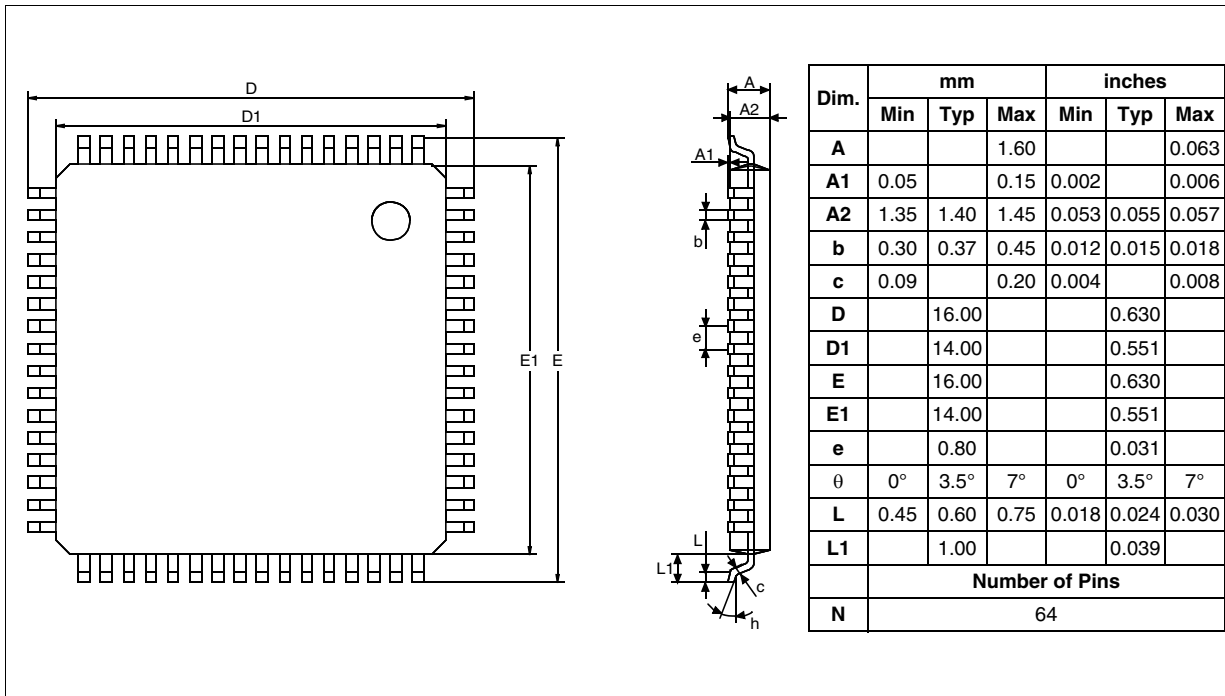

Figure 165. 100-Pin Low Profile Quad Flat Package

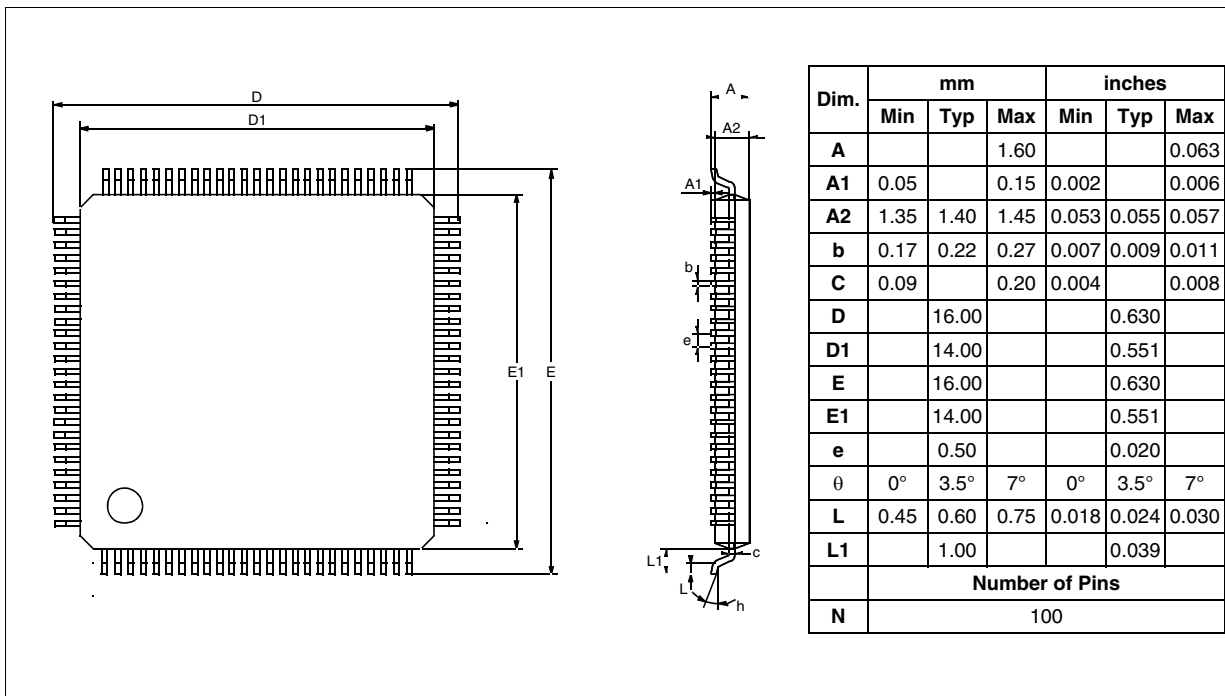
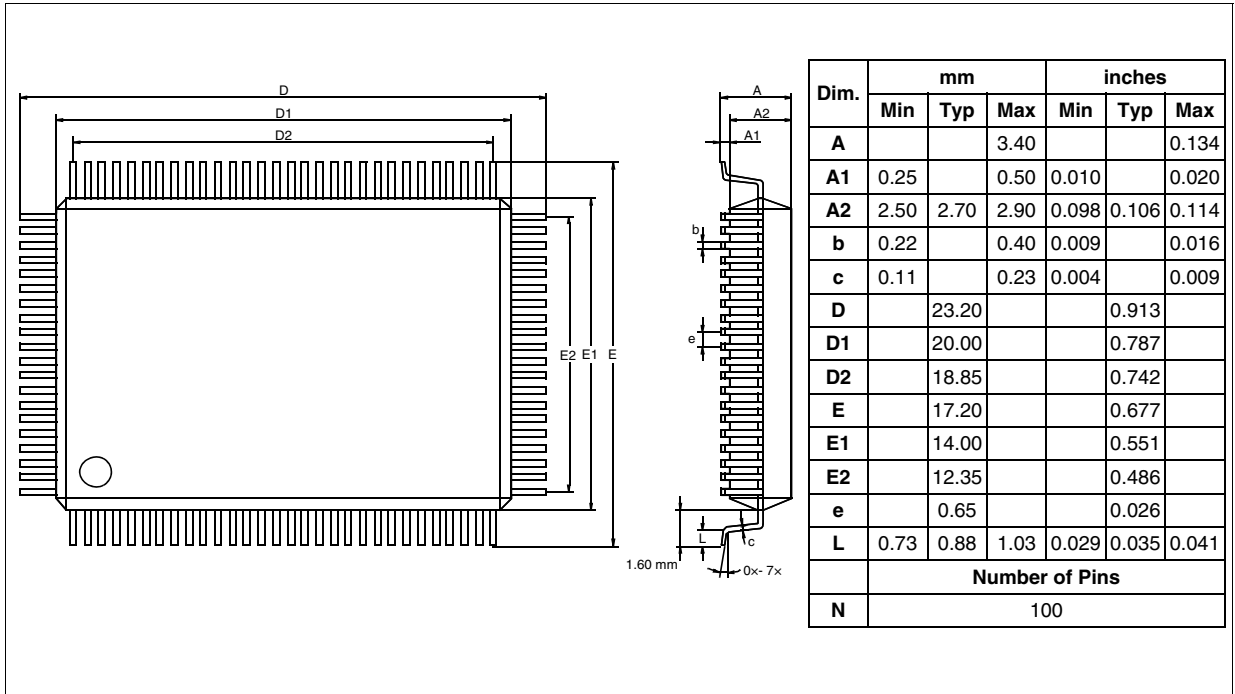

Figure 166. 100-Pin Plastic Quad Flat Package



12.4 SOLDERING AND GLUEABILITY INFORMATION

In order to meet environmental requirements, ST offers these devices in ECOPACK® packages. These packages have a lead-free second level interconnect. The category of second level interconnect is marked on the package and on the inner box label, in compliance with JEDEC Standard JESD97. The maximum ratings related to soldering conditions are also marked on the inner box label.

ECOPACK is an ST trademark. ECOPACK® specifications are available at www.st.com.

12.5 DEVELOPMENT TOOLS

STMicroelectronics offers a range of hardware and software development tools for the ST9 microcontroller family. Full details of tools available for the ST9 from third party manufacturers can be obtained from the STMicroelectronics Internet site:

➔ <http://mcu.st.com>.

Tools from these manufacturers include realtime kernel software and gang programmers.

Table 72. STMicroelectronics Development Tools

Supported Products	Emulator	Programming Board
ST92F124 (LQFP64, LQFP100) ST92F150 (LQFP64, LQFP100, PQFP100) ST92F250 ⁽¹⁾ (LQFP100, PQFP100)	ST92F150-EMU2	ST92F150-EPB/EU ST92F150-EPB/US ST92F150-EPB/UK

Note 1: The I²C 1 and the general purpose I/Os P3.0, P6.6 and P6.7 cannot be emulated by this emulator. Since the upper 128Kbytes of Flash memory are emulated with a RAM memory, the programming operations on the F4 and F5 Flash sectors are not emulated.

12.5.1 Socket and Emulator Adapter Information

For information on the type of socket that is supplied with ST92F150-EMU2, refer to the suggested list of sockets in [Table 73](#).

Note: Before designing the board layout, it is recommended to check the overall dimensions of the socket as they may be greater than the dimensions of the device.

For footprint and other mechanical information about these sockets and adapters, refer to the manufacturer's datasheet (available from www.yamaichi.de for LQFP100 and PQFP100 and from www.cabgmbh.com for LQFP64).

Table 73. Suggested List of Socket Types

Device	Socket (supplied with ST92F150-EMU2)	Emulator Adapter (supplied with ST92F150-EMU2)
LQFP64 14 x14	CAB 3303262	CAB 3303351
LQFP100 14 x14	YAMAICHI IC149-100-*25-*5	YAMAICHI ICP-100-5
PQFP100 14 x 20	YAMAICHI IC149-100-*14-*5	YAMAICHI ICP-100-4-4

13 KNOWN LIMITATIONS

Limitations described in this section apply to all silicon revisions. They are listed in the following table.

Please contact your nearest sales office for further information.

Additional limitations exist on specific silicon revisions identified by the following trace codes:

- ST92F124 Gxxxxxxx1
or 1 ST92F124 xxxxx VG
- ST92F150 AxxxxxxxZ
- ST92F150 AxxxxxxxY
or Y ST92F150 xxxxx VA
- ST92F250 AxxxxxxxA
or A ST92F250 xxxxx VA

Table 74. List of limitations

Section	Limitation
Section 13.1	"FLASH ERASE SUSPEND LIMITATIONS
Section 13.2	"FLASH CORRUPTION WHEN EXITING STOP MODE
Section 13.3	"I2C LIMITATIONS
Section 13.4	"SCI-A AND CAN INTERRUPTS
Section 13.5	"SCI-A MUTE MODE
Section 13.6	"CAN FIFO CORRUPTION WHEN 2 FIFO MESSAGES ARE PENDING
Section 13.7	"MFT DMA MASK BIT RESET WHEN MFT0 DMA PRIORITY LEVEL IS SET TO 0
Section 13.8	"EMULATION CHIP LIMITATIONS

13.1 FLASH ERASE SUSPEND LIMITATIONS

13.1.1 Description

In normal operation, the FSUSP bit (bit 2 in the FCR register) must be set to suspend the current Sector Erase operation in Flash memory in order to access a sector not being erased. The Flash sector erase operation is done in 3 different steps:

1. Program all addresses to 0 on selected sectors
2. Erase and erase verify
3. Reprogramming

If the erase suspend is performed during Steps 1 and 2, the flash works correctly. If the erase suspend is performed during Step 3, the PGER bit (bit

6 in the FESR1 register) is set although no program error occurred.

13.1.2 Workaround

After a Sector Erase suspend operation, the software must check the status register to detect if an erase error occurred (the corresponding sector must be discarded). Then the software must reset the FEERR bit. This automatically resets the flash status register.

Whatever the state of the PGER bit at the end of the erase operation, it will not impact the application and an erase error is still detected.

KNOWN LIMITATIONS (Cont'd)

13.2 FLASH CORRUPTION WHEN EXITING STOP MODE

Description

Under very specific conditions, the first read performed in flash memory by the core when exiting stop mode may be corrupted.

Impact on application

As this first read is an opcode, this corruption may lead to an unpredictable behavior of the application.

Workaround**Description**

In ST92F124/F150/F250 datasheet, there is a warning in the WUCTRL register description:

“In order to avoid to execute register write instructions after a correct STOP bit setting sequence and before entering the STOP mode, it is mandatory to execute 3 NOP instructions after the STOP bit setting sequence.”

The workaround is to replace these 3 NOPs by the following assembly code:

```
nop
ldw RRx, 0
```

RRx is an unused register in the register file.

In a C language software, implement the following code.

Implementation

Declare a dummy variable in the register file (for example in RR0 16-bit register)

```
#pragma register_file Dummy_16bit_data 0
volatile unsigned int Dummy_16bit_data;
```

And replace the actual STOP bit setting sequence (specified in datasheet):

```
spp(WU_PG);
WU_CTLR = WUm_wuit | WUm_id1s | WUm_stop;
WU_CTLR = WUm_wuit | WUm_id1s;
WU_CTLR = WUm_wuit | WUm_id1s | WUm_stop;
asm("nop");
asm("nop");
asm("nop");
```

KNOWN LIMITATIONS (Cont'd)

By:

```
spp(WU_PG);
WU_CTLR = WUm_wuit | WUm_id1s | WUm_stop;
WU_CTLR = WUm_wuit | WUm_id1s;
WU_CTLR = WUm_wuit | WUm_id1s | WUm_stop;
asm("nop");
Dummy_16bit_data = 0;
```

Compiled code (with -O2 optimization option) and hexa is:

C language	Assembly	Hexa	Comment
WU_CTLR = WUm_wuit WUm_id1s WUm_stop;	ld @WU_CTLR, #7	F5 F9 07	
WU_CTLR = WUm_wuit WUm_id1s;	ld @WU_CTLR, #3	F5 F9 03	
WU_CTLR = WUm_wuit WUm_id1s WUm_stop;	ld @WU_CTLR, #7	F5 F9 07	The CORE executes the following NOP and prefetch the 2 following bytes (BF and 00)
NOP	nop	FF	
Dummy_16bit_data = 0;	ldw RR0,#0	BF 00 00 00	The two first bytes fetch in flash after wake up are 00 00 RR0 is always filled with 00 RR0 is not used in the software

KNOWN LIMITATIONS (Cont'd)

13.3 I2C LIMITATIONS

Limitations	Description	Mode
Section 13.3.1	Start condition ignored	Mustimaster mode
Section 13.3.2	Missing bus error	Master transmitter mode
Section 13.3.3	AF bit (acknowledge failure flag)	Transmitter mode (Master and Slave)
Section 13.3.4	BUSY bit	Mustimaster mode
Section 13.3.5	ARLO (arbitration lost)	Multimaster mode
Section 13.3.6	BUSY flag	All

13.3.1 Start condition ignored in multimaster mode

Description

In multimaster configurations, if the ST9 I2C receives a START condition from another I2C master after the START bit is set in the I2CCR register and before the START condition is generated by the ST9 I2C, it may ignore the START condition from the other I2C master. In this case, the ST9 master will receive a NACK from the other device.

Workaround

On reception of the NACK, ST9 can send a re-start and Slave address to re-initiate communication.

13.3.2 Missing BUS error in master transmitter mode

Description

BERR will not be set if an error is detected during the first or second pulse of each 9-bit transaction.

Single Master Mode:

If a Start or Stop is issued during the first or second pulse of a 9-bit transaction, the BERR flag will not be set and transfer will continue however the BUSY flag will be reset.

Multimaster Mode:

Normally the BERR bit would be set whenever unauthorized transmission takes place while transfer is already in progress. However, an issue will arise if an external master generates an unauthorized Start or Stop while the I2C master is on the first or second pulse of a 9-bit transaction.

Workaround**Single Master Mode:**

Slave devices should issue a NACK when they receive a misplaced Start or Stop. The reception of a NACK or BUSY by the master in the middle of communication gives the possibility to reinitiate transmission.

Multimaster Mode:

It is possible to work around the problem by polling the BUSY bit during I2C master mode transmission. The resetting of the BUSY bit can then be handled in a similar manner as the BERR flag being set.

KNOWN LIMITATIONS (Cont'd)

13.3.3 AF bit (acknowledge failure flag) in transmitter mode (slave and master)

Description

The AF bit is cleared by reading the I2CSR2 register. However, if read before the completion of the transmission, the AF flag will be set again, thus possibly generating a new interrupt.

Workaround

Software must ensure either that the SCL line is back at 0 before reading the SR2 register, or be able to correctly handle a second interrupt during the 9th pulse of a transmitted byte.

13.3.4 BUSY flag in multimaster mode

Description

The BUSY flag is NOT updated when the interface is disabled (PE=0). This can have consequences when operating in Multimaster mode; i.e. a second active I2C master commencing a transfer with an unset BUSY bit can cause a conflict resulting in lost data.

Workaround

Check that the I2C is not busy before enabling the I2C Multimaster cell.

13.3.5 ARLO (arbitration lost) flag in multimaster mode

Description

In a Multimaster environment, when the interface is configured in Master Receive mode it does not perform arbitration during the reception of the Acknowledge Bit. Mishandling of the ARLO bit from the I2CSR2 register may occur when a second master simultaneously requests the same data from the same slave and the I2C master does not acknowledge the data. The ARLO bit is then left at 0 instead of being set.

Workaround

None

13.3.6 BUSY flag gets cleared when BUS error occurs

Description

BUSY bit gets cleared when the BUS error occurs but the bus is actually BUSY (SCL line shows CLK pulses). Contradictory, M/SL bit is unaffected on BUS error

Workaround

If a Bus Error occurs, a Stop or a repeated Start condition should be generated by the Master to re-synchronize communication, get the transmission acknowledged and the bus released for further communication

KNOWN LIMITATIONS (Cont'd)

13.4 SCI-A AND CAN INTERRUPTS

Description

SCI-A interrupt (I0 channel) and CAN interrupts (channels E0, E1, F0, F1, G0, G1, H0, H1) do not respond when the CPUCLK is prescaled (MODER register).

Workaround

Avoid using CPU prescaler when SCI-A and/or CAN interrupts are used in the application.

13.5 SCI-A MUTE MODE

13.5.1 Mute Mode Description

The SCI can be put in Mute mode waiting for an Idle line detection or an Address Mark detection, and discarding all other byte transmissions. This is done by setting the RWU (Receiver wake-up) bit in the SCICR2 register (R244, page 26). This bit can be reset either by software, to leave the Mute mode, or by hardware when a wake up condition has been reached.

Figure 1. Mute Mode Mechanism on address mark

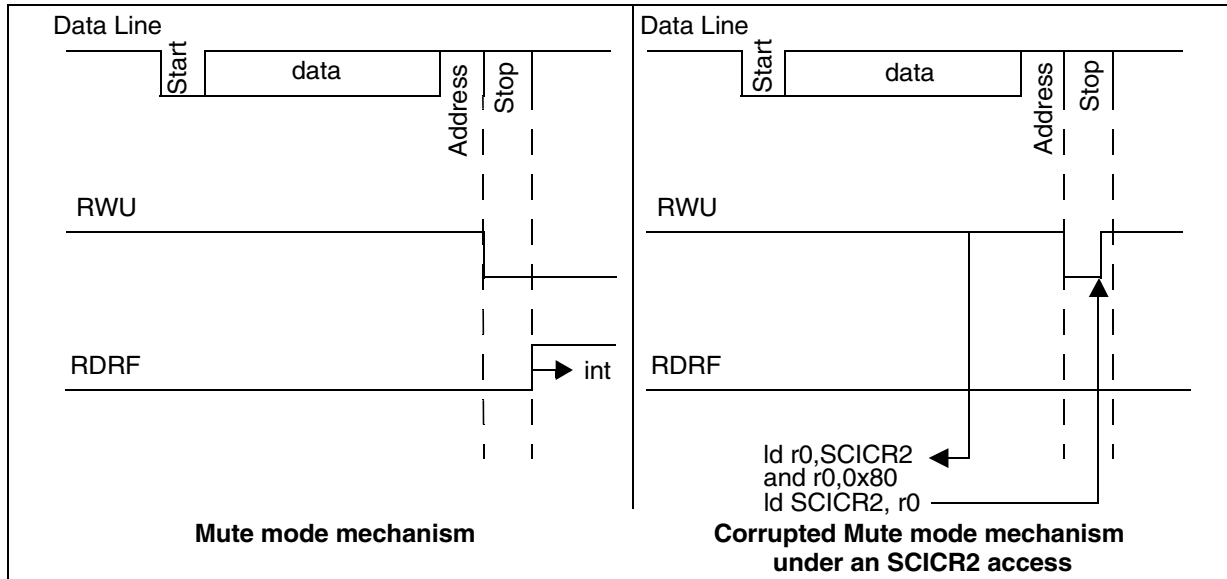

Consequence

The address byte is lost and the SCI-A is again in Mute mode.

A received data is indicated by the RDRF (Read Data Ready Flag) bit in the SCISR register (R240, page 26). This status bit is evaluated at the end of the stop bit. If the RWU bit is in the set state at the end of the stop bit, the data is not loaded in the data register and the RDRF bit is not set.

On the contrary, if the RWU bit is in the reset state at the end of the stop bit the data is loaded in the data register and the RDRF bit is set.

13.5.2 Limitation Description

The SCICR2 also contains the following configuration bits: Interrupt Enable, Transmitter Enable, Receiver Enable and Send Break.

When the value of one of these bits is modified by software, the SCICR2 register is read, its value is modified and reloaded in the SCICR2 register. If the SCI-A is in Mute mode during the read operation (RWU=1) and if an address mark event occurs (resetting the RWU bit) before the write operation, the RWU bit is set before the end of the stop bit. In this case, the RDRF bit is not set, the data is not received and no flag indicates the lost of the data.

13.5.3 Workaround

If you need to disable the SCI-A interrupt while it is in Mute mode, use the global interrupt mask in the dedicated interrupt controller, refer to Section 5.7 "Standard Interrupts" in the datasheet. Do not change the TE, RE and SBK bits in the SCICR2 register while the SCI-A is in Mute mode.

KNOWN LIMITATIONS (Cont'd)

13.6 CAN FIFO CORRUPTION WHEN 2 FIFO MESSAGES ARE PENDING

Description

Under certain conditions, FIFO corruption can occur in the following cases:

WHEN a bxCAN RX FIFO already holds 2 messages (i.e. FMP==2)

AND the application releases the same FIFO (with the instruction CANx_CTRL_CRFRy l= CRF_rfom;
 x=0 for the CAN_0 cell
 x=1 for the CAN_1 cell
 y=0 for the Receive FIFO 0
 y=1 for the Receive FIFO 1)

WHILE the bxCAN requests the transfer of a new receive message into the FIFO (this lasts one CPU cycle)

THEN the internal FIFO pointer is not updated
 BUT the FMP bits are updated correctly

Impact on Application:

As the FIFO pointer is not updated correctly, this causes the last message received to be overwritten by any incoming message. This means one message is lost as shown in the example in Figure 2 The bxCAN will not recover normal operation until a device reset occurs.

Figure 2. FIFO Corruption

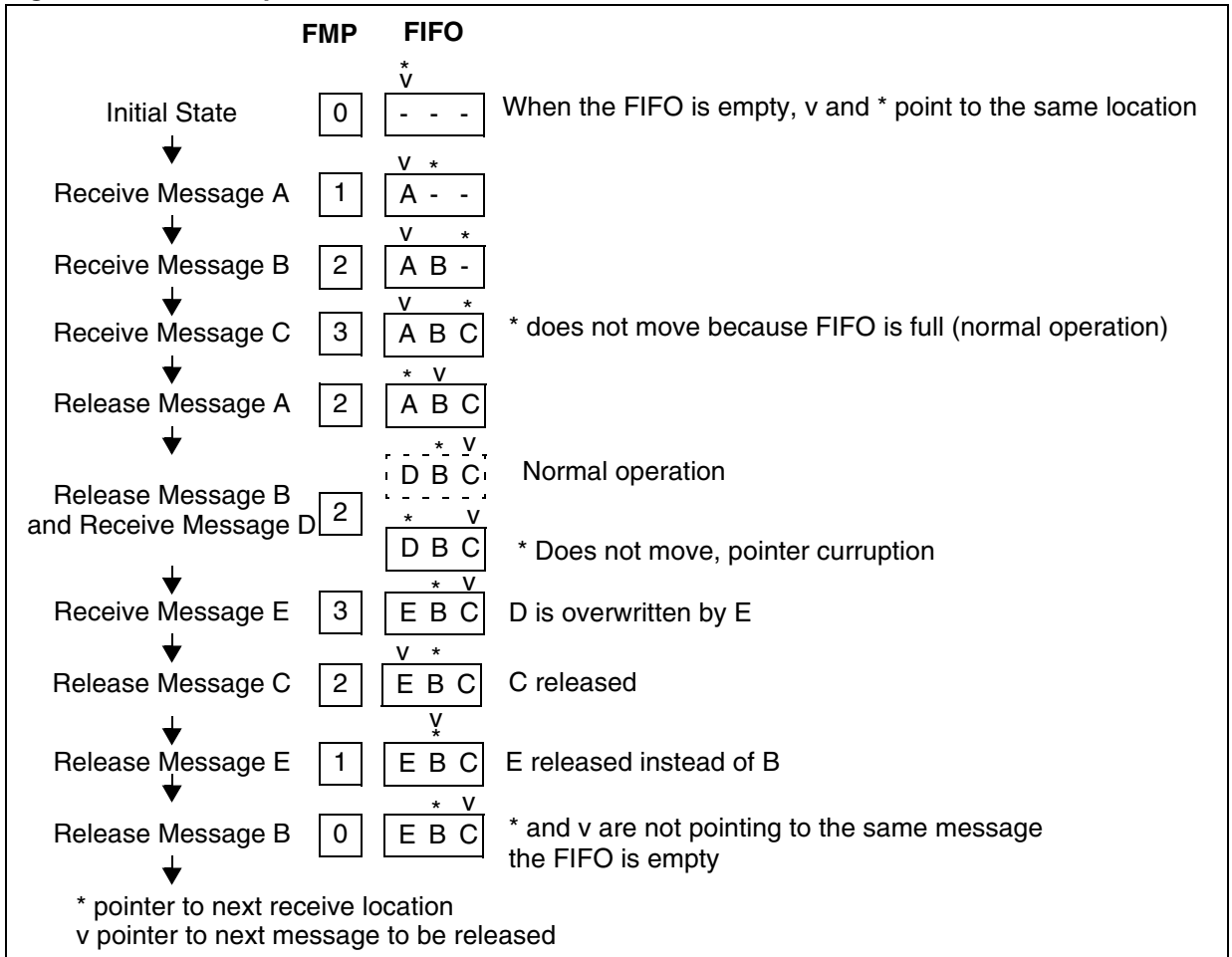

KNOWN LIMITATIONS (Cont'd)**Workaround 1**

:

The workaround is to replace any occurrence of

```
spp (CANx_CTRL_PG);
CANx_CTRL_CRFRy |= CRFR_rfom;
```

by:

```
spp(CANx_CTRL_PG);
if ((CANx_CTRL_CRFRy & 0x03) == 0x02)
while ((CANx_CTRL_CMSRy & 0x20) && (CANx_CTRL_CDGRy & 0x08));
CANx_CTRL_CRFRy |= CRFR_rfom;
```

x=0 for the CAN_0 cell
x=1 for the CAN_1 cell

y=0 for the Receive FIFO 0
y=1 for the Receive FIFO 1

Explanation of Workaround 1

First, we need to make sure no interrupt can occur between the test and the release of the FIFO to avoid any added delay.

The workaround checks if the first 2 FIFO levels are already full (FMP = 2) as the problem happens only in this case.

If FMP≠2 we release the FIFO immediately, if FMP=2, we monitor the reception status of the cell.

The reception status is available in the CMSR register bit 5 (REC bit).

Note: The REC bit was called RX in older versions of the datasheet.

If the cell is not receiving, then REC bit in CMSR is at 0, the software can release the FIFO immediately: there is no risk.

If the cell is receiving, it is important to make sure the release of the mailbox will not happen at the

time when the received message is loaded into the FIFO.

We could simply wait for the end of the reception, but this could take a long time (200µs for a 100-bit frame at 500kHz), so we also monitor the Rx pin of the microcontroller to minimize the time the application may wait in the while loop.

We know the critical window is located at the end of the frame, 6+ CAN bit times after the acknowledge bit (exactly six full bit times plus the time from the beginning of the bit to the sample point). Those bits represent the acknowledge delimiter + the end of frame slot.

We know also that those 6+ bits are in recessive state on the bus, therefore if the CAN Rx pin of the device is at '0', (reflecting a CAN dominant state on the bus), this is early enough to be sure we can release the FIFO before the critical time slot.

Therefore, if the device hardware pin Rx is at 0 and there is a reception on going, its message will be transferred to the FIFO only 6+ CAN bit times later at the earliest (if the dominant bit is the acknowledge) or later if the dominant bit is part of the message.

KNOWN LIMITATIONS (Cont'd)

Figure 3. Workaround 1 in Assembler

```
asm (
    spp #48          /* set CAN0_CTRL page          Bytes/cycles */
                    /* Use spp #36 for CAN1          2/4 */
    ld    r0, R244   /* For FIFO 0                  2/4 */
                    /* NB: Replace R244 with R245 for FIFO 1 */
    and   r0, #3     /*                               3/6 */
    cp    r0, #2     /*                               3/6 */
    jxnz  _release   /* (JRNE instruction)         2/6 */
                    /* if FMP is not 2 then FIFO */
                    /* release can be done */

    pushw RR232     /* push working group         2/8 or 10 */
    srp   #31       /* set group F as working group 2/4 */
_whileloop: btjfr1.5, _release /* REC bit of CMSR register 3/6 or 10 if jmp */
            btjfr12.3, _whileloop /* RX bit of CDGR register 3/6 or 10 if jmp */

_release:  or R244, #32 /* set RFOM bit of CRFR register 3/6 */
                    /* NB: Replace R244 with R245 for FIFO 1 */
    popw  RR232     /* restore previous working group 2/10 */
);
```

We can assume a time quantum number between 8 and 25. The worst case is when the baud rate prescaler is 0 (BRP=0) and the time quantum is 8, ie. TS1+TS2=5. This means a CPU frequency of 8MHz and 1 Mb/s for the CAN communication. In this case the minimum time between the end of the acknowledge and the critical period is 52 CPU cycles (48 for the 6 bit times + 4 for the (PROP SEG + T_{Seg 1})). According to the previous code timing, we need less than 22 cycles from the time we see the dominant state to the time we perform the FIFO release (one full loop + the actual release) therefore the application will never release the FIFO at the critical time when this workaround is implemented.

Timing analysis

- Time spent in the workaround

Inside a CAN frame, the longest period that the Rx pin stays in recessive state is 5 bits. At the end of the frame, the time between the acknowledge dominant bit and the end of reception (signaled by REC bit status) is 8T_{CANbit}, therefore the maximum time spent in the workaround is: 8T_{CANbit}+T_{loop}+T_{test}+T_{release} in this case or 8T_{CANbit}+68T_{CPU}.

At low speed, this time could represent a long delay for the application, therefore it makes sense to evaluate how frequently this delay occurs.

In order to reach the critical FMP=2, the CAN node needs to receive 2 messages without servicing them. Then in order to reach the critical window, the cell has to receive a third one and the application has to release the mailbox at the same time, at the end of the reception.

In the application, messages are not processed only if either the interrupt are disabled or higher level interrupts are being serviced.

Therefore if:

$$T_{IT \text{ higher level}} + T_{IT \text{ disable}} + T_{IT \text{ CAN}} < 2 \times T_{\text{CAN frame}}$$

the application will never wait in the workaround

T_{IT higher level}: This is the sum of the duration of all the interrupts with a level strictly higher than the CAN interrupt level

T_{IT disable}: This is the longest time the application disables the CAN interrupt (or all interrupts)

T_{IT CAN}: This is the maximum duration between the beginning of the CAN interrupt and the actual location of the workaround

KNOWN LIMITATIONS (Cont'd)

T_{CAN} frame: This is minimum CAN frame duration

Figure 4. Critical Window Timing Diagram

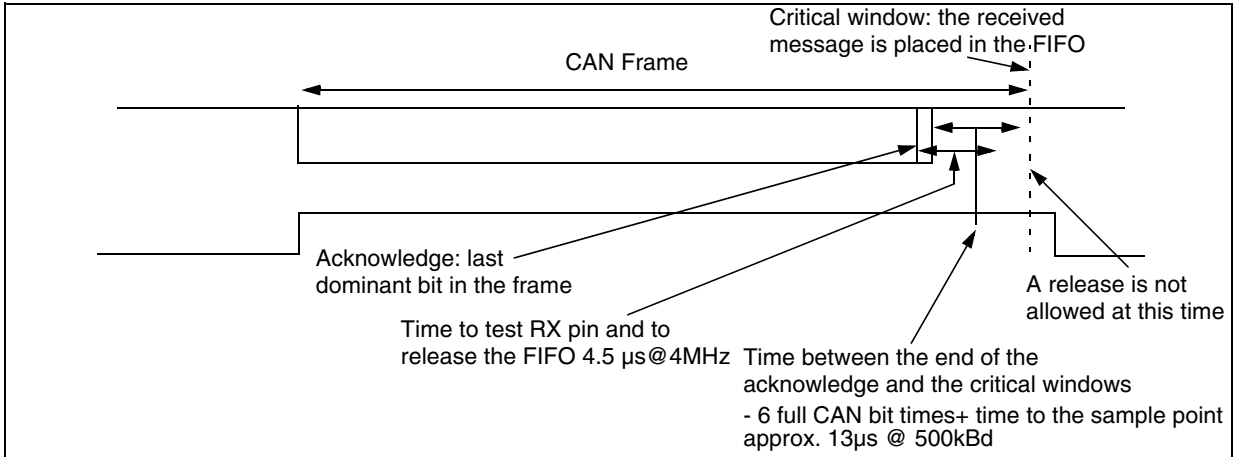
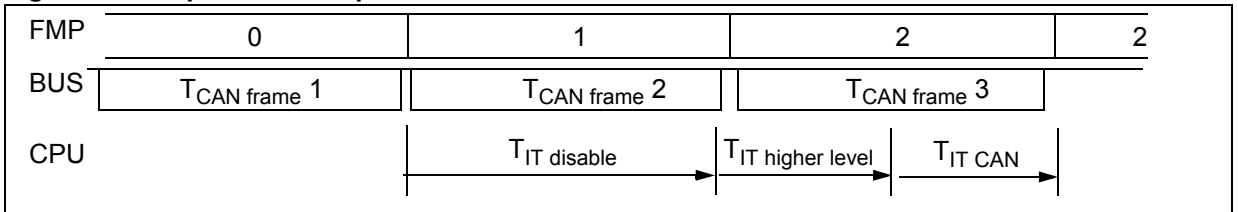

Figure 5. Reception of a Sequence of Frames



Side-effect of Workaround 1

Because the while loop lasts 16 CPU cycles, if $f_{CPU} \leq 16\text{MHz}$ at high baud rate, it is possible to miss a dominant state on the bus if it lasts just one CAN bit time and the bus speed is high enough (see Table 75)

Table 75. While Loop Timing

f_{CPU}	Baud rate for possible missed dominant bit
24 MHz	No dominant bit missed
16 MHz	1 MBaud
8 MHz	> 500 kHz
4 MHz	> 250 kHz
f_{CPU}	> $f_{CPU} / 16$

Note: As can be seen from the above table, no side effect occurs in cases when f_{CPU} is 16MHz or higher and if the CAN baud rate is below 1MBaud.

If this happens, we will continue waiting in the while loop instead of releasing the FIFO immediately. The workaround is still valid because we will not release the FIFO during the critical period. But the application may lose additional time waiting in the while loop as we are no longer able to guarantee a maximum of 6 CAN bit times spent in the workaround.

In this particular case the time the application can spend in the workaround may increase up to a full CAN frame, depending of the frame contents. This case is very rare but happens when a specific sequence is present on in the CAN frame.

The example in Figure 6 shows reception if T_{CAN} is $12/f_{CPU}$ and the sampling time is $16/f_{CPU}$.

If the application is using the maximum baud rate and the possible delay caused by the workaround is not acceptable, there is another workaround which reduces the Rx pin sampling time.

KNOWN LIMITATIONS (Cont'd)

Workaround 2

Workaround 2 (see [Figure 7](#)) first tests that FMP=2 and the CAN cell is receiving, if not the FIFO can be released immediately. If yes, the program goes through a sequence of test instructions on the RX pin that last longer than the time between the acknowledge dominant bit and the critical time slot. If the Rx pin is in recessive state for more than 8 CAN bit times, it means we are now

after the acknowledge and the critical slot. If a dominant bit is read on the bus, we can release the FIFO immediately. This workaround has to be written in assembly language to avoid the compiler optimizing the test sequence.

The implementation shown here is for the CAN bus maximum speed (1MBd @ 8MHz CPU clock).

Figure 6. Reception with TCAN=12/f_{CPU} and sampling time is 16/f_{CPU}

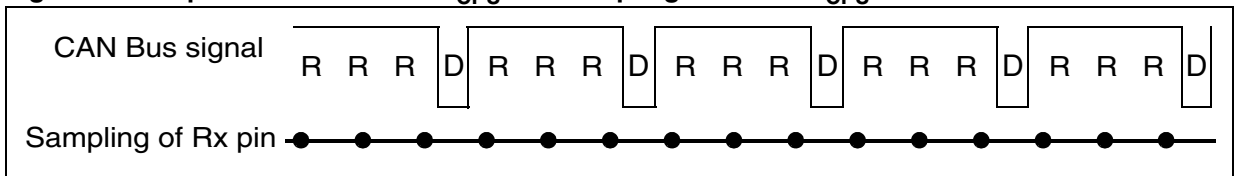

Figure 7. Workaround 2 in Assembler

```
asm ("
    spp #48                                /* set CAN0_CTRL page          Bytes/cycles */
                                           /* Use spp #36 for CAN1      2/4 */
    ld   r0, R244                          /* For FIFO 0                 2/4 */
                                           /* NB: Replace R244 with R245 for FIFO 1 */
    and  r0, #3                             /*                             3/6 */
    cp   r0, #2                             /*                             3/6 */
    jxnz _release                          /* (JRNE instruction)         2/6 */
                                           /* if FMP is not 2 then FIFO */
                                           /* release can be done      */

    pushw RR232                             /* push working group         2/8 or 10 */
    srp  #31                                /* set group F as working group 2/4 */
    btjf r1.5, _release                     /* REC bit of CMSR register   3/6 or 10 if jmp */

    btjf r12.3, _release                    /* sample RX bit for 8 bit time 3/6 or 10 if jmp */
    btjf r12.3, _release                    /* ie. 11 btjf instructions   3/6 or 10 if jmp */
    btjf r12.3, _release                    /*                             3/6 or 10 if jmp */
    btjf r12.3, _release                    /*                             3/6 or 10 if jmp */
    btjf r12.3, _release                    /*                             3/6 or 10 if jmp */
    btjf r12.3, _release                    /*                             3/6 or 10 if jmp */
    btjf r12.3, _release                    /*                             3/6 or 10 if jmp */
    btjf r12.3, _release                    /*                             3/6 or 10 if jmp */
    btjf r12.3, _release                    /*                             3/6 or 10 if jmp */
    btjf r12.3, _release                    /*                             3/6 or 10 if jmp */
    btjf r12.3, _release                    /*                             3/6 or 10 if jmp */
    btjf r12.3, _release                    /*                             3/6 or 10 if jmp */
    btjf r12.3, _release                    /*                             3/6 or 10 if jmp */

_release:  or R244, #32                    /* set RFOM bit of CRFR0 register 3/6 */
                                           /* NB: Replace R244 with R245 for FIFO 1 */
    popw  RR232                             /* restore previous working group 2/10 */
");
```

KNOWN LIMITATIONS (Cont'd)**13.7 MFT DMA MASK BIT RESET WHEN MFT0 DMA PRIORITY LEVEL IS SET TO 0****Introduction**

The MultiFunction Timer is a 16-bit timer with Input Capture and Output Compare modes. In Input Capture mode, the timer value is saved when an external event occurs. In Output Compare mode, the timer changes an I/O pin level when it reaches the Compare Register value.

In these two modes the event (Input Capture or Output Compare) may generate an interrupt or request a Direct Memory Access.

- In interrupt Input Capture mode (or Output Compare mode), the interrupt routine saves the counter in the RAM or the Register File (or updates the compare register from a location in RAM or in the Register File).
- In DMA mode these transfers are done automatically.

The choice between Interrupt or DMA modes is defined by the CP0D and CM0D bits (bit 6 and bit 3 in the IDMR register, R255 page 10/8).

CP0D : Capture 0 DMA Mask. Capture on REG0R DMA is enabled when CP0D = 1.

CM0D: Compare 0 DMA Mask. Compare on CMP0R DMA is enabled when CM0D = 1.

In DMA mode a DMA counter register and a DMA address register define the location and the size of

the memory block (RAM or Reg. File) involved in these transfers.

Each DMA transfer decreases the counter value. When the counter reaches 0, an EndOfBlock event occurs on the DMA controller. This event is detected by the MFT which resets the CP0D or the CM0D bit.

Limitation Description

The MFT1 resets its DMA Mask bit even if the End-of-Block signal is dedicated to the MFT0.

This limitation occurs if the following conditions are fulfilled:

- a MFT DMA request (for instance MFT1) occurs while another peripheral DMA request is being serviced (for instance MFT0),
- the MFT0 DMA request corresponds to an End-of-Block
- the MFT0 DMA priority level is set to 0.

This limitation is due to wrong End-of-Block event management by the MFT, it does not impact the SCI and the I2C but they can be involved in the limitation if:

- First peripheral requests a DMA transfer with End-of-Block event,
- Other peripherals request a DMA transfer with a higher priority level between the same two DMA arbitrations. As a consequence, the MFT1 DMA request is not serviced and a DMA transfer is lost. This is also true for a Top Level Interrupt (higher priority than DMA).

KNOWN LIMITATIONS (Cont'd)

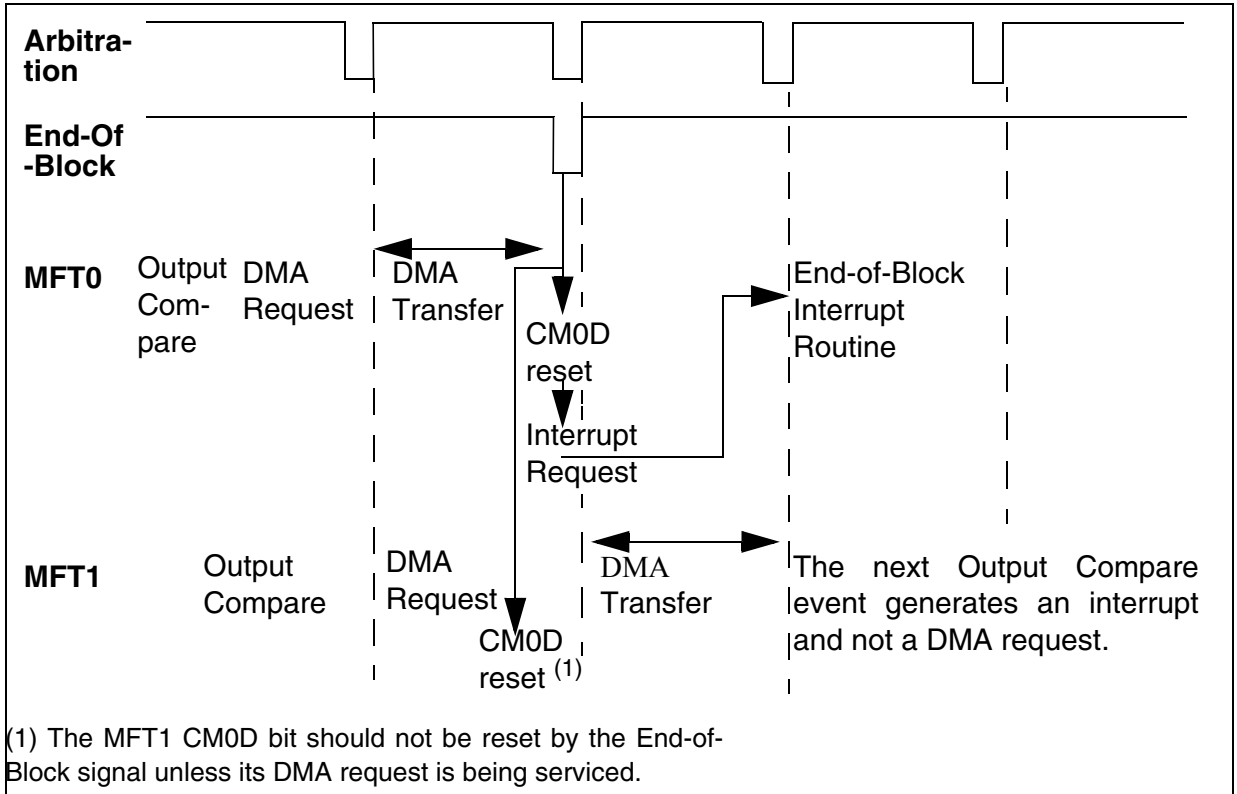

KNOWN LIMITATIONS (Cont'd)**Impact On Application**

1. The MFT1 wins the next DMA Arbitration, the DMA request is serviced.
The MFT0 interrupt routine is executed before the next Input Capture or Output Compare event. It detects that a wrong Mask Bit Reset has occurred on the MFT1 and re-enables the DMA Mask.
=> There is no application impact.
2. The MFT1 does not win the next DMA Arbitration, the DMA request is not serviced. The MFT1 will not request the DMA again as its DMA Mask bit is reset.
=> A DMA transfer is lost.

The MFT0 interrupt routine is executed before the next Input Capture or Output Compare event. It detects that a wrong Mask Bit Reset has occurred on the MFT1 and re-enables the DMA Mask.
=> An Input Capture value is lost or a Compare value is used twice.
3. The MFT1 wins the next DMA Arbitration, the DMA request is serviced.
The MFT0 interrupt routine is not executed before the next MFT1 Input Capture or Output Compare event. This new event generates an Interrupt. The interrupt routine must check that the DMA counter is equal to 0. If it is not equal to 0, the DMA counter and address must not be changed, but the DMA Mask must be set.
=> An Input Capture value or a Comparison value must be handled by the interrupt routine.

If this failure recovery management can be executed fast enough within the interrupt routine, there is no impact on the application. Otherwise the counter will reach the new compare value before it has been loaded in the Compare Register or a new input capture event will occur before the previous value has been saved.

4. The MFT1 does not win the next DMA Arbitration, the DMA request is not serviced. The MFT1 will not request the DMA again as its DMA Mask bit is reset.

=> A DMA transfer is lost.

The MFT0 interrupt routine is not executed before the next MFT1 Input Capture or Output Compare event. This new event generates an Interrupt. The interrupt routine must check that the DMA counter is equal to 0. If it is not equal to 0, the DMA counter and address must not be changed, but the DMA Mask must be set.

=> An Input Capture value or a Comparison value must be handled by the interrupt routine.

If this failure recovery management can be executed fast enough within the interrupt routine, only one transfer is lost. Otherwise the counter will reach the new compare value before it has been loaded in the Compare Register or a new input capture event will occur before the previous value has been saved.

Workaround

If it is not possible to limit the DMA to one MFT only (no DMA with another MFT, SCI-M or I2C), the following failure recovery management must be included in the MFT, SCI-M, I2C Interrupt routines (if the DMA is used).

1. Following an End-of-Block event (DMA counter equal to 0):
Check the other MFT DMA counter (both MFTs if this is the SCI-M or the I2C interrupt routine). If the counter does not equal 0 and the DMA mask is reset, reset the interrupt flag bit, set the DMA Mask bit.
2. Following an Input Capture or an Output Compare event (DMA counter does not equal 0):
Execute the transfer by software, modify the DMA counter and address, reset the interrupt flag bit, set the DMA Mask bit.

KNOWN LIMITATIONS (Cont'd)

Here is an example of a patch for the MFT1 using DMA in output compare mode, inserted at the beginning of the MFT0 interrupt routine:

```
spp #8 ;Set to page 8 (mft1)
tm T_IDMR,#0x08 ;test mft0 OCMP dma
mask bit
jxnz MFT0_it_routine
cpw DMA_CNT1,#0 ;If the DMA count is
not at zero the block did not complete
jxeq MFT0_it_routine
and T_FLAGR,#11011111b ;Clear dma
compare interrupt request
```

```
or T_IDMR,#0x08 ;Re-enable the com-
pare 0 dma
```

```
MFT0_it_routine: ;MFT0 interrupt rou-
tine code
```

In addition, the peripheral DMA priorities must be organized so that the MFT DMA priorities are the highest. This way the impact is limited: DMA requests with the wrong Mask Bit Reset are serviced.

Workaround Limitation

If the counter event period is too short, the failure recovery in the interrupt routines will not work.

KNOWN LIMITATIONS (Cont'd)

13.8 EMULATION CHIP LIMITATIONS

Additional limitations exist on Emulation chips (EMU2 emulator). These limitations correspond to those present in AxxxxxxxY trace codes (ST92F150). They are listed in the following table.

Section	Limitation (AxxxxxxxY trace code)
Section 13.8.1	RESET BEHAVIOUR FOR BI-DIRECTIONAL, WEAK PULL-UP PORTS
Section 13.8.2	HIGH DRIVE I/Os WHEN BSZ=1
Section 13.8.3	ADC PARASITIC DIODE
Section 13.8.4	ADC ACCURACY VS. NEGATIVE INJECTION CURRENT
Section 13.8.5	I2CECCR REGISTER LIMITATION
Section 13.8.6	I2C BEHAVIOUR DISTURBED DURING DMA TRANSACTIONS
Section 13.8.7	MFT DMA MASK BIT RESET
Section 13.8.8	DMA DATA CORRUPTED BY MFT INPUT CAPTURE
Section 13.8.9	SCI-A WRONG BREAK DURATION
Section 13.8.10	LIN MASTER MODE NOT PRESENT ON SCI-A
Section 13.8.11	LIMITATIONS ON LQFP64 PACKAGES

13.8.1 RESET BEHAVIOUR FOR BI-DIRECTIONAL, WEAK PULL-UP PORTS

This section applies to ports P1[7:3], P4[1], P8[7:2] and P9[7:0].

During the reset phase (external reset signal low) and the delay of 20400 clock periods (t_{RSPH}) following a reset, these ports are in High Impedance state, while according to the datasheet they should

have weak pull-ups. These ports then enter Weak Pull-up state until the user overwrites the reset values of I/O Port Control Registers PxC0, PxC1 and PxC2.

Table 76. Reset Behaviour Table

Port	Datasheet Condition	Rev Z Behaviour					
		Port Behaviour			Control Register Value		
		While $\overline{\text{RESET}}$ is low	During next 20K Clock Cycles	After these 20K Clock Cycles	PxC0	PxC1	PxC2
P1[7:3]	Bi-Dir + WPU	Hi-Z	Hi-Z	Bi-Dir + WPU	0	0	0
P4.1	Bi-Dir + WPU	Hi-Z	Hi-Z	Bi-Dir + WPU	0	0	0
P8[7:2]	Bi-Dir + WPU	Hi-Z	Hi-Z	Bi-Dir + WPU	0	0	0
P9[7:0]	Bi-Dir + WPU	Hi-Z	Hi-Z	Bi-Dir + WPU	0	0	0

Shaded areas represent erroneous operations.

KNOWN LIMITATIONS (Cont'd)

During reset, the risk of power consumption in the input stage due to floating inputs is avoided by a design feature.

However, if the application requires pull-ups during reset (for instance, in order to send known logic values to external devices), external pull-ups must be provided. When the I/O port outputs a zero, there will be some additional power consumption as these external pull-ups are not switched off.

These ports behave in the same way following an external, watchdog or software reset.

13.8.2 High Drive I/Os when BSZ=1

Description

If the BSZ bit in the EMR1 register (bit 1 of R245, page 21) is set so as to use high-drive output buffers for P4[7:6] and P6[5:4], all I/O ports as well as \overline{AS} , \overline{DS} and \overline{RW} will also use high-drive output buffers.

Impact On Application

P0[7:0], \overline{AS} , \overline{DS} and \overline{RW} have the same V_{OH} parameter value as P6[5:4].

P0[7:0]-P2[3:2], \overline{AS} , \overline{DS} and \overline{RW} have the same V_{OL} and I_{IO} parameter values as the P4[7:6] and P6[5:4].

These I/Os using high-drive output buffers will generate more noise than those using the standard low-noise output buffers.

13.8.3 ADC PARASITIC DIODE

Description

A parasitic diode is present between an ADC input and AV_{DD} .

As described in the datasheet, the user has the possibility to switch off AV_{DD} when he switches off the ADC to save power consumption. However, if AV_{DD} is connected to ground and a voltage is present on the Input Port, an increase in power consumption can occur.

The Input Port affected by this diode is the one pointed to by the analog multiplexer of the ADC, if the port is set up as AF analog input. When the ADC is stopped, the multiplexer points to the first input to be converted in a scan (i.e. the channel pointed to by the SC[3:0] bits).

Workaround

In order to avoid this problem, the I/O connected to the ADC has to be set up in any mode except AF analog input (i.e. any combination of PxC2.. PxC0 except 111).

1. Deprogram analog input mode from the I/O port which is pointed to by the SC[3:0] bits (start conversion channel, b7..b4 of CLR1).

For example the I/O can be reprogrammed as an open drain output, with the data at 1. The high impedance of the output stage then avoids a conflict with the external voltage source. In order to avoid potential power consumption in the input buffer of this I/O, depending on the external voltage applied to the pin, it is wise to set the 'start conversion channel' to a channel which carries levels below 800 mV or above ($V_{DD} - 800$ mV).

Another possibility is to modify the SC[3:0] bits so that they point to an I/O Port which is not used as an analog input.

2. Next, switch off the A/D Converter.

The current in AV_{DD} will be zero, whatever the logic levels on the analog inputs, and whatever the voltage level applied to AV_{DD} (between 0 and V_{DD}).

13.8.4 ADC ACCURACY VS. NEGATIVE INJECTION CURRENT

Description

If a negative current is injected to an input pin (i.e. input signal voltage below -0.3V), a part of this current will be drawn from the adjacent I/Os. The following curve quantifies this current:

KNOWN LIMITATIONS (Cont'd)

Figure 8. Impact of negative current injection on adjacent pin

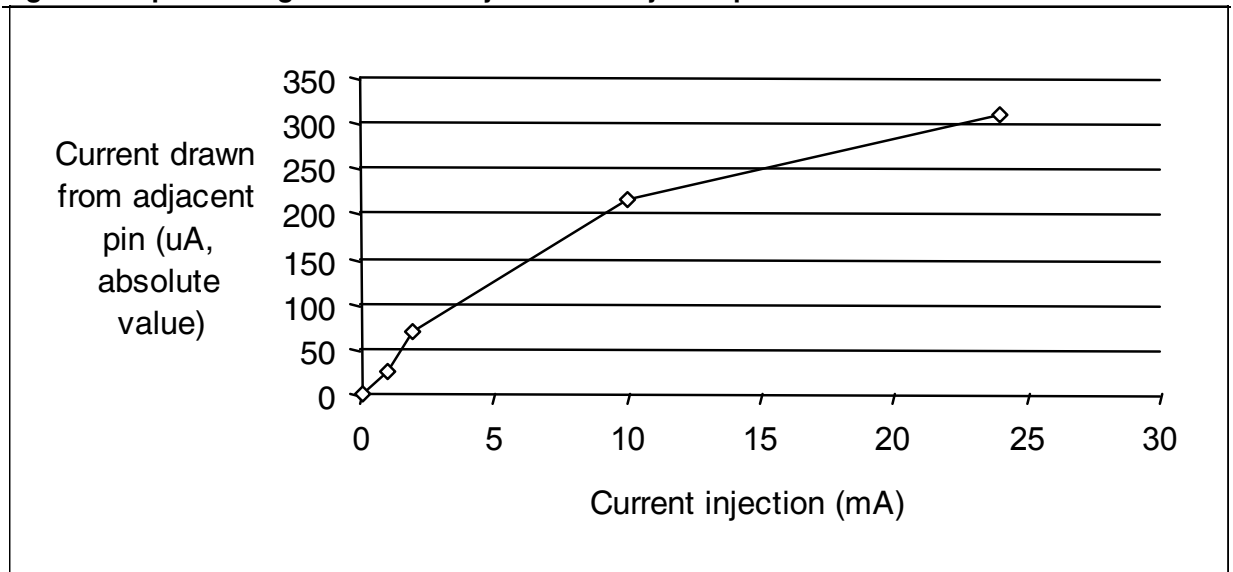
**Impact on application**

If the adjacent I/O is used as an analog input (Port 7 and 8 only), the current drawn through the external resistor generates a difference in potential, resulting in a conversion error.

13.8.5 I2CECCR REGISTER LIMITATION

It is not possible to write to the CC7 and CC8 bits in the I2CECCR register. These bits remain at their reset value (0).

Impact on application

The baudrate prescaler cannot be higher than 258 (CC8:7=0 and CC6:0=1). As a consequence, the baudrate cannot be lower than $f_{SCL} = INTCLK/258$

Workaround

None.

13.8.6 I2C BEHAVIOUR DISTURBED DURING DMA TRANSACTIONS**Description**

If a DMA transfer occurs on SCI-M, MFT or J1850 during I2C transmission or reception, I2C peripheral may be disturbed.

In transmission mode, additional bytes can be observed on I2C lines (SDA and SCL). In reception

mode, additional bytes can be seen in the I2CDR register.

Workaround

Avoid using DMA transfer while I2C peripheral is running.

13.8.7 MFT DMA MASK BIT RESET

The limitation described in [Section 13.7 on page 419](#) applies whatever the MFT0 DMA priority level.

13.8.8 DMA DATA CORRUPTED BY MFT INPUT CAPTURE**Description**

If the MFT requests a DMA transfer following an input capture event and while a DMA transfer is currently ongoing to or from another peripheral (SCI-M, I2C, or second MFT), the DMA data is corrupted (overwritten by the captured data).

Workaround

Avoid using the MFT Input Capture function in DMA mode while another peripheral is in DMA mode.

13.8.9 SCI-A wrong break duration

Description

A single break character is sent by setting and re-setting the SBK bit in the SCICR2 register. In some cases, the break character may have a longer duration than expected:

- 20 bits instead of 10 bits if M=0
- 22 bits instead of 11 bits if M=1.

In the same way, as long as the SBK bit is set, break characters are sent to the TDO pin. This may lead to generate one break more than expected.

Occurrence

The occurrence of the problem is random and proportional to the baudrate. With a transmit frequency of 19200 baud ($f_{CPU}=8\text{MHz}$ and $SCIBRR=0xC9$), the wrong break duration occurrence is around 1%.

Workaround

If this wrong duration is not compliant with the communication protocol in the application, software can request that an Idle line be generated before the break character. In this case, the break duration is always correct assuming the application is not doing anything between the idle and the break. This can be ensured by temporarily disabling interrupts.

The exact sequence is:

- Disable interrupts
- Reset and Set TE (IDLE request)
- Set and Reset SBK (Break Request)
- Re-enable interrupts

LIN mode (if available)

If the LINE bit in the SCICR3 is set and the M bit in the SCICR1 register is reset, the SCI-A is in LIN master mode. A single break character is sent by setting and resetting the SBK bit in the SCICR2 register. In some cases, the break character may have a longer duration than expected:

- 24 bits instead of 13 bits

KNOWN LIMITATIONS (Cont'd)**Occurrence**

The occurrence of the problem is random and proportional to the baudrate. With a transmit frequency of 19200 baud (fCPU=8MHz and SCIBRR=0xC9), the wrong break duration occurrence is around 1%.

Analysis

The LIN protocol specifies a minimum of 13 bits for the break duration, but there is no maximum value. Nevertheless, the maximum length of the header is specified as $(14+10+10+1) \times 1.4 = 49$ bits. This is composed of:

- the synch break field (14 bits),
- the synch field (10 bits),
- the identifier field (10 bits).

Every LIN frame starts with a break character. Adding an idle character increases the length of each header by 10 bits. When the problem occurs, the header length is increased by 11 bits and becomes $((14+11)+10+10+1) = 45$ bits.

To conclude, the problem is not always critical for LIN communication if the software keeps the time

between the synch field and the ID smaller than 4 bits, i.e. 208us at 19200 baud.

The workaround is the same as for SCI mode but considering the low probability of occurrence (1%), it may be better to keep the break generation sequence as it is.

13.8.10 LIN MASTER MODE NOT AVAILABLE ON SCI-A

LIN Synch Breaks (13 low bits) generation is not possible on SCI-A. LINE bit has no effect on break length.

13.8.11 LIMITATIONS ON LQFP64 DEVICES**13.8.11.1 AIN[7:0] NOT AVAILABLE ON LQFP64 DEVICES**

ADC Channels from AIN0 to AIN7 are not present on LQFP64 devices.

13.8.11.2 EFT0 AND EFT1 NOT AVAILABLE ON LQFP64 DEVICES

Extended Function Timers are not present on LQFP64 devices.

14 REVISION HISTORY

Table 77. Revision History

Date	Revision	Main Changes
28-Oct-2004	3	Revision number incremented from 1.5 to 3.0 due to Internal Document Management System change Changed document status: Datasheet instead of Preliminary Data Added 2EFT for TQFP64 devices Changed description in Section 1.2.2 on page 11 Replaced 1 by DPR1 in Page 21 column (Figure 26 on page 43) Removed references to sector 2 (mirrored) in Figure 30 on page 50 , Table 7 on page 52 . and Figure 41 on page 71 Removed formula in the description of I2CCCR on page 277 and added Table 70 on page 399 . Removed “mask option” in the description of ETO bit on page 148 Changed “INTCLK range” table (FREQ[2:0] bits) on page 278 Replaced RX by REC and TX by TRAN in CMSR register on page 344 Changed Section 10.11 on page 362 (added divider/2) and Table 69 on page 372 . Changed “FLASH / E3 TM SPECIFICATIONS” on page 381 Changed I _O values in “DC ELECTRICAL CHARACTERISTICS” on page 377 Added Table , “BOOTROM TIMING TABLE,” on page 385 Changed ACD Accuracy table on page 402 Changed Table 73 on page 407 . Added Section 13 on page 408
19-Nov-2004	4	Changed Table 69 on page 372 .
16-Nov-2006	5	Replaced TQFP by LQFP Modified reset state and WPU columns for Port 1[7:3] in Table 3 on page 24 Modified silicon revision list in Section 13 on page 408 Added Table 74 on page 408 Added Section 13.7 on page 419 Removed P1 I/O port characteristics section in “EMULATION CHIP LIMITATIONS” on page 423 : limitation now described in Section 13.8.1 on page 423 and changed according to modifications made to Table 3 on page 24 . Added two part numbers: ST92F124R1C6 (128K/LQFP64) and ST92F124V1Q6 (128K/LQFP100)
01-Dec-2008	6	Added “SOLDERING AND GLUEABILITY INFORMATION” on page 406

Please Read Carefully:

Information in this document is provided solely in connection with ST products. STMicroelectronics NV and its subsidiaries ("ST") reserve the right to make changes, corrections, modifications or improvements, to this document, and the products and services described herein at any time, without notice.

All ST products are sold pursuant to ST's terms and conditions of sale.

Purchasers are solely responsible for the choice, selection and use of the ST products and services described herein, and ST assumes no liability whatsoever relating to the choice, selection or use of the ST products and services described herein.

No license, express or implied, by estoppel or otherwise, to any intellectual property rights is granted under this document. If any part of this document refers to any third party products or services it shall not be deemed a license grant by ST for the use of such third party products or services, or any intellectual property contained therein or considered as a warranty covering the use in any manner whatsoever of such third party products or services or any intellectual property contained therein.

UNLESS OTHERWISE SET FORTH IN ST'S TERMS AND CONDITIONS OF SALE ST DISCLAIMS ANY EXPRESS OR IMPLIED WARRANTY WITH RESPECT TO THE USE AND/OR SALE OF ST PRODUCTS INCLUDING WITHOUT LIMITATION IMPLIED WARRANTIES OF MERCHANTABILITY, FITNESS FOR A PARTICULAR PURPOSE (AND THEIR EQUIVALENTS UNDER THE LAWS OF ANY JURISDICTION), OR INFRINGEMENT OF ANY PATENT, COPYRIGHT OR OTHER INTELLECTUAL PROPERTY RIGHT.

UNLESS EXPRESSLY APPROVED IN WRITING BY AN AUTHORIZED ST REPRESENTATIVE, ST PRODUCTS ARE NOT RECOMMENDED, AUTHORIZED OR WARRANTED FOR USE IN MILITARY, AIR CRAFT, SPACE, LIFE SAVING, OR LIFE SUSTAINING APPLICATIONS, NOR IN PRODUCTS OR SYSTEMS WHERE FAILURE OR MALFUNCTION MAY RESULT IN PERSONAL INJURY, DEATH, OR SEVERE PROPERTY OR ENVIRONMENTAL DAMAGE. ST PRODUCTS WHICH ARE NOT SPECIFIED AS "AUTOMOTIVE GRADE" MAY ONLY BE USED IN AUTOMOTIVE APPLICATIONS AT USER'S OWN RISK.

Resale of ST products with provisions different from the statements and/or technical features set forth in this document shall immediately void any warranty granted by ST for the ST product or service described herein and shall not create or extend in any manner whatsoever, any liability of ST.

ST and the ST logo are trademarks or registered trademarks of ST in various countries.

Information in this document supersedes and replaces all information previously supplied.

The ST logo is a registered trademark of STMicroelectronics. All other names are the property of their respective owners.

© 2008 STMicroelectronics - All rights reserved

STMicroelectronics group of companies

Australia - Belgium - Brazil - Canada - China - Czech Republic - Finland - France - Germany - Hong Kong - India - Israel - Italy - Japan - Malaysia - Malta - Morocco - Singapore - Spain - Sweden - Switzerland - United Kingdom - United States of America

www.st.com