

6

5

4

3

2

1

APPROVED: _____

DATE: _____ TITLE: _____

Rev	AWO #	Description	Date	Appr
-		RELEASED	3/11/20	

D

D

C

C

B

B

A

A

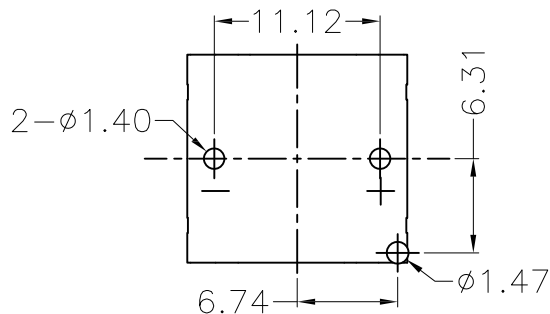
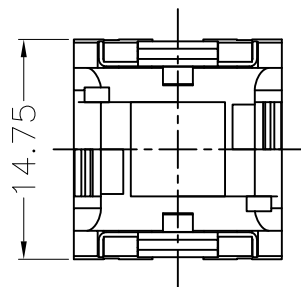

RECOMMENDED PCB LAYOUT

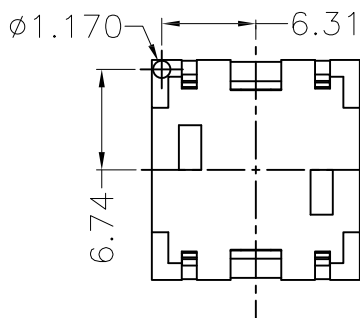
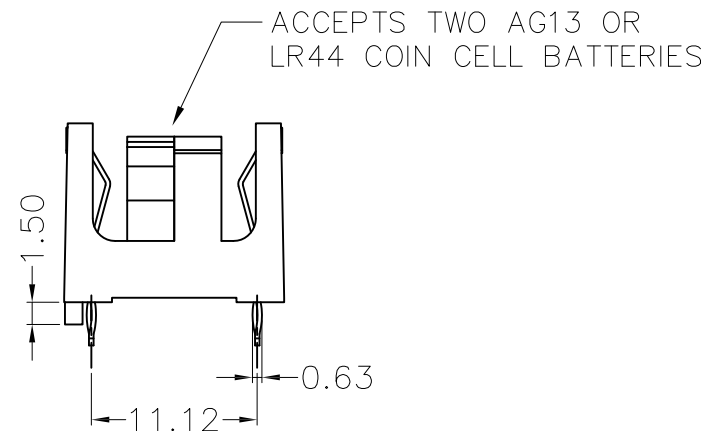
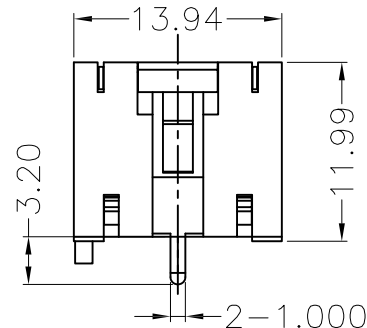

PART NO.	MATERIAL
BH-82-1-1A	PBT, BLACK
BH-82-1-1B	PA66, BLACK
BH-82-1-2A	PPA, BROWN
BH-82-1-2B	PPA, BLACK
BH-82-1-3A	PPS, BROWN
BH-82-1-3B	PPS, BLACK
BH-82-1-4A	LCP, WHITE
BH-82-1-4B	LCP, BLACK

SPECIFICATIONS:

- Material:
- Housing: (See chart)
- Housing Color: (See chart)
- Contact: Phosphor Bronze
- Plating:
- Gold flash over Nickel underplate overall
- Electrical:
- Contact resistance: 30 Milliohms max
- Insulation resistance: 1,000 Megaohms ohms min
- Dielectric Voltage: 500 VAC one sec level
- Temperature Rating:
- Operating temperature: -25°C to +85°C.
- Environmental:
- Lead free, RoHS compliant



UNLESS OTHERWISE SPECIFIED
 ALL DIMENSIONS ARE MILLIMETERS
 TOLERANCES: EXCEPT AS NOTED

MM	ANGLE
X ± 0.30	X ± 1°
X.X ± 0.25	X.X ± 0.5°
X.XX ± 0.20	
X.XXX ± 0.10	

ADAM TECH
 INTERCONNECTS
 909 Rahway Avenue,
 Union, NJ 07083
 Phone: 908-687-5000
 Fax: 908-687-5710

APPROVALS		DATE
DRAWN	LH	3/11/20
CHECKED	OC	3/11/20
APPROVED		

TITLE		
BATTERY HOLDER, DIP TYPE, FOR TWO AG13 / LR44 COIN CELL		
SIZE	PART NO.	REV.
X	BH-82-1-XX	-
REF: S00138C	SCALE: NTS	SHEET 1 OF 1

6

5

4

3

2

1