

THIS DRAWING IS UNPUBLISHED. RELEASED FOR PUBLICATION
 © COPYRIGHT - By - ALL RIGHTS RESERVED.

LOC	DIST	REVISIONS			
P	LTR	DESCRIPTION	DATE	DWN	APVD
AF	50	AS2	REVISED PER ECR-19-018151	12NOV2020	AA EW

- 1 CONTINUOUS STRIP ON REELS.
- 2 PART TO BE PUT ON PLASTIC REELS.
- 3 FINISH LEAD-FREE, MATTE TIN OVER NICKEL

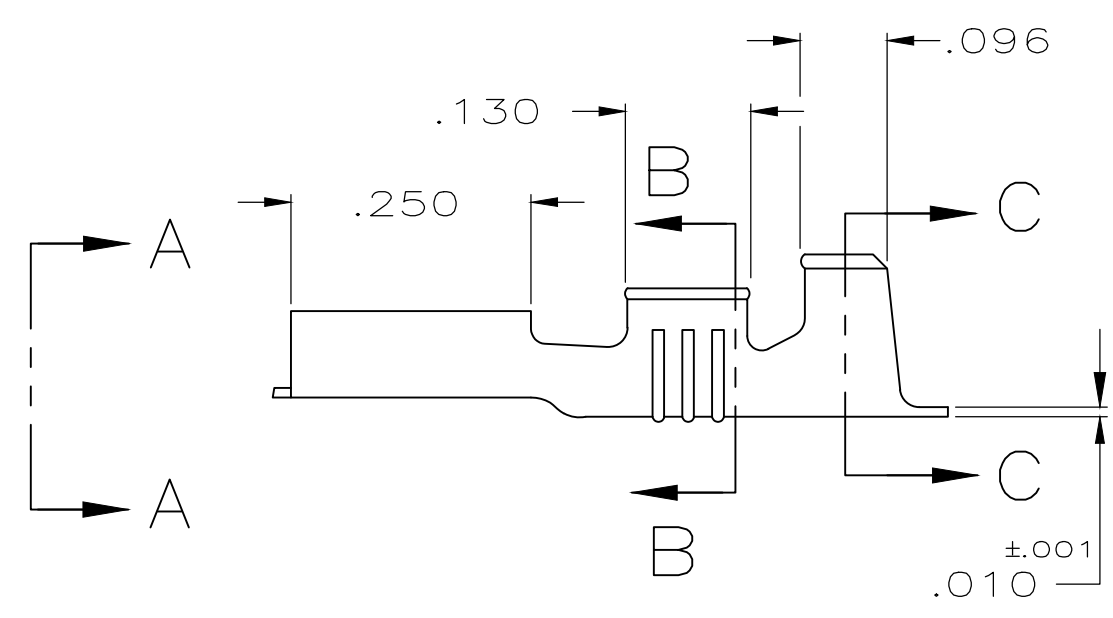
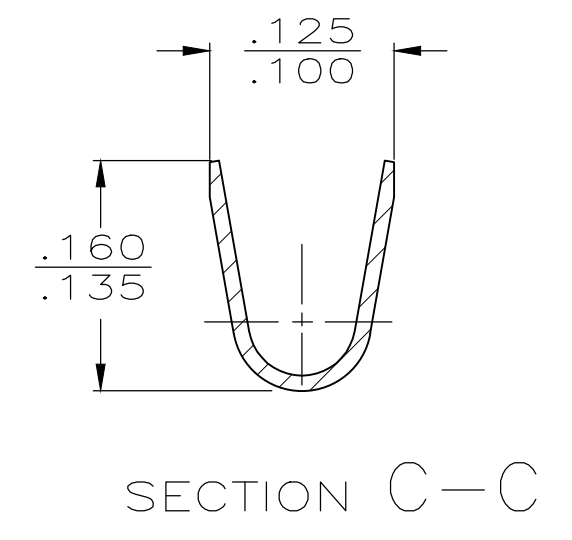
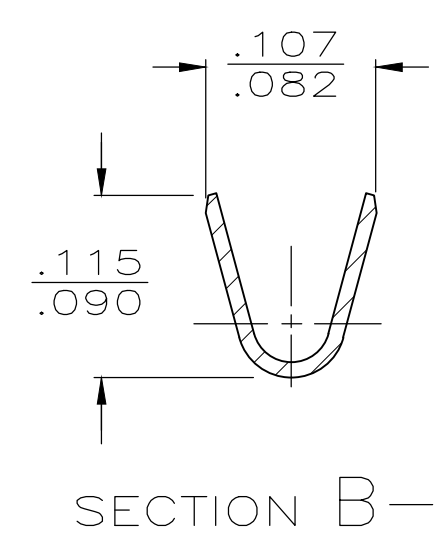
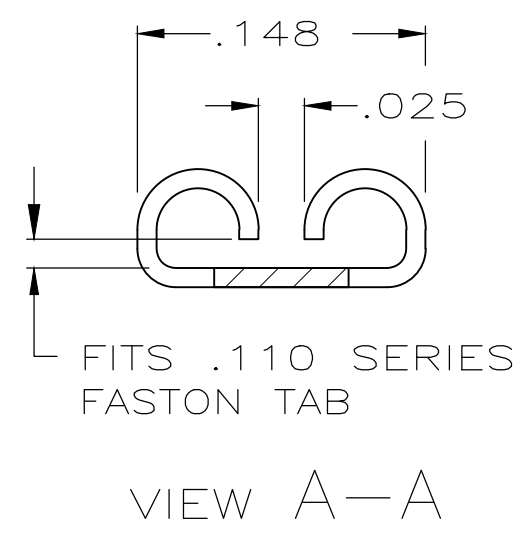
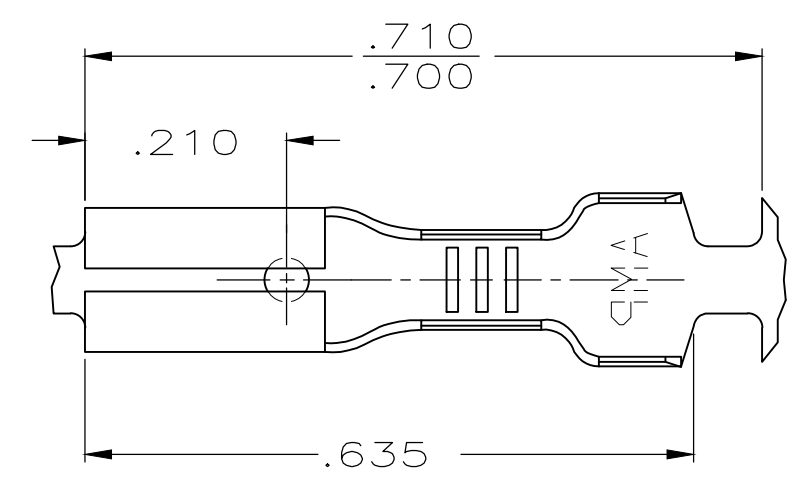

OBSOLETE	3	BRASS	.060-.100	22-18	.016	60118-5	
	PRE-TIN	BRASS				60118-4/2	
OBSOLETE		SILVER	.060-.100	22-18	.016	60118-2	
		#4H PHOS BRZ				60118-1	
		PRE-TIN					
		BRASS					
		FINISH	MATERIAL	INSUL RANGE	WIRE SIZE	MATING TAB THK	PART NUMBER

THIS DRAWING IS A CONTROLLED DOCUMENT.		DWN JR RUTH 6/23/87	STE TE Connectivity			
DIMENSIONS: INCHES		CHK G YETTER 6/23/87				
TOLERANCES UNLESS OTHERWISE SPECIFIED:		APVD C MEYERS 6/23/87	NAME RECEPTACLE, FASTON,™ .110 SERIES			
0 PLC ± -		PRODUCT SPEC	SIZE CAGE CODE DRAWING NO RESTRICTED TO			
1 PLC ± -		APPLICATION SPEC	A3 00779 C-60118			
2 PLC ± -		WEIGHT	SCALE NTS SHEET 1 OF 1 REV AS2			
3 PLC ± .015						
4 PLC ± -						
ANGLES ± -						
MATERIAL SEE TABLE		FINISH SEE TABLE				