

TRANSFORMER, POWER, PCB 6.0VA
 SINGLE 115V PRIMARY AND DUAL SECONDARIES

1. ELECTRICAL SPECIFICATIONS:

- A. Maximum Power: 6.0 VA
- B. Input Voltage and Frequency: 115V± 10% @ 50/60Hz
- C. Secondary Voltage: See Electrical Table
- D. Temperature Rise: 45° C MAX allowed
- E. Excitation Current: 45 mA MAX
- F. Hi-Pot: 2500Vrms 1 minute @ Pri. to Sec.
 1500Vrms 1 minute @ Pri. to Core
 1500Vrms 1 minute @ Sec. to Core
- G. Safety:

Insulation System ZM-130-5, Class B, UL File No.E177235
 UL506, General Purpose, US and Canada, File No.E177998

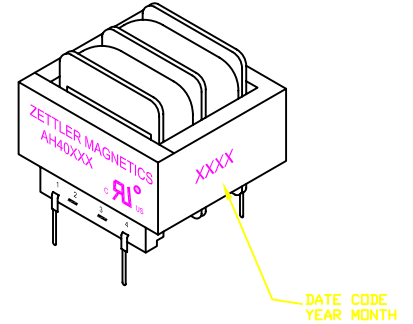

2. MECHANICAL SPECIFICATIONS:

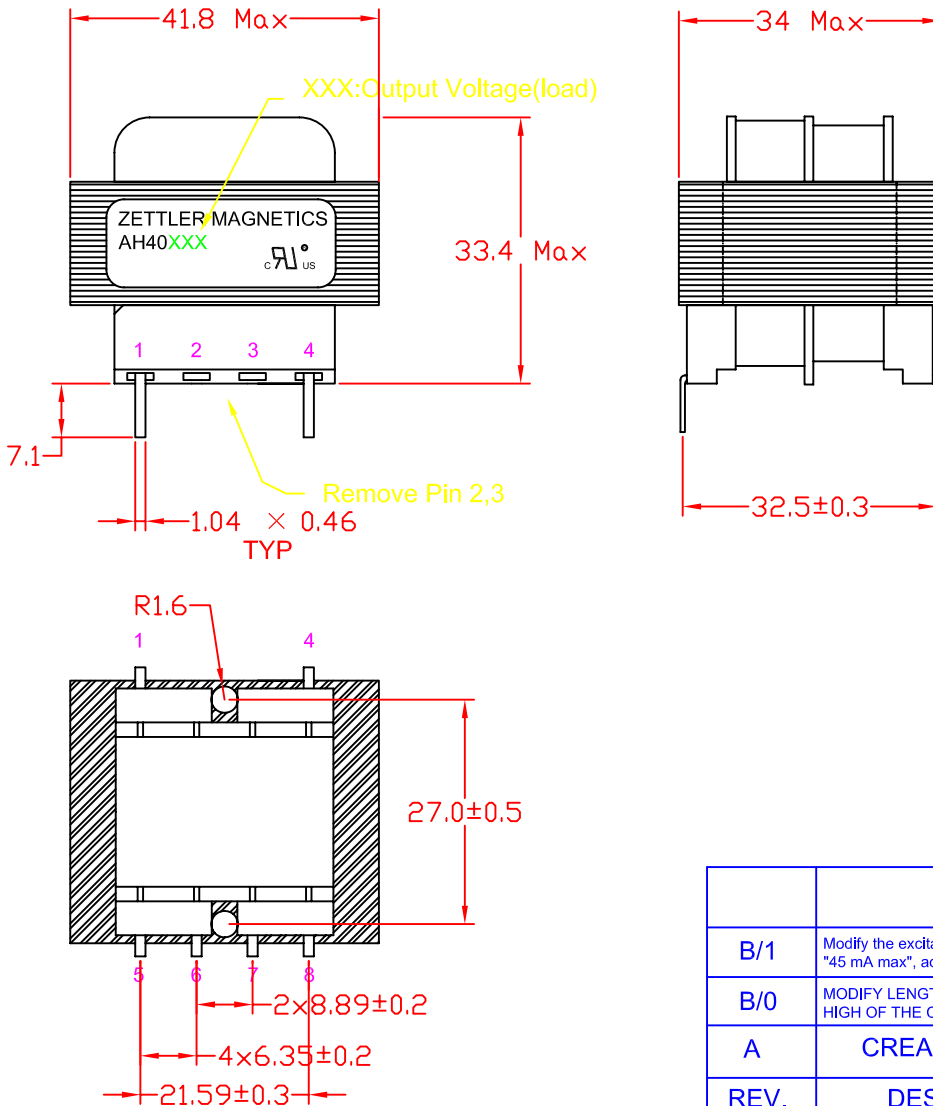

REV.	DESCRIPTION	DRAWN	DATE(M/D/Y)
B/1	Modify the excitation current "30mA Max" to "45 mA max", add some tolerance.	ye	Apr 17,2007
B/0	MODIFY LENGTHS OF THE PIN,ADD THE HIGH OF THE CENTER BOBBIN WALL	ye	June 12,2006
A	CREATED DRAWING	ZHENG	June 17,2002

TOLERANCE	SCALE NOT 1:1	UNIT mm	DATE (M/D/Y)
X	±0.3	DRAWN	ye
X.X	±0.2	CHECKED	
X.XX	±0.1	QC	
THICKNESS	/	APPROVED	
REV.	B/1		

MODEL DESCRIPTION	
ZETTLER MAGNETICS	MATERIAL Class B 130° C
TITLE AH400 SERIES PCD	MODEL: AH400 SERIES
	SHEET: 1 OF 2

3. MOUNTING FOOTPRINT:

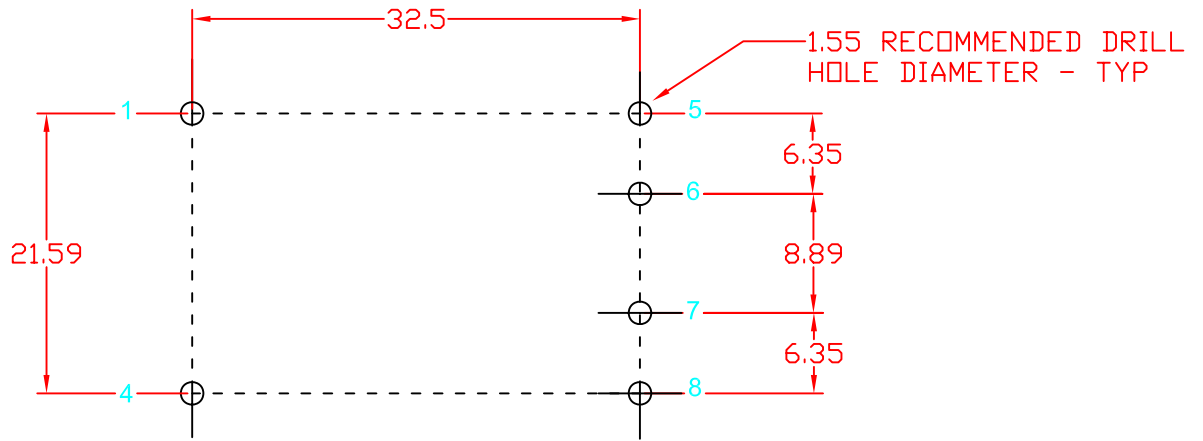

4. SCHEMATIC DIAGRAM:

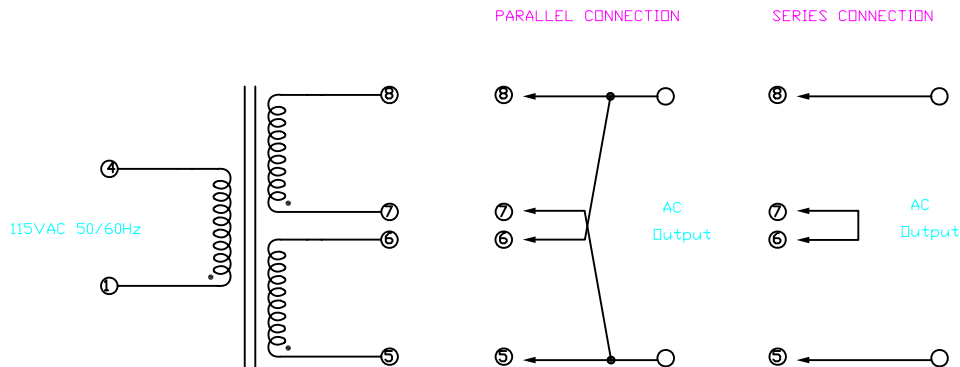

5. ELECTRICAL TABLE:

PART NO.	PARALLEL CONNECTION		SERIES CONNECTION	
	AC VOLTAGE	CURRENT	AC VOLTAGE	CURRENT
AH40010	5V	1.2A	10V	0.6A
AH40012	6.3V	1.0A	12.6V	0.5A
AH40016	8V	0.8A	16V	0.4A
AH40020	10V	0.6A	20V	0.3A
AH40024	12V	0.5A	24V	0.25A
AH40028	14V	0.4A	28V	0.2A
AH40036	18V	0.34A	36V	0.17A
AH40048	24V	0.25A	48V	0.125A
AH40056	28V	0.22A	56V	0.11A
AH40120	60V	0.1A	120V	0.05A

B/1	Modify the excitation current "30mA Max" to "45 mA max", add some tolerance.	ye	Apr 17,2007
B/0	MODIFY LENGTHS OF THE PIN,ADD THE HIGH OF THE CENTER BOBBIN WALL	ye	June 12,2006
A	CREATED DRAWING	ZHENG	June 17,2002
REV.	DESCRIPTION	DRAWN	DATE(M/D/Y)

TOLERANCE		SCALE NOT 1:1	UNIT mm	DATE (M/D/Y)	MODEL DESCRIPTION	
X	±0.3	DRAWN	ye	Apr 17,2007	ZETTLER MAGNETICS	MATERIAL Class B 130° C
X.X	±0.2	CHECKED				MODEL: AH400 SERIES
X.XX	±0.1	QC				
THICKNESS	/	APPROVED				
REV.	B/1				TITLE AH400 SERIES PCD	SHEET: 2 OF 2