

VND5T100AJ-E Evaluation board

Data brief

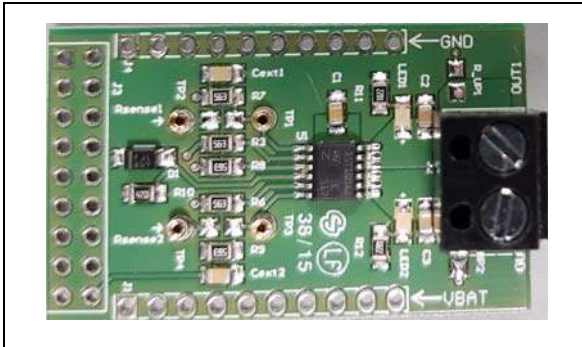

Features

Parameter	Symbol	Value	Unit
Max transient supply voltage	V_{CC}	58	V
Operating voltage range	V_{CC}	8 to 36	V
Typ.on-state resistance	R_{ON}	35	m Ω
Current limitation (typ)	I_{LIMH}	42	A
Off state supply current	I_s	2	μA ⁽¹⁾

1. Typical value with all loads connected

- General device features
 - Very low standby current
 - 3.0 V CMOS compatible input
 - Optimized electromagnetic emission
 - Very low electromagnetic susceptibility
 - Compliant with 2002/95/EC European directive
 - Fault reset standby pin (FR_Stby)
- Diagnostic functions
 - Proportional load current sense
 - Current sense precision for wide range currents

- Off-state open-load detection
- Output short to V_{CC} detection
- Overload and short to ground latch-off
- Thermal shutdown latch-off
- Very low current sense leakage
- Protection
 - Undervoltage shutdown
 - Overvoltage clamp
 - Load current limitation
 - Self limiting of fast thermal transients
 - Protection against loss of ground and loss of V_{CC}
 - Thermal shutdown
 - Reverse battery protected with self switch of the PowerMOS
 - Electrostatic discharge protection

Applications

- All types of Automotive resistive, inductive and capacitive loads.

Description

This board provides you an easy way to connect STMicroelectronics® VIPower® technology into your existing system.

Table 1. Device summary

Order code	Reference
EV-VND5T100AJ	VND5T100AJ-E Evaluation board

Contents

1	Overview	5
2	Board connections	6
3	Thermal data	9
4	Revision history	10

List of tables

Table 1.	Device summary	1
Table 2.	J3 connector: pin functions	6
Table 3.	EV-VND5T100AJ thermal data	9
Table 4.	Pcb specifications	9
Table 5.	Document revision history	10

List of figures

Figure 1.	VND5T100AJ-E Evaluation board schematic	5
Figure 2.	Evaluation board connection	6
Figure 3.	No sense resistor	7
Figure 4.	Mounting through-hole sense resistor	8
Figure 5.	Pads for soldering SMD resistor	8

1 Overview

The board comes pre-assembled with VND5T100AJ-E High Side driver. On board minimum set of electrical components (as for device datasheet recommendation) is enabling the user to directly connect the load, the power supply and the microcontroller without any additional effort in external component design and connection. The VND5T100AJ-E is a device made using STMicroelectronics® VIPower® technology, intended for driving resistive or inductive loads with one side connected to ground. Active V_{CC} pin voltage clamp protects the device against low energy spikes. This device integrates an analog current sense which delivers a current proportional to the load current. Fault conditions such as overload, overtemperature or short to V_{CC} are reported via the current sense pin.

Output current limitation protects the device in overload condition. The device latches off in case of overload or thermal shutdown. The device is reset by a low level pass on the fault reset standby pin. A permanent low level on the inputs and fault reset standby pin disables all outputs and sets the device in standby mode.

Figure 1. VND5T100AJ-E Evaluation board schematic

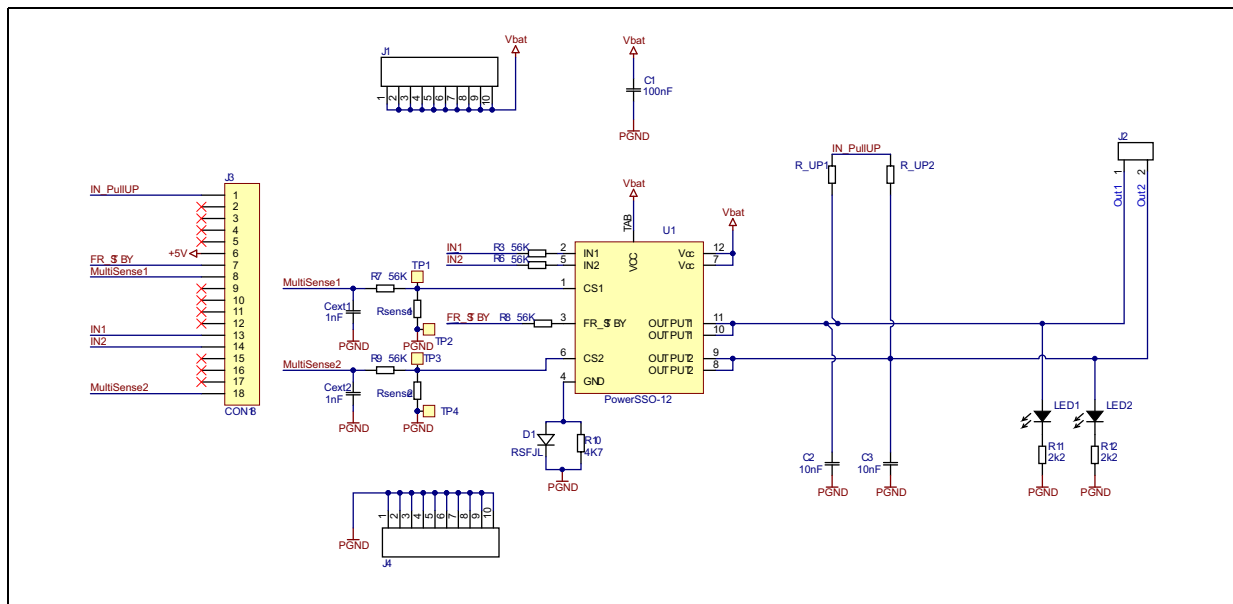

2 Board connections

Below [Figure 2: Evaluation board connection](#) shows the placement of the connectors to be used for supplying the evaluation board, connecting the load and controlling the functionality and diagnostic of the device.

Figure 2. Evaluation board connection

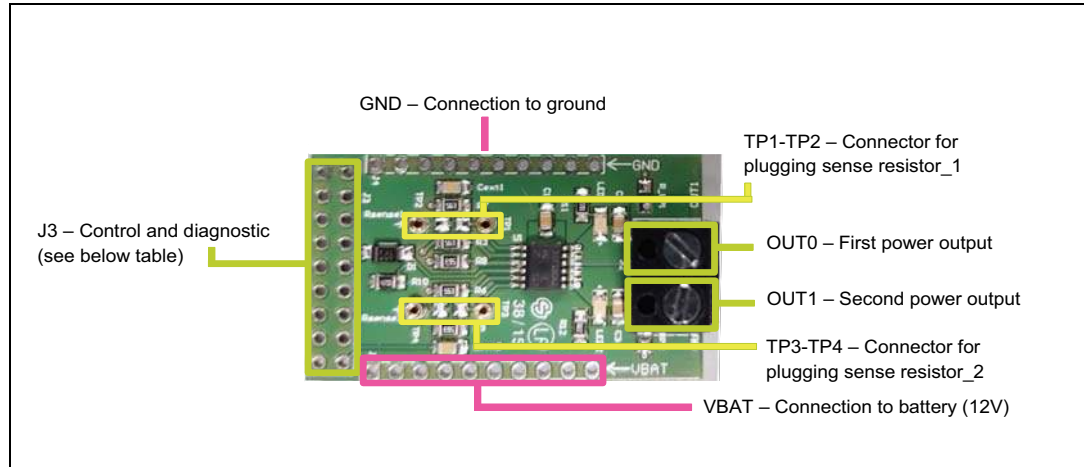

Table 2. J3 connector: pin functions

Connector	Pin number	Pin name	Pin function
J3	1	IN_PullUP	Connection to optional external pull-up resistor for open load detection in off-state.
J3	2...5	N/A	Not connected
J3	6	+5V	5V Power Supply
J3	7	FR_STBY	In case of latch-off for overtemperature/overcurrent condition, a low pulse on the FR_Stby pin is needed to reset the channel. The device enters in standby mode if all inputs and the FR_Stby pin are low
J3	8	MultiSense 1	Analog current sense output pin delivers a current proportional to the load current.
J3	9...12	N/A	Not connected

Table 2. J3 connector: pin functions (continued)

Connector	Pin number	Pin name	Pin function
J3	13	IN0	Voltage controlled input pin with hysteresis, compatible with 3V and 5 V CMOS outputs. It controls OUT0 switch state.
J3	14	IN1	Voltage controlled input pin with hysteresis, compatible with 3V and 5 V CMOS outputs. It controls OUT1 switch state.
J3	15...17	N/A	Not connected
J3	18	Multisense 2	Analog current sense output pin delivers a current proportional to the load current.

In case the user wishes to utilize the Current Sense / MultiSense function of the device, it is necessary to plug a sense resistor in Rsense.

The package includes a through-hole resistor, to be mounted on TP1-TP2 - see [Figure 4: Mounting through-hole sense resistor](#). Different Rsense values can be adopted based on user preference.

Another option is soldering an SMD resistor on the dedicated PCB pad, as shown in [Figure 5: Pads for soldering SMD resistor](#).

Figure 3. No sense resistor



Figure 4. Mounting through-hole sense resistor

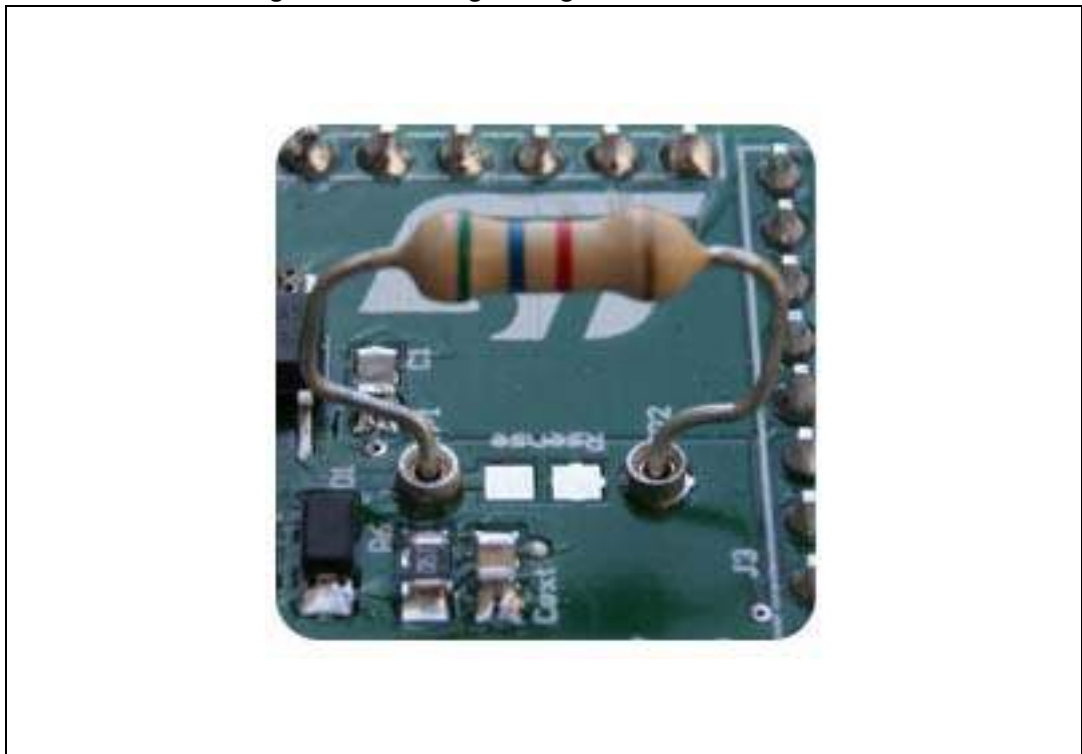

Figure 5. Pads for soldering SMD resistor



3 Thermal data

Table 3. EV-VND5T100AJ thermal data

Symbol	Parameter	Max	Unit
$R_{thj-amb}$	Thermal resistance junction-ambient (Max)	39 °	° C/W

Table 4. Pcb specifications

Parameter	Value
Board dimensions	25 mm x 41.5 mm
Number of CU layer	2
Layer Cu thickness	35 μ m
Board finish thickness	1.6 mm \pm 10 %
Board Material	FR4
Thermal vias separation	1.1 mm
Thermal vias diameter	0.5 mm

4 Revision history

Table 5. Document revision history

Date	Revision	Changes
31-May-2018	1	Initial release.

IMPORTANT NOTICE – PLEASE READ CAREFULLY

STMicroelectronics NV and its subsidiaries ("ST") reserve the right to make changes, corrections, enhancements, modifications, and improvements to ST products and/or to this document at any time without notice. Purchasers should obtain the latest relevant information on ST products before placing orders. ST products are sold pursuant to ST's terms and conditions of sale in place at the time of order acknowledgement.

Purchasers are solely responsible for the choice, selection, and use of ST products and ST assumes no liability for application assistance or the design of Purchasers' products.

No license, express or implied, to any intellectual property right is granted by ST herein.

Resale of ST products with provisions different from the information set forth herein shall void any warranty granted by ST for such product.

ST and the ST logo are trademarks of ST. All other product or service names are the property of their respective owners.

Information in this document supersedes and replaces information previously supplied in any prior versions of this document.

© 2018 STMicroelectronics – All rights reserved