

# "High Frequency Ceramic Solutions"

**900MHz / 2.4GHz SMD Diplexer for IoT, BLE, WiFi, Zigbee, LPWAN, Home Automation, and Smart Readers.**

**P/N 0900DP15A2450**

Detail Specification: 8/26/2016

Page 1 of 3

Not exactly what you are looking for and want to see our other diplexers? Go to: [www.johansontechnology.com/diplexers](http://www.johansontechnology.com/diplexers)

## General Specifications

Passband (MHz)	863 ~ 960	2400 ~ 2500
Insertion Loss (dB)	0.57 typ. 0.65 max.	1.3 typ. 1.4 max.
Return loss (dB)	9.5 min.	
Attenuation (dB)	27.5 typ./25 min. @1726-1920MHz 23 typ./17 min. @2589-2880MHz 14 typ./ 9 min. @3452-3840MHz	22 typ./17 min. @1850-1910MHz 36 typ./20 min. @4800-5000MHz 17 typ./12 min. @7200-7500MHz
Isolation (dB)	33 Typ./30 min. @2400-2500MHz	44 Typ./35 min. @863-960MHz
Operating Temp.	-40 to +85 °C	



Actual product picture

Storage Conditions <sup>1</sup>	-45 to +85°C
Storage Period	18 months max.
Power Capacity	2W max. (CW)
Reel Quantity	4,000 pcs

<sup>1</sup>For pre-installation storage (product still on T&R) +5 to +35 °C, Humidity 45~75%RH is recommended

## Part Number Explanation

P/N Suffix	Packing Style	Bulk	Suffix = S	eg. 0900DP15A2450S
		T & R	Suffix = E	eg. 0900DP15A2450E
	Termination style	100% Tin	Suffix = None	eg. 0900DP15A2450(E or S)
	Evaluation Board	0900DP15A2450-EB1SMA		

## Terminal Configuration

No.	Function
1	2.4G Band
2	GND
3	900M Band
4	GND
5	Common Port
6	GND

(Top)

## Mechanical Dimensions

	In	mm
L	0.079 ± 0.004	2.00 ± 0.1
W	0.049 ± 0.004	1.25 ± 0.1
T	0.037 ± 0.004	0.95 ± 0.1
a	0.012 ± 0.004	0.30 ± 0.1
b	0.008 ± 0.004	0.20 ± 0.1
c	0.012 +0.004/-0.008	0.30 +0.1/-0.2
g	0.014 ± 0.004	0.35 ± 0.10
p	0.026 ± 0.002	0.65 ± 0.05

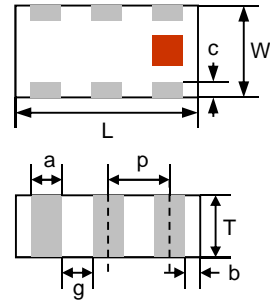

## Mounting Considerations

Need the layout file of the above? Send us a message at: [www.johansontechnology.com/ask-a-question](http://www.johansontechnology.com/ask-a-question)

- Solder Resist
- Land
- Through-hole (φ0.35)

\* Line width should be designed to match 50Ω characteristic impedance, depending on PCB material and thickness. CPWG designed recommended.

## Measuring Diagram

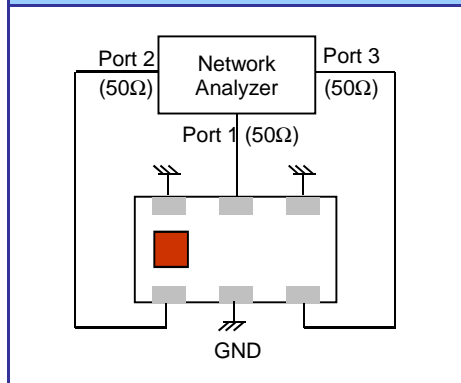

# "High Frequency Ceramic Solutions"

900MHz / 2.4GHz SMD Diplexer for IoT, BLE, WiFi, Zigbee,  
LPWAN, Home Automation, and Smart Readers.

P/N 0900DP15A2450

Detail Specification: 8/26/2016

Page 2 of 3

## Typical Electrical Characteristics (T=25 °C)

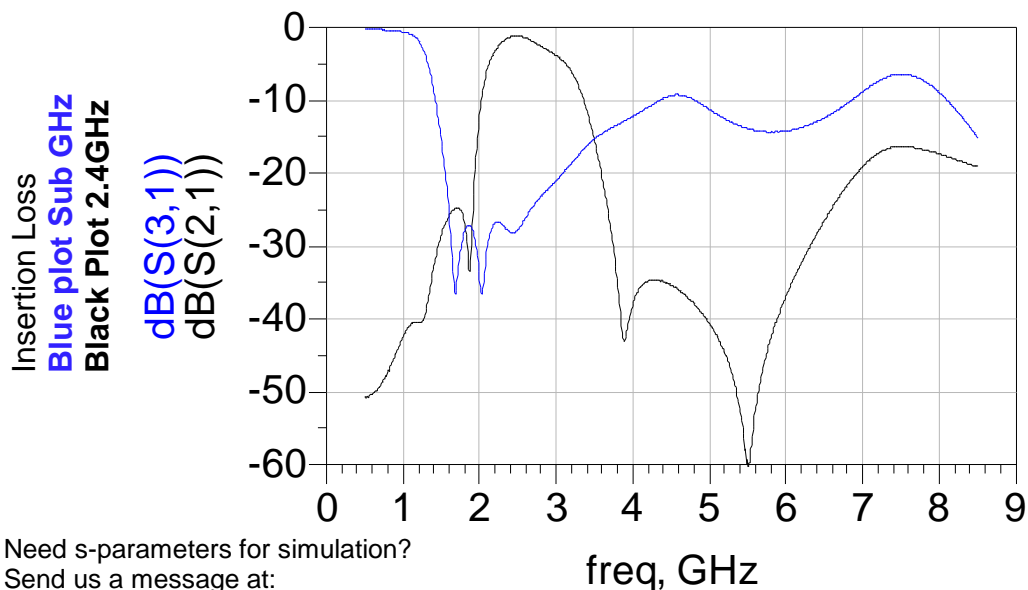

Need s-parameters for simulation?

Send us a message at:

[www.johansontechnology.com/ask-a-question](http://www.johansontechnology.com/ask-a-question)

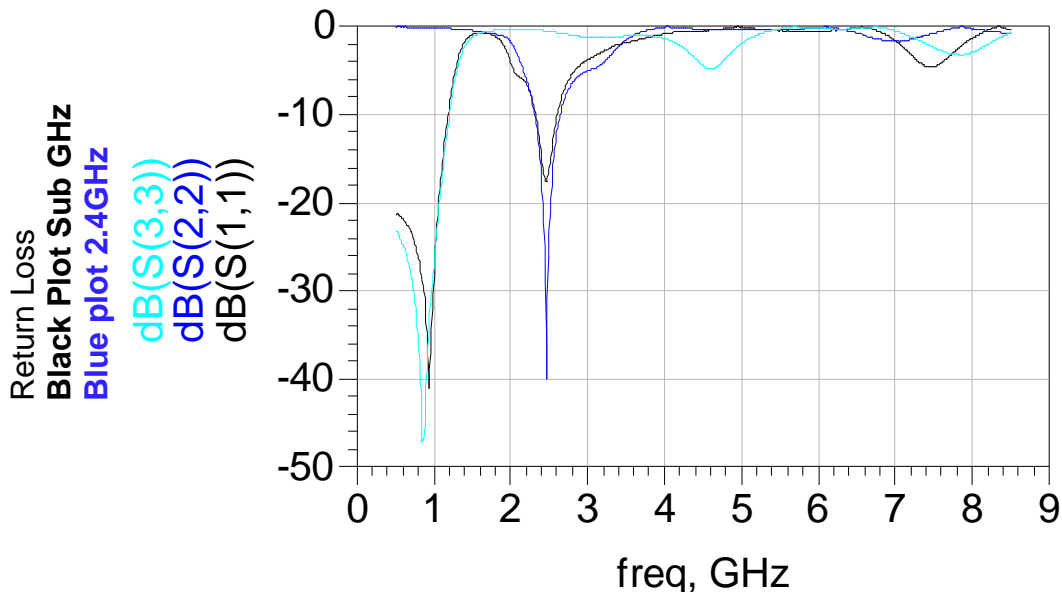

The contents of this data sheet are subject to change without notice. Please confirm the specifications and delivery conditions when placing your order. All sales are subject to Johanson Technology, Inc. terms and conditions.

# "High Frequency Ceramic Solutions"

900MHz / 2.4GHz SMD Diplexer for IoT, BLE, WiFi, Zigbee,  
LPWAN, Home Automation, and Smart Readers.

P/N 0900DP15A2450

Detail Specification: 8/26/2016

Page 3 of 3

## RoHS Compliance

<http://www.johansontechnology.com/rohs-compliance>

## Packaging information

<http://www.johansontechnology.com/tape-reel-packaging>

## Soldering Information

[www.johansontechnology.com/ipcsoldering-profile](http://www.johansontechnology.com/ipcsoldering-profile)

## Layout Files, s-parameters and any other technical questions

<http://www.johansontechnology.com/ask-a-question>

## MSL Info

<http://www.johansontechnology.com/msl-rating>

## Recommended Storage Condition and Max Shelf Life

<http://www.johansontechnology.com/recommended-storage-conditions>

## Antenna layout and tuning techniques

[www.johansontechnology.com/tuning](http://www.johansontechnology.com/tuning)

## Antenna layout review, tuning, and characterization services

<http://www.johansontechnology.com/ipc-antenna-services>

Need some FREE design guidance, layout/gerber files, or s-parameters for simulation?  
Send us a message at:  
[www.johansontechnology.com/ask-a-question](http://www.johansontechnology.com/ask-a-question)

The contents of this data sheet are subject to change without notice. Please confirm the specifications and delivery conditions when placing your order. All sales are subject to Johanson Technology, Inc. terms and conditions.

